

# EKKO<sup>®</sup>

**MATERIAL HANDLING EQUIPMENT**

**MOVING  
AHEAD**

# CATALOG



[www.ekkolifts.com](http://www.ekkolifts.com)

# Table of Contents

About US	3
<b>FORKLIFTS</b>	
LPG Forklift	4-12
Rough Terrain Forklift	13-14
Deisel Forklift	15-19
Electric 4 Wheel Forklift	20-34
Electric Stand-up Rider Forklift	35-37
Electric 3 Wheel Forklift	38-42
<b>REACH TRUCKS</b>	
Electric Reach Trucks	43-51
<b>COUNTERBALANCED STACKERS</b>	
Electric Counterbalanced Stackers	52-59
<b>ORDER PICKERS</b>	
Electric Order Pickers	60-62
<b>STRADDLE STACKERS</b>	
Electric Walkie Straddle Stackers	63-80
<b>PALLET JACKS</b>	
Electric and Manual Pallet Jacks	81-97
<b>SCISSOR LIFT TABLE AERIAL PLATFORM</b>	
Scissor Lift Aerial Platform	98-107
<b>SCISSOR LIFT TABLE CART</b>	
Scissor Lift Table Cart	108
<b>TOW TRACTORS</b>	
Tow Tractor	109

## About Us

Since 2008, EKKO Material Handling Equipment Manufacturing Inc. Has become the go to manufacturer for the OEM AND ODM channel. Due to our experience, innovative manufacturing capabilities, design and our collaborations internationally, we have created enormous success with our partners in supplying them with nothing but quality forklifts, pallet trucks, walkie pallet trucks, rider pallet trucks, stackers, walkie stackers, order pickers, reach trucks, counterbalance walkie stackers, aerial scissor lift work platforms.

With our strict research and development, quality control, and quality assurance departments, every product has and will continue to pass CE certification with international safety standards and ISO9001 Certification. In addition, our products have acquired self-managed import and export rights throughout North and South America, Europe, Australia and Asia.

OEM and ODM channels are welcomed. Furthermore, non-standard equipment is capable for production according to the customer's specifications within reason. EKKO insists on the operating theory of "Services Create Enterprise Value", offering you top-ranking quality and professional after-service.

EKKO units are a great choice for dependable, efficient, cost-effective and the fastest lead times on the market. Below please find our product line of LPG Forklifts, Electric Forklifts, Counterbalance Stackers, Straddle Stackers, Pallet Jacks, Scissor Lifts, Tow Tractors.



## EK25LP Liquid Propane Forklift

Model		EK25LP
Lift		Propane
Drive		Sit-Down
Load capacity	(lb.)	5000
Load center distance	(in)	24
Tire	(in)	Solid Pneumatic
Lifting height	(in)	189
Free lifting height	(in)	47.64"
Lowered mast height	(in)	87
Mast tilting angle (front / rear)	( ° )	6/12
Service Brake		Hydraulic Floor Pedal
Overall length	(in)	143.9
Overall width	(in)	45.3
Fork size, Thick/Width/Length	(in)	42.1X4.8X1.57
Wheelbase	(in)	65
Min turning radius (exterior)	(in)	88.2
Driving speed, load/unload	Mph	11.2/11.8
Engine Mode		Kubota WG2503
Engine rated power	HP/rpm	LPG: 58.3/2600
Engine rated torque	Ft*lb./rpm	LPG: 120.7*1800
Engine cylinder number-bore X stroke	(In)	4-3.5x40.3
Service Weight	(lb.)	8,910

The EKKO EK25LP Liquid Propane 4 Wheel Forklift is designed to be used for all your material handling demands, warehousing, and distribution.

This unit is manufactured with high durable quality, Tier 4 EPA compliant with the Kubota engine and competitive pricing.

- Multifunction instrument panel - motoring for Safety and efficient operation
- Operator compartment- nonslip entrance step, wider access & leg room.
- Adjustable steering column limiting operator arm and shoulder fatigue.
- Excellent Operator visibility.
- Integral Heavy-Duty Chassis- ensuring driver protection
- Steer axle pivots to 80 degrees for tighter turning radius.
- Hydraulic controls
- 3 Year Limited Warranty

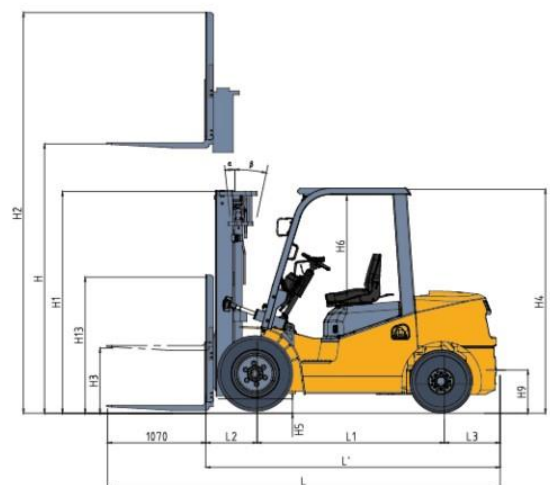
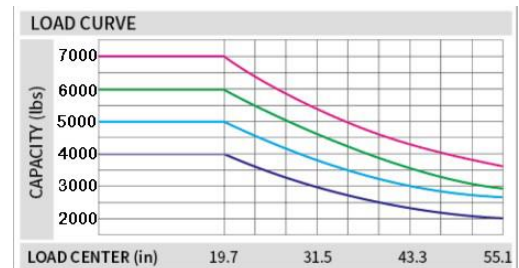

## EK25-212LP Liquid Propane Forklift

Model		EK25-212LP
Lift		Propane
Drive		Sit-Down
Load capacity	(lb.)	5000
Load center distance	(in)	24
Tire	(in)	Solid Pneumatic
Lifting height	(in)	212
Free lifting height	(in)	55.1
Lowered mast height	(in)	94.5
Mast tilting angle (front / rear)	( ° )	6/12
Service Brake		Hydraulic Floor Pedal
Overall length	(in)	143.9
Overall width	(in)	45.3
Fork size, Thick/Width/Length	(in)	42.1X4.8X1.57
Wheelbase	(in)	65
Min turning radius (exterior)	(in)	88.2
Driving speed, load/unload	Mph	11.2/11.8
Engine Mode		Kubota WG2503
Engine rated power	HP/rpm	LPG: 58.3/2600
Engine rated torque	Ft*lb./rpm	LPG: 120.7*1800
Engine cylinder number-bore X stroke	In	4-3.5x40.3
Service Weight	(lb.)	9,020

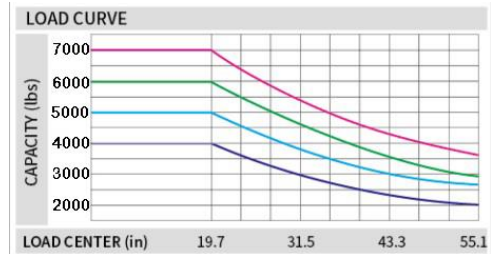
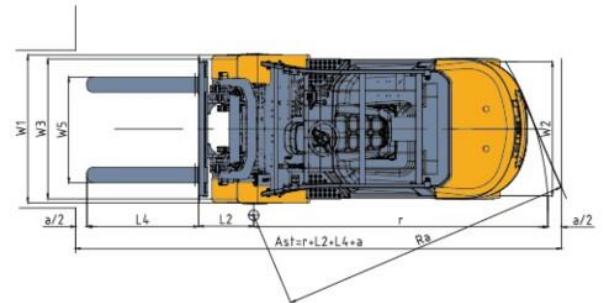
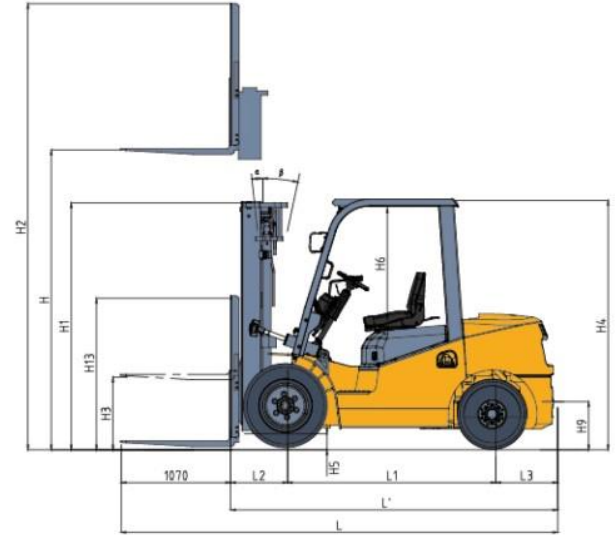

The EKKO EK25-212LP Liquid Propane 4 Wheel Forklift is designed to be used for all your material handling demands, warehousing, and distribution.

This unit is manufactured with high durable quality, Tier 4 EPA compliant with the Kubota engine and competitive pricing.

- Multifunction instrument panel - motoring for Safety and efficient operation
- Operator compartment- nonslip entrance step, wider access & leg room.
- Adjustable steering column limiting operator arm and shoulder fatigue.
- Excellent Operator visibility.
- Integral Heavy-Duty Chassis- ensuring driver protection
- Steer axle pivots to 80 degrees for tighter turning radius.
- Hydraulic controls
- 3 Year Limited Warranty



## EK25CLP Liquid Propane Forklift

Model		EK25CLP
Lift		Propane
Drive		Sit-Down
Load capacity	(lb.)	5000
Load center distance	(in)	24
Tire	(in)	Smooth Cushion Tire
Lifting height	(in)	189
Free lifting height	(in)	44
Lowered mast height	(in)	85
Mast tilting angle (front / rear)	( ° )	6/12
Service Brake		Hydraulic Floor Pedal
Overall length	(in)	136.8
Overall width	(in)	42
Fork size, Thick/Width/Length	(in)	42X4.8X1.57
Wheelbase	(in)	58
Min turning radius (exterior)	(in)	88.2
Driving speed, load/unload	Mph	10.8/10.8
Engine Mode		Mitsubishi 4g64 (PSI engine)
Engine rated power	HP/rpm	LPG: 63/2700
Service Weight	(lb.)	9,590

The EKKO EK25CLP Liquid Propane 4 Wheel Forklift is designed to be used for all your material handling demands, warehousing, and distribution. This unit is manufactured with high durable quality, Tier 4 EPA compliant with the PSI engine and competitive pricing.

- The operation space is enlarged by heightened overhead guard and using large arc shape of the overhead guard's front leg.
- Semi-suspension seat, and small steering wheel, electro-hydraulic direction changing, and automobile type double combined switch effectively improve driving comfort level.
- Cushion connection and whole suspension cab can absorb the vibrations of truck effectively.
- Lowering damping device inside the lifting system reduces mast's shock and vibration, avoiding noise caused by goods falling to the ground.
- Small turning radius makes steering flexible and easy.
- with optimized hydraulic system, the truck is more energy-efficient and has lower fuel consumption.
- The engine satisfies the CARB 4 regulation.



Features Smooth Cushion Tires that are perfect for use indoors on a smooth flat surface.

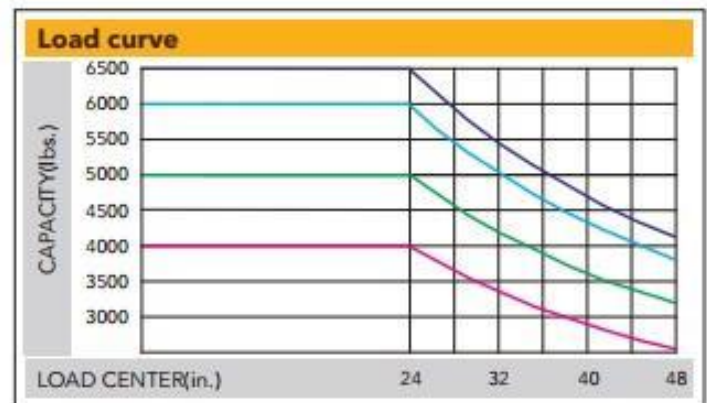

## EK25SLP Liquid Propane Forklift

Model		EK25SLP
Lift		Propane
Drive		Sit-Down
Load capacity	(lb.)	5000
Load center distance	(in)	24
Tire	(in)	Pattern Cushion Tire
Lifting height	(in)	189
Free lifting height	(in)	44
Lowered mast height	(in)	85
Mast tilting angle (front / rear)	( ° )	6/12
Service Brake		Hydraulic Floor Pedal
Overall length	(in)	136.8
Overall width	(in)	42
Fork size, Thick/Width/Length	(in)	42X4.8X1.57
Wheelbase	(in)	58
Min turning radius (exterior)	(in)	88.2
Driving speed, load/unload	Mph	10.8/10.8
Engine Mode		Mitsubishi 4g64 (PSI engine)
Engine rated power	HP/rpm	LPG: 63/2700
Service Weight	(lb.)	9,495

The EKKO EK25SLP Liquid Propane 4 Wheel Forklift is designed to be used for all your material handling demands, warehousing, and distribution. This unit is manufactured with high durable quality, Tier 4 EPA compliant with the PSI engine and competitive pricing.

- The operation space is enlarged by heightened overhead guard and using large arc shape of the overhead guard's front leg.
- Semi-suspension seat, and small steering wheel, electro-hydraulic direction changing, and automobile type double combined switch effectively improve driving comfort level.
- Cushion connection and whole suspension cab can absorb the vibrations of truck effectively.
- Lowering damping device inside the lifting system reduces mast's shock and vibration, avoiding noise caused by goods falling to the ground.
- Small turning radius makes steering flexible and easy.
- with optimized hydraulic system, the truck is more energy-efficient and has lower fuel consumption.
- The engine satisfies the CARB 4 regulation.



Features Pattern Cushion Tires that are perfect for use indoors OR outdoors

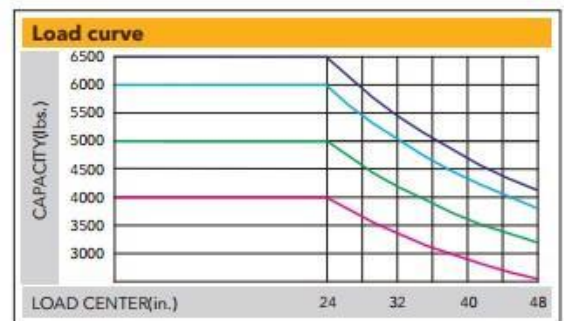

## EK30LP Liquid Propane Forklift

Model		EK30LP
Lift		Propane
Drive		Sit-Down
Load capacity	(lb.)	6000
Load center distance	(in)	24
Tire	(in)	Solid Pneumatic
Lifting height	(in)	189
Free lifting height	(in)	40.9
Lowered mast height	(in)	89.4
Mast tilting angle (front / rear)	( ° )	6/12
Service Brake		Hydraulic Floor Pedal
Overall length	(in)	150.3
Overall width	(in)	48.2
Fork size, Thick/Width/Length	(in)	42.1X4.9X1.77
Wheelbase	(in)	69
Min turning radius (exterior)	(in)	94.5
Driving speed, load/unload	Mph	11.8/11.8
Engine Mode		Kubota WG2503
Engine rated power	HP/rpm	LPG: 58.3/2600
Service Weight	(lb.)	10,320

The EKKO EK30LP Liquid Propane 4 Wheel Forklift is designed to be used for all your material handling demands, warehousing, and distribution.

This unit is manufactured with high durable quality, Tier 4 EPA compliant with the Kubota engine and competitive pricing.

- Multifunction instrument panel - motoring for Safety and efficient operation
- Operator compartment- nonslip entrance step, wider access & leg room.
- Adjustable steering column limiting operator arm and shoulder fatigue.
- Excellent Operator visibility.
- Integral Heavy-Duty Chassis- ensuring driver protection
- Steer axle pivots to 80 degrees for tighter turning radius.
- Hydraulic controls

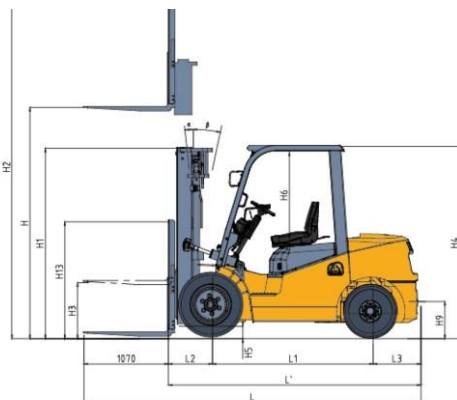
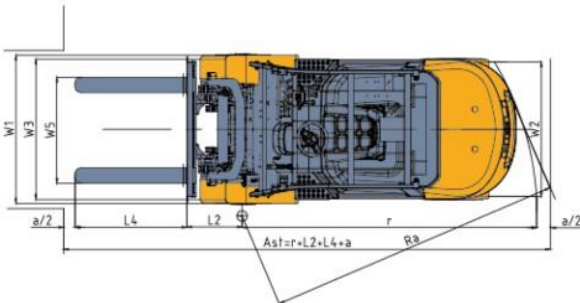



## EK30SLP Liquid Propane Forklift

Model		EK30SLP
Lift		Propane
Drive		Sit-Down
Load capacity	(lb.)	6000
Load center distance	(in)	24
Tire	(in)	Solid Pneumatic
Lifting height	(in)	189
Free lifting height	(in)	40.9
Lowered mast height	(in)	89.4
Mast tilting angle (front / rear)	( ° )	6/12
Service Brake		Hydraulic Floor Pedal
Overall length	(in)	150.3
Overall width	(in)	48.2
Fork size, Thick/Width/Length	(in)	42.1X4.9X1.77
Wheelbase	(in)	69
Min turning radius (exterior)	(in)	94.5
Driving speed, load/unload	Mph	11.8/11.8
Engine Mode		Kubota WG2503
Engine rated power	HP/rpm	LPG: 58.3/2600
Service Weight	(lb.)	10,320

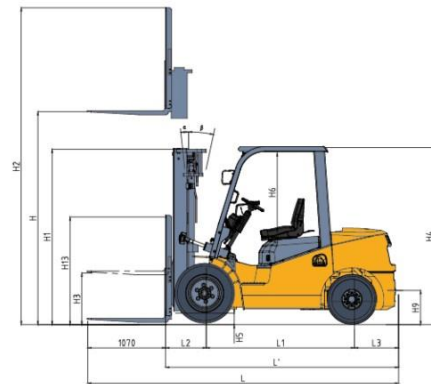
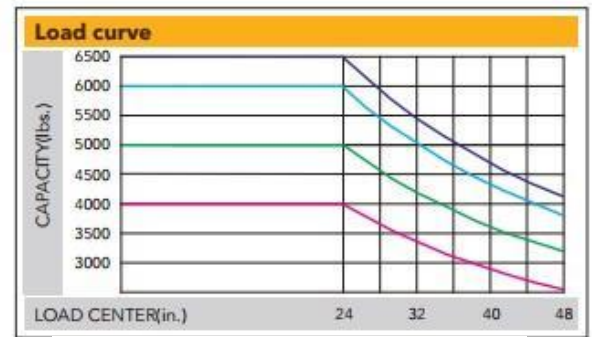

Features Pattern Cushion Tires that are perfect for use indoors OR outdoors

The EKKO EK30SLP Liquid Propane 4 Wheel Forklift is designed to be used for all your material handling demands, warehousing, and distribution.

This unit is manufactured with high durable quality, Tier 4 EPA compliant with the PSI engine and competitive pricing.

- The operation space is enlarged by heightened overhead guard and using large arc shape of the overhead guard's front leg.
- Semi-suspension seat, and small steering wheel, electro-hydraulic direction changing, and automobile type double combined switch effectively improve driving comfort level.
- Cushion connection and whole suspension cab can absorb the vibrations of truck effectively.
- Lowering damping device inside the lifting system reduces mast's shock and vibration, avoiding noise caused by goods falling to the ground.
- Small turning radius makes steering flexible and easy.
- with optimized hydraulic system, the truck is more energy-efficient and has lower fuel consumption.
- The engine satisfies the CARB 4 regulation.



## EK35LP Liquid Propane Forklift

Model		EK35LP
Lift		Propane
Drive		Sit-Down
Load capacity	(lb.)	7000
Load center distance	(in)	24
Tire	(in)	Solid Pneumatic
Lifting height	(in)	189
Free lifting height	(in)	42.9
Lowered mast height	(in)	89.4
Mast tilting angle (front / rear)	( ° )	6/12
Service Brake		Hydraulic Floor Pedal
Overall length	(in)	150.4
Overall width	(in)	48.2
Fork size, Thick/Width/Length	(in)	42.1X4.9X1.77
Wheelbase	(in)	68.9
Min turning radius (exterior)	(in)	94.5
Driving speed	Mph	11.87
Engine Mode		Kubota WG2503
Engine rated power	HP/rpm	LPG: 58.3/2600
Service Weight	(lb.)	10,605

The EKKO EK35LP Liquid Propane 4 Wheel Forklift is designed to be used for all your material handling demands, warehousing, and distribution.

This unit is manufactured with high durable quality, Tier 4 EPA compliant with the Kubota engine and competitive pricing.

- Multifunction instrument panel - motoring for Safety and efficient operation
- Operator compartment- nonslip entrance step, wider access & leg room.
- Adjustable steering column limiting operator arm and shoulder fatigue.
- Excellent Operator visibility.
- Integral Heavy-Duty Chassis- ensuring driver protection
- Steer axle pivots to 80 degrees for tighter turning radius.
- Hydraulic controls

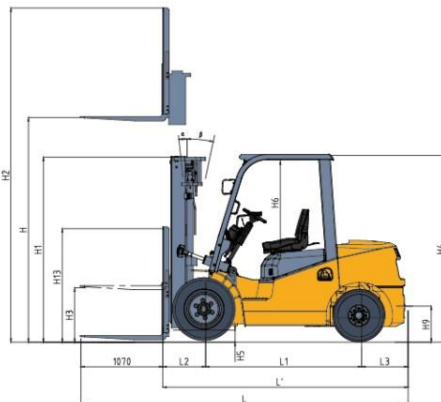
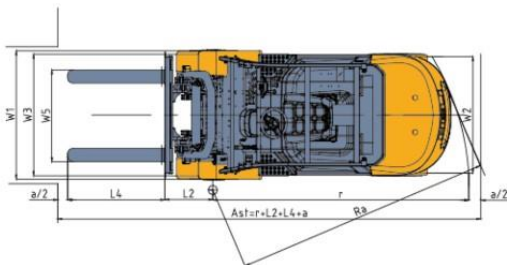
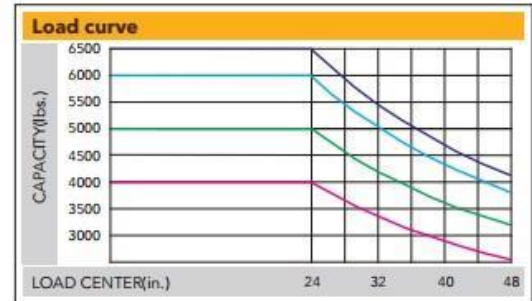

## EK50LP Liquid Propane Forklift

Model		EK50LP
Lift		Propane
Drive		Sit-Down
Load capacity	(lb.)	10,000
Load center distance	(in)	24
Tire	(in)	Pattern Cushion Tire
Lifting height	(in)	185
Free lifting height	(in)	44.3
Lowered mast height	(in)	91.9
Mast tilting angle (front / rear)	( ° )	6/12
Service Brake		Hydraulic Floor Pedal
Overall length	(in)	157
Overall width	(in)	55.9
Fork size, Thick/Width/Length	(in)	48x5.9x1.97
Wheelbase	(in)	61.8
Min ground clearance	(in)	4.3
Driving speed laden/unladen	Mph	10.5/11.2
Engine Mode		Kubota WG3800
Engine rated power	HP/rpm	63.2
Service Weight	(lb.)	16,250

The EKKO EK50LP Liquid Propane 4 Wheel Forklift is designed to be used for all your material handling demands, warehousing, and distribution.

This unit is manufactured with high durable quality, Tier 4 EPA compliant with the Kubota engine and competitive pricing.

- Multifunction instrument panel - motoring for Safety and efficient operation
- Operator compartment- nonslip entrance step, wider access & leg room.
- Adjustable steering column limiting operator arm and shoulder fatigue.
- Excellent Operator visibility.
- Integral Heavy-Duty Chassis- ensuring driver protection
- Steer axle pivots to 80 degrees for tighter turning radius.
- Hydraulic controls

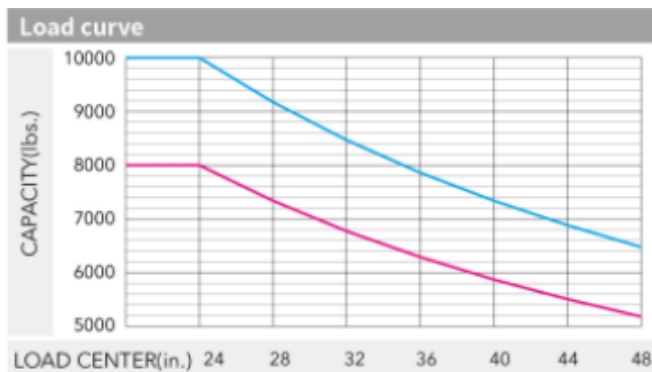

## EK70LP Liquid Propane Forklift

**COMING SOON**

Model		EK70LP
Lift		Propane
Drive		Sit-Down
Load capacity	(lb.)	15,500
Load center distance	(in)	24
Tire	(in)	Solid Pneumatic Tire
Lifting height	(in)	189
Free lifting height	(in)	
Lowered mast height	(in)	
Mast tilting angle (front / rear)	( ° )	6/12
Service Brake		Hydraulic Floor Pedal
Overall length	(in)	
Overall width	(in)	
Fork size, Thick/Width/Length	(in)	48x5.9x1.97
Wheelbase	(in)	
Min ground clearance	(in)	
Driving speed laden/unladen	Mph	
Engine Mode		Kubota WG3800
Engine rated power	HP/rpm	
Service Weight	(lb.)	22,569

More  
information  
coming soon!!



## EK30LP-RT Rough Terrain Propane Forklift

Model		EK30LP-RT
Lift		Propane
Drive		Sit-Down
Load capacity	(lb.)	6,000
Load center distance	(in)	24
Tire	(in)	Solid Pneumatic Tire
Lifting height	(in)	185
Free lifting height	(in)	
Lowered mast height	(in)	
Mast tilting angle (front / rear)	( ° )	6/12
Service Brake		Hydraulic Floor Pedal
Overall length	(in)	
Overall width	(in)	
Fork size	(in)	42
Wheelbase	(in)	
Min ground clearance	(in)	
Driving speed laden/unladen	Mph	
Engine Mode		Kubota V2607
Engine rated power	HP/rpm	
Service Weight	(lb.)	12,100

More information coming soon!!



## EK35LP-RT Rough Terrain Propane Forklift

Model		EK35LP-RT
Lift		Propane
Drive		Sit-Down
Load capacity	(lb.)	7,000
Load center distance	(in)	24
Tire	(in)	Solid Pneumatic Tire
Lifting height	(in)	185
Free lifting height	(in)	
Lowered mast height	(in)	
Mast tilting angle (front / rear)	( ° )	6/12
Service Brake		Hydraulic Floor Pedal
Overall length	(in)	
Overall width	(in)	
Fork size	(in)	42
Wheelbase	(in)	
Min ground clearance	(in)	
Driving speed laden/unladen	Mph	
Engine Mode		Kubota V2607
Engine rated power	HP/rpm	
Service Weight	(lb.)	12,950

More  
information  
coming soon!!



## EK30D Diesel Forklift

Model		EK30D
Lift		Diesel
Drive		Sit-Down
Load capacity	(lb.)	6,000
Load center distance	(in)	24
Tire	(in)	Solid Pneumatic Tire
Lifting height	(in)	189
Free lifting height	(in)	
Lowered mast height	(in)	
Mast tilting angle (front / rear)	( ° )	6/12
Service Brake		Hydraulic Floor Pedal
Overall length	(in)	
Overall width	(in)	
Fork size	(in)	42
Wheelbase	(in)	
Min ground clearance	(in)	
Driving speed laden/unladen	Mph	
Engine Mode		Kubota V2403
Engine rated power	HP/rpm	
Service Weight	(lb.)	9,850

More information coming soon!!

**COMING SOON**

## EK35D Diesel Forklift

Model		EK35D
Lift		Diesel
Drive		Sit-Down
Load capacity	(lb.)	7,000
Load center distance	(in)	24
Tire	(in)	Solid Pneumatic Tire
Lifting height	(in)	189
Free lifting height	(in)	
Lowered mast height	(in)	
Mast tilting angle (front / rear)	( ° )	6/12
Service Brake		Hydraulic Floor Pedal
Overall length	(in)	
Overall width	(in)	
Fork size	(in)	42
Wheelbase	(in)	
Min ground clearance	(in)	
Driving speed laden/unladen	Mph	
Engine Mode		Kubota V2403
Engine rated power	HP/rpm	
Service Weight	(lb.)	12,000

More  
information  
coming soon!!

**COMING  
SOON**



## EK50D Diesel Forklift

Model		EK50D
Lift		Diesel
Drive		Sit-Down
Load capacity	(lb.)	10,000
Load center distance	(in)	24
Tire	(in)	Solid Pneumatic Tire
Lifting height	(in)	185
Free lifting height	(in)	
Lowered mast height	(in)	
Mast tilting angle (front / rear)	( ° )	6/12
Service Brake		Hydraulic Floor Pedal
Overall length	(in)	
Overall width	(in)	
Fork size	(in)	42
Wheelbase	(in)	
Min ground clearance	(in)	
Driving speed laden/unladen	Mph	
Engine Mode		Cummins QSF 3.8 (tier VI)
Engine rated power	HP/rpm	
Service Weight	(lb.)	16,000

More information coming soon!!

**COMING SOON**

## EK100D Diesel Forklift

Model		EK100D
Lift		Diesel
Drive		Sit-Down
Load capacity	(lb.)	22,000
Load center distance	(in)	24
Tire	(in)	Solid Pneumatic Tire
Lifting height	(in)	189
Free lifting height	(in)	
Lowered mast height	(in)	
Mast tilting angle (front / rear)	( ° )	6/12
Service Brake		Hydraulic Floor Pedal
Overall length	(in)	
Overall width	(in)	
Fork size	(in)	48
Wheelbase	(in)	
Min ground clearance	(in)	
Driving speed laden/unladen	Mph	
Engine Mode		Cummins QSF 3.8 (tier VI)
Engine rated power	HP/rpm	
Service Weight	(lb.)	29,500

More  
information  
coming soon!!

**COMING  
SOON**

## EK160D Diesel Forklift

Model		EK160D
Lift		Diesel
Drive		Sit-Down
Load capacity	(lb.)	35,000
Load center distance	(in)	24
Tire	(in)	Solid Pneumatic Tire
Lifting height	(in)	177
Free lifting height	(in)	
Lowered mast height	(in)	
Mast tilting angle (front / rear)	( ° )	6/12
Service Brake		Hydraulic Floor Pedal
Overall length	(in)	
Overall width	(in)	
Fork size	(in)	96
Wheelbase	(in)	
Min ground clearance	(in)	
Driving speed laden/unladen	Mph	
Engine Mode		DIESEL Cummins (Tier IV)
Engine rated power	HP/rpm	
Service Weight	(lb.)	41,500

More  
information  
coming soon!!

**COMING  
SOON**

## EK18GS 4 Wheel Electric Forklift

Model		EK18GS
Lift		Electric
Drive		Sit-Down
Load capacity	(lb.)	4000
Load center distance	(in)	20
Wheelbase	(in)	65.4
Lifting height	(in)	189
Free lifting height	(in)	47.78
Lowered mast height	(in)	79
Mast/Fork carriage tilt forward/backward	( ° )	6/6
Side Shift		3-way valve
Overall length	(in)	133
Overall width	(in)	46.45
Fork size,	(in)	42
Fork adjust width	(in)	
Turning radius	(in)	85
Traveling Speed (laden/unladen)	(mph)	9/9.3
Lift speed, laden/unladen	(in/s)	
ZAPI Controller		ZAPI
Charger	(V/A)	480V 3 phase (220 optional)
Battery voltage	(V/Ah)	48V/480AH LEAD ACID
Service Weight	(lb.)	9,420

The EKKO EK18GS 4 Wheel Electric Forklift is designed for use for all your material handling demands. It is ideal for loading and unloading trucks, loading docks, stock rooms, manufacturing floors and warehousing.

Made from high quality steel and components with durable quality drives to withstand any terrain, usage, impact and directional changes for the use of any application with confidence and assurance.

- Load Capacity 4000 lb.
- Raised Height 189" (15.75ft)
- Side Shifting Forks
- Free Lift 47.48"
- Fork Length 42"
- ZAPI Controller
- Battery 48/600 AH Lead acid
- Solid Pneumatic Tires
- Ergonomic Handle and Controls
- Steel Construction
- Robotic Welding
- 3-Phase 480V Charger (optional 220V)
- 3 Year Limited Warranty

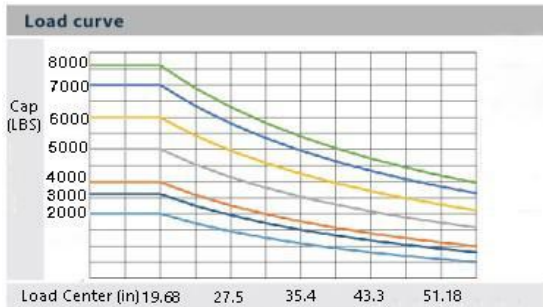
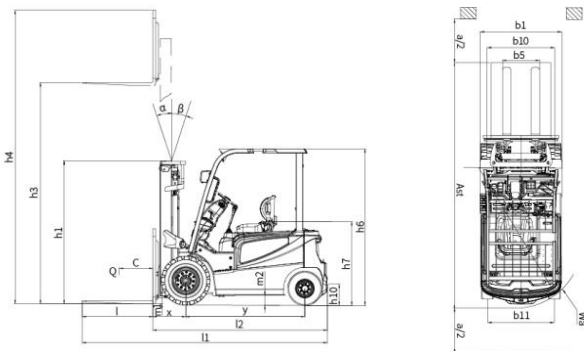

## EK18GSH 4 Wheel Electric Forklift

Model		EK18GSH
Lift		Electric
Drive		Sit-Down
Load capacity	(lb.)	4000
Load center distance	(in)	20
Wheelbase	(in)	65.4
Lifting height	(in)	212
Free lifting height	(in)	47.78
Lowered mast height	(in)	79
Mast/Fork carriage tilt forward/backward	( ° )	6/6
Side Shift		3-way valve
Overall length	(in)	133
Overall width	(in)	46.45
Fork size,	(in)	42
Fork adjust width	(in)	
Turning radius	(in)	85
Traveling Speed (laden/unladen)	(mph)	9/9.3
ZAPI Controller		ZAPI
Charger	(V/A)	480V 3 phase (220 optional)
Battery voltage	(V/Ah)	48V/480AH LEAD ACID
Service Weight	(lb.)	9520
Lift		Electric
Drive		Sit-Down

The EKKO EK18GS 4 Wheel Electric Forklift is designed for use for all your material handling demands. It is ideal for loading and unloading trucks, loading docks, stock rooms, manufacturing floors and warehousing.

Made from high quality steel and components with durable quality drives to withstand any terrain, usage, impact and directional changes for the use of any application with confidence and assurance.

- Load Capacity 5000 lb.
- Raised Height 212"
- Side Shifting Forks
- Free Lift 47.48"
- Fork Length 42"
- ZAPI Controller
- Battery 48/480 AH Lead acid
- Solid Pneumatic Tires
- Ergonomic Handle and Controls
- Steel Construction
- Robotic Welding
- 3-Phase 480V Charger (optional 220V)
- 3 Year Limited Warranty

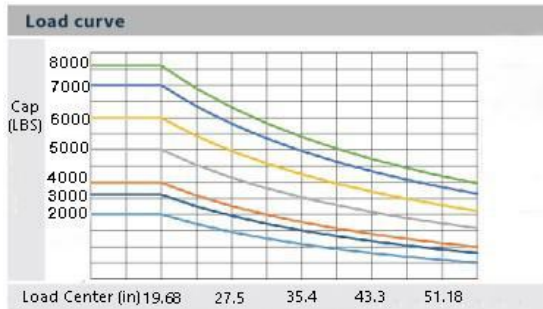
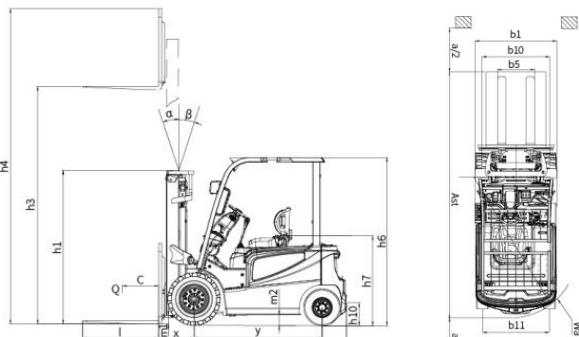

## EK20GS 4 Wheel Electric Forklift

Model		EK20GS
Lift		Electric
Drive		Sit-Down
Load capacity	(lb.)	4500
Load center distance	(in)	20
Wheelbase	(in)	65.4
Lifting height	(in)	189
Free lifting height	(in)	47.48
Lowered mast height	(in)	79
Mast/Fork carriage tilt forward/backward	( ° )	6/6
Side Shift		3-way valve
Overall length	(in)	133
Overall width	(in)	46.45
Fork size,	(in)	42
Min Outside Turning radius	(in)	85
Service Brake		Hydraulic foot pedal
Tires		Solid Pneumatic Tire
ZAPI Controller		ZAPI
Charger	(V/A)	Standard 480v 3phase Optional 220V
Battery voltage	(V/Ah)	48V/600AH LEAD ACID
Service Weight	(lb.)	9,620

The EKKO EK20GS 4 Wheel Electric Forklift is designed for use for all of your material handling demands. It is ideal for loading and unloading trucks, loading docks, stock rooms, manufacturing floors and warehousing.

Made from high quality steel and components with durable quality drives to withstand any terrain, usage, impact and directional changes for the use of any application with confidence and assurance.

- Load Capacity 4500 lb.
- Raised Height 189" (15.75ft)
- Side Shifting Forks
- Free Lift 47.48"
- Fork Length 42"
- ZAPI Controller
- Battery 48/600 AH Lead acid
- Solid Pneumatic Tires
- Ergonomic Handle and Controls
- Steel Construction
- Robotic Welding
- 3-Phase 480V Charger (optional 220V)
- 3 Year Limited Warranty

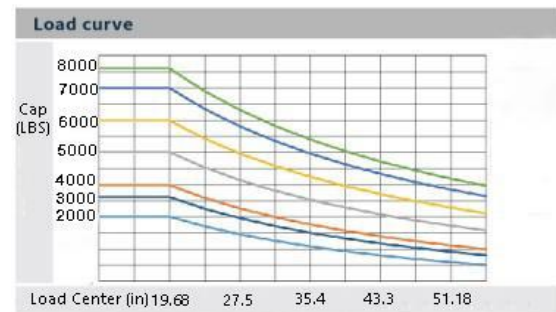
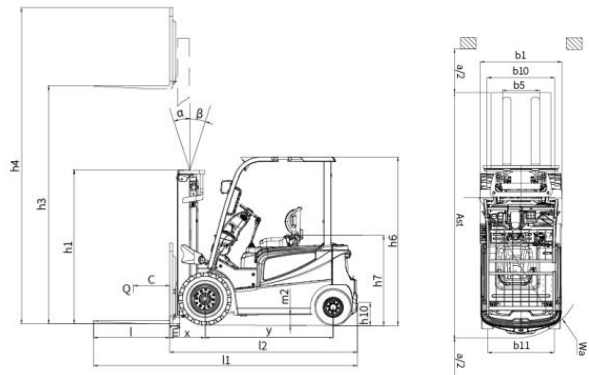

## EK25GB 4 Wheel Electric Forklift

Model		EK25GB
Lift		Electric
Drive		Sit-Down
Load capacity	(lb.)	5000
Load center distance	(in)	20
Wheelbase	(in)	65.35
Lifting height	(in)	189
Free lifting height	(in)	47.48
Lowered mast height	(in)	83
Mast/Fork carriage tilt forward/backward	( ° )	6/6
Side Shift		3-way valve
Overall length	(in)	137.95
Overall width	(in)	46.45
Fork size,	(in)	42
Turning radius	(in)	84.2
Max gradient performance, laden/unladen	(%)	15/25
ZAPI Controller		ZAPI
Charger	(V/A)	Standard 480v 3phase Optional 220V
Driving Motor	(K/W)	11
Lifting Motor	(K/W)	12
Battery voltage	(V/Ah)	48V/600AH LEAD ACID
Service Weight	(lb.)	10,650

The EKKO EK25GB Wheel Electric Forklift is designed for use for all your material handling demands. It is ideal for loading and unloading trucks, loading docks, stock rooms, manufacturing floors and warehousing.

Made from high quality steel and components with durable quality drives to withstand any terrain, usage, impact and directional changes for the use of any application with confidence and assurance.

- Load Capacity 5000 lb.
- Raised Height 189" (15.75ft)
- Side Shifting Forks
- Free Lift 47.48"
- Fork Length 42"
- ZAPI Controller
- Battery 48/600AH Lead Acid
- Solid Pneumatic Tires
- Ergonomic Handle and Controls
- Steel Construction
- Robotic Welding
- 3-Phase 480V Charger (optional 220V)
- 3 Year Limited Warranty

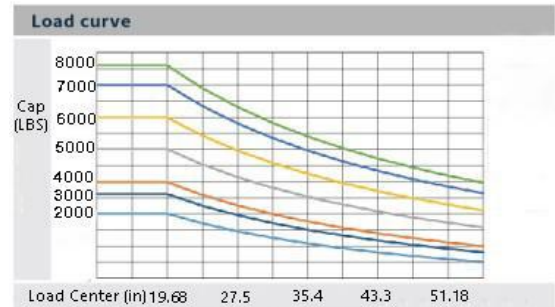
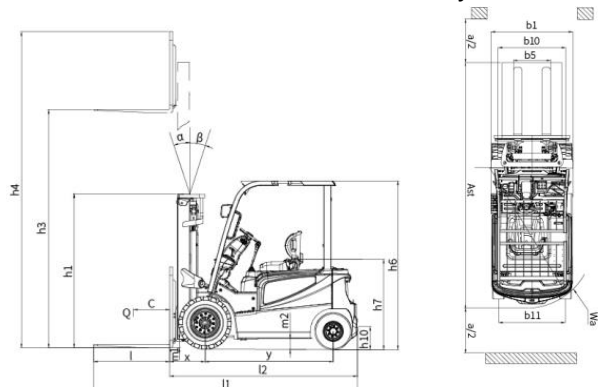

## EK25GHB 4 Wheel Electric Forklift

Model		EK25GHB
Lift		Electric
Drive		Sit-Down
Load capacity	(lb.)	5000
Load center distance	(in)	20
Wheelbase	(in)	65.35
Lifting height	(in)	212
Free lifting height	(in)	54.9
Lowered mast height	(in)	94.5
Mast/Fork carriage tilt forward/backward	( ° )	6/6
Side Shift		3-way valve
Overall length	(in)	138
Overall width	(in)	46.45
Fork size,	(in)	42
Turning radius	(in)	84.2
Max gradient performance, laden/unladen	(%)	15/25
ZAPI Controller		ZAPI
Charger	(V/A)	Standard 480v 3phase Optional 220V
Driving Motor	(K/W)	11
Lifting Motor	(K/W)	12
Battery voltage	(V/Ah)	48V/600AH LEAD ACID
Service Weight	(lb.)	10,650

The EKKO EK25GHB Wheel Electric Forklift is designed for use for all your material handling demands. It is ideal for loading and unloading trucks, loading docks, stock rooms, manufacturing floors and warehousing.

Made from high quality steel and components with durable quality drives to withstand any terrain, usage, impact and directional changes for the use of any application with confidence and assurance.

- Load Capacity 5000 lb.
- Raised Height 212"
- Side Shifting Forks
- Free Lift 47.48"
- Fork Length 42"
- ZAPI Controller
- Battery 48/600 AH Lead acid
- Solid Pneumatic Tires
- Ergonomic Handle and Controls
- Steel Construction
- Robotic Welding
- 3-Phase 480V Charger (optional 220V)
- 3 Year Limited Warranty

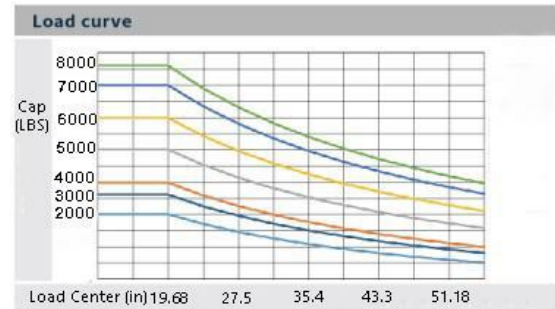
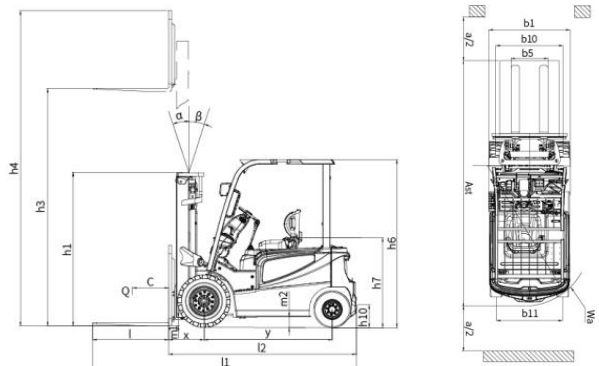



## EK30GB 4 Wheel Electric Forklift

Model		EK30GB
Lift		Electric
Drive		Sit-Down
Load capacity	(lb.)	6000
Load center distance	(in)	20
Wheelbase	(in)	68.9
Lifting height	(in)	189
Free lifting height	(in)	40.94
Lowered mast height	(in)	83
Mast/Fork carriage tilt forward/backward	( ° )	6/6
Side Shift		3-way valve
Overall length	(in)	135.3
Overall width	(in)	49.6
Fork size,	(in)	42
Turning radius	(in)	87.9
Max gradient performance, laden/unladen	(%)	17/26
ZAPI Controller		ZAPI
Charger	(V/A)	Standard 480v 3phase Optional 220V
Driving Motor	(K/W)	15
Lifting Motor	(K/W)	16
Battery voltage	(V/Ah)	48V/600AH LEAD ACID
Service Weight	(lb.)	10,795

The EKKO EK30GB Wheel Electric Forklift is designed for use for all your material handling demands. It is ideal for loading and unloading trucks, loading docks, stock rooms, manufacturing floors and warehousing.

Made from high quality steel and components with durable quality drives to withstand any terrain, usage, impact and directional changes for the use of any application with confidence and assurance.

- Solid Pneumatic Tires
- Ergonomic Handle and Controls
- Steel Construction
- Robotic Welding
- 3-Phase 480V Charger (optional 220V)
- 3 Year Limited Warranty
- ZAPI Controller
- Side Shifting forks.

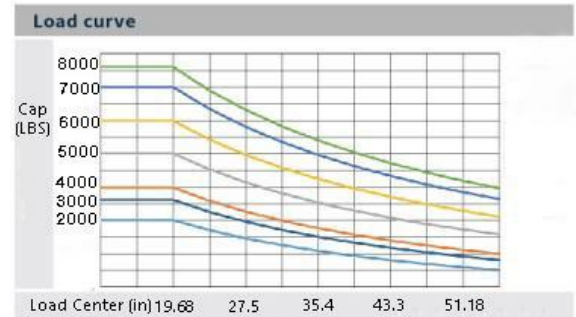
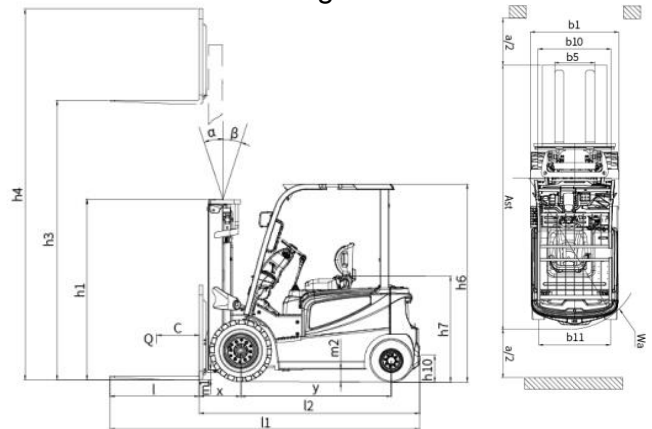

## EK35GB 4 Wheel Electric Forklift

Model		EK35GB
Lift		Electric
Drive		Sit-Down
Load capacity	(lb.)	7000
Load center distance	(in)	20
Wheelbase	(in)	68.9
Lifting height	(in)	189
Free lifting height	(in)	40.94
Lowered mast height	(in)	83
Mast/Fork carriage tilt forward/backward	( ° )	6/6
Side Shift		3-way valve
Overall length	(in)	136.3
Overall width	(in)	49.6
Fork size,	(in)	42
Turning radius	(in)	87.9
Max gradient performance, laden/unladen	(%)	15/23
ZAPI Controller		ZAPI
Charger	(V/A)	Standard 480v 3phase Optional 220V
Driving Motor	(K/W)	15
Lifting Motor	(K/W)	16
Battery voltage	(V/Ah)	48V/600AH LEAD ACID
Service Weight	(lb.)	11,408

The EKKO EK35GB Wheel Electric Forklift is designed for use for all your material handling demands. It is ideal for loading and unloading trucks, loading docks, stock rooms, manufacturing floors and warehousing.

Made from high quality steel and components with durable quality drives to withstand any terrain, usage, impact and directional changes for the use of any application with confidence and assurance.

- Solid Pneumatic Tires
- Ergonomic Handle and Controls
- Steel Construction
- Robotic Welding
- 3-Phase 480V Charger (optional 220V)
- 3 Year Limited Warranty
- ZAPI Controller
- Side Shifting forks.

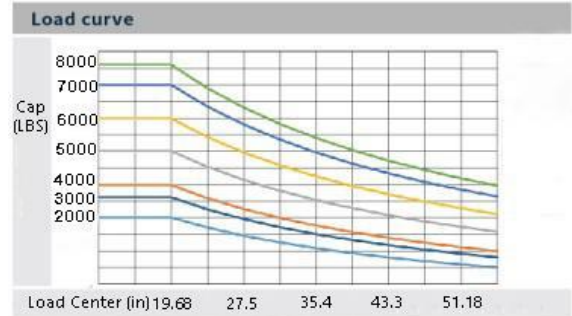
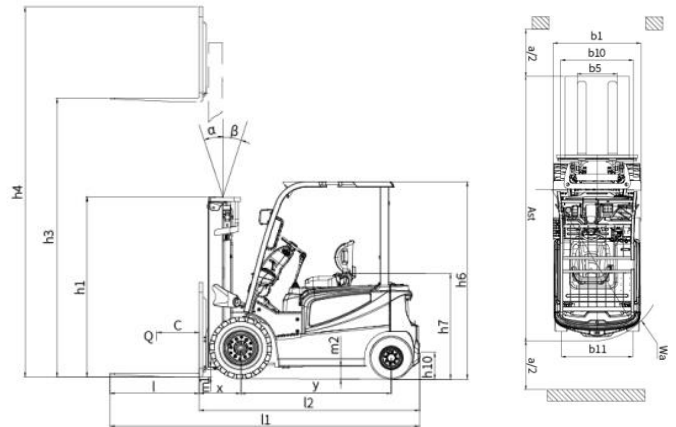

## EK18G-LI 4 Wheel Lithium Forklift

Model		EK18G-LI
Lift		Lithium
Drive		Sit-Down
Load capacity	(lb.)	4000
Load center distance	(in)	20
Wheelbase	(in)	65.4
Lifting height	(in)	189
Free lifting height	(in)	47.48
Lowered mast height	(in)	79
Mast/Fork carriage tilt forward/backward	( ° )	6/6
Side Shift		3-way valve
Overall length	(in)	133
Overall width	(in)	46.45
Fork Size,	(in)	42
Tire Material		Solid Pneumatic
Turning radius	(in)	85
Drive speed	(mph)	9/9.3
Laden/unladen		
Ground Clearance at mast	(in)	3.95
ZAPI Controller		ZAPI
Battery voltage	(V/Ah)	80V/150AH Lithium
Service Weight	(lb.)	9,200

The EKKO EK18G-LI 4 Wheel Electric Forklift is designed for use for all your material handling demands. It is ideal for loading and unloading trucks, loading docks, stock rooms, manufacturing floors and warehousing.

Made from high quality steel and components with durable quality drives to withstand any terrain, usage, impact and directional changes for the use of any application with confidence and assurance.

- Load Capacity 4000 lb.
- Raised Height 189" (15.75ft)
- Side Shifting Forks
- ZAPI Controller
- Battery 80/150 Ah Lithium
- Solid Pneumatic Tires
- Ergonomic Handle and Controls
- 3-Phase 480V Charger (optional 220V & 110V)
- 3 Year Limited Warranty

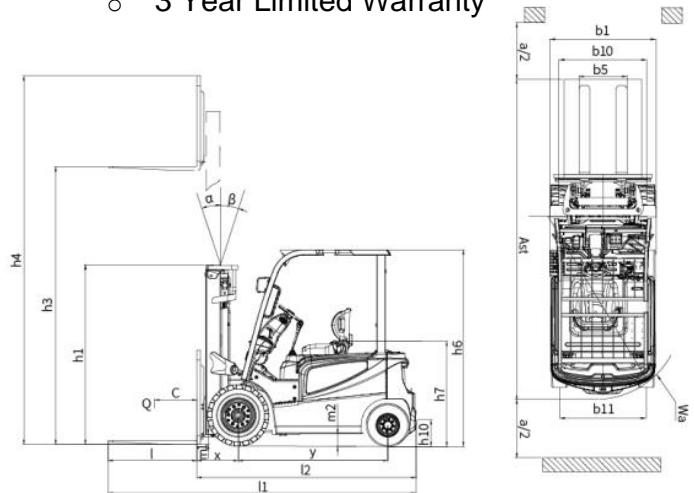

Load curve

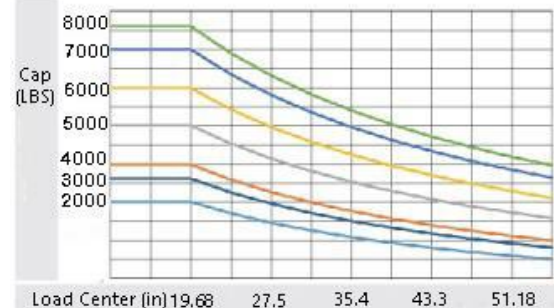

# EK18G-212LI 4 Wheel Lithium Forklift

Model		EK18G-212LI
Lift		Lithium
Drive		Sit-Down
Load capacity	(lb.)	4000
Load center distance	(in)	20
Wheelbase	(in)	65.4
Lifting height	(in)	212
Free lifting height	(in)	47.48
Lowered mast height	(in)	79
Mast/Fork carriage tilt forward/backward	( ° )	6/6
Side Shift		3-way valve
Overall length	(in)	133
Overall width	(in)	46.45
Fork Size,	(in)	42
Tire Material		Solid Pneumatic
Turning radius	(in)	85
Drive speed Laden/unladen	(mph)	9/9.3
Ground Clearance at mast	(in)	3.95
ZAPI Controller		ZAPI
Battery voltage	(V/Ah)	80V/150AH Lithium
Service Weight	(lb.)	9,200

The EKKO EK18G-212LI 4 Wheel Electric Forklift is designed for use for all your material handling demands. It is ideal for loading and unloading trucks, loading docks, stock rooms, manufacturing floors and warehousing.

Made from high quality steel and components with durable quality drives to withstand any terrain, usage, impact and directional changes for the use of any application with confidence and assurance.

- Load Capacity 4000 lb.
- Raised Height 212" (17.67 ft)
- Side Shifting Forks
- ZAPI Controller
- Battery 80/150 Ah Lithium
- Solid Pneumatic Tires
- Ergonomic Handle and Controls
- 3-Phase 480V Charger (optional 220V & 110V)
- 3 Year Limited Warranty

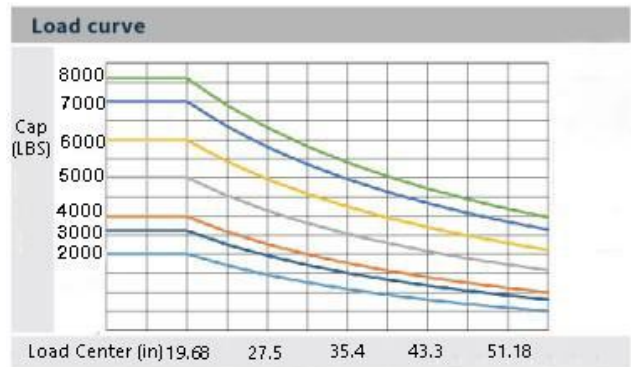
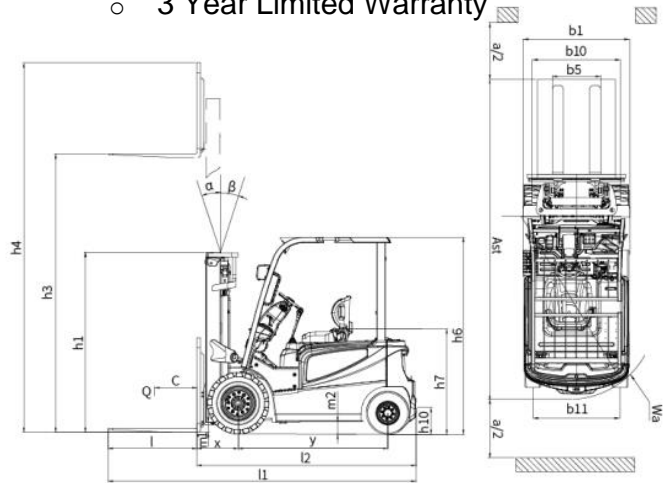

## EK20G-LI 4 Wheel Lithium Forklift

Model		EK20G-LI
Lift		Lithium
Drive		Sit-Down
Load capacity	(lb.)	4500
Load center distance	(in)	20
Wheelbase	(in)	65.4
Lifting height	(in)	189
Free lifting height	(in)	47.48
Lowered mast height	(in)	79
Mast/Fork carriage tilt forward/backward	( ° )	6/6
Side Shift		3-way valve
Overall length	(in)	133
Overall width	(in)	46.45
Fork Size,	(in)	42
Tire Material		Solid Pneumatic
Turning radius	(in)	85
Drive speed	(mph)	9/9.3
Laden/unladen		
Ground Clearance at mast	(in)	3.95
ZAPI Controller		ZAPI
Battery voltage	(V/Ah)	80V/202AH Lithium
Service Weight	(lb.)	9,420

The EKKO EK20G-LI 4 Wheel Electric Forklift is designed for use for all your material handling demands. It is ideal for loading and unloading trucks, loading docks, stock rooms, manufacturing floors and warehousing.

Made from high quality steel and components with durable quality drives to withstand any terrain, usage, impact and directional changes for the use of any application with confidence and assurance.

- Load Capacity 4500 lb.
- Raised Height 189" (15.75ft)
- Side Shifting Forks
- ZAPI Controller
- Battery 80/202 Ah Lithium
- Solid Pneumatic Tires
- Ergonomic Handle and Controls
- 3-Phase 480V Charger (optional 220V & 110V)
- 3 Year Limited Warranty

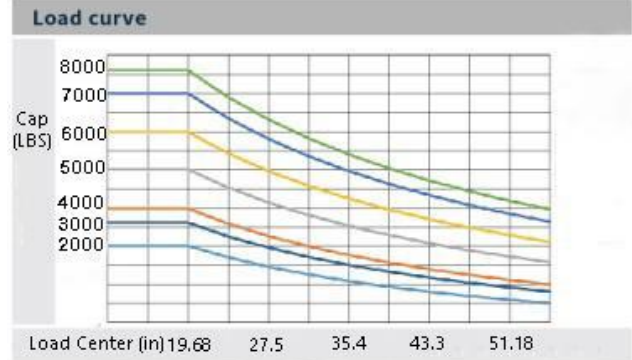

## EK25G-LI 4 Wheel Lithium Forklift

Model		EK25G-LI
Lift		Lithium
Drive		Sit-Down
Load capacity	(lb.)	4500
Load center distance	(in)	20
Wheelbase	(in)	65.35
Lifting height	(in)	189
Free lifting height	(in)	47.48
Lowered mast height	(in)	83
Mast/Fork carriage tilt forward/backward	( ° )	6/6
Side Shift		3-way valve
Overall length	(in)	137.95
Overall width	(in)	46.45
Fork Size,	(in)	42
Tire Material		Solid Pneumatic
Turning radius	(in)	84.2
Max Gradient Performance, laden/unladen	(%)	15/25
Fork Adjust Width	(in)	8.7-29
ZAPI Controller		ZAPI
Battery voltage	(V/Ah)	80V/202AH Lithium
Service Weight	(lb.)	9,782

The EKKO EK25G-LI 4 Wheel Electric Forklift is designed for use for all your material handling demands. It is ideal for loading and unloading trucks, loading docks, stock rooms, manufacturing floors and warehousing.

Made from high quality steel and components with durable quality drives to withstand any terrain, usage, impact and directional changes for the use of any application with confidence and assurance.

- Load Capacity 5000 lb.
- Raised Height 189" (15.75ft)
- Side Shifting Forks
- Free Lift 47.48"
- Fork Length 42"
- ZAPI Controller
- Battery 80/202 Ah Lithium
- Solid Pneumatic Tires
- 3-Phase 480V Charger (optional 220V & 110V)
- 3 Year Limited Warranty

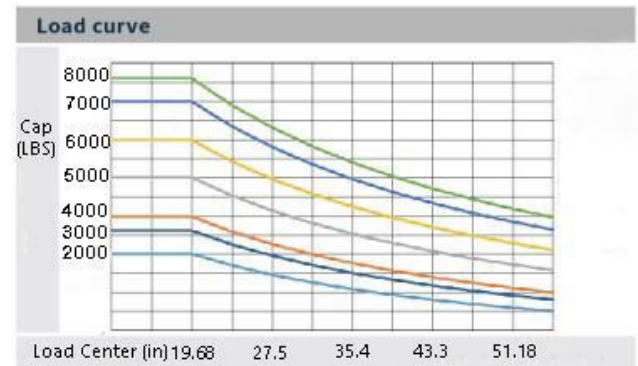
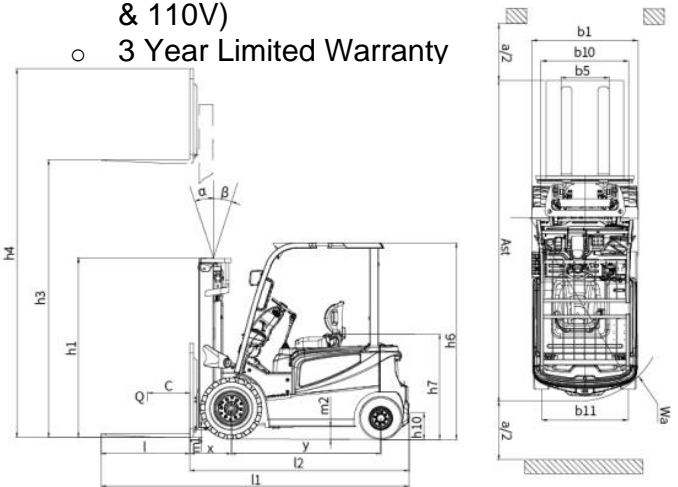

# EK25G-212LI 4 Wheel Lithium Forklift

Model		EK25G-212LI
Lift		Lithium
Drive		Sit-Down
Load capacity	(lb.)	5000
Load center distance	(in)	20
Wheelbase	(in)	65.35
Lifting height	(in)	212
Free lifting height	(in)	54.9
Lowered mast height	(in)	94.5
Mast/Fork carriage tilt forward/backward	( ° )	6/6
Side Shift		3-way valve
Overall length	(in)	138
Overall width	(in)	46.45
Fork Size,	(in)	42
Tire Material		Solid Pneumatic
Turning radius	(in)	84.2
Max Gradient Performance, laden/unladen	(%)	15/25
Fork Adjust Width	(in)	8.7-29
ZAPI Controller		ZAPI
Battery voltage	(V/Ah)	80V/202AH Lithium
Service Weight	(lb.)	9,915

The EKKO EK25G-212LI 4 Wheel Electric Forklift is designed for use for all your material handling demands. It is ideal for loading and unloading trucks, loading docks, stock rooms, manufacturing floors and warehousing.

Made from high quality steel and components with durable quality drives to withstand any terrain, usage, impact and directional changes for the use of any application with confidence and assurance.

- Load Capacity 5000 lb.
- Raised Height 212"
- Side Shifting Forks
- Free Lift 47.48"
- Fork Length 42"
- ZAPI Controller
- Battery 80/202 Ah Lithium
- Solid Pneumatic Tires
- Ergonomic Handle and Controls
- 3-Phase 480V Charger (optional 220V & 110V)

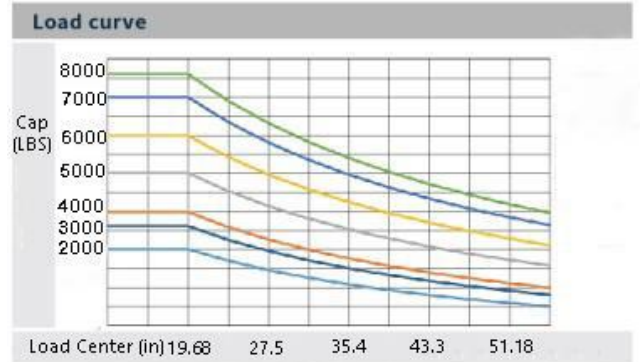
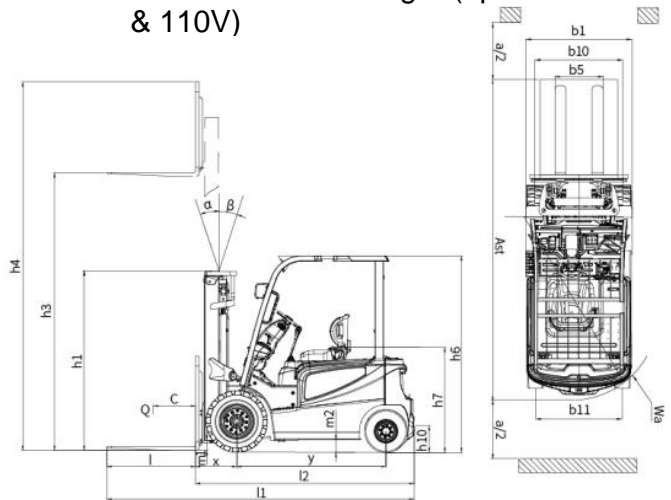

## EK30G-LI 4 Wheel Lithium Forklift

Model		EK30G-LI
Lift		Lithium
Drive		Sit-Down
Load capacity	(lb.)	6000
Load center distance	(in)	20
Wheelbase	(in)	68.9
Lifting height	(in)	189
Free lifting height	(in)	40.94
Lowered mast height	(in)	83
Mast/Fork carriage tilt forward/backward	( ° )	6/6
Side Shift		3-way valve
Overall length	(in)	143.2
Overall width	(in)	49.6
Fork Size,	(in)	42
Tire Material		Solid Pneumatic
Turning radius	(in)	87.9
Max Gradient Performance, laden/unladen	(%)	17/26
Fork Adjust Width	(in)	8.7-29
ZAPI Controller		ZAPI
Battery voltage	(V/Ah)	80V/250AH Lithium
Service Weight	(lb.)	10,596

The EKKO EK30G-LI 4 Wheel Electric Forklift is designed for use for all your material handling demands. It is ideal for loading and unloading trucks, loading docks, stock rooms, manufacturing floors and warehousing.

Made from high quality steel and components with durable quality drives to withstand any terrain, usage, impact and directional changes for the use of any application with confidence and assurance.

- Load Capacity 6000 lb.
- Raised Height 189" (15.75ft)
- Side Shifting Forks
- Free Lift 40.94"
- Fork Length 42"
- ZAPI Controller
- Battery 80/250 Ah Lithium
- Solid Pneumatic Tires
- 3-Phase 480V Charger (optional 220V & 110V)
- 3 Year Limited Warranty

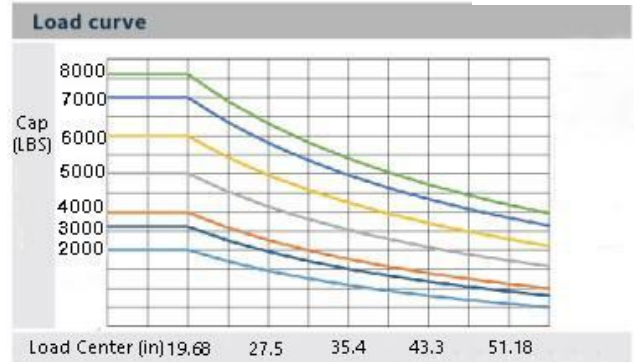
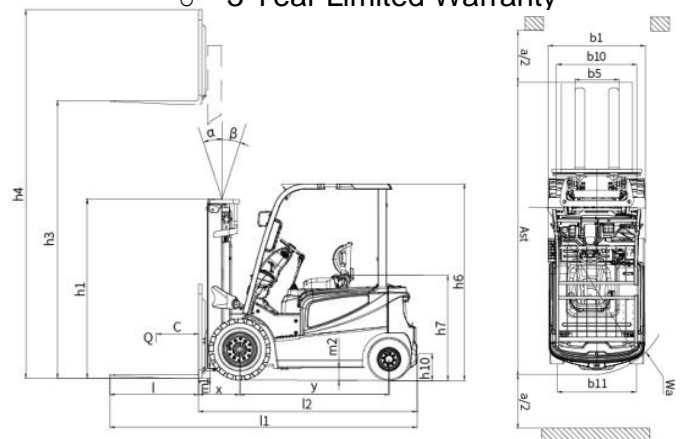



## EK35G-LI 4 Wheel Lithium Forklift

Model		EK35G-LI
Lift		Lithium
Drive		Sit-Down
Load capacity	(lb.)	7000
Load center distance	(in)	20
Wheelbase	(in)	68.9
Lifting height	(in)	189
Free lifting height	(in)	40.94
Lowered mast height	(in)	83
Mast/Fork carriage tilt forward/backward	( ° )	6/6
Side Shift		3-way valve
Overall length	(in)	143.4
Overall width	(in)	49.6
Fork Size,	(in)	42
Tire Material		Solid Pneumatic
Turning radius	(in)	87.9
Max Gradient Performance, laden/unladen	(%)	15/23
Fork Adjust Width	(in)	8.7-29
ZAPI Controller		ZAPI
Battery voltage	(V/Ah)	80V/250AH Lithium
Service Weight	(lb.)	11,208

The EKKO EK35G-LI 4 Wheel Electric Forklift is designed for use for all your material handling demands. It is ideal for loading and unloading trucks, loading docks, stock rooms, manufacturing floors and warehousing.

Made from high quality steel and components with durable quality drives to withstand any terrain, usage, impact and directional changes for the use of any application with confidence and assurance.

- Load Capacity 7000 lb.
- Raised Height 189" (15.75ft)
- Side Shifting Forks
- ZAPI Controller
- Battery 80/250 Ah Lithium
- Solid Pneumatic Tires
- 3-Phase 480V Charger (optional 220V & 110V)
- 3 Year Limited Warranty

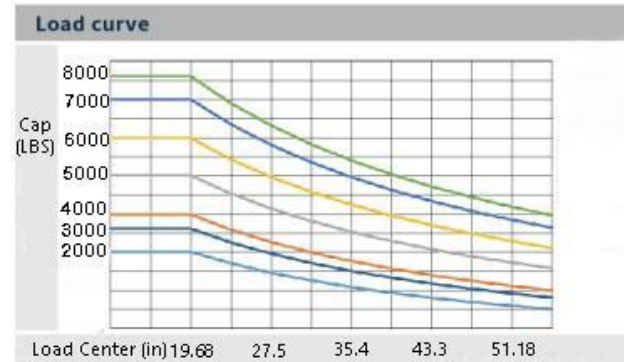
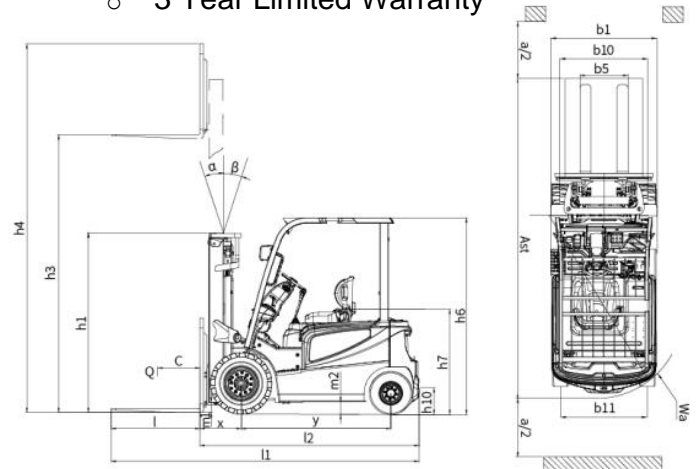

## EK50G-LI 4 Wheel Lithium Forklift

Model		EK50G-LI
Lift		Lithium
Drive		Sit-Down
Load capacity	(lb.)	10,000
Load center distance	(in)	
Wheelbase	(in)	
Lifting height	(in)	189
Free lifting height	(in)	
Lowered mast height	(in)	
Mast/Fork carriage tilt forward/backward	( ° )	
Side Shift		3-way valve
Overall length	(in)	
Overall width	(in)	
Fork size,	(in)	42
Fork adjust width	(in)	
Turning radius	(in)	
Max gradient performance, laden/unladen	(%)	
Lift speed, laden/unladen	(in/s)	
ZAPI Controller		ZAPI
Charger	(V/A)	
AC Driving Motor	(K/W)	
Lifting Motor	(K/W)	
Battery voltage	(V/Ah)	80V/604AH Lithium
Service Weight	(lb.)	16,800

More  
information  
coming soon!!

**COMING  
SOON**



## EK18RF Stand-up Rider Forklift

Model		EK18RF
Lift		Electric
Drive		Electric
Load capacity	(lb.)	4000
Load center distance	(in)	24
Wheelbase	(in)	48.8
Lifting height	(in)	216
Free lifting height	(in)	61.34
Lowered mast height	(in)	91.77
Mast/Fork carriage tilt forward/backward	( ° )	3/5
Side Shifting Forks		3-way valve
Overall length	(in)	72.52
Overall width	(in)	42.52
Fork size, Thick/Width/Length	(in)	1.58/4.72/45
Fork adjust width	(in)	35
Turning radius	(in)	58.5
Max gradient performance, laden/unladen	(%)	6/10
Lift speed, laden/unladen	(in/s)	9.8/15
Lowering speed, laden/unladen	(in/s)	9.5/10.2
Charger	(V/A)	48V/65A
Driving Motor	(V/W)	ZF AC 48/6000
Lifting Motor	(V/W)	48/7700
Battery voltage	(V/Ah)	48V/420Ah (Side)
Service Weight	(lb.)	7940

The EKKO EK18RF Stand-up Forklift is designed for use for small aisles, limited spaces and budget. It is ideal for loading and unloading trucks, loading docks, stock rooms, manufacturing floors and warehousing.

Made from high quality steel and components with durable quality drives to withstand any terrain, usage, impact and directional changes for the use of any application with confidence and assurance.

- Load Capacity 4000 lb.
- Raised Height 216" (18ft)
- Side Shifting
- Free Lift 61.34"
- Adjustable Forks 8.7-35"
- Fork Length 45"
- Overhead Guard 90.08"
- EPS (Electric Power Steering)
- Curtis Instrument Controller
- 48V AC Drive Motor
- 48V Lift Motor
- Battery 48V/420Ah
- Solid Wheels
- Ergonomic Handle and Controls
- Steel Construction
- Robotic Welding
- Charger 48V/65A
- 3 Year Limited Warranty

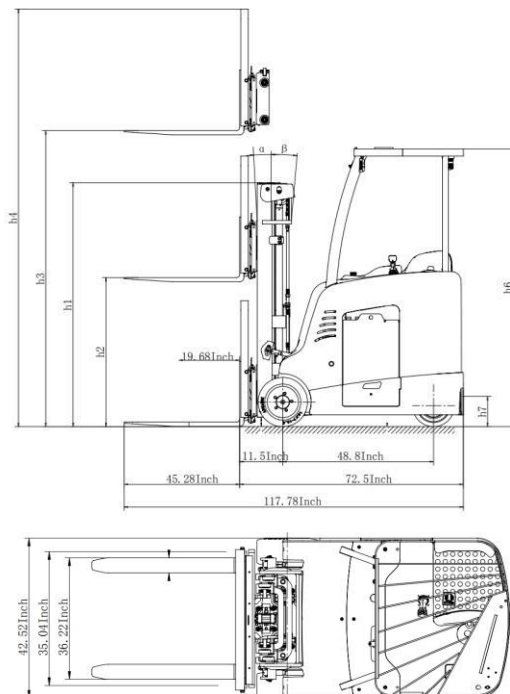

## EK18RFL Stand-up Rider Forklift

Model		EK18RFL
Lift		Electric
Drive		Electric
Load capacity	(lb.)	4000
Load center distance	(in)	24
Wheelbase	(in)	48.8
Lifting height	(in)	189
Free lifting height	(in)	52.17
Lowered mast height	(in)	82.6
Mast/Fork carriage tilt forward/backward	( ° )	3/5
Side Shifting Forks		3-way valve
Overall length	(in)	72.52
Overall width	(in)	42.52
Fork size, Thick/Width/Length	(in)	1.58/4.72/45
Fork adjust width	(in)	35
Turning radius	(in)	58.5
Max gradient performance, laden/unladen	(%)	6/10
Lift speed, laden/unladen	(in/s)	9.8/15
Lowering speed, laden/unladen	(in/s)	9.5/10.2
Charger	(V/A)	48V/65A
Driving Motor	(V/W)	ZF AC 48/6000
Lifting Motor	(V/W)	48/7700
Battery voltage	(V/Ah)	48V/420Ah (Side)
Service Weight	(lb.)	7870

The EKKO EK18RFL Stand-up Rider Forklift is designed for use for all your material handling demands. It is ideal for loading and unloading trucks, loading docks, stock rooms, manufacturing floors and warehousing.

Made from high quality steel and components with durable quality drives to withstand any terrain, usage, impact and directional changes for the use of any application with confidence and assurance.

- Raised Height 189" (15.75ft)
- Side Shifting Forks
- Adjustable Forks 9.4-35.6"
- Hydraulic Steering
- Curtis Instrument Controller
- German AC Drive Motor
- Solid Cushion Load Tires
- Polyurethane Drive Tires
- Ergonomic Handle and Controls
- Steel Construction
- Robotic Welding
- 3 Year Limited Warranty

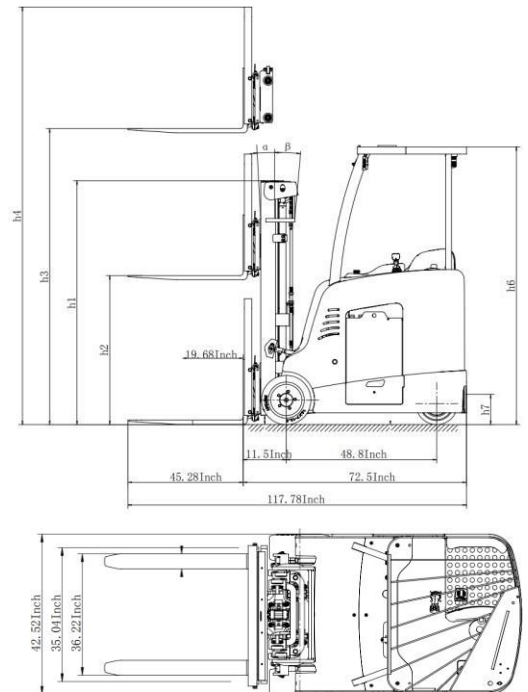

## EK18F-212LI Stand-up Rider Forklift

Model		EK18F-212LI
Lift		Electric
Drive		Electric
Load capacity	(lb.)	4000
Load center distance	(in)	
Wheelbase	(in)	
Lifting height	(in)	212
Free lifting height	(in)	
Lowered mast height	(in)	
Mast/Fork carriage tilt forward/backward	( ° )	
Side Shifting Forks		3-way valve
Overall length	(in)	
Overall width	(in)	
Fork size, Thick/Width/Length	(in)	
Fork adjust width	(in)	
Turning radius	(in)	
Max gradient performance, laden/unladen	(%)	
Lift speed, laden/unladen	(in/s)	
Lowering speed, laden/unladen	(in/s)	
Charger	(V/A)	
AC Driving Motor	(V/W)	
Controller		ZAPI
Battery voltage	(V/Ah)	48V/404Ah Lithium
Service Weight	(lb.)	8150

More information coming soon!!

**COMING SOON**



## EK13A 3 Wheel Electric Forklift

Model		EK13A
Lift		Electric
Drive		Electric
Load capacity	(lb.)	3300
Load center distance	(in)	24
Wheelbase	(in)	43
Lifting height	(in)	138
Free lifting height	(in)	4
Lowered mast height	(in)	88.4
Mast/Fork carriage tilt forward/backward	( ° )	2/5
Side Shifting Forks		3-way valve
Overall length	(in)	105
Overall width	(in)	36
Fork size, Thick/Width/Length	(in)	1.4/4/45.3
Fork adjust width	(in)	8.7-29
Turning radius	(in)	53
Max gradient performance, laden/unladen	(%)	6/8
Lift speed, laden/unladen	(in/s)	4/5.5
Lowering speed, laden/unladen	(in/s)	5.3/4.7
Charger	(V/A)	24V/50A
Driving Motor	(V/W)	AC 24V/2000W
Lifting Motor	(V/W)	24V/2500W
Battery voltage	(V/Ah)	24V/350Ah (Side)
Service Weight	(lb.)	5200

The EKKO EK13A 3 Wheel Electric Forklift is designed for use for small aisles, limited spaces and budget. It is ideal for loading and unloading trucks, loading docks, stock rooms, manufacturing floors and warehousing.

Made from high quality steel and components with durable quality drives to withstand any terrain, usage, impact and directional changes for the use of any application with confidence and assurance.

- Load Capacity 3300 lb.
- Raised Height 138" (11.5ft)
- Side Shifting
- Adjustable Forks 8.7-29"
- Fork Length 45.3"
- Overhead Guard 77"
- EPS (Electric Power Steering)
- Curtis Instrument Controller
- 24V AC Drive Motor
- 24V Lift Motor
- Battery 24V/350Ah
- Solid Wheels
- Ergonomic Handle and Controls
- Steel Construction
- Robotic Welding
- 3 year Limited Warranty

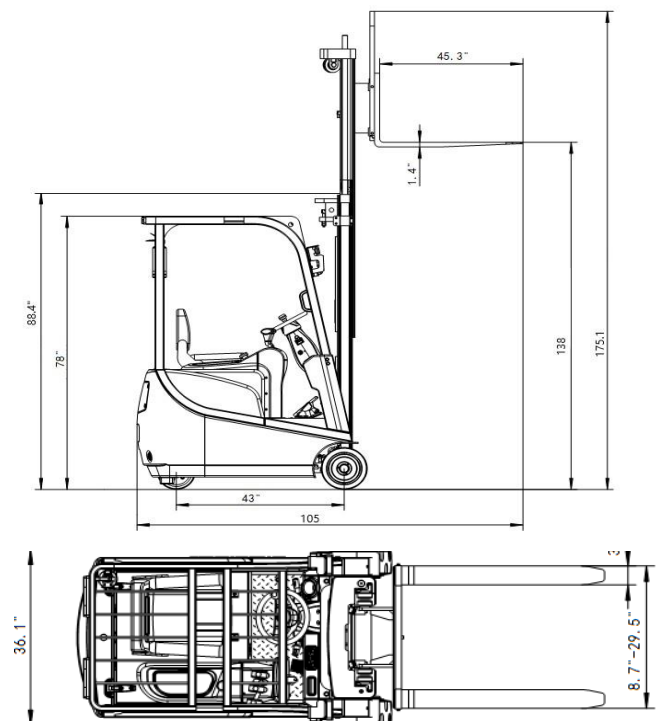

## EK15A 3 Wheel Electric Forklift

Model		EK15A
Lift		Electric
Drive		Electric
Load capacity	(lb.)	3300
Load center distance	(in)	24
Wheel base	(in)	43
Lifting height	(in)	177
Free lifting height	(in)	59
Lowered mast height	(in)	79.6
Mast/Fork carriage tilt forward/backward	( ° )	2/5
Side Shifting Forks		3-way valve
Overall length	(in)	106.6
Overall width	(in)	36
Fork size, Thick/Width/Length	(in)	1.4/4/45.3
Fork adjust width	(in)	8.7-29
Turning radius	(in)	53
Max gradient performance, laden/unladen	(%)	6/8
Lift speed, laden/unladen	(in/s)	4/5.5
Lowering speed, laden/unladen	(in/s)	5.3/4.7
Charger	(V/A)	24V/50A
Driving Motor	(V/W)	AC 24V/2000W
Lifting Motor	(V/W)	24V/2500W
Battery voltage	(V/Ah)	24V/400Ah (Side)
Service Weight	(lb.)	5665

The EKKO EK15A 3 Wheel Electric Forklift is designed for use for small aisles, limited spaces and budget. It is ideal for loading and unloading trucks, loading docks, stock rooms, manufacturing floors and warehousing.

Made from high quality steel and components with durable quality drives to withstand any terrain, usage, impact and directional changes for the use of any application with confidence and assurance.

- Load Capacity 3300 lb.
- Raised Height 177" (14.75ft)
- Side Shifting
- Free Lift 59"
- Adjustable Forks 8.7-29"
- Fork Length 45.3"
- Overhead Guard 77"
- EPS (Electric Power Steering)
- Curtis Instrument Controller
- 24V AC Drive Motor
- 24V Lift Motor
- Battery 24V/400Ah
- Solid Wheels
- Ergonomic Handle and Controls
- Steel Construction
- Robotic Welding
- Charger 24V/50Ah
- 3 Year Limited Warranty

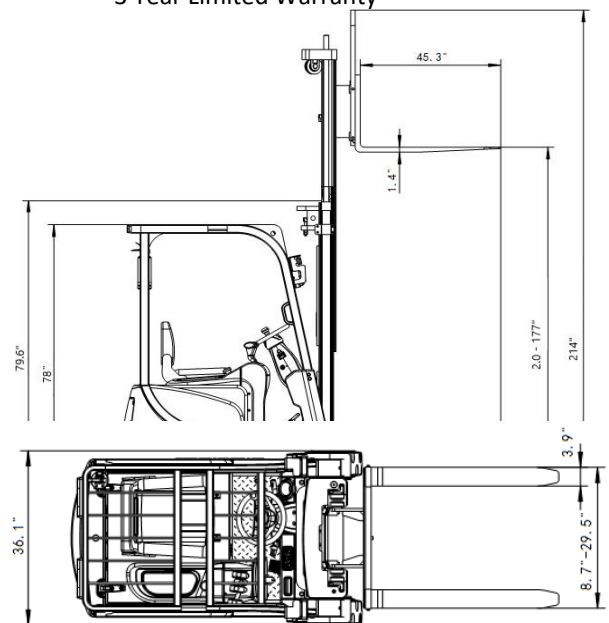

## EK15A-189Li 3 Wheel Lithium-Iron Forklift

Model		EK15A-189Li
Lift		Electric
Drive		Electric
Load capacity	(lb.)	3300
Load center distance	(in)	24
Wheel base	(in)	42.91
Lifting height	(in)	189
Free lifting height	(in)	62.56
Lowered mast height	(in)	83.54
Mast/Fork carriage tilt forward/backward	( ° )	2/5
Side Shifting Forks		3-way valve
Overall length	(in)	111.1
Overall width	(in)	36.1
Fork size, Thick/Width/Length	(in)	1.78/3.94/45.3
Fork adjust width	(in)	8.7-29
Turning radius	(in)	53.07
Max gradient performance, laden/unladen	(%)	6/10
Lift speed, laden/unladen	(in/s)	5.3/8.4
Lowering speed, laden/unladen	(in/s)	9.3/8.85
Charger		110 Plug in
Driving Motor	(V/W)	AC 24V/2000W
Lifting Motor	(V/W)	24V/2500W
Battery voltage	(V/Ah)	24V/350Ah Li
Service Weight	(lb.)	5560

The EKKO EK15A-189LI 3 Wheel Electric Forklift with lithium battery is designed for use for small aisles, limited spaces and budget. It is ideal for loading and unloading trucks, loading docks, stock rooms, manufacturing floors and warehousing.

Made from high quality steel and components with durable quality drives to withstand any terrain, usage, impact and directional changes for the use of any application with confidence and assurance. (Recommended for Indoor use on flat surfaces)

- Load Capacity 3300 lbs.
- Raised Height 189" (15.75ft)
- Free Lift 62.56"
- Side Shifting
- Adjustable Forks 8.66-33.74"
- Fork Length 45.3"
- Curtis Controller
- Tilt 2/5 Degree
- 24V AC Drive Motor
- 24V Lift Motor
- Cushion Wheels
- Ergonomic Handle and Controls
- EPS (Electronic Power Steering)
- Steel Construction
- Robotic Welding
- Charger Included
- Batteries Included
- 3 Years Limited Warranty

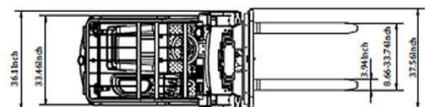
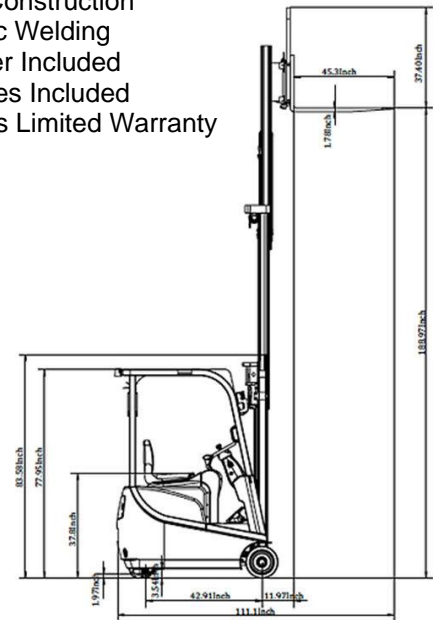



## EK18A-189LI 3 Wheel Electric Forklift

Model		EK18A-189Li
Lift		Electric
Drive		Electric
Load capacity	(lb.)	4,000
Load center distance	(in)	24
Wheel base	(in)	55.1
Lifting height	(in)	189
Free lifting height	(in)	46.5
Lowered mast height	(in)	86.2
Mast/Fork carriage tilt forward/backward	( ° )	3/5
Side Shifting Forks		3-way valve
Overall length	(in)	116.9
Overall width	(in)	44.1
Fork size	(in)	42
Fork adjust width	(in)	8.7-29
Turning radius	(in)	65.9
Max gradient performance, laden/unladen	(%)	22/30
Lift speed, laden/unladen	(fpm)	78.7/118.1
Lowering speed, laden/unladen	(fpm)	114.2/98.4
Charger		Included
Driving Motor		AMOSFET
Lifting Motor	(HP)	18.8
Battery voltage	(V/Ah)	80V/202Ah Li
Service Weight	(lb.)	7,341

The EKKO E18A-189LI 3 Wheel Lithium Forklift is designed for use for all your material handling demands. It is ideal for loading and unloading trucks, loading docks, stock rooms, manufacturing floors and warehousing.

Made from high quality steel and components with durable quality drives to withstand any terrain, usage, impact and directional changes for the use of any application with confidence and assurance.

- Load Capacity 4000 lb.
- Raised Height 189" (15.75ft)
- Side Shifting Forks
- Free Lift 46.5"
- Adjustable Forks
- Hydraulic Steering
- ZAPI controller
- Battery 80V/202Ah Lithium (included)
- Solid Pneumatic Tires
- Ergonomic Handle and Controls
- Steel Construction
- Robotic Welding
- Charger Included
- 3 Year Limited Warranty

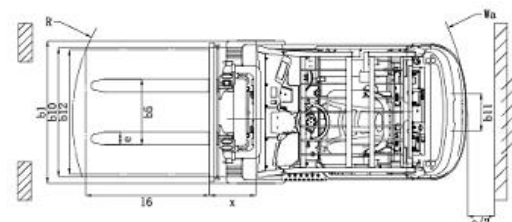
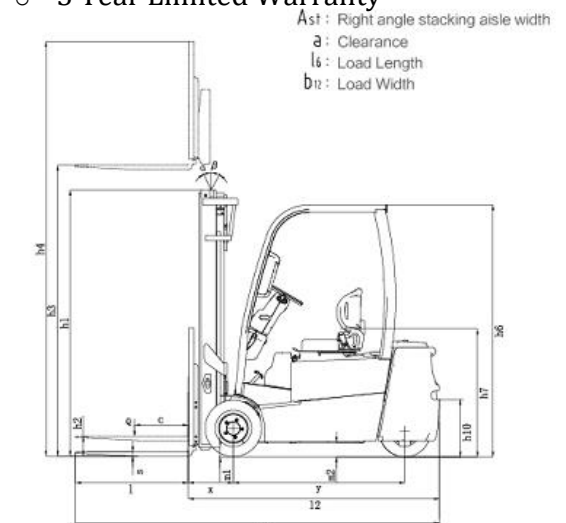

## EK18A-212LI 3 Wheel Electric Forklift

Model		EK18A-212Li
Lift		Electric
Drive		Electric
Load capacity	(lb.)	4,000
Load center distance	(in)	24
Wheel base	(in)	55.1
Lifting height	(in)	212
Free lifting height	(in)	46.5
Lowered mast height	(in)	95.5
Mast/Fork carriage tilt forward/backward	( ° )	3/5
Side Shifting Forks		3-way valve
Overall length	(in)	116.9
Overall width	(in)	44.1
Fork size	(in)	42
Fork adjust width	(in)	8.7-29
Turning radius	(in)	65.9
Max gradient performance, laden/unladen	(%)	22/30
Lift speed, laden/unladen	(fpm)	78.7/118.1
Lowering speed, laden/unladen	(fpm)	114.2/98.4
Charger		Included
Driving Motor		AMOSFET
Lifting Motor	(HP)	18.8
Battery voltage	(V/Ah)	80V/202Ah Li
Service Weight	(lb.)	8,105

The EKKO E18A-189LI 3 Wheel Lithium Forklift is designed for use for all your material handling demands. It is ideal for loading and unloading trucks, loading docks, stock rooms, manufacturing floors and warehousing.

Made from high quality steel and components with durable quality drives to withstand any terrain, usage, impact and directional changes for the use of any application with confidence and assurance.

- Load Capacity 4000 lb.
- Raised Height 212" (17.66ft)
- Side Shifting Forks
- Free Lift 46.5"
- Adjustable Forks
- Hydraulic Steering
- ZAPI controller
- Battery 80V/202Ah Lithium (included)
- Solid Pneumatic Tires
- Ergonomic Handle and Controls
- Steel Construction
- Robotic Welding
- Charger Included
- 3 Year Limited Warranty

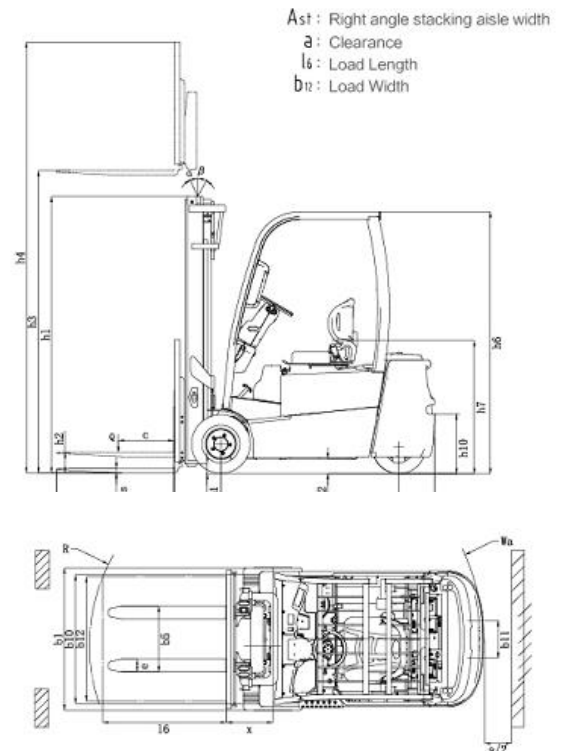

# ER15 Walkie Reach Truck



Model		ER15
Lift		Electric
Drive		Electric
Load capacity	(lb.)	3300
Load center distance	(in)	24
Lifting height	(in)	177
Side Shifting Forks		3 Way Valve
Free Lift	(in)	63
Lowered mast height	(in)	87.4
Overall length/Extended	(in)	94/113.8
Overall width	(in)	43.8
Fork size, Thick/Width/Length	(in)	1.38/3.9/45.3
Fork adjust width	(in)	7.9-33
Reach Distance	(in)	19.7
Turning radius	(in)	64
Charger	(V/A)	24V/40A
Driving Motor	(V/W)	AC 24V/3kw
EPS Steering Motor	(V/W)	24/200W
Lifting Motor	(V/W)	24V/3000W
Battery voltage	(V/Ah)	24V/350Ah
Service Weight	(lb.)	5500

The EKKO ER15 Walkie Reach Truck is designed with the combination of the versatility of a forklift, reach truck and a walkie stacker. It is ideal for loading and unloading trucks, loading docks, stock rooms, manufacturing floors and warehousing.

Made from high quality steel and components with durable quality drives to withstand any terrain, usage, impact and directional changes for the use of any application with confidence and assurance.

- Load Capacity 3300 lb.
- Side Shifting
- Raised Height 177" (14.75ft)
- Reach Distance of 19.7"
- Free Lift 63"
- Tilt 3/5 Degree
- Adjustable Forks 7.9-33"
- Fork Length 45.3"
- Curtis Instrument Controllers
- EPS (Electronic Power Steering)
- 24V AC Drive Motor
- 24V Lift Motor
- Battery 24V/350Ah
- Polyurethane Wheels
- Ergonomic Handle and Controls
- Steel Construction
- Robotic Welding
- Charger 24V/40A
- 3 Year Limited Warranty

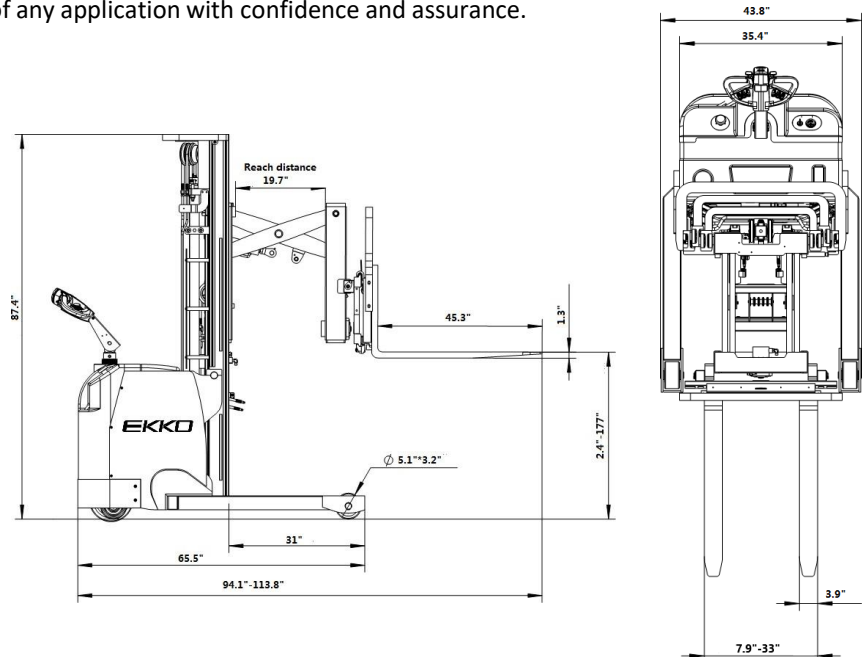

# ER15L Walkie Reach Truck



Model		ER15L
Lift		Electric
Drive		Electric
Load capacity	(lb.)	3300
Load center distance	(in)	24
Lifting height	(in)	138
Side Shifting Forks		3 Way Valve
Free Lift	(in)	N/A
Lowered mast height	(in)	90.5
Overall length/Extended	(in)	94/113.8
Overall width	(in)	43.8
Fork size, Thick/Width/Length	(in)	1.38/3.9/45.3
Fork adjust width	(in)	7.9-33
Reach Distance	(in)	19.7
Turning radius	(in)	64
Charger	(V/A)	24V/50A
Driving Motor	(V/W)	AC 24V/3kw
EPS Steering Motor	(V/W)	24/200W
Lifting Motor	(V/W)	24V/3000W
Battery voltage	(V/Ah)	24V/350Ah
Service Weight	(lb.)	4800

The EKKO ER15L Walkie Reach Truck is designed with the combination of the versatility of a forklift, reach truck and a walkie stacker. It is ideal for loading and unloading trucks, loading docks, stock rooms, manufacturing floors and warehousing.

Made from high quality steel and components with durable quality drives to withstand any terrain, usage, impact and directional changes for the use of any application with confidence and assurance.

- Load Capacity 3300 lb.
- Side Shifting
- Raised Height 138" (11.50ft)
- Reach Distance of 19.7"
- Tilt 3/5 Degree
- Adjustable Forks 7.9-33"
- Fork Length 45.3"
- Curtis Instrument Controller
- EPS (Electronic Power Steeri
- 24V AC Drive Motor
- 24V Lift Motor
- Battery 24V/350Ah
- Polyurethane Wheels
- Ergonomic Handle and Cont
- Steel Construction
- Robotic Welding
- Charger 24V/40A
- 3 Year Limited Warranty

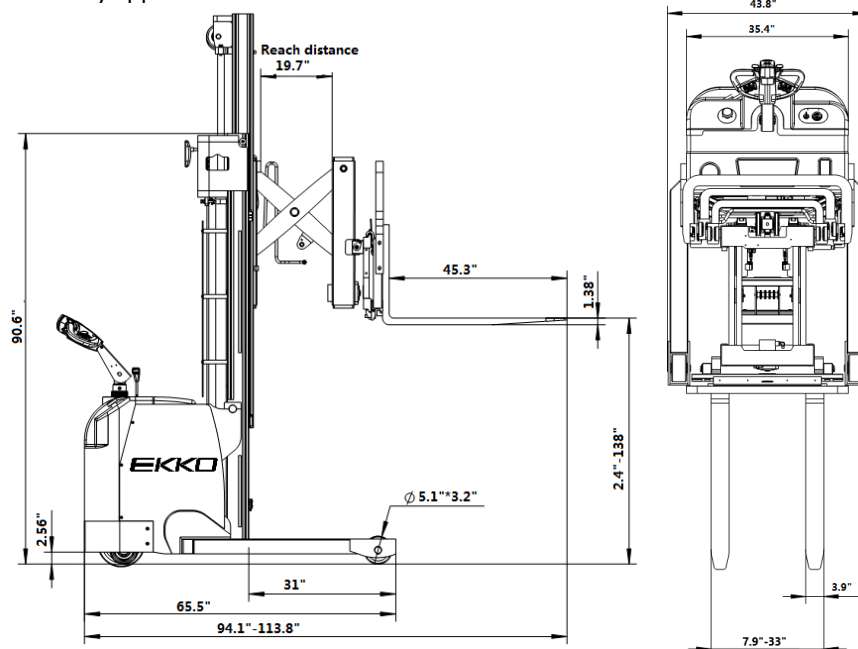

# EH15TH Moving Mast Walkie Reach Truck



Model		EH15TH
Lift		Electric
Drive		Electric
Load capacity	(lb.)	3300
Load center distance	(in)	24
Lifting height	(in)	216
Free Lift	(in)	68"
Lowered mast height	(in)	97.3
Overall length	(in)	111.6
Overall width	(in)	41
Fork size, Thick/Width/Length	(in)	1.4/4/45.2
Fork adjust width	(in)	8.7-28
Reach Distance	(in)	19.7
Turning radius	(in)	67
Charger	(V/A)	24V/50A
Driving Motor	(V/W)	AC 24V/2.5kw
EPS Steering Motor	(V/W)	24/200W
Lifting Motor	(V/W)	24V/3000W
Battery voltage	(V/Ah)	24V/400Ah
Service Weight	(lb.)	4915

The EKKO EH15TH Moving Mast Walkie Reach Truck is designed with the combination of the versatility of a forklift, reach truck and a walkie stacker. It is ideal for loading and unloading trucks, loading docks, stock rooms, manufacturing floors and warehousing.

Made from high quality steel and components with durable quality drives to withstand any terrain, usage, impact and directional changes for the use of any application with confidence and assurance.

- Load Capacity 3300 lb.
- Raised Height 216" (18ft)
- Reach Distance of 19.7"
- Free Lift 68"
- Adjustable Forks 8.7-29.7
- Fork Length 45.2"
- Curtis Instrument Control
- EPS (Electronic Power Steer)
- 24V AC Drive Motor
- 24V Lift Motor
- Battery 24V/400Ah
- Polyurethane Wheels
- Ergonomic Handle and Control
- Steel Construction
- Robotic Welding
- Charger
- 3 Year Limited Warranty

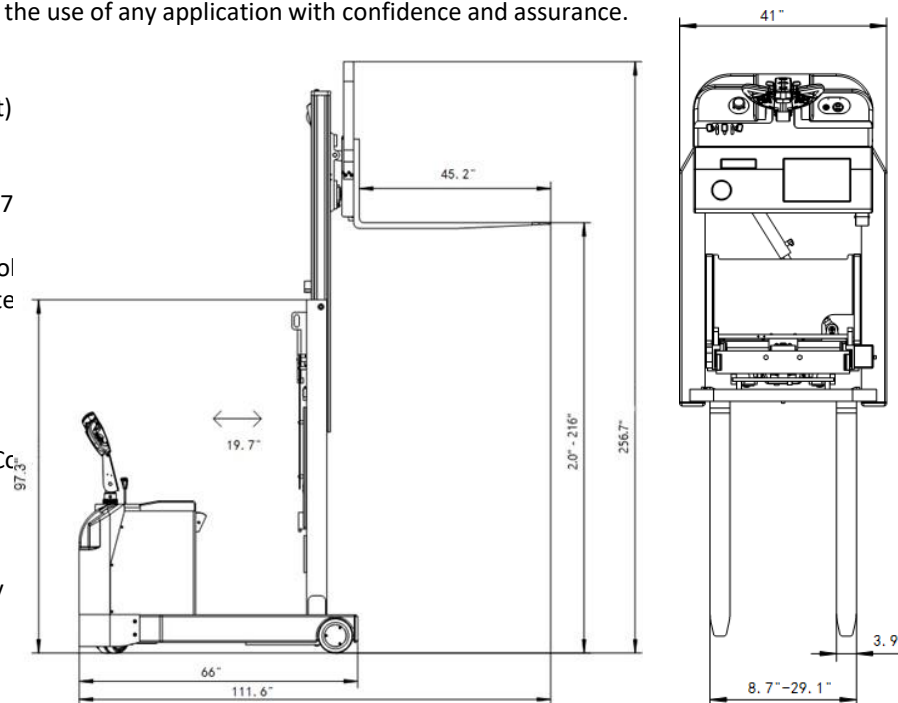

## EH15T Moving Mast Walkie Reach Truck



Model		EH15T
Lift		Electric
Drive		Electric
Load capacity	(lb.)	3300
Load center distance	(in)	24
Lifting height	(in)	138
Lowered mast height	(in)	93.3
Overall length	(in)	111.6
Overall width	(in)	41
Fork size, Thick/Width/Length	(in)	1.4/4/45.2
Fork adjust width	(in)	8.7-28
Reach Distance	(in)	19.7
Turning radius	(in)	67
Charger	(in)	24V/40A
Driving Motor	(V/A)	AC 24V/2500W
Steering Motor	(V/W)	24V/200W
Lifting Motor	(V/W)	24V/3000W
Battery voltage	(V/Ah)	24V/270Ah
Service Weight	(lb.)	4200

The EKKO EH15T Moving Mast Walkie Reach Truck is designed with the combination of the versatility of a forklift, reach truck and a walkie stacker. It is ideal for loading and unloading trucks, loading docks, stock rooms, manufacturing floors and warehousing.

Made from high quality steel and components with durable quality drives to withstand any terrain, usage, impact and directional changes for the use of any application with confidence and assurance.

- Load Capacity 3300 lb.
- Raised Height 138" (11.5ft)
- Reach Distance of 19.7"
- Adjustable Forks 8.7-29.1"
- Fork Length 45.3"
- Curtis Instrument Control
- EPS (Electronic Power Steer)
- 24V AC Drive Motor
- 24V Lift Motor
- Battery 24V/270Ah
- Polyurethane Wheels
- Ergonomic Handle and Control
- Steel Construction
- Robotic Welding
- Charger
- 3 Year Limited Warranty

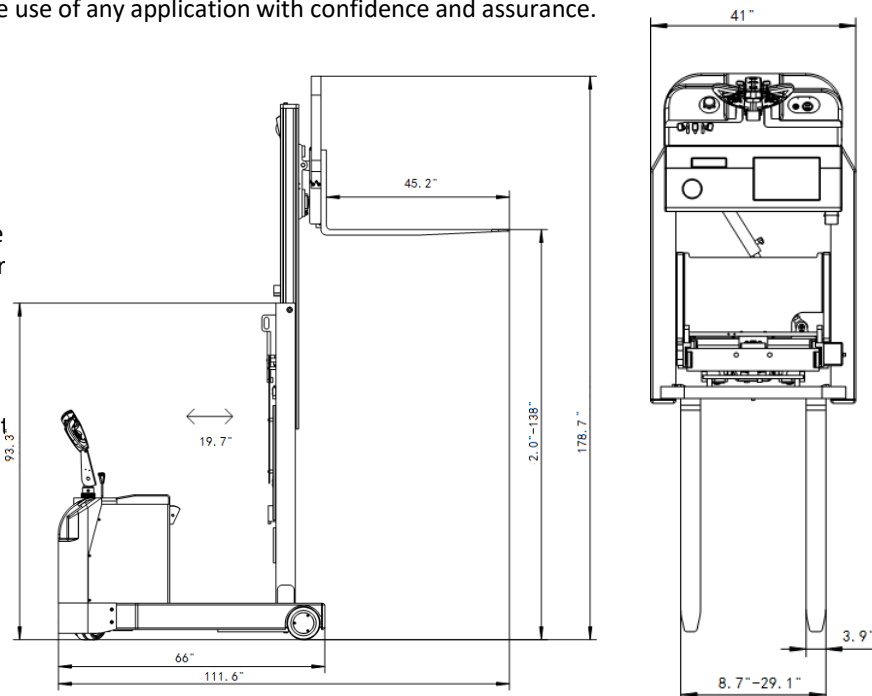

## EK18RRL Stand-up Rider Reach Truck

Model		EK18RRL
Lift		Electric
Drive		Electric
Load capacity	(lb.)	4000
Load center distance	(in)	24
Lifting height	(in)	196
Side Shifting Forks		3 Way Valve
Free Lift	(in)	53.15
Lowered mast height	(in)	96.42
Overall length/Extended	(in)	102.28
Overall width	(in)	54.72
Fork size, Thick/Width/Length	(in)	1.58/4.72/45
Fork adjust width	(in)	35.04
Reach Distance	(in)	22.44
Turning radius	(in)	75
Charger	(V/A)	48V/65A
Driving Motor	(V/W)	48V/6000
EPS Steering Motor	(V/W)	Yes
Lifting Motor	(V/W)	48V/11000
Battery voltage	(V/Ah)	48V/420Ah
Service Weight	(lb.)	9000



The EKKO EK18RRL Stand-Up Reach Truck is ideal and designed for narrow aisles with the combination of the versatility of a forklift, reach truck and a walkie stacker. It is ideal for loading and unloading trucks, loading docks, stock rooms, manufacturing floors and warehousing.

Made from high quality steel and components with durable quality drives to withstand any terrain, usage, impact and directional changes for the use of any application with confidence and assurance.

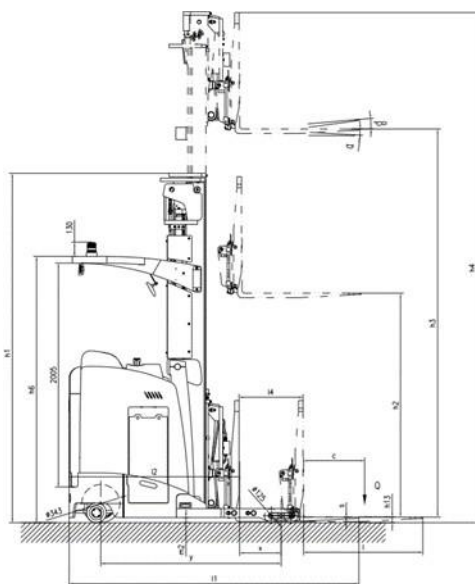

- Load Capacity 4000 lb.
- Side Shifting
- Raised Height 275" (14.75ft)
- Reach Distance of 19.7"
- Free Lift 63"
- Tilt 3/5 Degree
- Adjustable Forks 7.9-33"
- Fork Length 45.3"
- Curtis Instrument Controllers
- EPS (Electronic Power Steering)
- 48V German AC Drive Motor
- 48V Lift Motor
- Battery 48VV/420Ah
- Polyurethane Wheels
- Ergonomic Handle and Controls
- Steel Construction
- Robotic Welding
- Charger 48V/65A
- 3 Year Limited Warranty

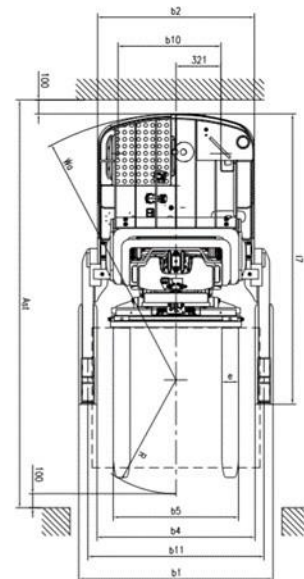

## EK18RR Stand-up Rider Reach Truck



Model		EK18RR
Lift		Electric
Drive		Electric
Load capacity	(lb.)	4000
Load center distance	(in)	24
Lifting height	(in)	275
Side Shifting Forks		3 Way Valve
Free Lift	(in)	79.92
Lowered mast height	(in)	123.27
Overall length/Extended	(in)	102.28
Overall width	(in)	54.72
Fork size, Thick/Width/Length	(in)	1.58/4.72/45
Fork adjust width	(in)	35.04
Reach Distance	(in)	22.44
Turning radius	(in)	75
Charger	(V/A)	48V/65A
Driving Motor	(V/W)	48V/6000
EPS Steering Motor	(V/W)	Yes
Lifting Motor	(V/W)	48V/11000
Battery voltage	(V/Ah)	48V/420Ah
Service Weight	(lb.)	9330

The EKKO EK18RR Stand-Up Reach Truck is ideal and designed for narrow aisles with the combination of the versatility of a forklift, reach truck and a walkie stacker. It is ideal for loading and unloading trucks, loading docks, stock rooms, manufacturing floors and warehousing.

Made from high quality steel and components with durable quality drives to withstand any terrain, usage, impact and directional changes for the use of any application with confidence and assurance.

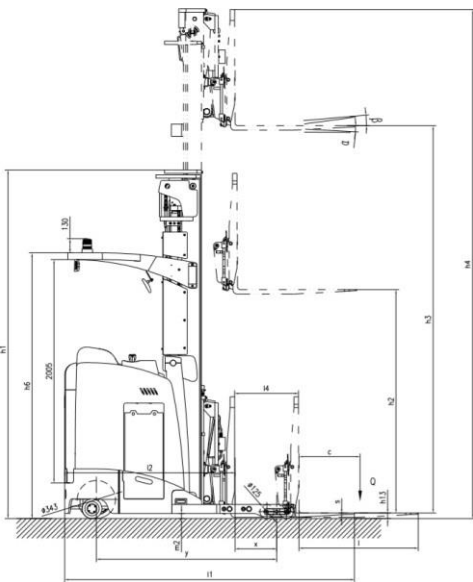

- Load Capacity 4000 lb.
- Side Shifting
- Raised Height 275" (14.75ft)
- Reach Distance of 19.7"
- Free Lift 63"
- Tilt 3/5 Degree
- Adjustable Forks 7.9-33"
- Fork Length 45.3"
- Curtis Instrument Controllers
- EPS (Electronic Power Steering)
- 48V German AC Drive Motor
- 48V Lift Motor
- Battery 48V/420Ah
- Polyurethane Wheels
- Ergonomic Handle and Controls
- Steel Construction
- Robotic Welding
- Charger 48V/65A
- 3 Year Limited Warranty

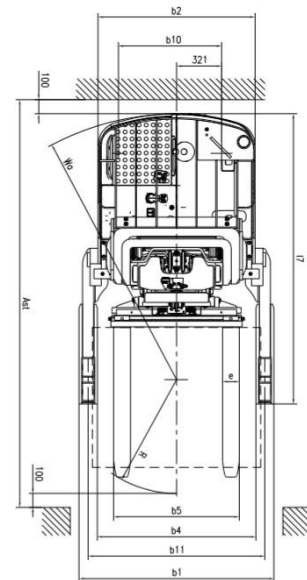



## EK18R-210LI Stand-up Rider Reach Truck

More information coming soon!!

**COMING SOON**

Model		EK18R-210LI
Lift		Electric
Drive		Electric
Load capacity	(lb.)	4000
Load center distance	(in)	24
Lifting height	(in)	210
Side Shifting Forks		3 Way Valve
Free Lift	(in)	
Lowered mast height	(in)	
Overall length/Extended	(in)	
Overall width	(in)	
Fork size, Thick/Width/Length	(in)	42
Fork adjust width	(in)	
Reach Distance	(in)	22.44
Turning radius	(in)	
Charger	(V/A)	
Driving Motor	(V/W)	AC Drive Motor
EPS Steering Motor	(V/W)	Yes
Lifting Motor	(V/W)	
Battery voltage	(V/Ah)	48V/404AH LI
Service Weight	(lb.)	9100



## EK18R-270LI Stand-up Rider Reach Truck

More  
information  
coming soon!!

**COMING  
SOON**

Model		EK18R-270LI
Lift		Electric
Drive		Electric
Load capacity	(lb.)	4000
Load center distance	(in)	24
Lifting height	(in)	270
Side Shifting Forks		3 Way Valve
Free Lift	(in)	
Lowered mast height	(in)	
Overall length/Extended	(in)	
Overall width	(in)	
Fork size, Thick/Width/Length	(in)	42
Fork adjust width	(in)	
Reach Distance	(in)	
Turning radius	(in)	
Charger	(V/A)	
Driving Motor	(V/W)	AC Drive Motor
EPS Steering Motor	(V/W)	Yes
Lifting Motor	(V/W)	
Battery voltage	(V/Ah)	48V/404AH LI
Service Weight	(lb.)	9300



## EK18R-300LI Stand-up Rider Reach Truck

More  
information  
coming soon!!

**COMING  
SOON**

Model		EK18R-300LI
Lift		Electric
Drive		Electric
Load capacity	(lb.)	4000
Load center distance	(in)	24
Lifting height	(in)	300
Side Shifting Forks		3 Way Valve
Free Lift	(in)	
Lowered mast height	(in)	
Overall length/Extended	(in)	
Overall width	(in)	
Fork size, Thick/Width/Length	(in)	42
Fork adjust width	(in)	
Reach Distance	(in)	22.44
Turning radius	(in)	
Charger	(V/A)	
Driving Motor	(V/W)	AC Drive Motor
EPS Steering Motor	(V/W)	Yes
Lifting Motor	(V/W)	
Battery voltage	(V/Ah)	48V/404AH LI
Service Weight	(lb.)	9500



## EK07S Counterbalance Walkie Stacker



Model		EK07S
Lift		Electric
Drive		Electric
Load capacity	(lb.)	1550
Load center distance	(in)	20
Lifting height	(in)	118
Lowered mast height	(in)	81.1
Overall length	(in)	84.7
Overall width	(in)	34.5
Fork size, Thick/Width/Length	(in)	1.4/2.9/42
Fork adjust width	(in)	8.3-25.2
Turning radius	(in)	51
Charger	(V/A)	24V/20A
Driving Motor	(V/W)	AC 24V/750W
Lifting Motor	(V/W)	24V/1500W
Battery voltage	(V/Ah)	24V/120Ah
Service Weight	(lb.)	2175

The EKKO EK07S Fully Powered Counterbalance Walkie Stacker is designed with the combination of the versatility of a forklift and a walkie stacker. It is ideal for loading and unloading trucks, loading docks, stock rooms, manufacturing floors and warehousing.

Made from high quality steel and components with durable quality drives to withstand any terrain, usage, impact and directional changes for the use of any application with confidence and assurance.

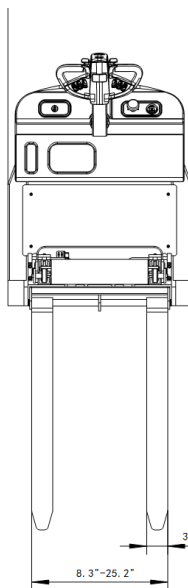

- Load Capacity 1550 lb.
- Raised Height 118" (9.83ft)
- Adjustable Forks 8.3-25.2"
  - Fork Length 42"
- Curtis Instrument Controller
  - 24V AC Drive Motor
  - 24V Lift Motor
- Polyurethane Wheels
- Ergonomic Handle and Controls
  - Steel Construction
  - Robotic Welding
- 3 Year Limited Warranty

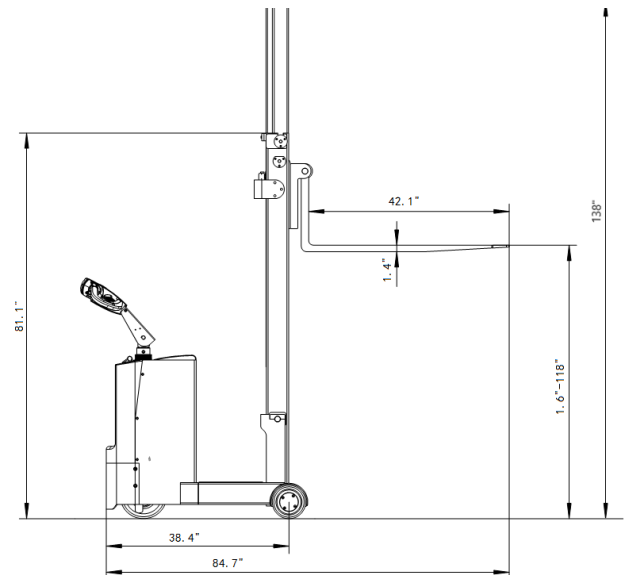

# EK13S-177 Counterbalance Stacker

The EKKO EK13S-177 Fully Powered Counterbalanced Walkie Stacker is designed with the combination of the versatility of a forklift and a walkie stacker. It is ideal for loading and unloading trucks, loading docks, stock rooms, manufacturing floors and warehousing.

Made from high quality steel and components with durable quality drives to withstand any

terrain, usage, impact and directional changes for the use of any application with confidence and assurance.

- Load Capacity 2860 lb.
- Raised Height 177" (14.75ft)
- Side Shift
- Adjustable Forks 8.6-28.3"
- Tilt 2/5 degree
- Fork Length 45.3"
- Curtis Instrument Controller
- EPS (Electronic Power Steering)
- 24V ZF AC Drive Motor
- 24V Lift Motor
- Polyurethane Wheels
- Ergonomic Handle and Controls
- Steel Construction
- Robotic Welding
- 3 Year Limited Warranty



Model	EK13S-177	
Lift		Electric
Drive		Electric
Load capacity	(lb.)	2860
Load center distance	(in)	24
Wheelbase	(in)	46.81
Lifting height	(in)	177
Side Shift		3 Way Valve
Lowered mast height	(in)	78.74
Extended mast height	(in)	214.53
Mast Carriage Tilt	( ° )	2/5
Overall length	(in)	107.8
Overall width	(in)	39
Fork size, Thick/Width/Length	(in)	1.4/4/45.3
Fork adjust width	(in)	8.6-28.3
Turning radius	(in)	56.89
Gradient performance, laden/unladen	(%)	6/8
Lift speed, laden/unladen	(in/s)	3.9/4.7
Lowering speed, laden/unladen	(in/s)	5.3/4.7
Charger	(V/A)	24V/30A
Driving Motor	(V/W)	AC 24V/2500W
Lifting Motor	(V/W)	24V/2500W
EPS Steering Motor	(V/W)	24/200W
Battery voltage	(V/Ah)	24V/210Ah (Side)
Service Weight	(lb.)	4070

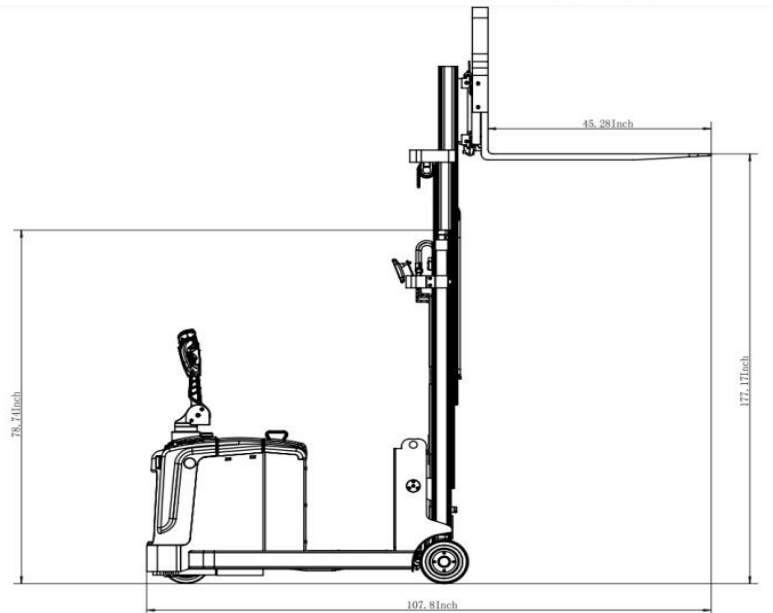

## EK14 Counterbalance Stacker

The EKKO EK14 Fully Powered Counterbalanced Walkie Stacker is designed with the combination of the versatility of a forklift and a walkie stacker. It is ideal for loading and unloading trucks, loading docks, stock rooms, manufacturing floors and warehousing.

Made from high quality steel and components with durable quality drives to withstand any terrain, usage, impact and directional changes for the use of any application with confidence and assurance.

- Load Capacity 3300 lbs.
- Raised Height 118" (9.83ft)
- Adjustable Forks 8.6-28.3"
- Fork Length 45.3"
- Tilt 2/5 Degree
- Curtis Controller
- 24V AC Drive Motor
- 24V Lift Motor
- EPS (Electronic Power Steering)
- Polyurethane Wheels
- Ergonomic Handle and Controls
- Steel Construction
- Robotic Welding
- Charger
- 3 Years Limited Warranty

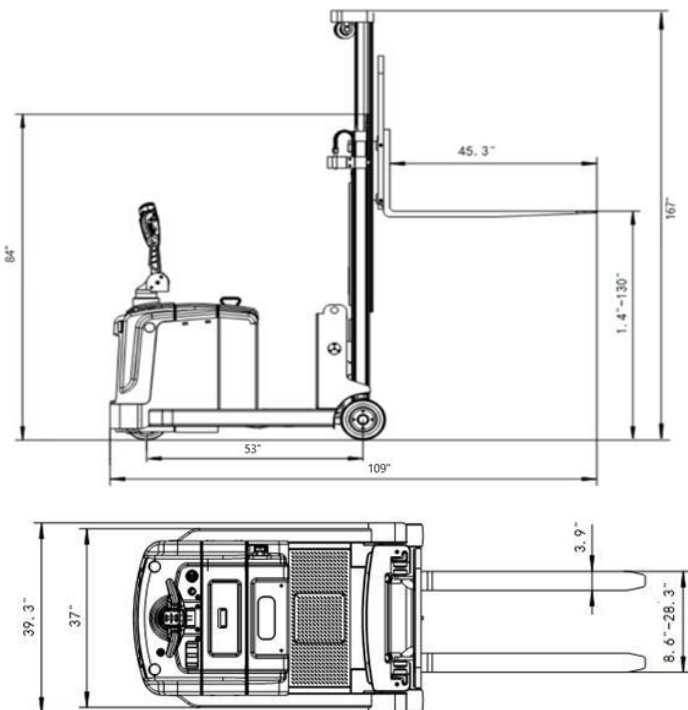

Model		EK14
Lift		Electric
Drive		Electric
Load capacity	(lb.)	3300
Load center distance	(in)	24
Wheelbase	(in)	47
Lifting height	(in)	118
Lowered mast height	(in)	78
Extended mast height	(in)	155
Mast/Fork carriage tilt forward/backward	( ° )	2/5
Overall length	(in)	109
Overall width	(in)	39
Fork size, Thick/Width/Length	(in)	1.4/4/45.3
Fork adjust width	(in)	8.6-28.3
Turning radius	(in)	57
Gradient laden/unladen	(%)	6/10
Lift speed, laden/unladen	(in/s)	4/5.1
Lowering speed, laden/unladen	(in/s)	5.3/4.7
Charger	(V/A)	24V/30A
Driving Motor	(V/W)	AC 24V/2500W
Lifting Motor	(V/W)	24V/2500W
EPS Steering Motor	(V/W)	24/200W
Battery voltage	(V/Ah)	24V/210Ah
Service Weight	(lb.)	3740

## EK14-130 Counterbalanced Stacker

The EKKO EK14-130 Fully Powered Counterbalanced Walkie Stacker is designed with the combination of the versatility of a forklift and a walkie stacker. It is ideal for loading and unloading trucks, loading docks, stock rooms, manufacturing floors and warehousing.

Made from high quality steel and components with durable quality drives to withstand any terrain, usage, impact and directional changes for the use of any application with confidence and assurance.

- Load Capacity 3300 lb.
- Raised Height 130" (10.8ft)
- Adjustable Forks 8.6-28.3"
- Tilt 2/5 degree
- Fork Length 45.3"
- Curtis Instrument Controller
- EPS (Electronic Power Steering)
- 24V ZF AC Drive Motor
- 24V Lift Motor
- Polyurethane Wheels
- Ergonomic Handle and Controls
- Steel Construction
- Robotic Welding
- 3 Year Limited Warranty



Model		EK14-130
Lift		Electric
Drive		Electric
Load capacity	(lb.)	3300
Load center distance	(in)	24
Wheelbase	(in)	47
Lifting height	(in)	130
Lowered mast height	(in)	84
Extended mast height	(in)	167
Mast Carriage Tilt	( ° )	2/5
Overall length	(in)	109
Overall width	(in)	39
Fork size, Thick/Width/Length	(in)	1.4/4/45.3
Fork adjust width	(in)	8.6-28.3
Turning radius	(in)	57
Gradient performance, laden/unladen	(%)	6/10
Lift speed, laden/unladen	(in/s)	4/5.1
Lowering speed, laden/unladen	(in/s)	5.3/4.7
Charger	(V/A)	24V/30A
Driving Motor	(V/W)	AC 24V/2500W
Lifting Motor	(V/W)	24V/2500W
EPS Steering Motor	(V/W)	24/200W
Battery voltage	(V/Ah)	24V/210Ah (Side)
Service Weight	(lb.)	3840

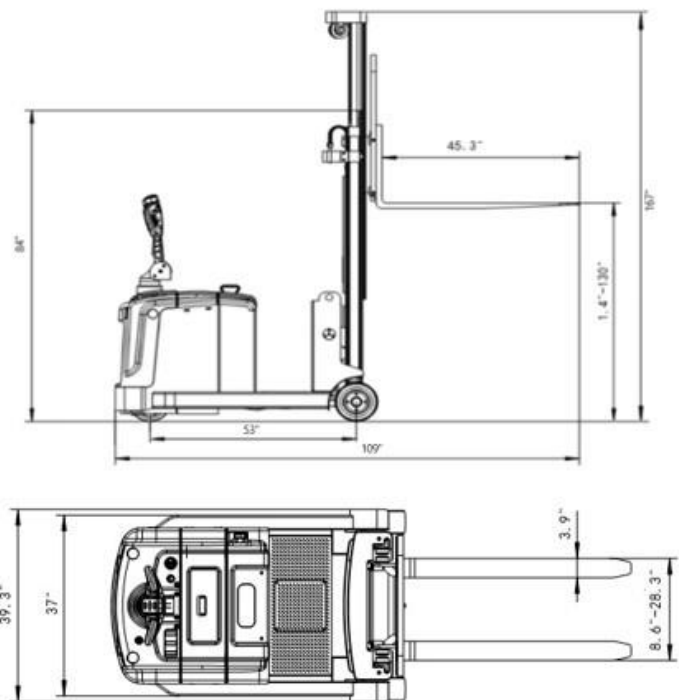

## EK14S-130 Counterbalanced Stacker

The EKKO EK14S-130 Fully Powered Counterbalanced Walkie Stacker is designed with the combination of the versatility of a forklift and a walkie stacker. It is ideal for loading and unloading trucks, loading docks, stock rooms, manufacturing floors and warehousing.

Made from high quality steel and components with durable quality drives to withstand any terrain, usage, impact and directional changes for the use of any application with confidence and assurance.

- Load Capacity 3300 lb.
- Raised Height 130" (10.8ft)
- **Side shift**
- Adjustable Forks 8.6-28.3"
- Tilt 2/5 degree
- Fork Length 45.3"
- Curtis Instrument Controller
- EPS (Electronic Power Steering)
- 24V ZF AC Drive Motor
- 24V Lift Motor
- Polyurethane Wheels
- Ergonomic Handle and Controls
- Steel Construction
- Robotic Welding
- 3 Year Limited Warranty



Model		EK14S-130
Lift		Electric
Drive		Electric
Load capacity	(lb.)	3300
Load center distance	(in)	24
Wheelbase	(in)	47
Lifting height	(in)	130
Side Shift		3 Way Valve
Lowered mast height	(in)	84
Extended mast height	(in)	167
Mast Carriage Tilt	(°)	2/5
Overall length	(in)	109
Overall width	(in)	39
Fork size, Thick/Width/Length	(in)	1.4/4/45.3
Fork adjust width	(in)	8.6-28.3
Turning radius	(in)	57
Gradient performance, laden/unladen	(%)	6/10
Lift speed, laden/unladen	(in/s)	4/5.1
Lowering speed, laden/unladen	(in/s)	5.3/4.7
Charger	(V/A)	24V/30A
Driving Motor	(V/W)	AC 24V/2500W
Lifting Motor	(V/W)	24V/2500W
EPS Steering Motor	(V/W)	24/200W
Battery voltage	(V/Ah)	24V/210Ah (Side)
Service Weight	(lb.)	3840

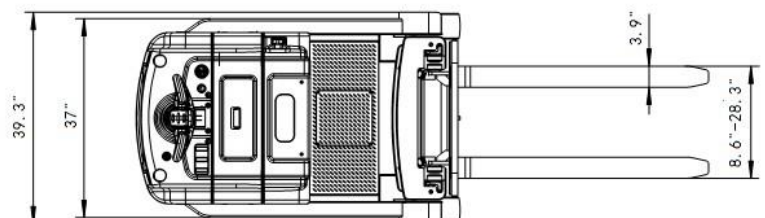
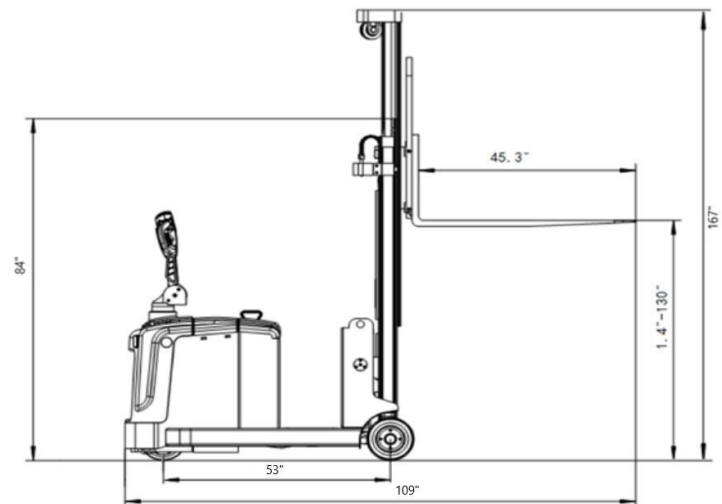



## EK14-138 Counterbalanced Stacker

The EKKO EK14-138 Fully Powered Counterbalanced Walkie Stacker is designed with the combination of the versatility of a forklift and a walkie stacker. It is ideal for loading and unloading trucks, loading docks, stock rooms, manufacturing floors and warehousing.

Made from high quality steel and components with durable quality drives to withstand any terrain, usage, impact and directional changes for the use of any application with confidence and assurance.

- Load Capacity 3300 lb.
- Raised Height 138"
- Adjustable Forks 8.6-28.3"
- Tilt 2/5 degree
- Fork Length 45.3"
- Curtis Instrument Controller
- EPS (Electronic Power Steering)
- 24V ZF AC Drive Motor
- 24V Lift Motor
- Polyurethane Wheels
- Ergonomic Handle and Controls
- Steel Construction
- Robotic Welding
- 3 Year Limited Warranty



Model		EK14-138
Lift		Electric
Drive		Electric
Load capacity	(lb.)	3300
Load center distance	(in)	24
Wheelbase	(in)	47
Lifting height	(in)	138
Lowered mast height	(in)	84
Extended mast height	(in)	167
Mast/Fork carriage tilt forward/backward	( ° )	2/5
Overall length	(in)	109
Overall width	(in)	39
Fork size, Thick/Width/Length	(in)	1.4/4/45.3
Fork adjust width	(in)	8.6-28.3
Turning radius	(in)	57
Gradient laden/unladen	(%)	6/10
Lift speed, laden/unladen	(in/s)	4/5.1
Lowering speed, laden/unladen	(in/s)	5.3/4.7
Charger	(V/A)	24V/30A
Driving Motor	(V/W)	AC 24V/2500W
Lifting Motor	(V/W)	24V/2500W
EPS Steering Motor	(V/W)	24/200W
Battery voltage	(V/Ah)	24V/210Ah
Service Weight	(lb.)	3840

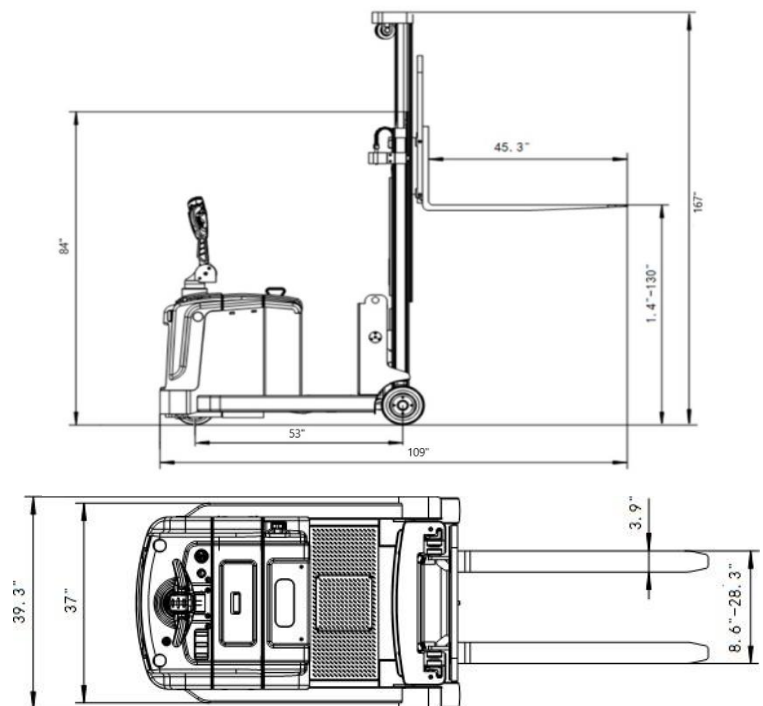

## EK14-189Li Counterbalanced Stacker

The EKKO EK14-189Li Fully Powered Counterbalanced Walkie Stacker is designed with the combination of the versatility of a forklift and a walkie stacker. It is ideal for loading and unloading trucks, loading docks, stock rooms, manufacturing floors and warehousing.

Made from high quality steel and components with durable quality drives to withstand any terrain, usage, impact and directional changes for the use of any application with confidence and assurance.

- Load Capacity 3300 lb.
- Raised Height 189"
- SIDE SHIFT
- Adjustable Forks 8.6-28.3"
- Tilt 2/5 degree
- Fork Length 45.3"
- Curtis Instrument Controller
- EPS (Electronic Power Steering)
- 24V ZF AC Drive Motor
- 24V Lift Motor
- Polyurethane Wheels
- Ergonomic Handle and Controls
- Steel Construction
- Robotic Welding
- 3 Year Limited Warranty



Model		EK14-189LI
Lift		Electric
Drive		Electric
Load capacity	(lb.)	3300
Load center distance	(in)	24
Wheelbase	(in)	47
Lifting height	(in)	189
Lowered mast height	(in)	84.5
Extended mast height	(in)	224
Mast/Fork carriage tilt forward/backward	( ° )	2/5
Overall length	(in)	109
Overall width	(in)	39
Fork size, Thick/Width/Length	(in)	1.4/4/45.3
Fork adjust width	(in)	8.6-28.3
Turning radius	(in)	57
Gradient laden/unladen	(%)	6/10
Lift speed, laden/unladen	(in/s)	4/5.1
Lowering speed, laden/unladen	(in/s)	5.3/4.7
Charger	(V/A)	24V/50A LI
Driving Motor	(V/W)	AC 24V/2500W
Lifting Motor	(V/W)	24V/2500W
EPS Steering Motor	(V/W)	24/200W
Battery voltage	(V/Ah)	24V/150Ah Lithium
Service Weight	(lb.)	4350

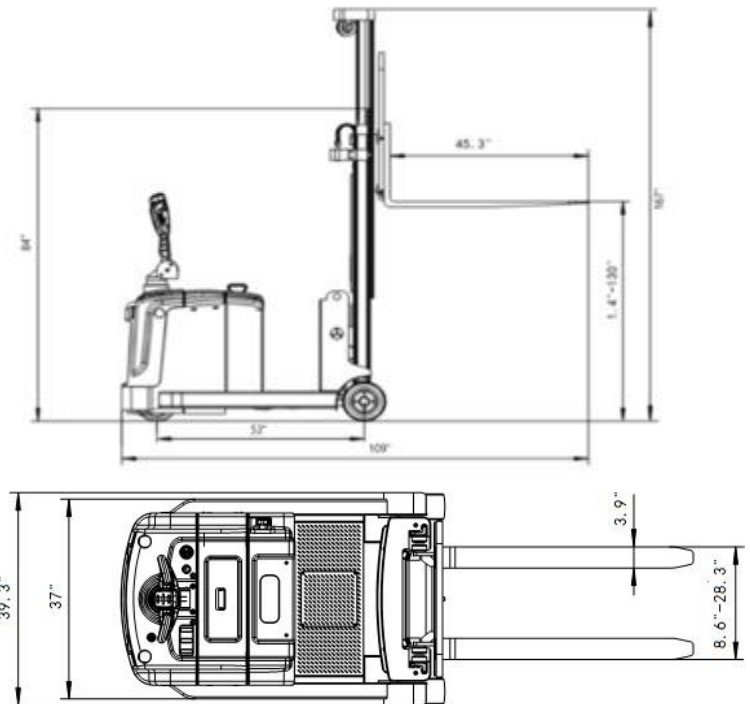

## EK14-130Li Counterbalanced Stacker

The EKKO EK14-189Li Fully Powered Counterbalanced Walkie Stacker is designed with the combination of the versatility of a forklift and a walkie stacker. It is ideal for loading and unloading trucks, loading docks, stock rooms, manufacturing floors and warehousing.

Made from high quality steel and components with durable quality drives to withstand any terrain, usage, impact and directional changes for the use of any application with confidence and assurance.

- Load Capacity 3300 lb.
- Raised Height 130"
- Adjustable Forks 8.6-28.3"
- Tilt 2/5 degree
- Fork Length 45.3"
- Curtis Instrument Controller
- EPS (Electronic Power Steering)
- 24V ZF AC Drive Motor
- 24V Lift Motor
- Polyurethane Wheels
- Ergonomic Handle and Controls
- Steel Construction
- Robotic Welding
- 3 Year Limited Warranty



Model		EK14-130LI
Lift		Electric
Drive		Electric
Load capacity	(lb.)	3300
Load center distance	(in)	24
Wheelbase	(in)	47
Lifting height	(in)	130
Lowered mast height	(in)	84.5
Extended mast height	(in)	224
Mast/Fork carriage tilt forward/backward	( ° )	2/5
Overall length	(in)	109
Overall width	(in)	39
Fork size, Thick/Width/Length	(in)	1.4/4/45.3
Fork adjust width	(in)	8.6-28.3
Turning radius	(in)	57
Gradient laden/unladen	(%)	6/10
Lift speed, laden/unladen	(in/s)	4/5.1
Lowering speed, laden/unladen	(in/s)	5.3/4.7
Charger	(V/A)	24V/50A LI
Driving Motor	(V/W)	AC 24V/2500W
Lifting Motor	(V/W)	24V/2500W
EPS Steering Motor	(V/W)	24/200W
Battery voltage	(V/Ah)	24V/150Ah Lithium
Service Weight	(lb.)	4350

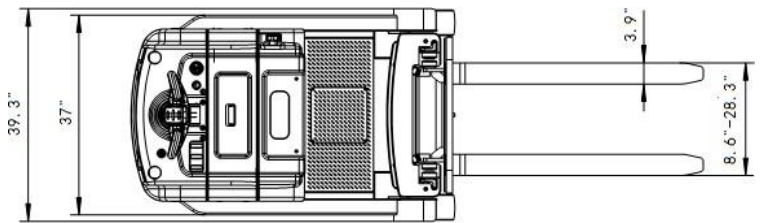
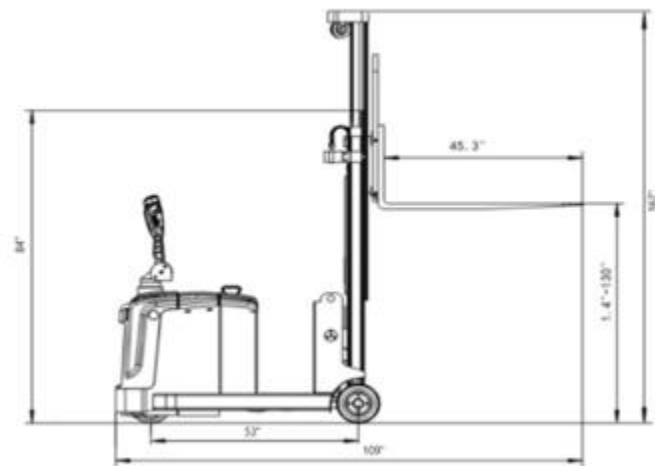

## EOP68 Order Picker



Model		EOP68
Lift		Electric
Drive		Electric
Load capacity	(lb.)	2200
Load center distance	(in)	20
Lifting height	(in)	177
Lowered mast height	(in)	98.03
Overall length	(in)	111.41
Overall width	(in)	39.37
Fork size, Thick/Width/Length	(in)	1.4/3.93/42
Fork Length	(in)	42.13
Turning radius	(in)	61.81
Charger	(V/A)	24V/5A
Driving Motor	(V/W)	AC 24V/ 3000W
Lifting Motor	(kw)	6
Battery voltage	(V/Ah)	24V/280Ah

The EKKO EOP68 Electric Mid-Level Order Picker is designed with the sole purpose to pick your orders, whether it is in your racking rooms, storage facility rooms, manufacturing floors or warehousing.

Made from high quality steel and components with durable quality drives to withstand any terrain, usage, impact, or directional changes ensuring the use of any application with confidence and assurance.

- Load Capacity 2200 lb.
- Raised Height 177" (14.75 ft.)
- Adjustable Forks
- Auxiliary Fork
- Triple Mast
- Curtis Instrument Controller
- EPS (Electronic Power Steering)
- German AC Drive Motor
- Battery 24V/280Ah
- 24V/50A
- Polyurethane Wheels
- Ergonomic Handle and Controls
- Steel Construction
- Robotic Welding
- Charger Included
- Battery Included
- 3 Years Limited Warranty

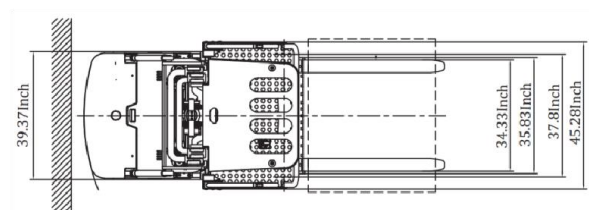
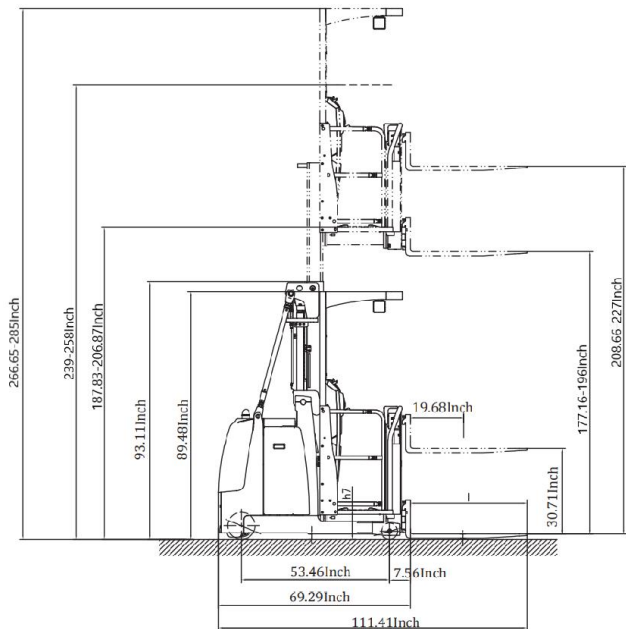

## EOP70 Order Picker

The EKKO EOP70 Electric Mid-Level Order Picker is designed with the sole purpose to pick your orders, whether it is in your racking rooms, storage facility rooms, manufacturing floors or warehousing.

Made from high quality steel and components with durable quality drives to withstand any terrain, usage, impact, or directional changes ensuring the use of any application with confidence and assurance

- Load Capacity 2200 lbs.
- Raised Height 196" (16.33 ft.)
- Adjustable Forks
- Auxiliary Fork
- Triple Mast
- Curtis Instrument Controller
- EPS (Electronic Power Steering)
- German AC Drive Motor
- Battery 24V/280Ah
- 24V/50A
- Polyurethane Wheels
- Ergonomic Handle and Controls
- Steel Construction
- Robotic Welding
- Charger Included
- Battery Included
- 3 Years Limited Warranty

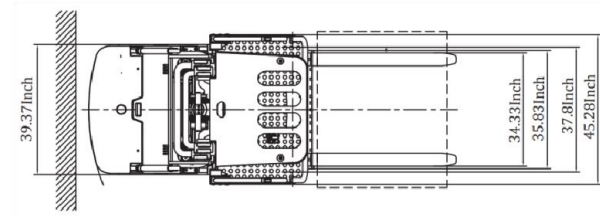
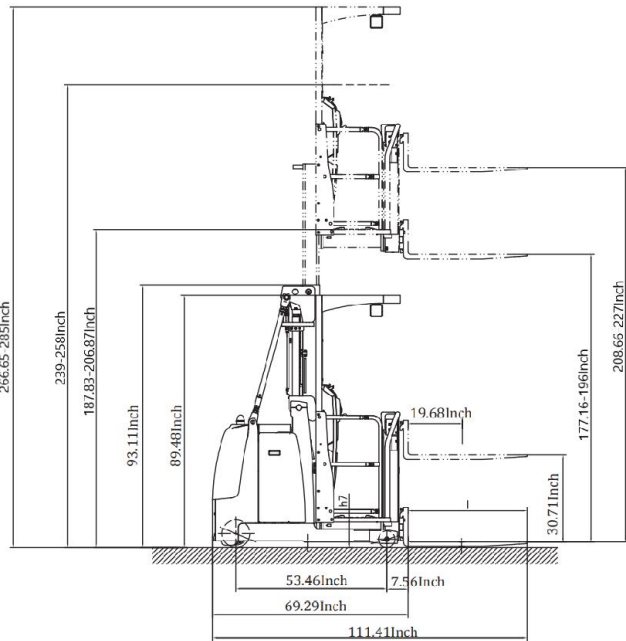

Model		EOP70
Lift		Electric
Drive		Electric
Load capacity	(lb.)	2200
Load center distance	(in)	20
Lifting height	(in)	196
Lowered mast height	(in)	98.03
Overall length	(in)	111.41
Overall width	(in)	39.37
Fork size, Thick/Width/Length	(in)	1.4/3.93/42
Fork Length	(in)	42.13
Turning radius	(in)	61.81
Charger	(V/A)	24V/5A
Driving Motor	(V/W)	AC 24V/ 3000W
Lifting Motor	(kw)	6
Battery voltage	(V/Ah)	24V/280Ah

## EOP70LI Order Picker

The EKKO EOP70LI Electric Mid-Level Order Picker is designed with the sole purpose to pick your orders, whether it is in your racking rooms, storage facility rooms, manufacturing floors or warehousing.

Made from high quality steel and components with durable quality drives to withstand any terrain, usage, impact, or directional changes ensuring the use of any application with confidence and assurance

- Load Capacity 2200 lbs.
- Raised Height 196" (16.33 ft.)
- Adjustable Forks
- Auxiliary Fork
- Triple Mast
- Curtis Instrument Controller
- EPS (Electronic Power Steering)
- German AC Drive Motor
- Battery 24V/350AH Lithium
- 24V/50A Lithium
- Polyurethane Wheels
- Ergonomic Handle and Controls
- Steel Construction
- Robotic Welding
- Charger Included
- Battery Included
- 3 Years Limited Warranty



Model		EOP70LI
Lift		Electric
Drive		Electric
Load capacity	(lb.)	2200
Load center distance	(in)	20
Lifting height	(in)	196
Lowered mast height	(in)	98.03
Overall length	(in)	111.41
Overall width	(in)	39.37
Fork size, Thick/Width/Length	(in)	1.4/3.93/42
Fork Length	(in)	42.13
Turning radius	(in)	61.81
Charger	(V/A)	24V/5A
Driving Motor	(V/W)	AC 24V/ 3000W
Lifting Motor	(kw)	6
Battery voltage	(V/Ah)	24V/350AH LI

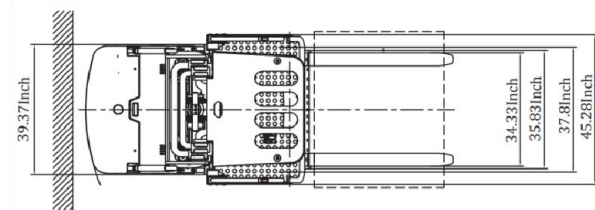
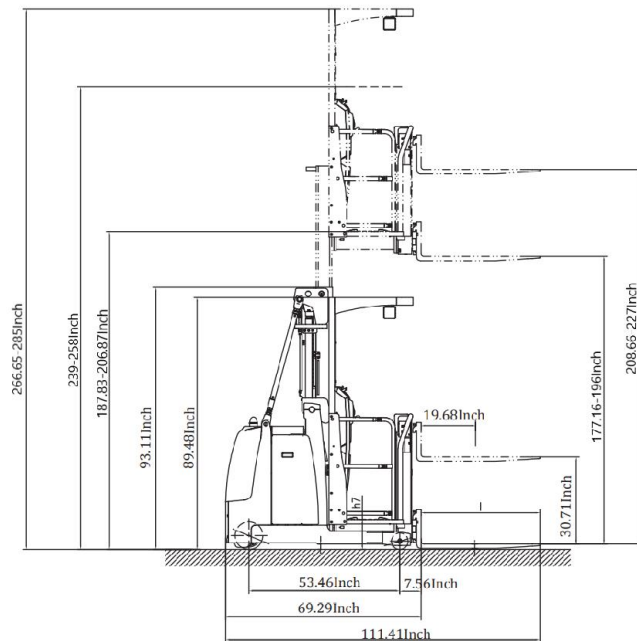

## EA15B Semi-Electric Straddle Stacker



Model		EA15B
Load Capacity	(lb.)	3300
Lifting height Max.	(in)	119.4
Load center distance	(in)	24
Fork length	(in)	45.3
Single fork width	(in)	3.9
Overall fork width	(in)	8-33.4
Lowered fork height	(in)	2.4
Fixed leg length	(in)	34
Fixed leg width, single	(in)	3.9
Adjustable legs	(in)	43.5-59.1
Turning radius	(in)	53.2
Overall length	(in)	73
Overall width max	(in)	59
Extended mast height	(in)	140.5
Lowered mast height	(in)	84.5
Battery Voltage	(V/Ah)	12V/120Ah
Charger	(V/A)	12V/15A
Lift Motor	(V/W)	DC 12V/1500W
Service Weight	(lb.)	1200

The EKKO EA15B Semi-Electric Straddle Stacker is designed with the combination of the versatility of a forklift and a pallet stacker. It is ideal for loading and unloading trucks, loading docks, stock rooms, manufacturing floors and warehousing.

Made from high quality steel and components with durable quality drives to withstand any terrain, usage, impact and directional changes for the use of any application with confidence and assurance.

- Load Capacity 3300 lb.
- Raised Height 119.4" (9.95ft)
- Adjustable Forks 8.3-33.4"
- Adjustable Legs 43.5-59.1"
- Power Lifting
- Manual Drive
- External Charger 12V/15Ah
- Battery 12V/120Ah
- Ergonomic Handle
- Steel Construction
- Robotic Welding
- 3 Year Limited Warranty

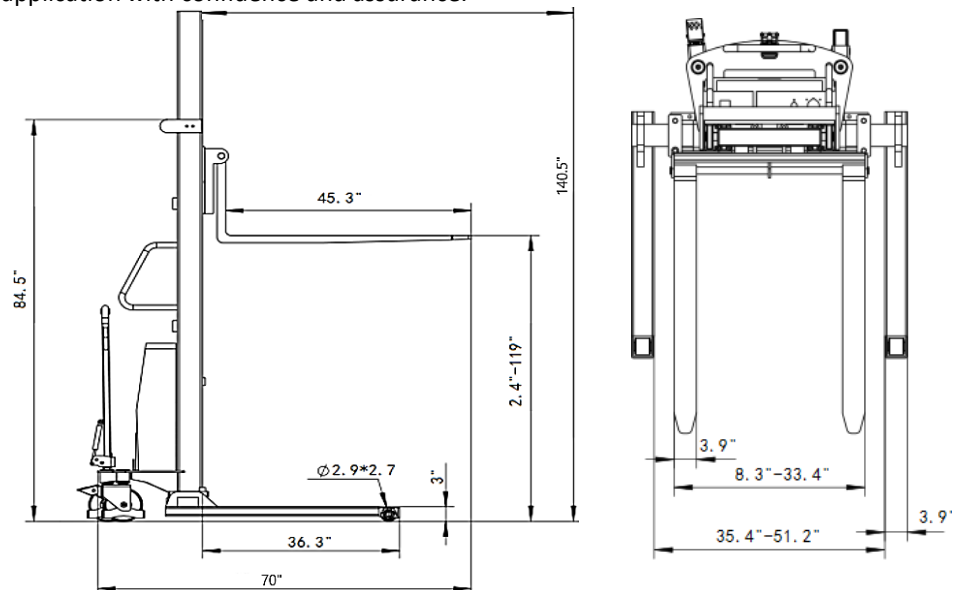

## EA15D Semi-Electric Straddle Stacker

The EKKO EA15D Semi-Electric Straddle Stacker is designed with the combination of the versatility of a forklift and a pallet stacker. It is ideal for loading and unloading trucks, loading docks, stock rooms, manufacturing floors and warehousing.

Made from high quality steel and components with durable quality drives to withstand any terrain, usage, impact and directional changes for the use of any application with confidence and assurance.

- Load Capacity 3300lbs.
- Raised Height 138" (11.5ft)
- Adjustable Forks 8.3-33.5"
- Adjustable Legs 43.5-59.1"
- Fork Length 45.3"
- Power Lifting
- Manual Drive
- Adjustable Forks
- Built-in Charger 12v 120Ah
- Batteries Included
- Ergonomic Handle
- Steel Construction
- Robotic Welding
- 3 Years Limited Warranty

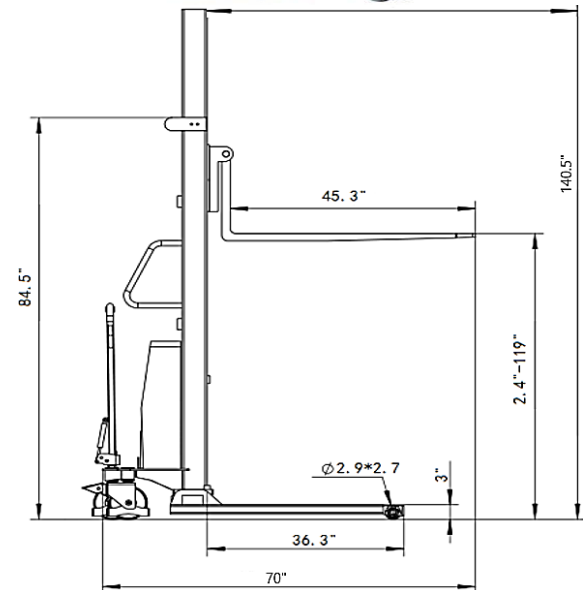

Model		EA15D
Load Capacity	(lb.)	3300
Lifting height Max.	(in)	138
Load center distance	(in)	24
Fork length	(in)	45.3
Single fork width	(in)	4
Overall fork width	(in)	8-32.7
Lowered fork height	(in)	2.35
Fixed leg length	(in)	36.5
Fixed leg width, single	(in)	3.94
Adjustable legs	(in)	44.5-59.1
Turning radius	(in)	52.6
Overall length	(in)	70
Overall width max	(in)	61
Extended mast height	(in)	154
Lowered mast height	(in)	84.5
Battery Voltage	(V/Ah)	12V/120Ah
Charger	(V/A)	12V/15A
Lift Motor	(V/W)	DC 12V/1500W
Service Weight	(lb.)	1450



## EA15C Semi-Electric Fork-Over Stacker



Model		EA15C
Load Capacity	(lb.)	3300
Lifting height Max.	(in)	119.4
Load center distance	(in)	24
Fork length	(in)	45.3
Single fork width	(in)	5.9
Overall fork width	(in)	24.5
Lowered fork height	(in)	2.4
Fixed leg length	(in)	45.3
Fixed leg width, single	(in)	5.9
Width between legs	(in)	23.2
Turning radius	(in)	53.2
Overall length	(in)	73
Overall width max	(in)	59
Extended mast height	(in)	140.5
Lowered mast height	(in)	81.8
Battery Voltage	(V/Ah)	12V/120Ah
Charger	(V/A)	12V/20A
Lift Motor	(V/W)	DC 12V/1500W
Service Weight	(lb.)	870

The EKKO EA15C Semi-Electric Fork-over Stacker is designed with the combination of the versatility of a forklift and a pallet stacker. It is ideal for loading and unloading trucks, loading docks, stock rooms, manufacturing floors and warehousing.

Made from high quality steel and components with durable quality drives to withstand any terrain, usage, impact and directional changes for the use of any application with confidence and assurance.

- Load Capacity 3300 lb.
- Raised Height 119.4" (9.95ft)
- Fork Width between Legs 12.75
- Power Lifting
- Manual Drive
- Internal Charger 12V/20Ah
- Battery 12V/120Ah
- Ergonomic Handle
- Steel Construction
- Robotic Welding
- 3 Year Limited Warranty

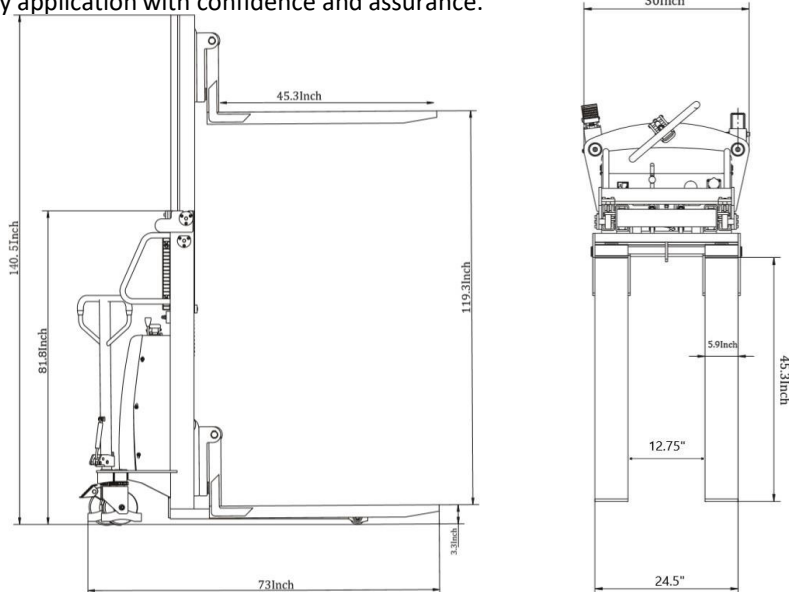

## EB12E Full Powered Walkie Stacker

The EKKO EB12E Electric Straddle Stacker is designed with the combination of the versatility of forklift, reach truck and a walkie stacker. It is ideal for loading and unloading trucks, loading docks, stock rooms, manufacturing floors and warehousing.

Made from high quality steel and components with durable quality drives to withstand any terrain, usage, impact and directional changes for the use of any application with confidence and assurance.

- Load Capacity 2640lbs.
- Raised Height 119.4"
- Adjustable Forks 8.3-33.5"
- Adjustable Legs 45.7-59.1"
- Fork Length 45.3"
- Curtis Instrument Controller
- 24V Drive Motor
- 24V Lift Motor
- Battery 2\*12V/100Ah
- Polyurethane Wheels
- Ergonomic Handle and Controls
- Steel Construction
- Robotic Welding
- 3 Year Limited Warranty

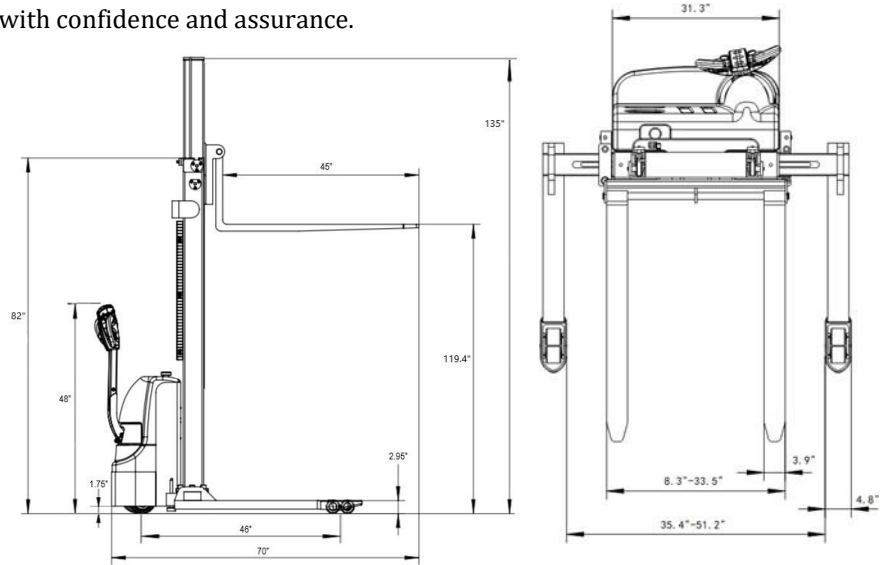

Model		EB12E
Load capacity	(lbs.)	2640
The max. lifting height	(in)	119.4"
Load center distance	(in)	24
Fork length	(in)	45.3
Single fork width	(in)	4
Overall fork width	(in)	8.3-33.5
Lowered fork height	(in)	2.35
Fixed leg length	(in)	36.5
Adjustable legs	(in)	45.5-59.1
Turning radius	(in)	52.6
Overall length	(in)	70
Max Overall width	(in)	61
Extended mast height	(in)	135
Lowered mast height	(in)	82
Battery voltage (dimensions)	(in)	2×12V/100AH (10/6.6/8.5)
Internal Charger	V/A	24V/15A
Lifting Motor	V/Kw	2.2kw. Lift speed, laden/unladen:92/136mm/s Lowering speed, laden/unladen:112/98mm/s
Driving Motor		0.75kw. Driving speed: laden/unladen:4.0/4.2km/h
Service Weight	(lbs.)	1420



## EB12E-138 Full Powered Walkie Stacker

The EKKO EB12E-138 Electric Straddle Stacker is designed with the combination of the versatility of forklift, reach truck and a walkie stacker. It is ideal for loading and unloading trucks, loading docks, stock rooms, manufacturing floors and warehousing.

Made from high quality steel and components with durable quality drives to withstand any terrain, usage, impact and directional changes for the use of any application with confidence and assurance.

- Load Capacity 2640 lb.
- Raised Height 138"
- Adjustable Forks 8.3-33.5"
- Adjustable Legs 45.7-59.1"
- Fork Length 45.3"
- Curtis Instrument Controller
- 24V Drive Motor
- 24V Lift Motor
- Battery 2\*12V/100Ah
- Polyurethane Wheels
- Ergonomic Handle and Controls
- Steel Construction
- Robotic Welding
- 3 Year Limited Warranty

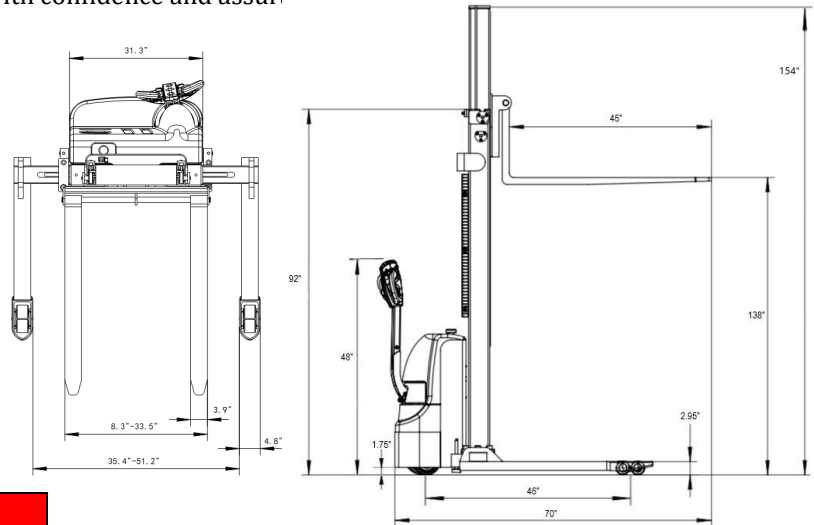

Model		EB12E-138
Load capacity	(lb.)	2640
The max. lifting height	(in)	138"
Load center distance	(in)	24
Fork length	(in)	45.3
Single fork width	(in)	4
Overall fork width	(in)	8.3-33.5
Lowered fork height	(in)	2.35
Fixed leg length	(in)	36.5
Adjustable legs	(in)	45.5-59.1
Turning radius	(in)	52.6
Overall length	(in)	70
Max Overall width	(in)	61
Extended mast height	(in)	154
Lowered mast height	(in)	92
Battery voltage (dimensions)	(in)	2 × 12V/100AH (10/6.6/8.5)
Internal Charger	(V/A)	24V/15A
Lifting Motor	(V/W)	2.2kw. Lift speed, laden/unladen:92/136mm/s Lowering speed, laden/unladen:112/98mm/s
Driving Motor	(W)	0.75kw. Driving speed: laden/unladen:4.0/4.2km/h
Service Weight	(lb.)	1450



# EB12EA Full Powered Walkie Stacker

The EKKO EB12EA Electric Straddle Stacker is designed with the combination of the versatility of forklift, reach truck and a walkie stacker. It is ideal for loading and unloading trucks, loading docks, stock rooms, manufacturing floors and warehousing.

Made from high quality steel and components with durable quality drives to withstand any terrain, usage, impact and directional changes for the use of any application with confidence and assurance.

- Load Capacity 3000 lb.
- Raised Height 145.67"
- Adjustable Forks 8.3-33.5"
- Adjustable Legs 45.7-59.1"
- Fork Length 45.3"
- Curtis Instrument Controller
- 24V Lift Motor
- Battery 2\*12V/120Ah
- Polyurethane Wheels
- Ergonomic Handle and Controls
- Steel Construction
- Robotic Welding
- 3 Year Limited Warranty

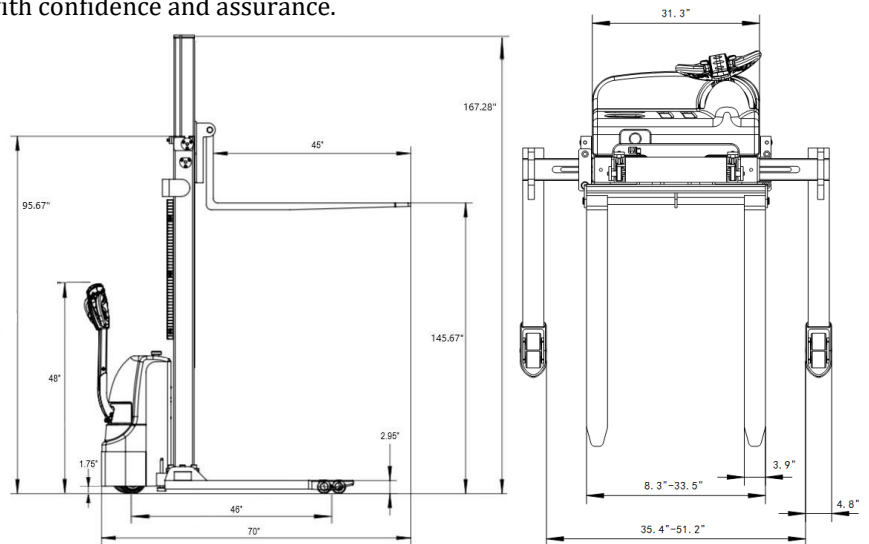

Model		EB12EA
Load capacity	(lb.)	3000
The max. lifting height	(in)	145.67"
Load center distance	(in)	24
Fork length	(in)	45.3
Single fork width	(in)	4
Overall fork width	(in)	8.3-33.5
Lowered fork height	(in)	2.35
Fixed leg length	(in)	36.5
Adjustable legs	(in)	45.5-59.1
Turning radius	(in)	52.6
Overall length	(in)	70
Max Overall width	(in)	61
Extended mast height	(in)	167.28
Lowered mast height	(in)	95.67
Battery voltage (dimensions)	(in)	2 × 12V/120AH ( 10/6.6/8.5 )
Internal Charger	(V/A)	24V/15A
Lifting Motor	(V/W)	2200-Watt, Lift speed, laden/unladen:92/136mm/s Lowering speed, laden/unladen:112/98mm/s
Driving Motor	(W)	1500 Watt, Driving speed: laden/unladen: 4.0/4.2km/h
Service Weight	(lb.)	1584



## EB13E Full Powered Walkie Stacker

The EKKO EB13E Electric Straddle Stacker is designed with the combination of the versatility of a forklift, reach truck and a walkie stacker. It is ideal for loading and unloading trucks, loading docks, stock rooms, manufacturing floors and warehousing.

Made from high quality steel and components with durable quality drives to withstand any terrain, usage, impact and directional changes for the use of any application with confidence and assurance.

- Load Capacity 2800 lb.
- Raised Height 119"
- Adjustable Forks 8.3-33.5"
- Adjustable Legs 45.7-59.1"
- Fork Length 45.3"
- Curtis Instrument Controller
- 24V Lift Motor
- Battery 2\*12V/100Ah
- Polyurethane Wheels
- Ergonomic Handle and Controls
- Steel Construction
- Robotic Welding
- 3 Year Limited Warranty

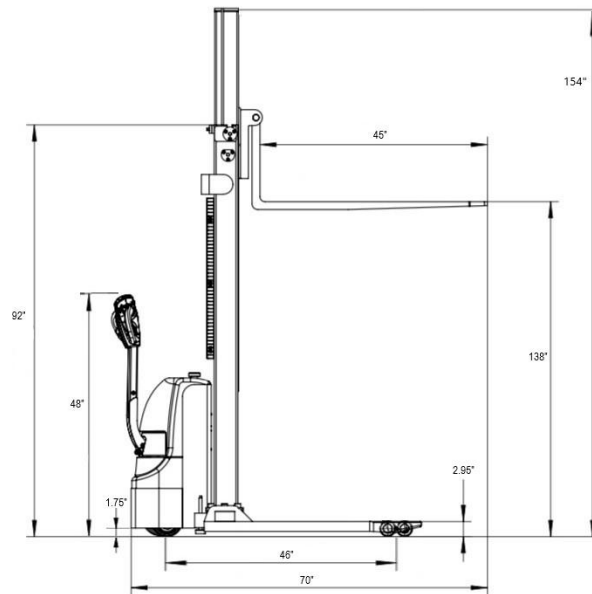

Model		EB13E
Load capacity	(lb.)	2800
The max. lifting height	(in)	119"
Load center distance	(in)	24
Fork length	(in)	45.3
Single fork width	(in)	4
Overall fork width	(in)	8.3-33.5
Lowered fork height	(in)	2.35
Fixed leg length	(in)	36.5
Adjustable legs	(in)	45.5-59.1
Turning radius	(in)	52.6
Overall length	(in)	70
Max Overall width	(in)	61
Extended mast height	(in)	135
Lowered mast height	(in)	82
Battery voltage (dimensions)	(in)	2 × 12V/100AH (10/6.6/8.5)
Internal Charger	(V/A)	24V/15A
Lifting Motor	(V/W)	2000-Watt, Lift speed, laden/unladen:92/136mm/s Lowering speed, laden/unladen:112/98mm/s
Driving Motor	(W)	750 Watt, Driving speed: laden/unladen:4.0/4.2km/h
Service Weight	(lb.)	1450

# EB13E-138 Full Powered Walkie Stacker

The EKKO EB13E-138 Electric Straddle Stacker is designed with the combination of the versatility of a forklift, reach truck and a walkie stacker. It is ideal for loading and unloading trucks, loading docks, stock rooms, manufacturing floors and warehousing.

Made from high quality steel and components with durable quality drives to withstand any terrain, usage, impact and directional changes for the use of any application with confidence and assurance.

- Load Capacity 2800 lb.
- Raised Height 138"
- Adjustable Forks 8.3-33.5"
- Adjustable Legs 45.7-59.1"
- Fork Length 45.3"
- Curtis Instrument Controller
- 24V Lift Motor
- Battery 2\*12V/100Ah
- Polyurethane Wheels
- Ergonomic Handle and Controls
- Steel Construction
- Robotic Welding
- 3 Year Limited Warranty

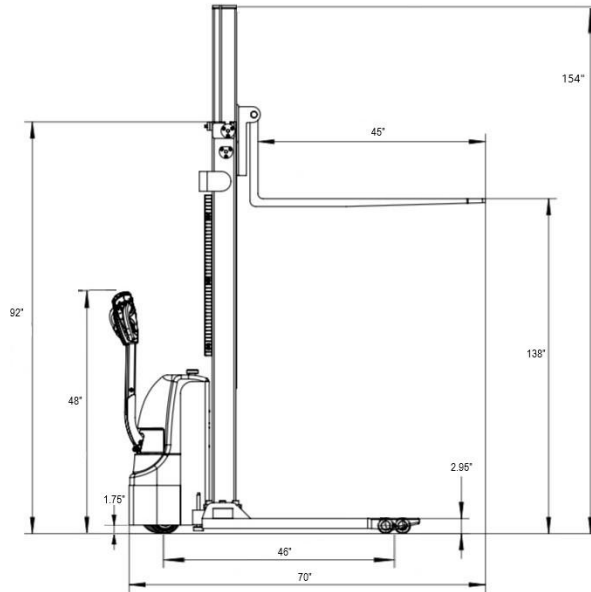

Model		EB13E-138
Load capacity	(lb.)	2800
The max. lifting height	(in)	138"
Load center distance	(in)	24
Fork length	(in)	45.3
Single fork width	(in)	4
Overall fork width	(in)	8.3-33.5
Lowered fork height	(in)	2.35
Fixed leg length	(in)	36.5
Adjustable legs	(in)	45.5-59.1
Turning radius	(in)	52.6
Overall length	(in)	70
Max Overall width	(in)	61
Extended mast height	(in)	154
Lowered mast height	(in)	92
Battery voltage (dimensions)	(in)	2 × 12V/100AH (10/6.6/8.5)
Internal Charger	(V/A)	24V/15A
Lifting Motor	(V/W)	2000-Watt, Lift speed, laden/unladen:92/136mm/s Lowering speed, laden/unladen:112/98mm/s
Driving Motor	(W)	750 Watt, Driving speed: laden/unladen:4.0/4.2km/h
Service Weight	(lb.)	1450



# EB18E Full Powered Walkie Stacker



The EKKO EB18E Electric Straddle Stacker is designed with the combination of the versatility of a forklift, reach truck and a walkie stacker. It is ideal for loading and unloading trucks, loading docks, stock rooms, manufacturing floors and warehousing.

Made from high quality steel and components with durable quality drives to withstand any terrain, usage, impact and directional changes for the use of any application with confidence and assurance.

- Load Capacity 4000 lb.
- Raised Height 138"
- Adjustable Forks 9.8-31.5"
- Adjustable Legs 45.5-59.1"
- Fork Length 45.3"
- Curtis Instrument Controller
- 24V AC Drive Motor
- 24V Lift Motor
- Battery 24V/160Ah
- Polyurethane Wheels
- Ergonomic Handle and Controls
- Steel Construction
- Robotic Welding

Model		EB18E
Load capacity	(lb.)	4000
The max. lifting height	(in)	138
Load center distance	(in)	24
Fork length	(in)	45.3
Single fork width	(in)	4.7
Overall fork width	(in)	9.8-31.5
Lowered fork height	(in)	2.35
Fixed leg length	(in)	36.5
Adjustable legs	(in)	45.5-59.1
Turning radius	(in)	60
Overall length	(in)	82
Max width	(in)	61
Extended mast height	(in)	154
Lowered mast height	(in)	91.3
Battery voltage	(V/Ah)	2x12V/160Ah
The charger	(V/A)	24V/20A
Lifting Motor	(W)	3000-Watt, Lift speed, laden/unladen:92/136mm/s Lowering speed, laden/unladen:112/98mm/s
Driving Motor	(W)	1500 Watt, Driving speed: laden/unladen:4.0/4.2km/h
Service Weight	(lb.)	2100

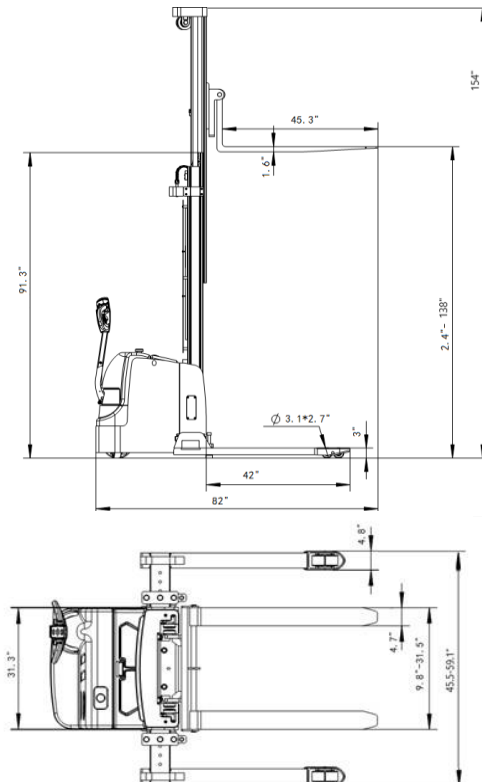

## EB20E Full Powered Walkie Stacker

The EKKO EB20E Electric Straddle Stacker is designed with the combination of the versatility of a forklift, reach truck and a walkie stacker. It is ideal for loading and unloading trucks, loading docks, stock rooms, manufacturing floors and warehousing.

Made from high quality steel and components with durable quality drives to withstand any terrain, usage, impact and directional changes for the use of any application with confidence and assurance.

- Load Capacity 4400 lb.
- Raised Height 177"
- Adjustable Forks 9.8-31.5"
- Adjustable Legs 45.5-59.1"
- Fork Length 45.3"
- Curtis Instrument Controller
- 24V AC Drive Motor
- 24V Lift Motor
- Triple Mast
- Battery 24V/210Ah
- Polyurethane Wheels
- Ergonomic Handle and Controls
- Steel Construction
- Robotic Welding
- 3 Year Limited Warranty



Model		EB20E
Load capacity	(lb.)	4400
The max. lifting height	(in)	177
Load center distance	(in)	24
Fork length	(in)	45.3
Single fork width	(in)	4.7
Overall fork width	(in)	9.8-31.5
Lowered fork height	(in)	3
Fixed leg length	(in)	42
Adjustable legs	(in)	45.5-59.1
Turning radius	(in)	60
Overall length	(in)	85
Max width	(in)	61
Extended mast height	(in)	198
Lowered mast height	(in)	85
Battery voltage	(V/Ah)	24/210Ah
The charger	(V/A)	24V/30A
Lifting Motor	(V/W)	3000W, Lift speed, laden/unladen:92/136mm/s Lowering speed, laden/unladen:112/98mm/s
Driving Motor	(W)	1500W, Driving speed: laden/unladen:4.0/4.2km/h
Service Weight	(lb.)	2800

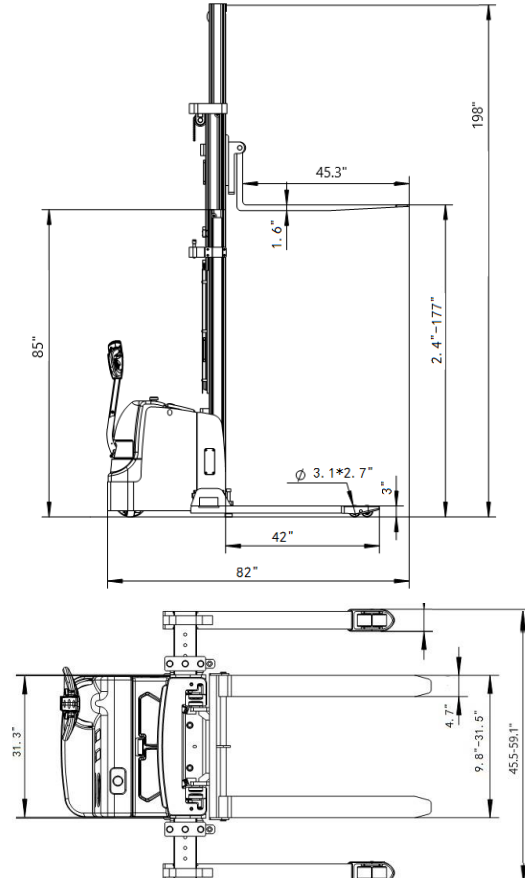



## EB16EA Full Powered Walkie Stacker

The EKKO EB16EA Electric Straddle Stacker is designed with the combination of the versatility of a forklift, walkie stacker. It is ideal for loading and unloading trucks, loading docks, stock rooms, manufacturing floors and warehousing.

Made from high quality steel and components with durable quality drives to withstand any terrain, usage, impact and directional changes for the use of any application with confidence and assurance.

- Load Capacity 4400 lb.
- Raised Height 216"
- Adjustable Forks 9.8-31.5"
- Adjustable Legs 38.06-51.8"
- Fork Length 45.28"
- Free Lift 76.25"
- EPS (Electric Power Steering)
- Curtis Instrument Controller
- 24V Center AC Drive Motor
- 24V Lift Motor
- Triple Mast
- Battery 24V/210Ah
- Polyurethane Wheels
- Ergonomic Handle and Controls
- Steel Construction
- Robotic Welding
- 3 Year Limited Warranty



Model		EB16EA
Load capacity	(lb.)	4400
The max. lifting height	(in)	216
Load center distance	(in)	24
Free Lift	(in)	76.25
EPS (Elec. Power Steer)		Yes
Fork length	(in)	45.28
Single fork width	(in)	4.7
Overall fork width	(in)	9.8-31.5
Lowered fork height	(in)	1.58
Fixed leg length	(in)	42
Adjustable legs	(in)	38.06-51.81
Turning radius	(in)	69.09
Overall length	(in)	81.69
Max width	(in)	46.93-60.71
Extended mast height	(in)	253.15
Lowered mast height	(in)	98.03
Battery voltage	(V/Ah)	24/210Ah
Charger	(V/A)	24V/30A
Lifting Motor	(W)	3000-Watt, Lift speed, laden/unladen:95/160m/s Lowering speed, laden/unladen:130/110mm/s
AC Driving Motor	(W)	3000 Watt, Driving speed: laden/unladen: 5.2/5.5km/h
Service Weight	(lb.)	3542

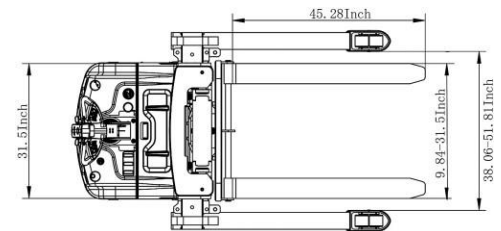
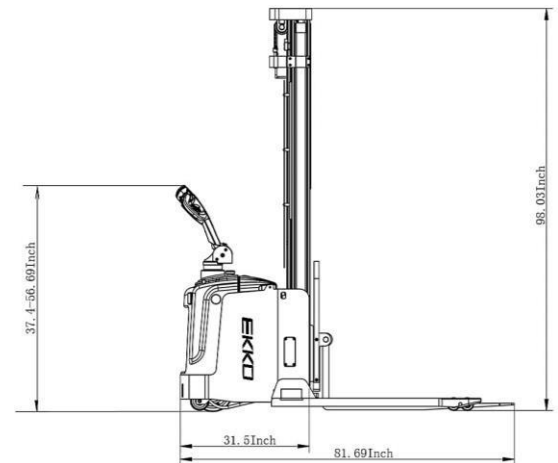

# EB12E-98LI Full Powered Lithium Walkie Stacker

The EKKO EB12E-98Li LITHIUM IRON PHOSPHATE Electric Straddle Stacker with a 72" lowered mast can get underneath any doorway and is designed with the combination of the versatility of a forklift, reach truck and a walkie stacker. It is ideal for loading and unloading trucks, loading docks, stock rooms, manufacturing floors and warehousing.

Made from high quality steel and components with durable quality drives to withstand any terrain, usage, impact and directional changes for the use of any application with confidence and assurance.

- Load Capacity 2640 lb.
- Lowered Mast 72"
- Raised Height 98"
- Adjustable Forks 8.3-33.5"
- Adjustable Legs 45.7-59.1"
- Fork Length 45.3"
- Curtis Instrument Controller
- 24V Drive Motor
- 24V Lift Motor
- Battery 24V/50Ah Lithium
- Polyurethane Wheels
- Ergonomic Handle and Controls
- Steel Construction
- Robotic Welding
- 3 Year Limited Warranty

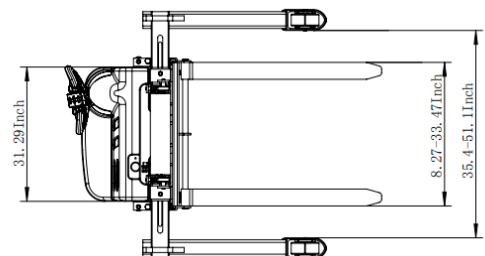
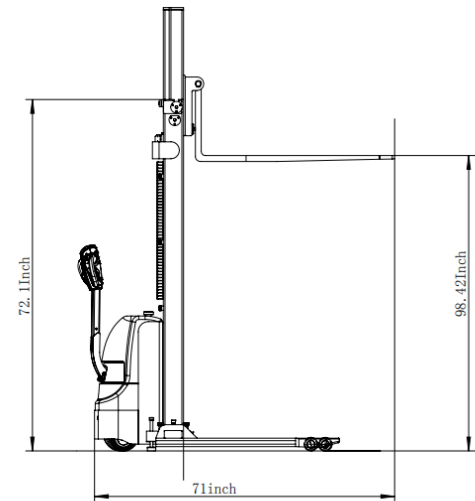

Model		EB12E-98Li
Load capacity	(lbs.)	2640
The max. lifting height	(in)	98"
Load center distance	(in)	24
Fork length	(in)	45.3
Single fork width	(in)	4
Overall fork width	(in)	8.3-33.5
Lowered fork height	(in)	2.35
Fixed leg length	(in)	36.5
Adjustable legs	(in)	45.5-59.1
Turning radius	(in)	52.6
Overall length	(in)	70
Max Overall width	(in)	61
Extended mast height	(in)	114
Lowered mast height	(in)	72
Battery voltage (dimensions)	(in)	Li-Iron 24V/50Ah (10/6.6/8.5)
Internal Charger	V/A	24V/15A
Lifting Motor	V/Kw	2.2kw. Lift speed, laden/unladen:92/136mm/s Lowering speed, laden/unladen:112/98mm/s
Driving Motor		0.75kw. Driving speed: laden/unladen:4.0/4.2km/h
Service Weight	(lbs.)	1300

## EB13E-Li Lithium-Iron Walkie Stacker



The EKKO EB13E-Li Lithium Electric Straddle Stacker is designed with the combination of the versatility of a forklift, reach truck and a walkie stacker. It is ideal for loading and unloading trucks, loading docks, stock rooms, manufacturing floors and warehousing.

Made from high quality steel and components with durable quality drives to withstand any terrain, usage, impact and directional changes for the use of any application with confidence and assurance.

- Load Capacity 2800 lb.
- Raised Height 119"
- Adjustable Forks 8.3-33.5"
- Adjustable Legs 45.7-59.1"
- Fork Length 45.3"
- Curtis Instrument Controller
- **24V Center Drive Motor**
- 24V Lift Motor
- Battery 24V/50Ah Lithium
- Polyurethane Wheels
- Ergonomic Handle and Controls
- Steel Construction
- Robotic Welding
- 3 Year Limited Warranty

Model		EB13E-Li
Load capacity	(lb.)	2800
The max. lifting height	(in)	119"
Load center distance	(in)	24
Fork length	(in)	45.3
Single fork width	(in)	4
Overall fork width	(in)	8.3-33.5
Lowered fork height	(in)	2.35
Fixed leg length	(in)	36.5
Adjustable legs	(in)	45.5-59.1
Turning radius	(in)	52.6
Overall length	(in)	70
Max Overall width	(in)	61
Extended mast height	(in)	135
Lowered mast height	(in)	82
Battery voltage	(V/A)	24V-50AH Lithium
Internal Charger	(V/A)	24V/15A
Lifting Motor	(V/W)	2000-Watt, Lift speed, laden/unladen:92/136mm/s Lowering speed, laden/unladen:112/98mm/s
Driving Motor	(W)	750 Watt, Driving speed: laden/unladen:4.0/4.2km/h
Service Weight	(lb.)	1325



## EB13ES-119Li Lithium-Iron Walkie Stacker



The EKKO EB13ES-119Li Lithium Straddle Stacker with side-shift is designed with the combination of the versatility of a forklift, reach truck and a walkie stacker. It is ideal for loading and unloading trucks, loading docks, stock rooms, manufacturing floors and warehousing.

Made from high quality steel and components with durable quality drives to withstand any terrain, usage, impact and directional changes for the use of any application with confidence and assurance.

- LITHIUM LiFePO4
- 2800 lbs. Capacity
- 145 in. Lift Height
- **Side-Shift**
- Narrow Aisles 7 ft.
- Adjustable Legs 45.5-59.1 in.
- Adjustable Forks 8.3-33.5 in.
- 24V Center Drive Motor
- Curtis Instrument Controller
- Lithium Iron Phosphate Battery & Charger Included
- 3 Year Limited Warranty

Model		EB13E-119Li
Load capacity	(lb.)	2800
The max. lifting height	(in)	119"
Load center distance	(in)	24
Fork length	(in)	45.3
Side-Shift		3-WAY VALVE
Single fork width	(in)	4
Overall fork width	(in)	8.3-33.5
Lowered fork height	(in)	2.35
Fixed leg length	(in)	36.5
Adjustable legs	(in)	45.5-59.1
Turning radius	(in)	52.6
Overall length	(in)	70
Max Overall width	(in)	61
Extended mast height	(in)	135
Lowered mast height	(in)	82
Battery voltage	(V/A)	24V/50AH Lithium
Internal Charger	(V/A)	24V/15A
Lifting Motor	(V/W)	2000-Watt, Lift speed, laden/unladen:92/136mm/s Lowering speed, laden/unladen:112/98mm/s
Driving Motor	(W)	750 Watt, Driving speed: laden/unladen:4.0/4.2km/h
Service Weight	(lb.)	1495



## EB13E-138Li Lithium-Iron Walkie Stacker

The EKKO EB13-138LI Lithium Electric Straddle Stacker is designed with the combination of the versatility of a forklift, reach truck and a walkie stacker. It is ideal for loading and unloading trucks, loading docks, stock rooms, manufacturing floors and warehousing.

Made from high quality steel and components with durable quality drives to withstand any terrain, usage, impact and directional changes for the use of any application with confidence and assurance.

- Load Capacity 2800 lb.
- Raised Height 138"
- Adjustable Forks 8.3-33.5"
- Adjustable Legs 45.7-59.1"
- Fork Length 45.3"
- Curtis Instrument Controller
- **24V Center Drive Motor**
- 24V Lift Motor
- Battery 24V/50Ah Lithium
- Polyurethane Wheels
- Ergonomic Handle and Controls
- 3 Year Limited Warranty



Model		EB13E-138Li
Load capacity	(lb.)	2800
The max. lifting height	(in)	138"
Load center distance	(in)	24
Fork length	(in)	45.3
Single fork width	(in)	4
Overall fork width	(in)	8.3-33.5
Lowered fork height	(in)	2.35
Fixed leg length	(in)	36.5
Adjustable legs	(in)	45.5-59.1
Turning radius	(in)	52.6
Overall length	(in)	70
Max Overall width	(in)	61
Extended mast height	(in)	154
Lowered mast height	(in)	92
Battery voltage	(V/A)	24V/50AH Lithium
Internal Charger	(V/A)	24V/15A
Lifting Motor	(V/W)	2000-Watt, Lift speed, laden/unladen:92/136mm/s Lowering speed, laden/unladen:112/98mm/s
Driving Motor	(W)	750 Watt, Driving speed: laden/unladen:4.0/4.2km/h
Service Weight	(lb.)	1365

## EB13E-145Li Lithium-Iron Walkie Stacker



Model		EB13E-145Li
Load capacity	(lb.)	2800
The max. lifting height	(in)	145"
Load center distance	(in)	24
Fork length	(in)	45.3
Single fork width	(in)	4
Overall fork width	(in)	8.3-33.5
Lowered fork height	(in)	2.35
Fixed leg length	(in)	36.5
Adjustable legs	(in)	45.5-59.1
Turning radius	(in)	52.6
Overall length	(in)	70
Max Overall width	(in)	61
Extended mast height	(in)	167
Lowered mast height	(in)	95.66
Battery voltage	(V/A)	24V/50AH Lithium
Internal Charger	(V/A)	24V/15A
Lifting Motor	(V/W)	2000-Watt, Lift speed, laden/unladen:92/136mm/s Lowering speed, laden/unladen:112/98mm/s
Driving Motor	(W)	750 Watt, Driving speed: laden/unladen:4.0/4.2km/h
Service Weight	(lb.)	1390

The EKKO EB13E-145Li Lithium Straddle Stacker is designed with the combination of the versatility of a forklift, reach truck and a walkie stacker. It is ideal for loading and unloading trucks, loading docks, stock rooms, manufacturing floors and warehousing.

Made from high quality steel and components with durable quality drives to withstand any terrain, usage, impact and directional changes for the use of any application with confidence and assurance.

- Load Capacity 2800 lb.
- Raised Height 145"
- Adjustable Forks 8.3-33.5"
- Adjustable Legs 45.7-59.1"
- Fork Length 45.3"
- Curtis Instrument Controller
- **24V Center Drive Motor**
- 24V Lift Motor
- Battery 24V/50Ah Lithium
- Polyurethane Wheels
- Ergonomic Handle and Controls
- Steel Construction
- Robotic Welding
- 3 Year Limited Warranty

# EB13ES-145Li Lithium-Iron Walkie Stacker



The EKKO EB13ES-145Li Lithium Straddle Stacker with side-shift is designed with the combination of the versatility of a forklift, reach truck and a walkie stacker. It is ideal for loading and unloading trucks, loading docks, stock rooms, manufacturing floors and warehousing.

Made from high quality steel and components with durable quality drives to withstand any terrain, usage, impact and directional changes for the use of any application with confidence and assurance.

- LITHIUM LiFePO4
- 2640 lbs. Capacity
- 145 in. Lift Height
- **Side-Shift**
- Narrow Aisles 7 ft.
- Adjustable Legs 45.5-59.1 in.
- Adjustable Forks 8.3-33.5 in.
- 24V Center Drive Motor
- Curtis Instrument Controller
- Lithium Iron Phosphate Battery & Charger Included
- 3 Year Limited Warranty

Model		EB13E-145Li
Load capacity	(lb.)	2640
The max. lifting height	(in)	145"
Load center distance	(in)	24
Fork length	(in)	45.3
Side-Shift		
Single fork width	(in)	4
Overall fork width	(in)	8.3-33.5
Lowered fork height	(in)	2.35
Fixed leg length	(in)	36.5
Adjustable legs	(in)	45.5-59.1
Turning radius	(in)	52.6
Overall length	(in)	70
Max Overall width	(in)	61
Extended mast height	(in)	167
Lowered mast height	(in)	95.66
Battery voltage	(V/A)	24V/50AH Lithium
Internal Charger	(V/A)	24V/15A
Lifting Motor	(V/W)	2000 Watt, Lift speed, laden/unladen:92/136mm/s Lowering speed, laden/unladen:112/98mm/s
Driving Motor	(W)	750 Watt, Driving speed: laden/unladen:4.0/4.2km/h
Service Weight	(lb.)	1665



## EB16EAS-189LI Lithium-Iron Walkie Stacker

The EKKO EB16EAS-189LI Electric Straddle Stacker is designed with the combination of the versatility of a forklift, reach truck and a walkie stacker with SIDE-SHIFTING capabilities. It is ideal for loading and unloading trucks, loading docks, stock rooms, manufacturing floors and warehousing.

Made from high quality steel and components with durable quality drives to withstand any terrain, usage, impact and directional changes for the use of any application with confidence and assurance.

- Load Capacity 4400 lb.
- Raised Height 189"
- Side-Shift
- Adjustable Forks 8.27-31.5"
- Adjustable Legs 38.06-51.8"
- Fork Length 45.3"
- Free Lift 51.85"
- EPS (Electric Power Steering)
- Curtis Instrument Controller
- 24V Center AC Drive Motor
- 24V Lift Motor
- Triple Mast
- Battery 24V/210Ah
- Ergonomic Handle and Controls
- 3 Year Limited Warranty



Model		EB16EAS-189LI
Load capacity	(lb.)	4400
The max. lifting height	(in)	189
Load center distance	(in)	23.62
Free Lift	(in)	51.85
EPS (Elec. Power Steer)		Yes
Fork length	(in)	45.28
Single fork width	(in)	4.7
Overall fork width	(in)	8.27-31.5
Lowered fork height	(in)	1.57
Fixed leg length	(in)	42
Adjustable legs	(in)	38.06-51.81
Turning radius	(in)	68.5
Overall length	(in)	83.26
Max width	(in)	46.93-60.71
Extended mast height	(in)	227
Lowered mast height	(in)	88.86
Battery voltage	(V/Ah)	24/150Ah Li
Charger	(V/A)	24V/30A
Lifting Motor	(W)	3000 Watt, Lift speed, laden/unladen:95/160m/s Lowering speed, laden/unladen:130/110mm/s
AC Driving Motor	(W)	3000 Watt, Driving speed: laden/unladen: 5.2/5.5km/h
Service Weight	(lb.)	3520

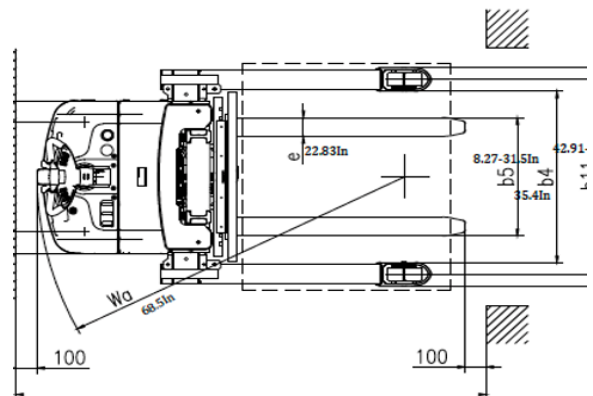
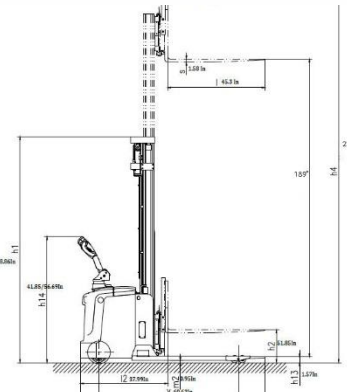



# EPC30A Center-Controlled Rider Pallet Jack

The EKKO EPC30A Center-Controlled Rider Pallet Jack is designed with the versatility of a pallet jack with full power lifting and driving capabilities. It is ideal for long hauls, loading and unloading trucks, loading docks, stock rooms, manufacturing floors and warehousing.

Made from high quality steel and components with durable quality drives to withstand any terrain, usage, impact and directional changes for the use of any application with confidence and assurance.

- Load Capacity 5000 lb.
- Fork Size 27x45"
- Curtis Instrument Controller
- German AC Drive
- Raised Height 7.88"
- Lowered Height 3.35"
- Polyurethane Wheels
- Ergonomic Handle and Controls



Model		EPC30A
Lift		Electric
Drive		Electric
Load capacity	(lb.)	5000
Load center	(in)	23.6
Wheelbase	(in)	81.89
Lowered fork height	(in)	3.35
Lifting height	(in)	7.88
Overall length	(in)	99.09
Overall width	(in)	31.81
Fork size	s/e/l (in)	1.97x7.69x45.3
Outside distance of fork	(in)	26.97
Turning radius	(in)	89.68
Lifting speed, laden/unladen	(in/s)	.90/.94
Lowering speed, laden/unladen	(in/s)	1.18/.78
Max gradient performance laden/unladen	(%)	3/6
Brake type		electromagnetic
Drive motor	(W)	1500
Lift motor	(W)	800
Charger	(V/A)	N/A
Battery voltage/rated capacity	(V/Ah)	24V/360Ah
AC Drive Motor		AC Motor
Noise level at operator seat	(dB(A))	70
Service weight (with battery)	(lb.)	2400

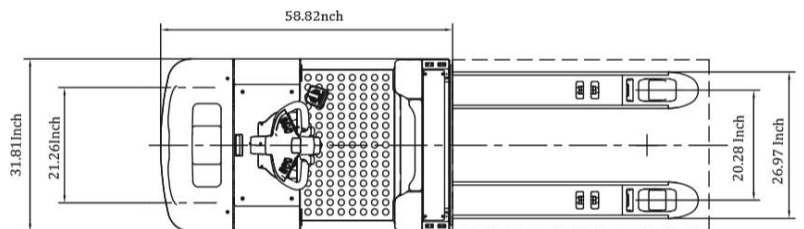
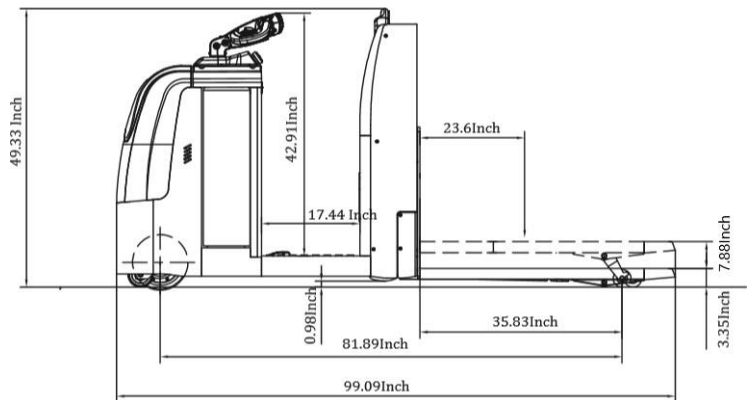

## EP30A Rider Pallet Jack

The EKKO EP30A Rider Pallet Jack is designed with the versatility of a pallet jack with full power lifting and driving capabilities. It is ideal for loading and unloading trucks, loading docks, stock rooms, manufacturing floors and warehousing.

Made from high quality steel and components with durable quality drives to withstand any terrain, usage, impact and directional changes for the use of any application with confidence and assurance.

- Load Capacity 6600 lb.
- Fork Size 27x48
- Curtis Instrument Controller
- Raised Height 9.17"
- Lowered Height 3.26"
- Polyurethane Wheels
- Ergonomic Handle and Controls
- Steel Construction
- Robotic Welding
- 3 Year Limited Warranty



Model		EP30A
Lift		Electric
Drive		Electric
Load capacity	(lb.)	6600
Load center	(in)	24
Wheelbase	(in)	67.72
Lowered fork height	(in)	3.26
Lifting height	(in)	9.17
Overall length	(in)	88.58
Overall width	(in)	35.83
Fork size	s/e/l (in)	2/9/48
Outside distance of fork	in	27
Turning radius	(in)	81.34
Lifting speed, laden/unladen	(in/s)	7.5/8
Lowering speed, laden/unladen	(in/s)	36/30
Max gradient performance laden/unladen	(%)	5/15
Brake type		electromagnetic
Drive motor	(W)	3000
Lift motor	(W)	2200
Charger	(V/A)	N/A
Battery voltage/rated capacity	(V/Ah)	24V/280Ah
AC Drive Motor		AC Motor
Noise level at operator seat	(dB(A))	70
Service weight (with battery)	(lb.)	1720

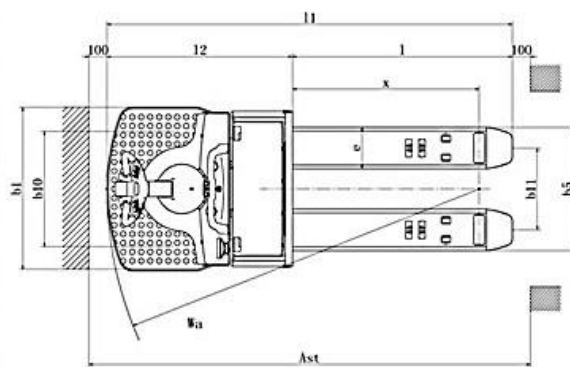
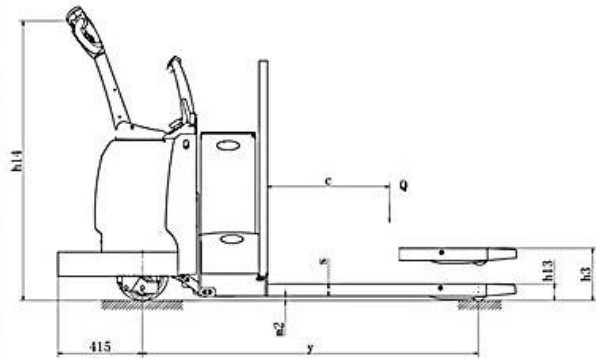

## EP30A-LI Lithium Rider Pallet Jack

The EKKO EP30A-LI Rider Pallet Jack is designed with the versatility of a palletjack with full power lifting and driving capabilities. It is ideal for loading and unloading trucks, loading docks, stock rooms, manufacturing floors and warehousing.

Made from high quality steel and components with durable quality drives to withstand any terrain, usage, impact and directional changes for the use of any application with confidence and assurance.

- Load Capacity 6600 lb.
- Fork Size 27x48
- Curtis Instrument Controller
- Raised Height 9.17"
- Lowered Height 3.26"
- Polyurethane Wheels
- Ergonomic Handle and Controls
- Steel Construction
- Robotic Welding
- 3 Year Limited Warranty



Model		EP30A
Lift		Electric
Drive		Electric
Load capacity	(lb.)	6600
Load center	(in)	24
Wheelbase	(in)	67.72
Lowered fork height	(in)	3.26
Lifting height	(in)	9.17
Overall length	(in)	88.58
Overall width	(in)	35.83
Fork size	s/e/l (in)	2/9/48
Outside distance of fork	(in)	27
Turning radius	(in)	81.34
Lifting speed, laden/unladen	(in/s)	7.5/8
Lowering speed, laden/unladen	(in/s)	36/30
Max gradient performance laden/unladen	(%)	5/15
Brake type		electromagnet
Drive motor	(W)	3000
Lift motor	(W)	2200
Charger	(V/A)	N/A
Battery voltage/rated capacity	(V/Ah)	24V/150AH Lithium
AC Drive Motor		AC Motor
Noise level at operator sear	(dB(A))	70

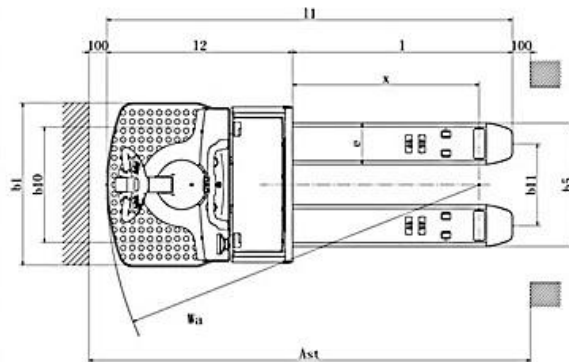
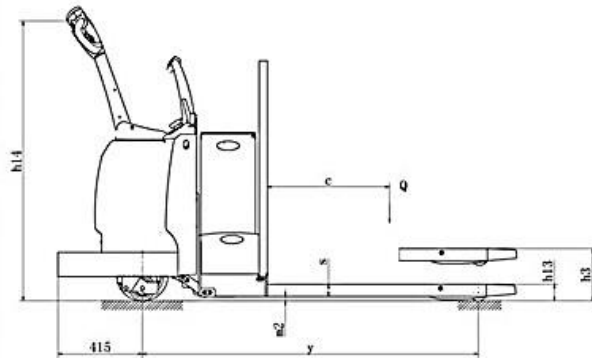

## EKKO EP20E Walkie Pallet Jack

The EKKO EP20E Electric Walkie Pallet Jack is designed with the versatility of a pallet jack with full power lifting and driving capabilities. It is ideal for loading and unloading trucks, loading docks, stock rooms, manufacturing floors and warehousing.

Made from high quality steel and components with durable quality drives to withstand any terrain, usage, impact and directional changes for the use of any application with confidence and assurance.

- Load Capacity 4400 lb.
- Fork Size 27x48
- Curtis Instrument Controller
- Raised Height 7.9"
- Lowered Height 3.3"
- Polyurethane Wheels
- Ergonomic Handle and Controls
- Steel Construction
- Robotic Welding
- 3 Year Limited Warranty



Model		EP20E
Lift		Electric
Drive		Electric
Load capacity	(lb.)	4400
Load center	(in)	24
Wheelbase	(in)	53
Lowered fork height	(in)	3.3
Lifting height	(in)	7.9
Overall length	(in)	71.2
Overall width	(in)	28
Fork size	s/e/l (in)	2/6/48
Outside distance of fork	(in)	27
Turning radius	(in)	60
Lifting speed, laden/unladen	(in/s)	0.8/1.1
Lowering speed, laden/unladen	(in/s)	1.5/1.5
Max gradient performance laden/unladen	(%)	8/15
Brake type		electromagnetic
Drive motor	(W)	1300W
Lift motor	(W)	
Charger	(V/A)	24V/15A
Battery voltage/rated capacity	(V/Ah)	24V/160Ah
AC Drive Motor		AC Motor speed control
Noise level at operator seat	(dB(A))	68
Service weight with battery	(lb.)	860

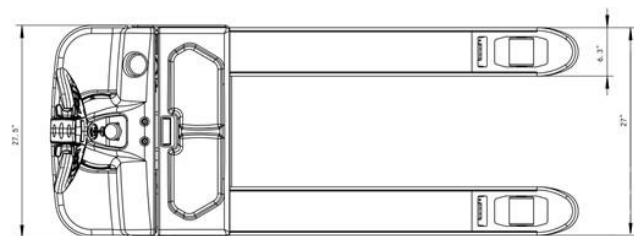
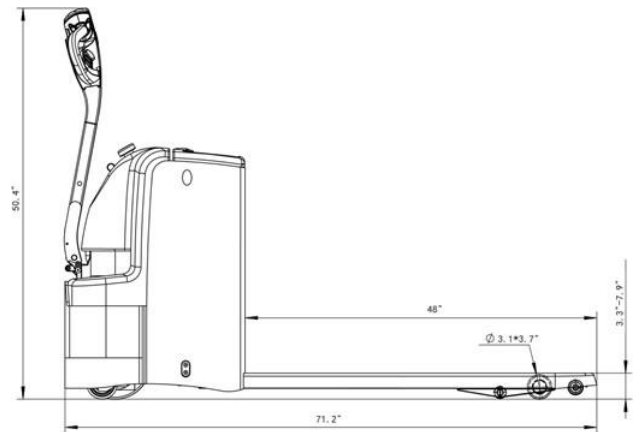

# EKKO EP25E Walkie Pallet Jack

The EKKO EP25E Electric Walkie Pallet Jack is designed with the versatility of a pallet jack with full power lifting and driving capabilities. It is ideal for loading and unloading trucks, loading docks, stock rooms, manufacturing floors and warehousing.

Made from high quality steel and components with durable quality drives to withstand any terrain, usage, impact and directional changes for the use of any application with confidence and assurance.

- Load Capacity 5500 lb.
- Fork Size 27x48
- Curtis Instrument Controller
- Raised Height 7.9"
- Lowered Height 3.3"
- Polyurethane Wheels
- Ergonomic Handle and Controls
- Steel Construction
- Robotic Welding
- 3 Year Limited Warranty



Model		EP25E
Lift		Electric
Drive		Electric
Load capacity	(lb.)	5500
Load center	(in)	24
Wheelbase	(in)	53
Lowered fork height	(in)	3.33
Lifting height	(in)	7.9
Overall length	(in)	71.2
Overall width	(in)	27.5
Fork size	s/e/l (in)	2/6/48
Outside distance of fork	in	27
Turning radius	(in)	60
Lifting speed, laden/unladen	(in/s)	0.8/1.1
Lowering speed, laden/unladen	(in/s)	1.5/1.5
Max gradient performance laden/unladen	(%)	8/15
Brake type		electromagnetic
Drive motor	(W)	1300W
Lift motor	(W)	800W
Charger	(V/A)	24V/30A
Battery voltage/rated capacity	(V/Ah)	24V/240Ah
AC Drive Motor		AC Motor speed control
Noise level at operator seat	(dB(A))	68
Service weight (with battery)	(lb.)	1100

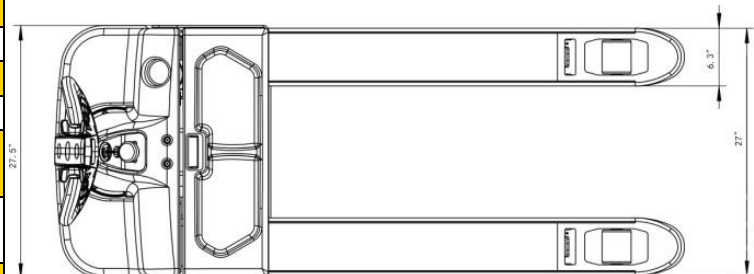
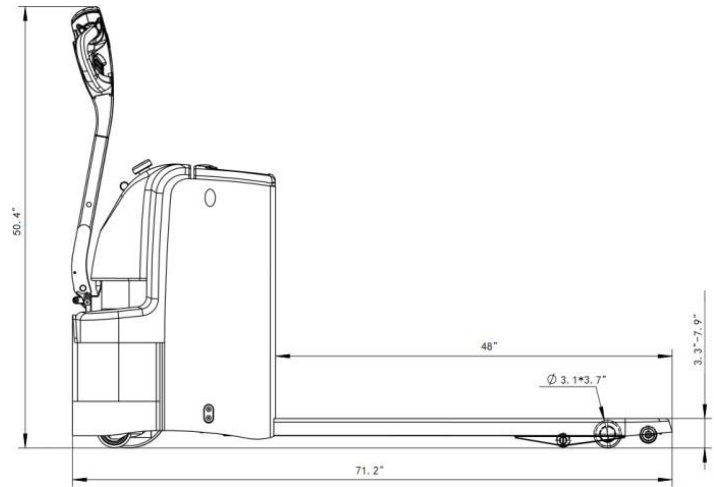

# EKKO EP18LI LITHIUM-IRON Walkie Pallet Jack

The EKKO EP18LI Lithium Iron Phosphate Electric Walkie Pallet Jack is designed with the versatility of a pallet jack with full power lifting and driving capabilities. It is ideal for loading and unloading trucks, loading docks, stock rooms, manufacturing floors and warehousing.

Made from high quality steel and components with durable quality drives to withstand any terrain, usage, impact and directional changes for the use of any application with confidence and assurance.

- Load Capacity 4000 lb.
- Fork Size 27x48
- Raised Height 7.7"
- Lowered Height 3.3"
- Polyurethane Wheels
- Ergonomic Handle and Controls
- Steel Construction
- Robotic Welding
- Built-in Charger
- 3 Year Limited Warranty

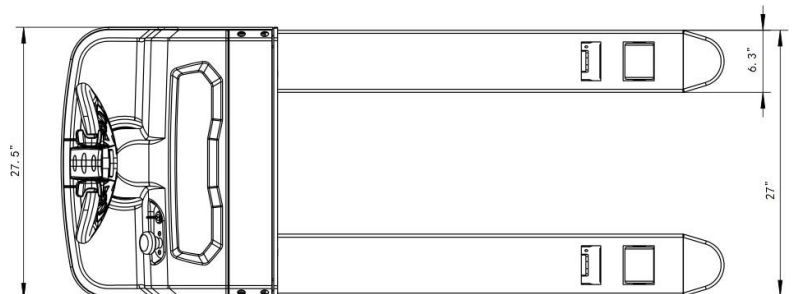
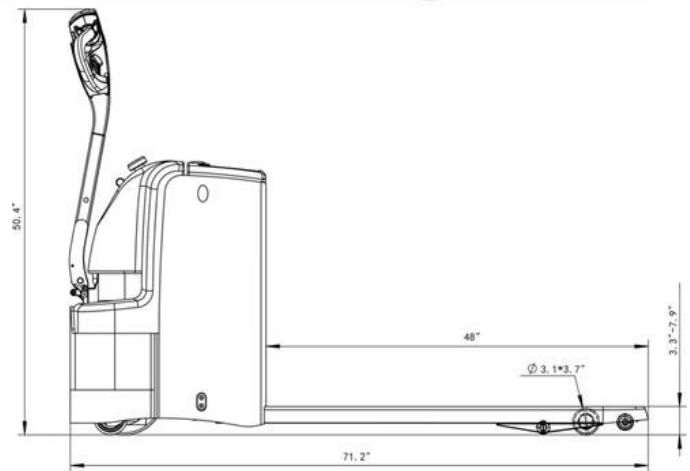

Model		EP18LI
Lift		Electric
Drive		Electric
Load capacity	(lb.)	4000
Load center	(in)	24
Wheelbase	(in)	53
Lowered fork height	(in)	3.3
Lifting height	(in)	7.7
Overall length	(in)	67.2
Overall width	(in)	27.5
Fork size	s/e/l (in)	2/6/48
Outside distance of fork	(in)	27
Turning radius	(in)	55
Lifting speed, laden/unladen	(in/s)	0.8/1.1
Lowering speed, laden/unladen	(in/s)	1.5/1.5
Max gradient performance laden/unladen	(%)	8/15
Brake type		electromagnetic
Drive motor	(W)	750W
Lift motor	(W)	80WLITHIUM
Lithium-Iron Battery voltage/rated capacity	(V/Ah)	24V/40Ah Li
DC Drive Motor		DC Motor speed control
Noise level at operator seat	(dB(A))	68
Service weight (with battery)	(lb.)	650

# EKKO EP20LI LITHIUM-IRON Walkie Pallet Jack

The EKKO EP20LI LITHIUM-IRON Phosphate Electric Walkie Pallet Jack is designed with the versatility of a pallet jack with full power lifting and driving capabilities. It is ideal for loading and unloading trucks, loading docks, stock rooms, manufacturing floors and warehousing.

Made from high quality steel and components with durable quality drives to withstand any terrain, usage, impact and directional changes for the use of any application with confidence and assurance.

- Load Capacity 4400 lb.
- Fork Size 27x48
- Raised Height 7.7"
- Lowered Height 3.3"
- Polyurethane Wheels
- Ergonomic Handle and Controls
- Steel Construction
- Robotic Welding
- Built-in Charger
- 3 Year Limited Warranty

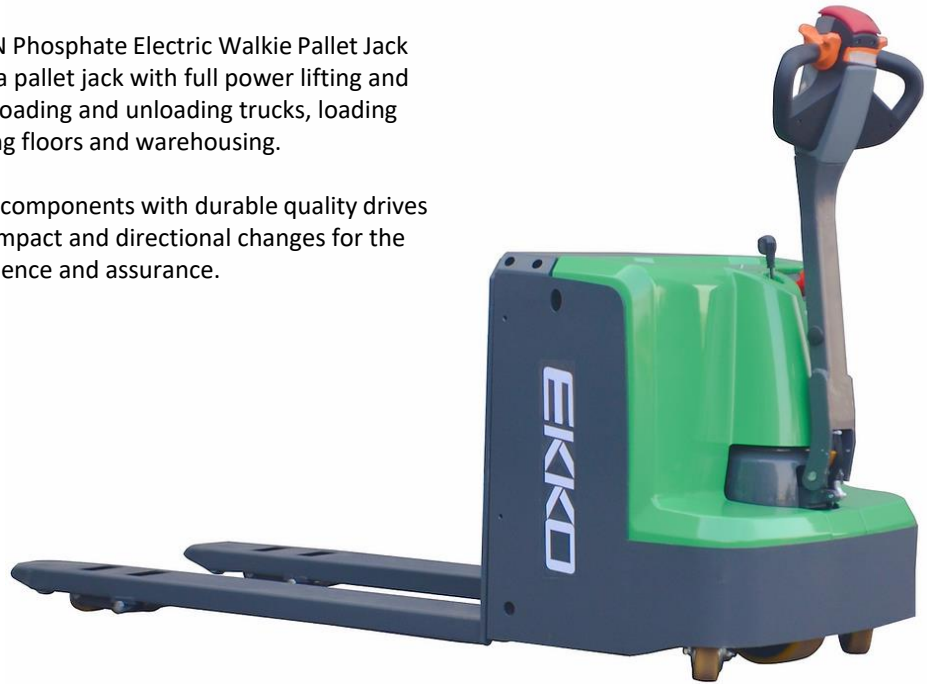

Model		EP20LI
Lift		Electric
Drive		Electric
Load capacity	(lb.)	4400
Load center	(in)	24
Wheelbase	(in)	53
Lowered fork height	(in)	3.3
Lifting height	(in)	7.7
Overall length	(in)	67.2
Overall width	(in)	27.5
Fork size	s/e/l (in)	2/6/48
Outside distance of fork	(in)	27
Turning radius	(in)	55
Lifting speed, laden/unladen	(in/s)	0.8/1.1
Lowering speed, laden/unladen	(in/s)	1.5/1.5
Max gradient performance laden/unladen	(%)	8/15
Brake type		electromagnetic
Drive motor	(W)	750W
Lift motor	(W)	80WLITHIUM
Lithium-iron Battery voltage/rated capacity	(V/Ah)	24V/60Ah Li
DC Drive Motor		DC Motor speed control
Noise level at operator seat	(dB(A))	68
Service weigh (with battery)	(lb.)	680

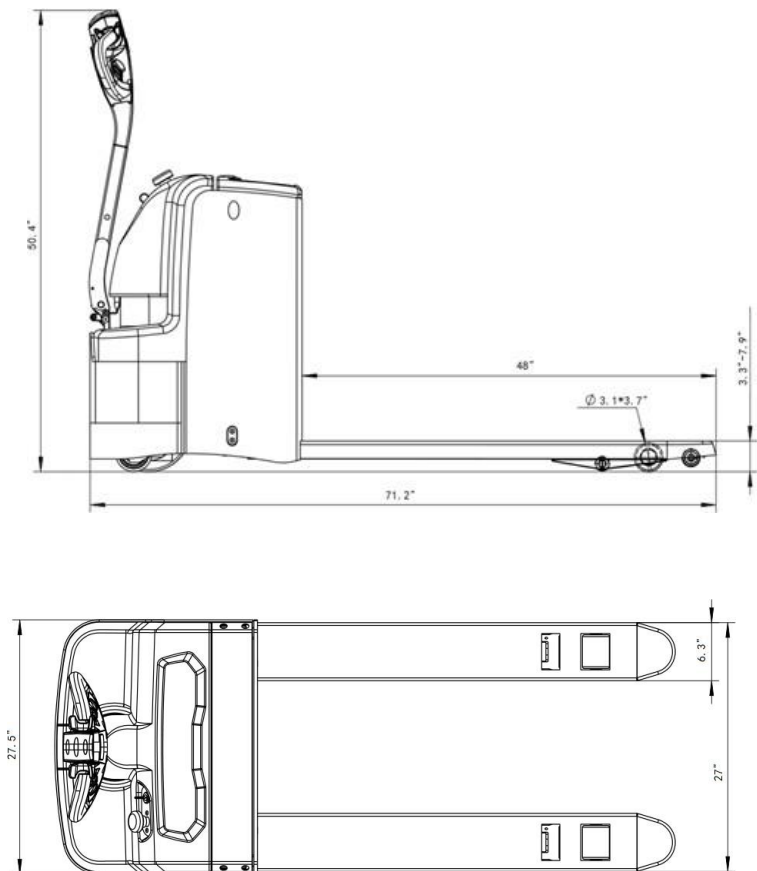

# EKKO EP15JLI LITHIUM-IRON Walkie Pallet Jack

The EKKO EP-JLI series Lithium Iron Phosphate Electric Walkie Pallet Jacks are designed with the versatility of a pallet jack with full power lifting and driving capabilities. It is ideal for loading and unloading trucks, loading docks, stock rooms, manufacturing floors and warehousing.

Made from high quality steel and components with durable quality drives to withstand any terrain, usage, impact and directional changes for the use of any application with confidence and assurance.

- Lithium 24V Powered.
- Load Capacity 3300 lb.
- Fork Size 27x48
- Raised Height 7.87"
- Lowered Height 3.35"
- Pinwheel Capability
- Polyurethane Wheels
- Ergonomic Handle and Controls
- Steel Construction
- Robotic Welding
- Charger Included
- (1) Lithium Ion LiFePO4 Battery
- 3 Years Limited Warranty

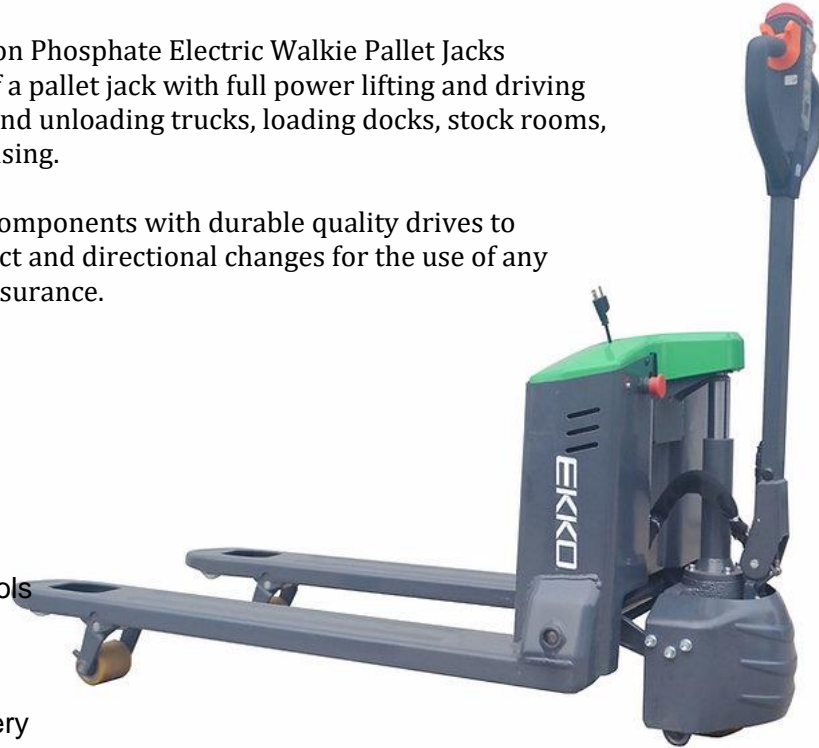

Model		EP15JLI
Lift		Electric
Drive		Electric
Load capacity	(lb.)	3300
Load center	(in)	23.6
Wheelbase	(in)	47.6
Lowered fork height	(in)	3.35
Lifting height	(in)	7.8
Overall length	(in)	61.81
Overall width	(in)	27
Fork size	s/e/l (in)	1.97/5.9/48
Fork Width	(in)	61.81
Turning radius	(in)	53.7
Lifting speed, laden/unladen	(in/s)	N/A
Lowering speed, laden/unladen	(in/s)	N/A
Max gradient performance laden/unladen	(%)	5/10
Brake type		electromagnetic
Drive motor	(KW)	0.75
Lift motor	(KW)	0.8
Battery voltage/rated capacity	(V/Ah)	24V/30Ah Li
DC Drive Motor		DC Motor speed control
Noise level at operator seat	(dB(A))	70
Service weight with battery	(lb.)	308

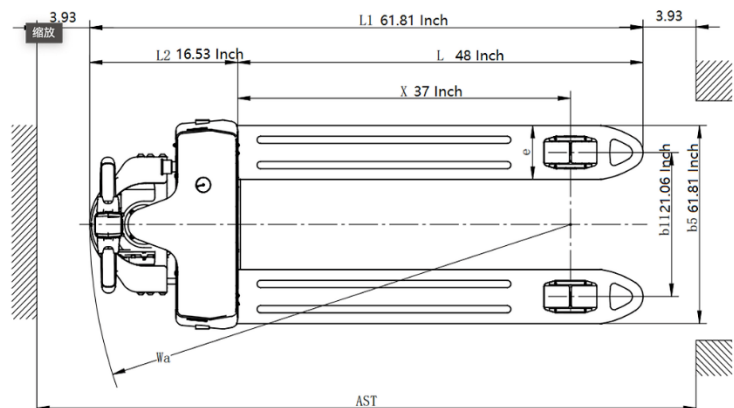
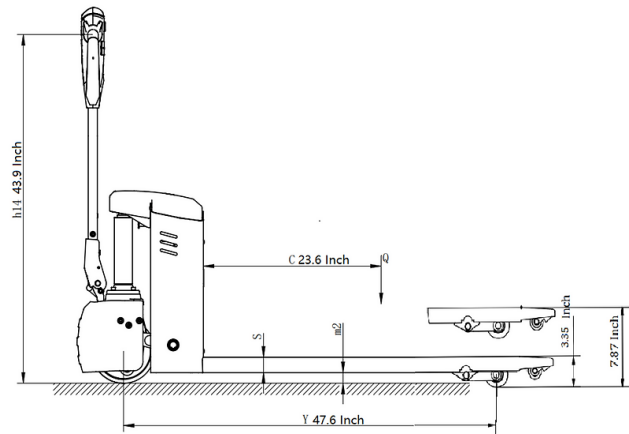



# EKKO EP18JLI LITHIUM-IRON Walkie Pallet Jack

The EKKO EP18JLI Lithium Iron Phosphate Electric Walkie Pallet Jack is designed with the versatility of a pallet jack with full power lifting and driving capabilities. It is ideal for loading and unloading trucks, loading docks, stock rooms, manufacturing floors and warehousing.

Made from high quality steel and components with durable quality drives to withstand any terrain, usage, impact and directional changes for the use of any application with confidence and assurance.

- Lithium 24V Powered.
- Load Capacity 4000 lb.
- Fork Size 27x48
- Raised Height 7.8"
- Lowered Height 3.35"
- Pinwheel Capability
- Polyurethane Wheels
- Ergonomic Handle and Controls
- Steel Construction
- Robotic Welding
- Charger Included
- (1) Lithium Ion Battery LiFePO4 Included 24V/40Ah
- 3 Years Limited Warranty



Model		EP18JLI
Lift		Electric
Drive		Electric
Load capacity	(lb.)	4000
Load center	(in)	23.6
Wheelbase	(in)	47.6
Lowered fork height	(in)	3.35
Lifting height	(in)	7.8
Overall length	(in)	61.81
Overall width	(in)	27
Fork size	s/e/l (in)	1.97/5.9/48
Fork Width	(in)	61.81
Turning radius	(in)	53.7
Lifting speed, laden/unladen	(in/s)	N/A
Lowering speed, laden/unladen	(in/s)	N/A
Max gradient performance laden/unladen	(%)	5/10
Brake type		electromagnetic
Drive motor	(KW)	0.75
Lift motor	(KW)	0.8
Battery voltage/rated capacity	(V/Ah)	24V/40Ah Li
DC Drive Motor		DC Motor speed control
Noise level at operator seat	(dB(A))	70
Service weight with battery	(lb.)	319

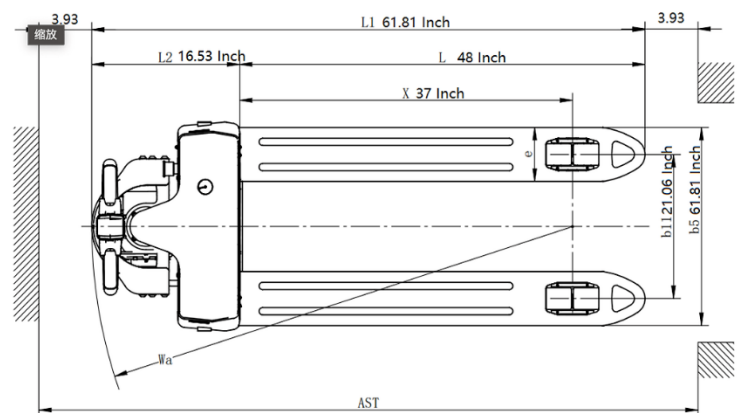
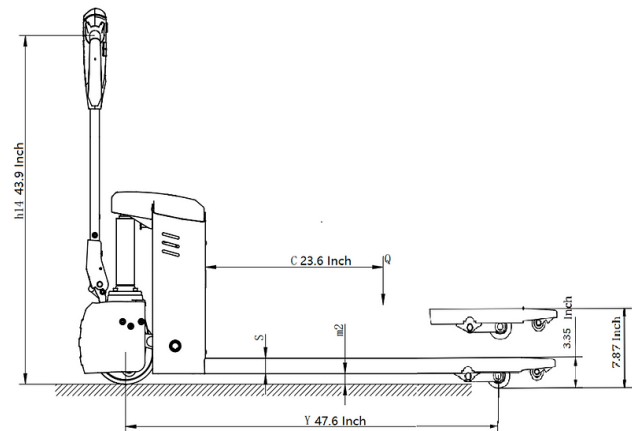

# EKKO EP20JLI LITHIUM-IRON Walkie Pallet Jack

The EKKO EP20JLI Lithium Iron Phosphate Electric Walkie Pallet Jack is designed with the versatility of a pallet jack with full power lifting and driving capabilities. It is ideal for loading and unloading trucks, loading docks, stock rooms, manufacturing floors and warehousing.

Made from high quality steel and components with durable quality drives to withstand any terrain, usage, impact and directional changes for the use of any application with confidence and assurance.

- Lithium 48V Powered.
- Load Capacity 4400 lb.
- Fork Size 27x48
- Raised Height 7.8"
- Lowered Height 3.35"
- Pinwheel Capability
- Polyurethane Wheels
- Ergonomic Handle and Controls
- Steel Construction
- Robotic Welding
- Charger Included
- (1) Lithium Ion Battery LiFePO4 Included 48V/20Ah
- 3 Years Limited Warranty



Model		EP20JLI
Lift		Electric
Drive		Electric
Load capacity	(lb.)	4400
Load center	(in)	23.6
Wheelbase	(in)	47.6
Lowered fork height	(in)	3.35
Lifting height	(in)	7.8
Overall length	(in)	61.81
Overall width	(in)	27
Fork size	s/e/l (in)	1.97/5.9/48
Fork Width	(in)	61.81
Turning radius	(in)	53.7
Lifting speed, laden/unladen	(in/s)	N/A
Lowering speed, laden/unladen	(in/s)	N/A
Max gradient performance laden/unladen	(%)	5/10
Brake type		electromagnetic
Drive motor	(KW)	1
Lift motor	(KW)	0.8
Battery voltage/rated capacity	(V/Ah)	48V/20Ah Li
DC Drive Motor		DC Motor speed control
Noise level at operator seat	(dB(A))	70
Service weight with battery	(lb.)	326

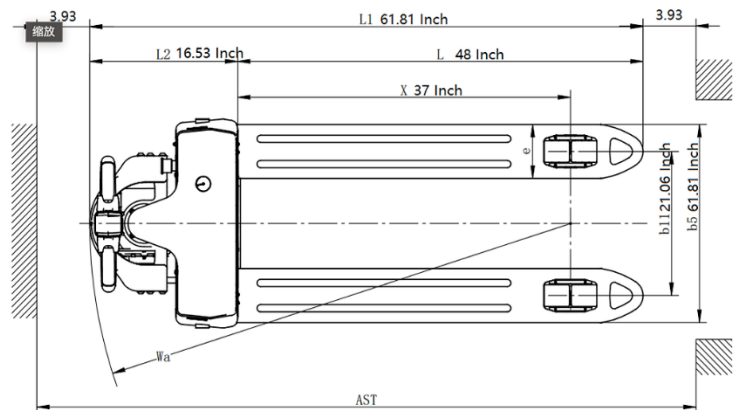
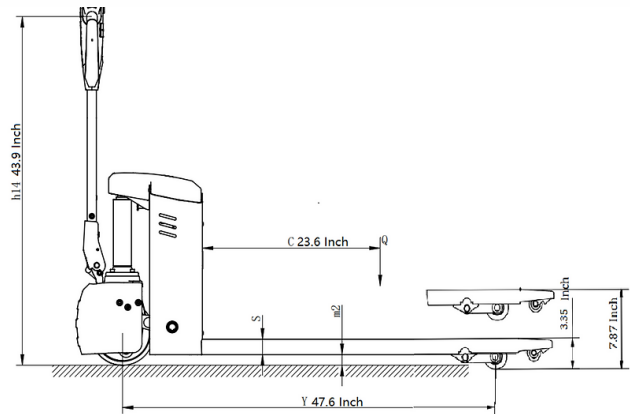

# EKKO EPF15LI LITHIUM-IRON Walkie Pallet Jack

The EKKO EPF15LI Lithium-Iron Phosphate Electric Walkie Pallet Jack is designed with the versatility of a pallet jack with full power lifting and driving capabilities. It is ideal for loading and unloading trucks, loading docks, stock rooms, manufacturing floors and warehousing.

Made from high quality steel and components with durable quality drives to withstand any terrain, usage, impact and directional changes for the use of any application with confidence and assurance.

- Load Capacity 3300 lb.
- Fork Size 27x48
- Raised Height 7.87"
- 24V/30Ah Li-Iron LiFePO4
- Pinwheel Capability
- Lowered Height 2.95"
- Polyurethane Wheels
- Ergonomic Handle and Controls
- Steel Construction
- Robotic Welding
- 3 Year Limited Warranty



Model		EPF15LI
Lift		Electric
Drive		Electric
Load capacity	(lb.)	3300
Load center	(in)	23.6
Wheelbase	(in)	51.69
Lowered fork height	(in)	2.95
Lifting height	(in)	7.87
Overall length	(in)	65.86
Overall width	(in)	26.97
Fork size	s/e/l (in)	1.97/5.9/48.03
Outside distance of fork	(in)	26.97
Turning radius	(in)	57.8
Lifting speed, laden/unladen	(in/s)	N/A
Lowering speed, laden/unladen	(in/s)	N/A
Max gradient performance laden/unladen	(%)	5/8
Brake type		electromagnetic
Drive motor	(W)	750W
Lift motor	(W)	800W
Battery voltage/rated capacity	(V/Ah)	24V/30Ah Li
DC Drive Motor		DC Motor speed control
Noise level at operator seat	(dB(A))	70
Service weight with battery	(lb.)	345

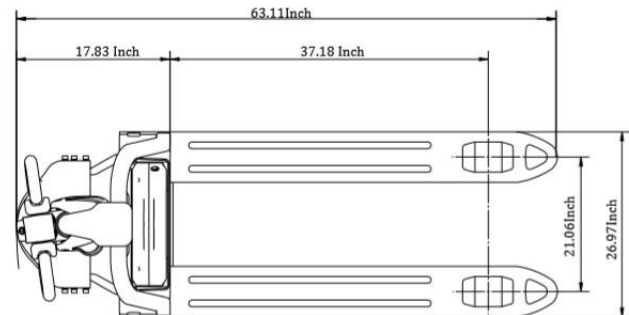
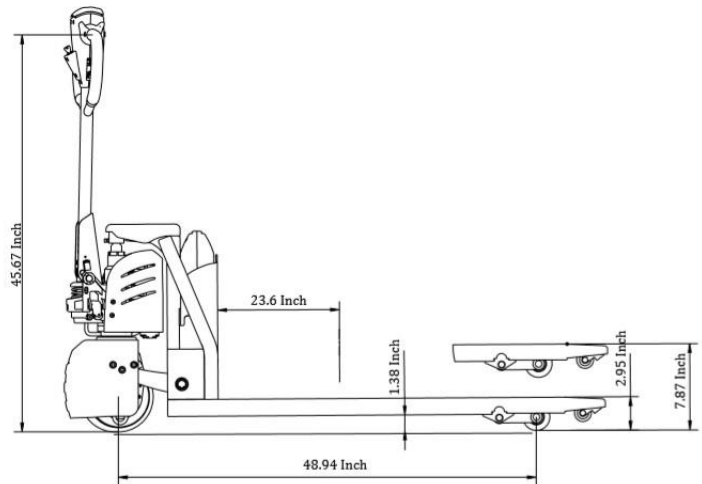

# EKKO EPF18LI LITHIUM-IRON Walkie Pallet Jack

The EKKO EPF18LI Lithium-Iron Phosphate Electric Walkie Pallet Jack is designed with the versatility of a pallet jack with full power lifting and driving capabilities. It is ideal for loading and unloading trucks, loading docks, stock rooms, manufacturing floors and warehousing.

Made from high quality steel and components with durable quality drives to withstand any terrain, usage, impact and directional changes for the use of any application with confidence and assurance.

- Load Capacity 4000 lb.
- Fork Size 27x48
- Raised Height 7.87"
- 24V/40Ah Li-Iron LiFePO4
- Pinwheel Capability
- Lowered Height 2.95"
- Polyurethane Wheels
- Ergonomic Handle and Controls
- Steel Construction
- Robotic Welding
- 3 Year Limited Warranty



Model		EPF18LI
Lift		Electric
Drive		Electric
Load capacity	(lb.)	4000
Load center	(in)	23.6
Wheelbase	(in)	51.69
Lowered fork height	(in)	2.95
Lifting height	(in)	7.87
Overall length	(in)	65.86
Overall width	(in)	26.97
Fork size	s/e/l (in)	1.97/5.9/48.03
Outside distance of fork	(in)	26.97
Turning radius	(in)	57.8
Lifting speed, laden/unladen	(in/s)	N/A
Lowering speed, laden/unladen	(in/s)	N/A
Max gradient performance laden/unladen	(%)	5/8
Brake type		electromagnetic
Drive motor	(W)	750W
Lift motor	(W)	800W
Battery voltage/rated capacity	(V/Ah)	24V/40Ah Li
DC Drive Motor		DC Motor speed control
Noise level at operator seat	(dB(A))	70
Service weight with battery	(lb.)	370

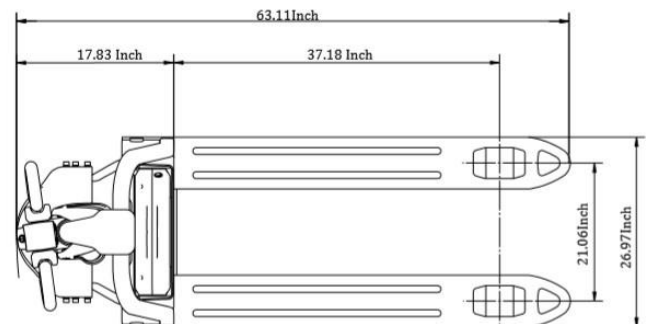
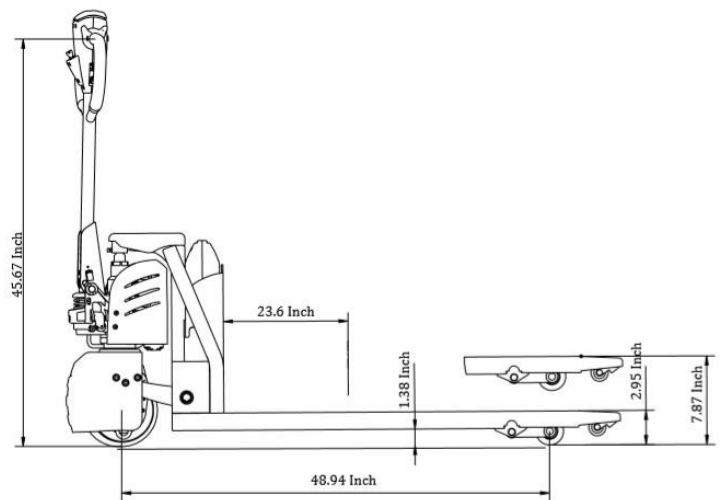

# EKKO EPF20LI LITHIUM-IRON Walkie Pallet Jack

The EKKO EPF20LI Lithium-Iron Phosphate Electric Walkie Pallet Jack is designed with the versatility of a pallet jack with full power lifting and driving capabilities. It is ideal for loading and unloading trucks, loading docks, stock rooms, manufacturing floors and warehousing.

Made from high quality steel and components with durable quality drives to withstand any terrain, usage, impact and directional changes for the use of any application with confidence and assurance.

- Load Capacity 4400 lb.
- Fork Size 27x48
- Raised Height 7.87"
- 48V/30Ah Li-Iron LiFePO4
- Pinwheel Capability
- Lowered Height 2.95"
- Polyurethane Wheels
- Ergonomic Handle and Controls
- Steel Construction
- Robotic Welding
- 3 Year Limited Warranty



Model		EPF20LI
Lift		Electric
Drive		Electric
Load capacity	(lb.)	4400
Load center	(in)	23.6
Wheelbase	(in)	51.69
Lowered fork height	(in)	2.95
Lifting height	(in)	7.87
Overall length	(in)	65.86
Overall width	(in)	26.97
Fork size	s/e/l (in)	1.97/5.9/48.03
Outside distance of fork	(in)	26.97
Turning radius	(in)	57.8
Lifting speed, laden/unladen	(in/s)	N/A
Lowering speed, laden/unladen	(in/s)	N/A
Max gradient performance laden/unladen	(%)	5/8
Brake type		electromagnetic
Drive motor	(W)	750W
Lift motor	(W)	800W
Battery voltage/rated capacity	(V/Ah)	48V/30Ah Li
DC Drive Motor		DC Motor speed control
Noise level at operator seat	(dB(A))	70
Service weight with battery	(lb.)	390

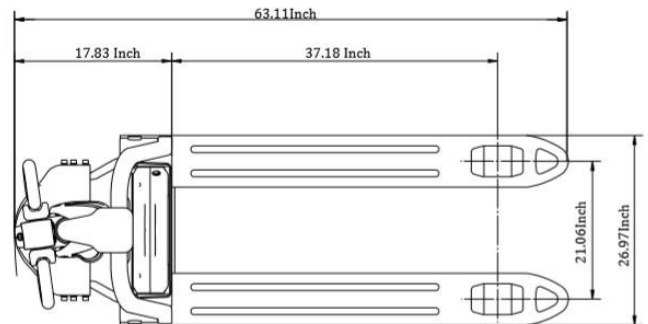
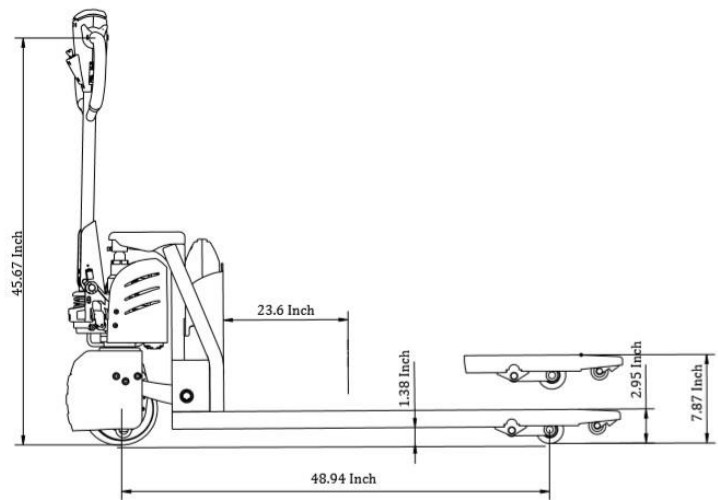

# EKKO EP15SLI LITHIUM-IRON Walkie Pallet Jack

The EKKO EP15SLI Lithium-Iron Phosphate Electric Walkie Pallet Jack is designed with the versatility of a pallet jack with full power lifting and driving capabilities. It is ideal for loading and unloading trucks, loading docks, stock rooms, manufacturing floors and warehousing.

Made from high quality steel and components with durable quality drives to withstand any terrain, usage, impact and directional changes for the use of any application with confidence and assurance.

- Load Capacity 3300 lb.
- Fork Size 27x48
- Raised Height 7.87"
- 24V/30Ah Li-Iron LiFePO4
- Pinwheel Capability
- Lowered Height 2.95"
- Polyurethane Wheels
- Ergonomic Handle and Controls
- Steel Construction
- Robotic Welding
- 3 Year Limited Warranty



Model		EP15SLI
Lift		Electric
Drive		Electric
Load capacity	(lb.)	3300
Load center	(in)	23.6
Wheelbase	(in)	51.69
Lowered fork height	(in)	3.35
Lifting height	(in)	7.87
Overall length	(in)	65.86
Overall width	(in)	26.97
Fork size	s/e/l (in)	1.97/5.9/48.03
Outside distance of fork	(in)	26.97
Turning radius	(in)	57.8
Lifting speed, laden/unladen	(in/s)	N/A
Lowering speed, laden/unladen	(in/s)	N/A
Max gradient performance laden/unladen	(%)	5/8
Brake type		electromagnetic
Drive motor	(W)	750W
Lift motor	(W)	800W
Battery voltage/rated capacity	(V/Ah)	24V/30Ah Li
DC Drive Motor		DC Motor speed control
Noise level at operator seat	(dB(A))	70
Service weight with battery	(lb.)	345

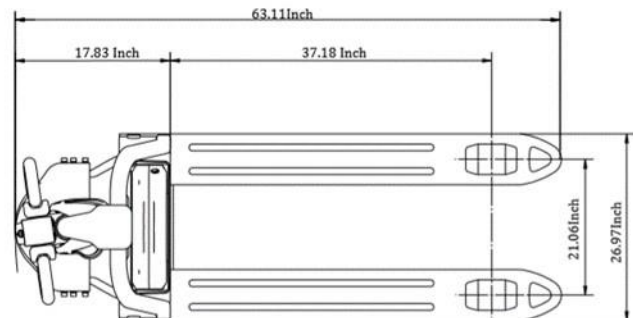
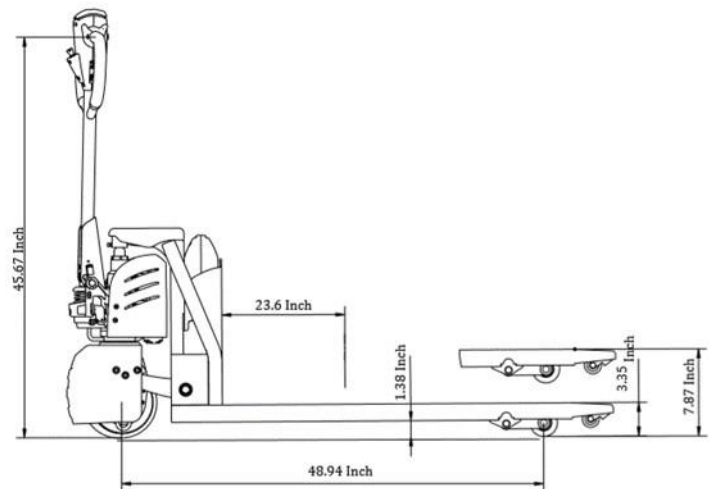

# EKKO EP18SLI LTHIUM-IRON Walkie Pallet Jack

The EKKO EP18SLI Lithium-Iron Phosphate Electric Walkie Pallet Jack is designed with the versatility of a pallet jack with full power lifting and driving capabilities. It is ideal for loading and unloading trucks, loading docks, stock rooms, manufacturing floors and warehousing.

Made from high quality steel and components with durable quality drives to withstand any terrain, usage, impact and directional changes for the use of any application with confidence and assurance.

- Load Capacity 4000 lb.
- Fork Size 27x48
- Raised Height 7.87"
- Pinwheel Capability
- 24V/40Ah Li-Iron LiFePO4
- Lowered Height 2.95"
- Polyurethane Wheels
- Ergonomic Handle and Controls
- Steel Construction
- Robotic Welding
- 3 Year Limited Warranty



Model		EP18SLI
Lift		Electric
Drive		Electric
Load capacity	(lb.)	4000
Load center	(in)	23.6
Wheelbase	(in)	51.69
Lowered fork height	(in)	3.35
Lifting height	(in)	7.87
Overall length	(in)	65.86
Overall width	(in)	26.97
Fork size	s/e/l (in)	1.97/5.9/48.03
Outside distance of fork	(in)	26.97
Turning radius	(in)	57.8
Lifting speed, laden/unladen	(in/s)	N/A
Lowering speed, laden/unladen	(in/s)	N/A
Max gradient performance laden/unladen	(%)	5/8
Brake type		electromagnetic
Drive motor	(W)	750W
Lift motor	(W)	800W
Battery voltage/rated capacity	(V/Ah)	24V/40Ah Li
DC Drive Motor		DC Motor speed control
Noise level at operator seat	(dB(A))	70
Service weight with battery	(lb.)	345

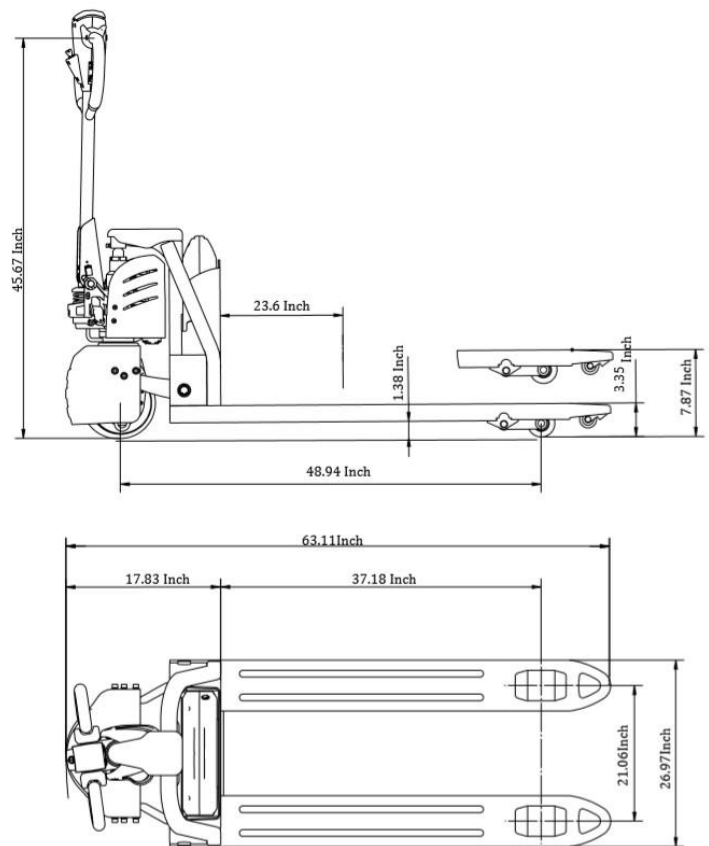

# EKKO A25S Stainless Steel Manual Pallet Jack



The EKKO A25S Stainless Steel Manual Pallet Jack is designed with quality materials, components, and workmanship. Every product is robotically welded and is reliable for loading and unloading trucks, loading docks, stock rooms, manufacturing floors and warehousing.

The Specialized Pallet Truck is ideal for sanitary, pharmaceutical, medical, food, and wet environments. Pallet Truck is one hundred percent (100%) type 304 stainless steel for long life in the harshest environments.

Made from high quality stainless steel and components with durable hydraulic pumps with quality load wheels to withstand any terrain, usage, impact and directional changes. for the use of any application with confidence and assurance.

- Stainless Steel
- Load Capacity 5500 lb.
- Fork Size 27x48
- Raised Height 7.5"
- Lowered Height 2.95"
- Galvanized Hydraulic Pumps
- Nylon Wheels
- Ergonomic Handles
- Steel Construction
- Robotic Welding
- 3 years limited Warranty.

Model		A25S
Load Capacity	(lb.)	5500
Lifting height Max.	(in)	7.5
Fork length	(in)	48
Fork width	(in)	27
Fixed leg width, single	(in)	6.3
Overall length	(in)	63"
Overall width max	(in)	27
Lowered fork height	(in)	2.95
Service Weight	(lb.)	155

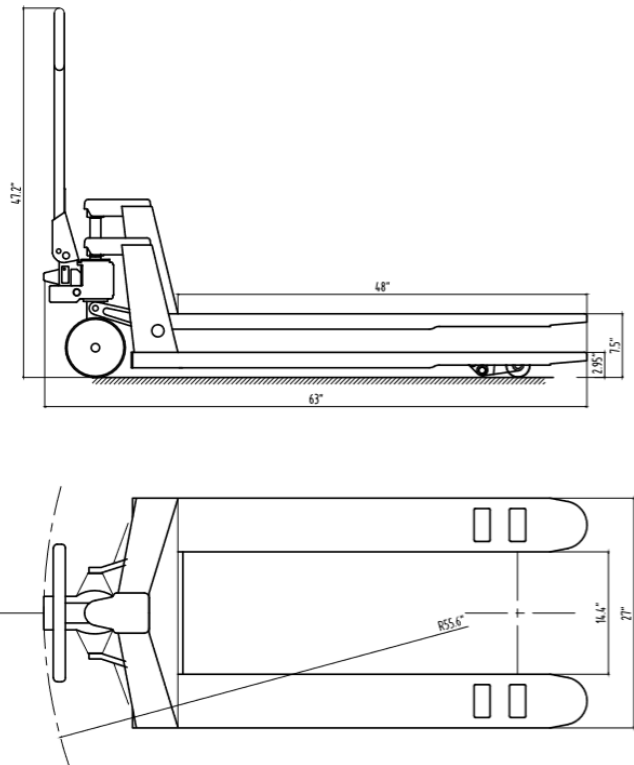



# EKKO A25 Manual Pallet Jack



The EKKO A25 Manual Pallet Jack is designed with quality materials, components and workmanship. Every product is robotically welded, powder coated and is reliable for loading and unloading trucks, loading docks, stock rooms, manufacturing floors and warehousing.

Made from high quality steel and components with durable hydraulic pumps with quality load wheels to withstand any terrain, usage, impact and directional changes. for the use of any application with confidence and assurance.

- Load Capacity 5500 lb.
- Fork Size 27x48
- Raised Height 7.5"
- Lowered Height 2.95"
- Galvanized Hydraulic Pumps
- Polyurethane Wheels
- Ergonomic Handles
- Powder Coated
- Steel Construction
- Robotic Welding
- 3 Year Limited Warranty

Model		A25
Load Capacity	(lb.)	5500
Lifting height Max.	(in)	7.5
Fork length	(in)	48
Fork width	(in)	27
Fixed leg width, single	(in)	6.3
Overall length	(in)	63"
Overall width max	(in)	27
Lowered fork height	(in)	2.95
Service Weight	(lb.)	160

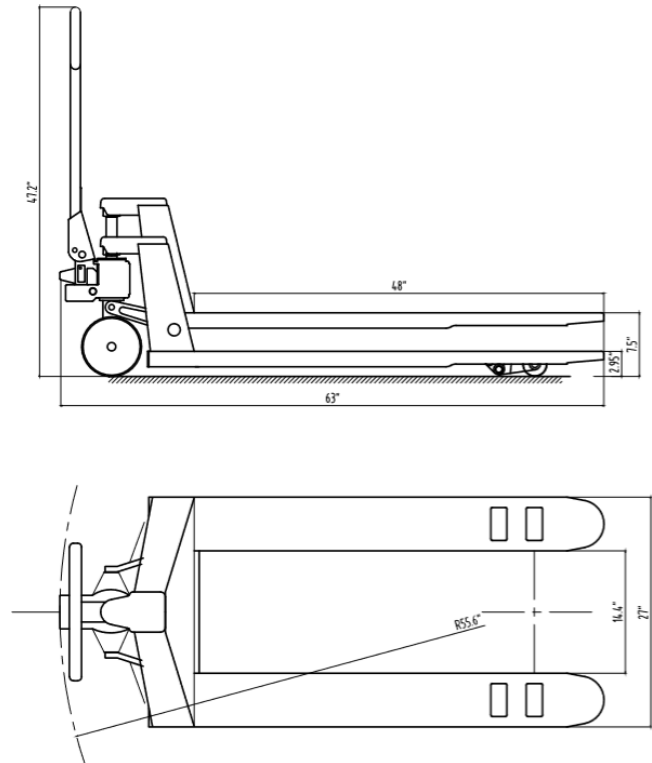

## EKKO ES40E Scissor Lift Aerial Platform

The EKKO ES40E Scissor Aerial Work Platform is a 506-lb capacity compact platform with four wheels and curts controller which allows you to make lifting, transporting loads, and moving products easily and safely. This product also complies with GB25849 and EN280 standards.

- Load Capacity 500 lb.
- Raised Height 13.1' (157.5")
- Lowered Height 77"
- Size: Length 50.4" x Width 29.1"
- Steel construction
- 3 Years Limited Warranty

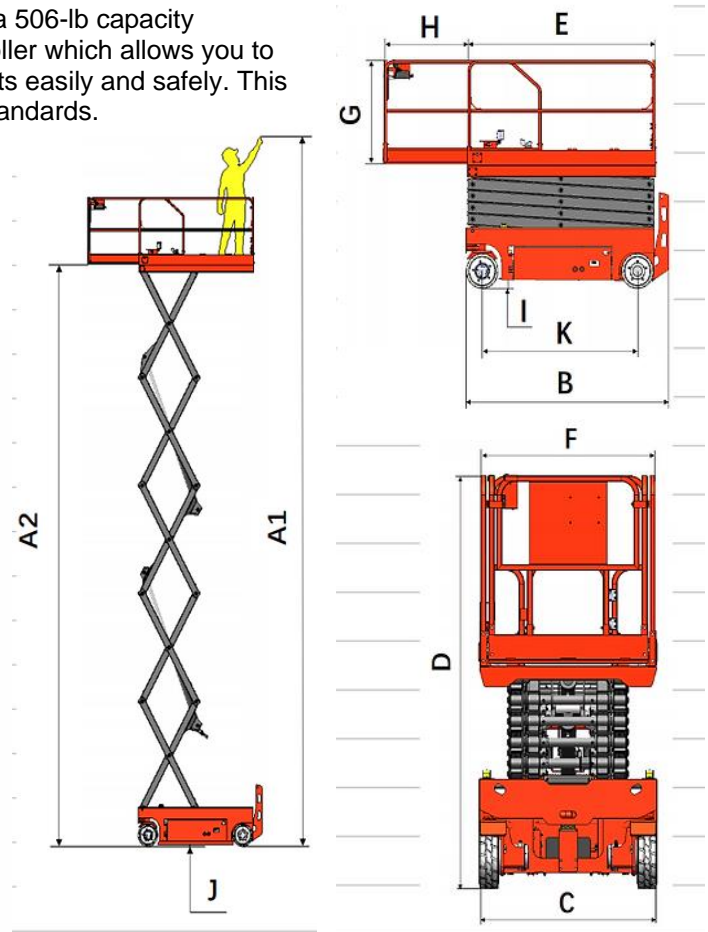

Model		ES40E
Load Capacity	(lb.)	500
Maximum Number of Workers (indoor/outdoor)		2/-
Lifting height Max.	(in)	157.5(13.1')
Length X Width	(in)	50.4 x 29.1
Platform Extension Size	(in)	23.6
Max Working Height	(in)	236.2(19.6')
Lowered height	(in)	76.8(6.4')
Guardrail height	(in)	43.31
Driving Speed (Lifted state/lowered state)	(km/h)	0-0.8/0-4
Rise/fall time	(S)	25/25
Battery	(V/Ah)	12x2V/100Ah
Charger	VAC	100-240
Service Weight	(lb.)	2050

## EKKO ES60E Scissor Lift Aerial Platform

The EKKO ES60E Scissor Aerial Work Platform is a 506-lb capacity compact platform with four wheels and curts controller which allows you to make lifting, transporting loads, and moving products easily and safely. This product also complies with GB25849 and EN280 standards.

- Load Capacity 500 lb.
- Raised Height 19' (228")
- Lowered Height 86"
- Size: Length 65" x Width 30"
- Steel construction
- 3 Years Limited Warranty

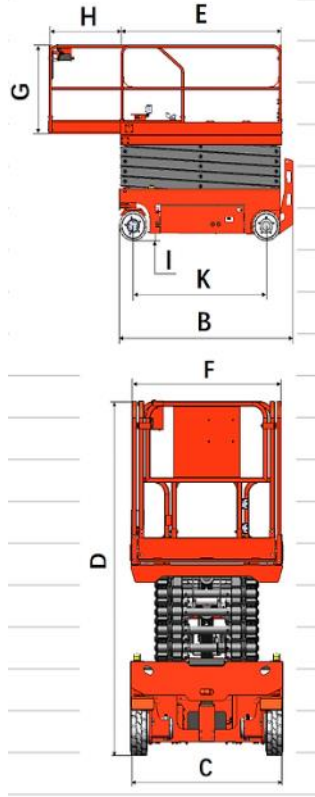
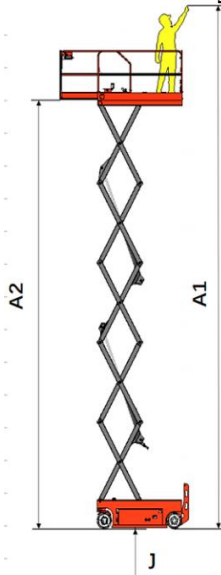

Model		ES60E
Load Capacity	(lb.)	500
Maximum Number of Workers (indoor/outdoor)		2/-
Lifting height Max.	(in)	228" (19')
Length X Width	(in)	72.44x29.92
Platform Extension Size	(in)	35.43
Max Working Height	(in)	307" (25.6')
Lowered height	(in)	86" (7.2')
Guardrail height	(in)	43.31
Driving Speed (Lifted state/lowered state)	(km/h)	0-0.8/0-4
Rise/fall time	(S)	18/28
Battery	(V/Ah)	6x4V/180Ah
Charger	VAC	100-240
Service Weight	(lb.)	3256

## EKKO ES80E Scissor Lift Aerial Platform

The EKKO ES80E Scissor Aerial Work Platform is a 990-lb capacity compact platform with four wheels and curtis controller which allows you to make lifting, transporting loads, and moving products easily and safely. This product also complies with GB25849 and EN280 standards.

- Load Capacity 990 lb.
- Raised Height 26.2' (315")
- Lowered Height 90.6"
- Size: Length 89" x Width 45"
- Steel construction
- 3 Years Limited Warranty

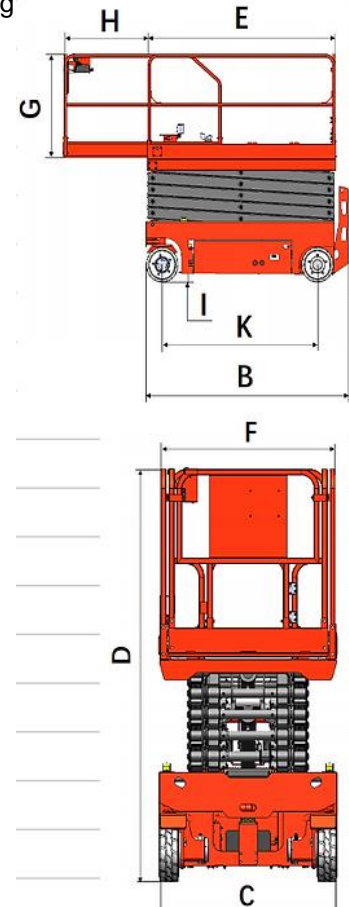
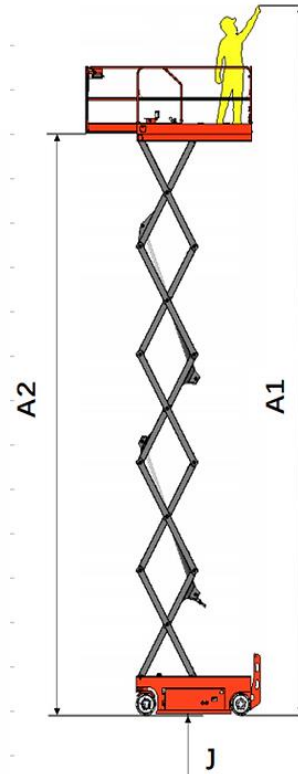

Model		ES80E
Load Capacity	(lb.)	990
Maximum Number of Workers (indoor/outdoor)		2/1
Lifting height Max.	(in)	315" (26.2')
Length/Width	(in)	94.5/45.27
Platform Extension Size	(in)	39.37
Max Working Height	(in)	394" (32.8')
Lowered height	(in)	90.6"(7.5')
Guardrail height	(in)	43.3
Driving Speed (Lifted state/lowered state)	(km/h)	0-0.8/0-3.2
Rise/fall time	(s)	32/35
Battery	(V/Ah)	6x4V/180Ah
Charger	VAC	100-240
Service Weight	(lb.)	5412

## EKKO ES100E Scissor Lift Aerial Platform

The EKKO ES100E Scissor Aerial Work Platform is a 700-lb capacity compact platform with four wheels and curbs controller which allows you to make lifting, transporting loads, and moving products easily and safely. This product also complies with GB25849 and EN280 standards.



- Load Capacity 700 lb.
- Raised Height 32.8' (394")
- Lowered Height 96.85"
- Size: Length 89" x Width 45"
- Steel construction
- 3 Years Limited Warranty

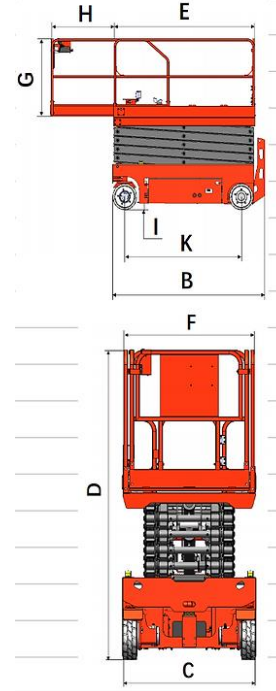

Model		ES100E
Load Capacity	(lb.)	700
Maximum Number of Workers (indoor/outdoor)		2/1
Lifting height Max.	(in)	394" (32.9')
Length/Width	(in)	94.5/45.27
Platform Extension Size	(in)	39.37
Max Working Height	(in)	472" (39.3')
Lowered height	(in)	96.85" (8')
Guardrail height	(in)	43.3
Driving Speed (Lifted state/lowered state)	(km/h)	0-0.8/0-3.2
Rise/fall time	(S)	52/48
Battery	(V/Ah)	6x4V/180Ah
Charger	VAC	100-240
Service Weight	(lb.)	6204

## EKKO ES120E Scissor Lift Aerial Platform

The EKKO ES120E Scissor Aerial Work Platform is a 700-lb capacity compact platform with four wheels and Curtis controller which allows you to make lifting, transporting loads, and moving products easily and safely. This product also complies with GB25849 and EN280 standards.

- Load Capacity 700 lb.
- Raised Height 39' (468")
- Lowered Height 102.36"
- Size: Length 89" x Width 45"
- Steel construction
- 3 Years Limited Warranty

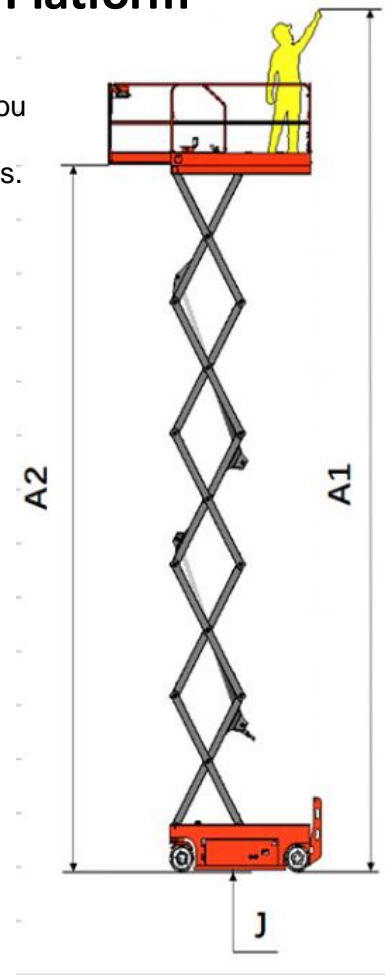
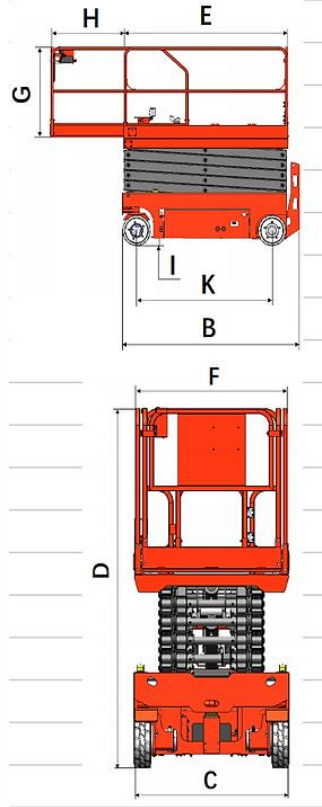

Model		ES120E
Load Capacity	(lb.)	700
Maximum Number of Workers (indoor/outdoor)		2/-
Lifting height Max.	(in)	468' (39')
Length/Width	(in)	94.5/45.27
Platform Extension Size	(in)	39.37
Max Working Height	(in)	547" (45.6')
Lowered height	(in)	102.36"(8.5')
Guardrail height	(in)	43.3
Driving Speed (Lifted state/lowered state)	(km/h)	0-0.8/0-3.2
Rise/fall time	(s)	52/52
Battery	(V/Ah)	6x4V/240Ah
Charger	VAC	100-240
Service Weight	(lb.)	6490

## ES40E-Li Lithium Scissor Lift Aerial Platform

The EKKO ES40E-LI Scissor Aerial Work Platform is a 506-lb capacity compact platform with four wheels and Curtis controller which allows you to make lifting, transporting loads, and moving products easily and safely. This product also complies with GB25849 and EN280 standards.

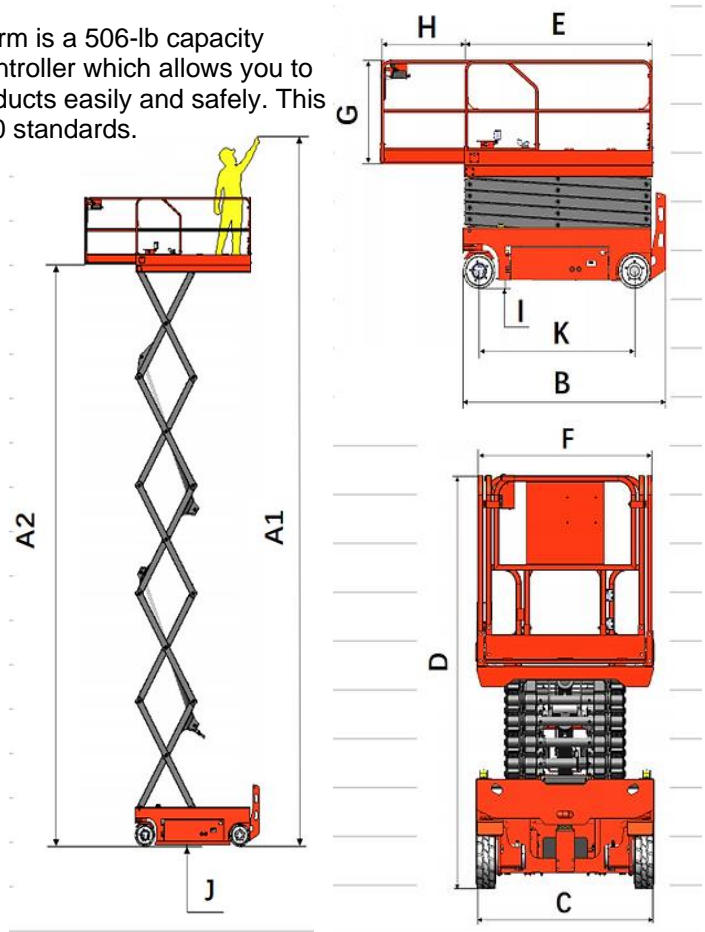

Model		ES40E-LI
Load Capacity	(lb.)	500
Maximum Number of Workers (indoor/outdoor)		2/-
Lifting height Max.	(in)	157.5(13.1')
Length X Width	(in)	50.4 x 29.1
Platform Extension Size	(in)	23.6
Max Working Height	(in)	236.2(19.6')
Lowered height	(in)	76.8(6.4')
Guardrail height	(in)	43.31
Driving Speed (Lifted state/lowered state)	(km/h)	0-0.8/0-4
Rise/fall time	(S)	25/25
Battery	(V/Ah)	25.6V/150AH Lithium
Charger output	A	36A
Service Weight	(lb.)	2250

## EKKO ES60E-LI Scissor Lift Aerial Platform

The EKKO ES60E-LI Scissor Aerial Work Platform is a 506-lb capacity compact platform with four wheels and Curtis controller which allows you to make lifting, transporting loads, and moving products easily and safely. This product also complies with GB25849 and EN280 standards.

- Load Capacity 500 lb.
- Raised Height 19' (228")
- Lowered Height 86"
- Size: Length 65" x Width 30"
- Steel construction
- 3 Years Limited Warranty

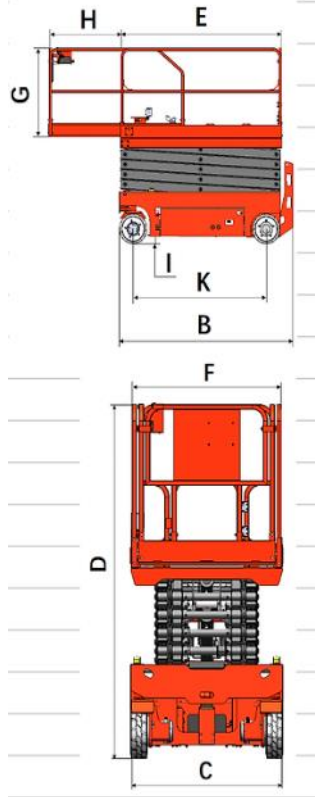
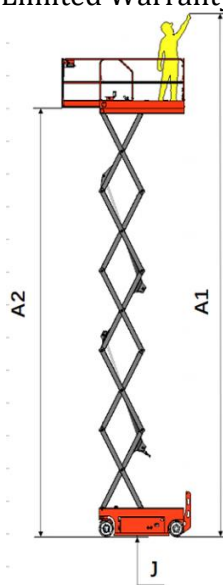

Model		ES60E-LI
Load Capacity	(lb.)	500
Maximum Number of Workers (indoor/outdoor)		2/-
Lifting height Max.	(in)	228" (19')
Length X Width	(in)	72.44x29.92
Platform Extension Size	(in)	35.43
Max Working Height	(in)	307" (25.6')
Lowered height	(in)	86" (7.2')
Guardrail height	(in)	43.31
Driving Speed (Lifted state/lowered state)	(km/h)	0-0.8/0-4
Rise/fall time	(S)	18/28
Battery	(V/Ah)	25.6V/150AH Lithium
Charger	A	36A
Service Weight	(lb.)	3356



## EKKO ES80E-Li Scissor Lift Aerial Platform

The EKKO ES80E-Li Scissor Aerial Work Platform is a 990-lb capacity compact platform with four wheels and Curtis controller which allows you to make lifting, transporting loads, and moving products easily and safely. This product also complies with GB25849 and EN280 standards.

- Load Capacity 990 lb.
- Raised Height 26.2' (315")
- Lowered Height 90.6"
- Size: Length 89" x Width 45"
- Steel construction
- 3 Years Limited Warranty

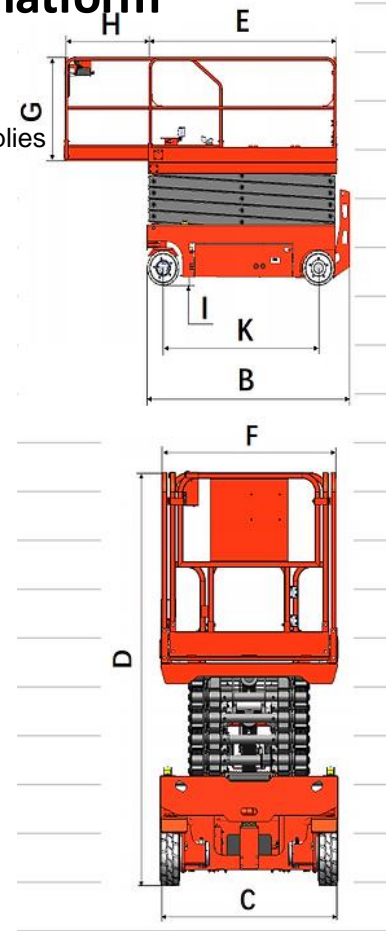
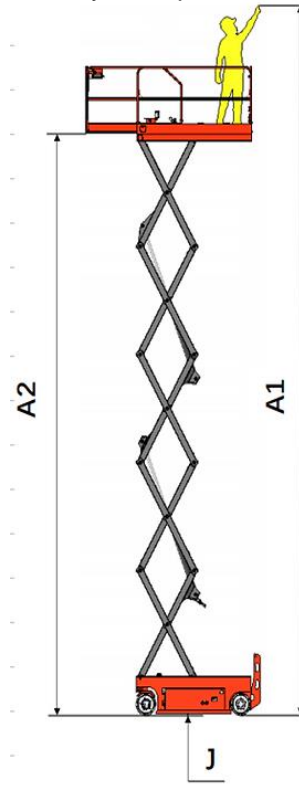

Model		ES80E-Li
Load Capacity	(lb.)	990
Maximum Number of Workers (indoor/outdoor)		2/1
Lifting height Max.	(in)	315" (26.2')
Length/Width	(in)	94.5/45.27
Platform Extension Size	(in)	39.37
Max Working Height	(in)	394" (32.8')
Lowered height	(in)	90.6" (7.5')
Guardrail height	(in)	43.3
Driving Speed (Lifted state/lowered state)	(km/h)	0-0.8/0-3.2
Rise/fall time	(s)	32/35
Battery	(V/Ah)	25.6V/230AH Lithium
Charger	A	36A
Service Weight	(lb.)	5512

## EKKO ES100E-Li Scissor Lift Aerial Platform

The EKKO ES100E-Li Scissor Aerial Work Platform is a 700-lb capacity compact platform with four wheels and Curtis controller which allows you to make lifting, transporting loads, and moving products easily and safely. This product also complies with GB25849 and EN280 standards.



- Load Capacity 700 lb.
- Raised Height 32.8' (394")
- Lowered Height 96.85"
- Size: Length 89" x Width 45"
- Steel construction
- 3 Years Limited Warranty

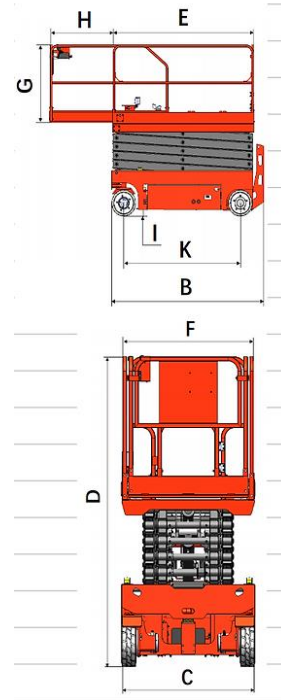

Model		ES100E-Li
Load Capacity	(lb.)	700
Maximum Number of Workers (indoor/outdoor)		2/1
Lifting height Max.	(in)	394" (32.9')
Length/Width	(in)	94.5/45.27
Platform Extension Size	(in)	39.37
Max Working Height	(in)	472" (39.3')
Lowered height	(in)	96.85" (8')
Guardrail height	(in)	43.3
Driving Speed (Lifted state/lowered state)	(km/h)	0-0.8/0-3.2
Rise/fall time	(S)	52/48
Battery	(V/Ah)	25.6V/230AH Lithium
Charger	A	36A
Service Weight	(lb.)	6304

## EKKO ES120E-LI Scissor Lift Aerial Platform

The EKKO ES120E-LI Scissor Aerial Work Platform is a 700-lb capacity compact platform with four wheels and Curtis controller which allows you to make lifting, transporting loads, and moving products easily and safely. This product also complies with GB25849 and EN280 standards.

- Load Capacity 700 lb.
- Raised Height 39' (468")
- Lowered Height 102.36"
- Size: Length 89" x Width 45"
- Steel construction
- 3 Years Limited Warranty

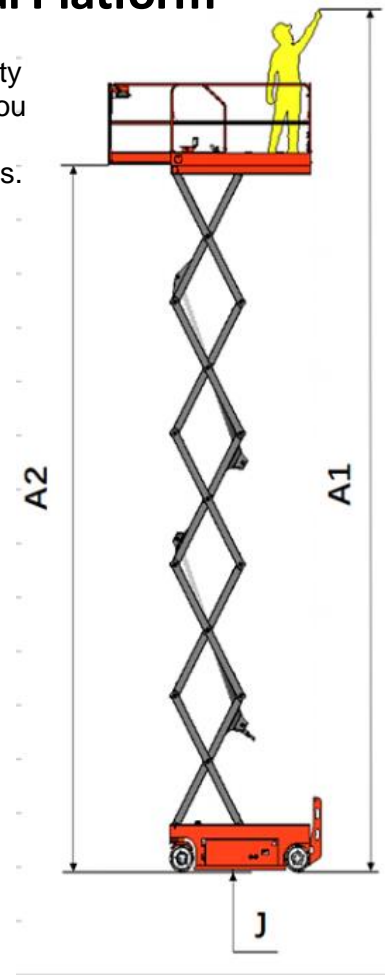
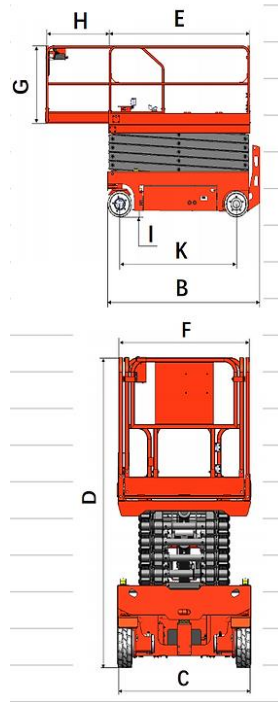

Model		ES120E-LI
Load Capacity	(lb.)	700
Maximum Number of Workers (indoor/outdoor)		2/-
Lifting height Max.	(in)	468' (39')
Length/Width	(in)	94.5/45.27
Platform Extension Size	(in)	39.37
Max Working Height	(in)	547" (45.6')
Lowered height	(in)	102.36" (8.5')
Guardrail height	(in)	43.3
Driving Speed (Lifted state/lowered state)	(km/h)	0-0.8/0-3.2
Rise/fall time	(S)	52/52
Battery	(V/Ah)	25.6V/230AH Lithium
Charger	A	36A
Service Weight	(lb.)	6590

## EKKO T15 Scissor Lift Table Cart

The EKKO T15 Scissor Lift Table Cart is a compact cart to make lifting, transporting loads, order-picking, and moving products with ease. An ergonomic solution to lifting, positioning and transporting goods.

Our scissor carts are made of heavy-duty steel and constructed to hold up for longevity. Two polyurethane front casters and two rear swivel casters with built-in hand release and foot pump.

- Load Capacity 330 lb.
- Raised Height 28.3"
- Lowered Height 8.3"
- Size Length 27.5" x Width 17.7"
- Polyurethane Casters
- Hand Release
- Foot Brake
- Steel construction
- Robotic Welding
- 3 Years Limited Warranty



Model		T15
Load Capacity	(lb.)	330
Lifting height Max.	(in)	28.3
Length	(in)	27.5
Width	(in)	17.1
Lowest height	(in)	8.3
Handle height	(in)	31.89
Service Weight	(lb.)	88

# EKKO EG30 Tow Tractor

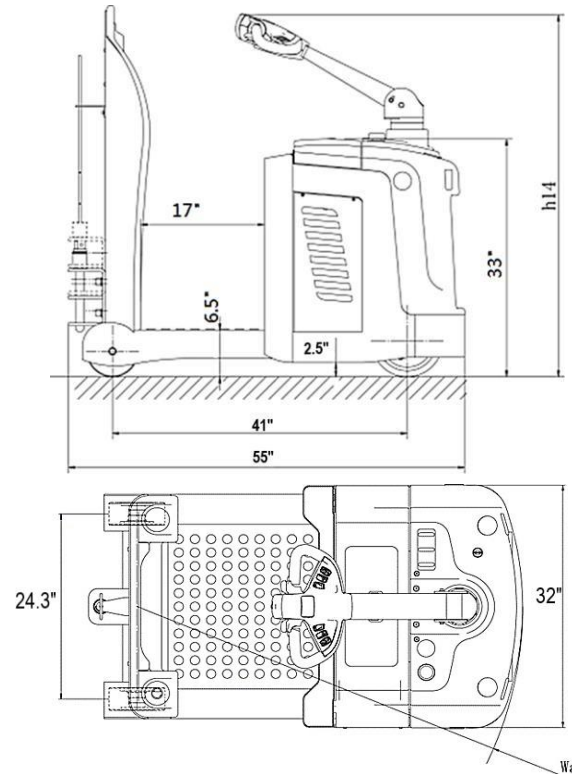

The EKKO EG30 Tow Tractor is designed for tugging and pulling applications made with quality materials, components and workmanship. Every product is robotically welded, powder coated and is reliable for loading and unloading trucks, loading docks, stock rooms, manufacturing floors and warehousing.

Made from high quality steel and components to withstand any terrain, usage, impact and directional changes for the use of any application with confidence and assurance.

- Tow Capacity 10,000 lb.
- Curtis Instrument Controller
- AC Drive 1.3
- Standing Drive
- Polyurethane Wheels
- EPS (Electronic Power Steering)
- Ergonomic Handle and Controls
- Steel Construction
- Robotic Welding
- 24V/210Ah
- 3 Year Limited Warranty

Model		EG30
Power unit		Electric
Operation		Standing
Tow Weight	(lb.)	10,000
Overall length	(in)	55
Overall width	(in)	32
Overall, Height	(in)	53
Turning radius	(in)	49
Max gradient performance laden/unladen	(%)	3/15
AC Drive motor	(W)	1300W
Battery voltage/rated capacity	(V/Ah)	24V/210Ah
AC Drive Motor		AC Motor speed control
Noise level at operator seat	(dB(A))	68
Service weight (w/ battery)	(lb.)	1445

# **EKKO**<sup>®</sup>

## **MATERIAL HANDLING EQUIPMENT**



**EKKO Material Handling Equipment Mfg. Inc.**  
**1761 W. Holt Ave. Pomona, CA.**  
**91768**

**T: (877) 232-6517**

**O: (909) 222-6529**

**F: (909) 222-6861**

**info@ekkolifts.com**

**www.ekkolifts.com**