

EKKO[®]

MATERIAL HANDLING EQUIPMENT

MOVING AHEAD

SPECIFICATION

Counter Balanced Electric Forklift

EK18RF / EK18RF-Li / EK18RFL



Introduction

In order to meet the needs of the national environmental protection request, To reduce industrial pollution and improve productivity, we develop new series of EK18RF & EK18RFL Type Counter Balanced Electric Forklift . on the basis of absorption of the advantages of domestic & overseas battery truck, they are especially suitable for cargo loading and unloading, handling, stacking, etc. for food, bank, light textile, station, port, logistics and other enterprises.

This forklift uses advanced structures such as wide-view door frame system, EPS steering system, new AC controller, open-type light guard, and is equipped with high-quality motors, traction batteries and high-power pump station motors. Therefore, it has the characteristics of superior performance, convenient operation, wide vision, flexible steering, reliable braking, good power, low noise, no pollution, and beautiful appearance.

This manual describes the technical parameters of the Electric Forklift, working principle and operation, maintenance, and other aspects. It can help operators use the truck more reasonable, make its maximum effect.

It is hoped that Operator strictly abide the regulations and the precautions in this manual when using the truck .Carefully use them so that your truck can be in the best working condition for long period of time to maximize its effectiveness. And create better economic benefits.

The Statement

Our company production model EK18RF & EK18RFL Type 3960LBS Counter Balanced Electric Forklift is a special motor vehicle used in factory ,tourist attractions ,amusement places which is specified by “special equipment safety supervision regulations” .

Contents

1.The General Introduction.....	1
2.Proper usage	2
3.Introduction of the product.....	4
3.1 Overview of main components.....	4
3.2 Model Overview	4
3.3 Truck schematic diagrame & Model parameters	5
4.Operating Mechanism diagram	7
5.Operating principle	8
5.1 Operation handle diagram	8
5.2 Start, Traveling and stop.....	8
5.3 Lifting & Lowering.....	9
5.4 Fork shift left & right	10
5.5 Fork tilt forward & backward	10
5.6 Steering	10
5.7 Emergency situations	11
5.8 The use of Horn and reversing Horn	11
5.9 Monitor	11
5.10 Operation	12
6.Electrical Schematic diagram.....	13

7.Hydraulic Schematic diagram	14
8、 Maintenance and care instructions.....	15
8.1 Repair and Maintenance	15
8.2. Routine Maintenance	16
8.3 Professtional Maintenance Manual	16
8.4Battery maintenance, charging and maintenance	19
9.Safety Caution.....	28
9.1 General rule	28
9.2 Storage and transportation	28
9.3 Check before using.....	29
9.4Safety operation regulation.....	29
10.Service Manual.....	33
10.1 Troubleshooting	33
10.2 Preparation before repair	34
10.3 Check the amount of hydraulic oil	34
11.4 Complete repair,the preparation before using	34
11.After-sales service	35

1.The General Introduction

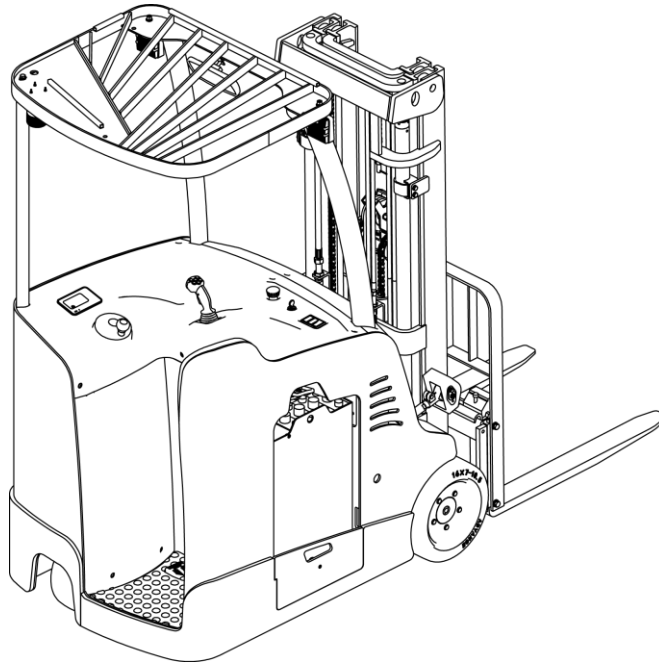

EK18RF & EK18RFL Type Counter Balanced Electric Forklift uses a battery as the power source and AC motor as power to drive the truck through gear transmission, The lifting of the fork and tilt forward & backward is driven by the AC motor hydraulic drive to push the cylinder to lift and lower the cargo, Tilt the cargo forward & backward and side shift . As the truck Electric motor for Lifting and Driving .Then it has the characteristics of labor saving, high efficiency, stable cargo operation, simple operation, safety and reliability, low noise and no pollution.

The biggest advantage of the Counter balanced Electric Forklift is that it adopted the optimized designed of wide view door frame, the mast and the hose pulley group are more compact; it is not easy to block the operator's sight, the opening size of the fork frame is enlarged, and the view is wide. The large-arc roof guard and the optimal angle grid increase the driver's upper vision. The arrangement of the right-mounted joystick fully reflects the ergonomics, improves the comfort of operation, and reduces the labor intensity of the operators.

The service environment:

- a. Altitude does not exceed 3937 ft;
- b. Indoor room temperature at +5°C to +40°C ;

c. When environment temperature at +40°C, the relative humidity can't over 50%, at low temperature, allow bigger relative humidity

d. Firm, Flat ground .

e. It is forbidden to use this car in corrosive environment such as flammable and explosive or acid base

2. Proper use

Please using the Counter Balanced Electric Forklift according to this specification.

This is a stand on type Counter Balanced Electric Forklift With solenoid valve to control truck lifting & lowering, Tilt forward and backward, and side shift

Improper use can cause personal injury or machine damage. Operators or operating companies need to ensure proper using,

The Truck needs to be used on a firm, flat, intact surface and suitable surface the truck is designed for indoor use at room temperature from +5°C to +40°C

Use under light load without using permanent barriers or pits, it is forbidden to operate on the slopes. During Operation, the goods must be placed approximately at the center of the truck's load center

Lifting or Carrying people is strictly prohibited, if carried goods. The goods must fall on the lifting point .

It is prohibited to use this truck on lifting or loading ramps.

The rated capacity is marked on the capacity label or nameplate. And the operator must pay attention to the warning signs and safety instructions.

Operating lighting must be at least 50LUX

Modification

Any modification that may affect the truck rated capacity, stability, or safety operations must be approved in advance by the Truck's original manufacturer or Its authorized Manufacturer or its successor. This includes the effects of changes such as Braking, steering, Visibility, and the addition of removable accessories.

After the manufacturer or its successor approves the modification or change ,the capacity name plate ,Label, identification marks, operation and maintenance manual must be changed accordingly

Truck damage caused by not following Instruction will lose its warranty.

3.Introduce of the product

3.1 Overview of main components

The walking of the forklift is powered by the battery, and the DC power is converted into AC power by the frequency conversion system, which is realized by controlling the AC motor on the driving wheel. The AC motor converts high-speed and low-torque into low-speed and high-torque through a gear reducer, and finally the drive wheels perform actions. The speed of walking is realized by the frequency conversion control of the motor speed, which is controlled by the operating handle.

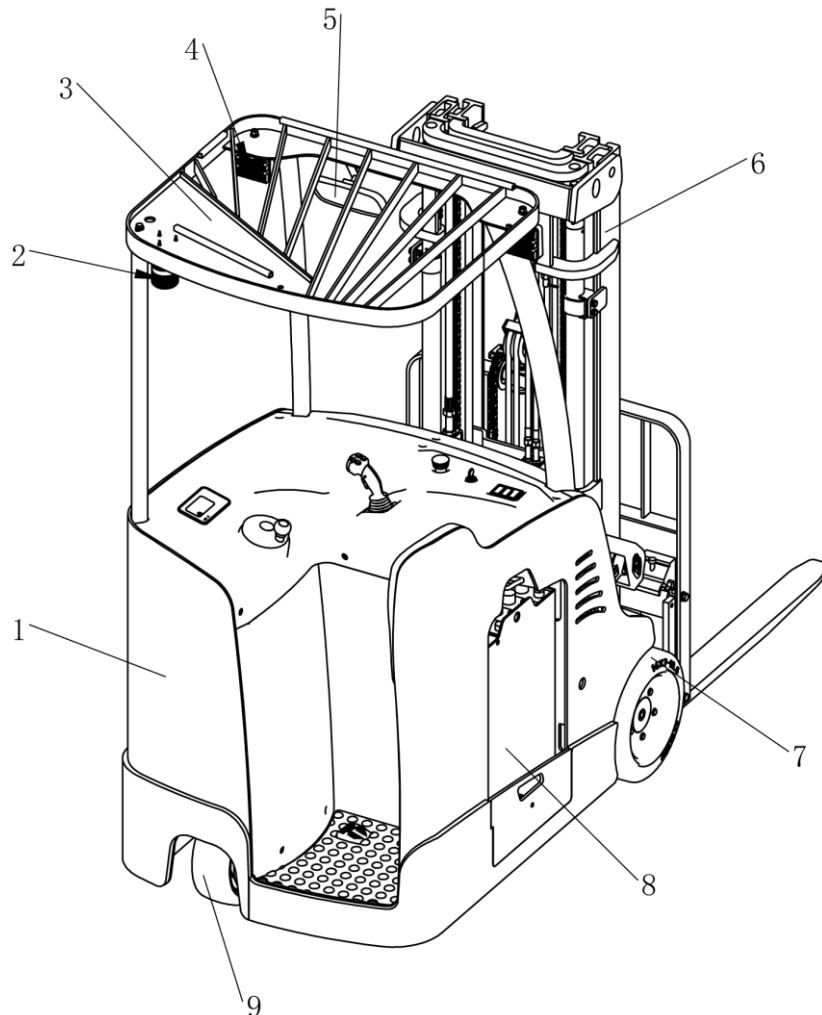

- | | | | |
|--------------------|--------------------------|------------------|-------------|
| 1.Main frame | 2.Rotating warning light | 3.Overhead guard | 4.Headlight |
| 5.Rearview mirror | 6.Door frame | 7.Front wheel | 8.Battery |
| 9.Driving assembly | | | |

3.2 Model overview

This manual brings together the EK18RF & EK18RFL 3960lbs counterbalanced Electric forklift (hereinafter referred to as "forklift").

The forklift model "EK18RF & EK18RFL-18 with a rated load of 3960lbs" meets the requirements of JB/T8452-1996 "Battery Forklift Model Preparation Method", and "RF" is the product code.

3.3 Truck schematic diagram & Model parameters

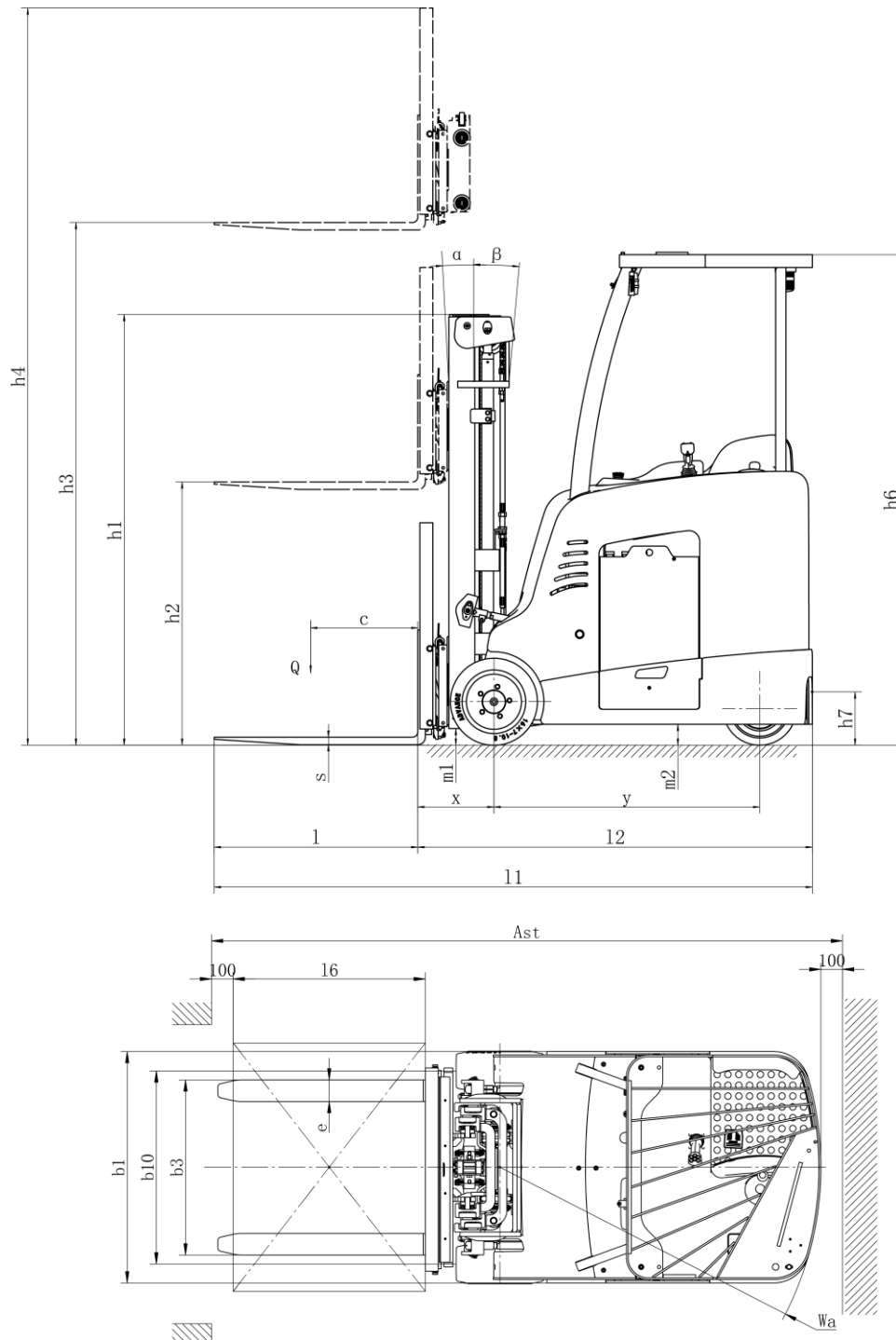

Model		EK18RFL	EK18RF
Power unit		Electric	Electric
Operation Type		Rider	Rider
Loading capacity	Q (lbs)	3960	3960
Load centre	c (Inch)	19.68	19.68
Axle centre to fork face	x (Inch)	11.5	11.5
Wheel base	y (Inch)	48.8	48.8
Service weight with battery	lbs	7870	7940
Wheels type		Solid wheel	Solid wheel
Front wheel size	Φ×w(Inch)	16×7-10.5	16×7-10.5
Rear wheel size	Φ×w(Inch)	13.5×5.2	13.5×5.2
Wheels, number front/rear (x =		1×/2	1×/2
Track width	b10 (Inch)	35.04	35.04
Mast/Fork carriage	a/b (°)	3/5	3/5
Lowered mast height	h1 (Inch)	82.6	91.77
Free lift height	h2 (Inch)	52.17	61.34
Lift height	h3 (Inch)	188.98	216.54
Extended mast height	h4 (Inch)	220.87	248.43
Height of overhead guard	h6 (Inch)	90.08	90.08
Height of seat/stand-on	h7 (Inch)	9.06	9.06
Overall length	l1 (Inch)	117.78	117.78
Length to fork face	l2 (Inch)	72.52	72.52
Overall width	b1/ b2 (Inch)	42.52/42.13	42.52/42.13
Fork dimensions	s/e/l (Inch)	1.58/4.72/45.28	1.58/4.72/45.28
Width of forks	b3 (Inch)	36.22	36.22
Ground clearance under mast	m1 (Inch)	2.95	2.95
Min.Ground clearance	m2 (Inch)	3.86	3.86
Aisle width with pallet 39.37*47.24 across forks	Ast (Inch)	117.24	117.24
Aisle width with pallet 31.5 x 47.24 along forks	Ast (Inch)	125.12	125.12
Min.Turning radius	Wa (Inch)	58.5	58.5
Travel speed.laden/unladen	(km/h)	12/13	12/13
Lifting speed, with/without load	(mm/s)	250/400	250/400
Lowering speed, with/without	(mm/s)	240/258	240/258
Climbing ability, with/without	(%)	6/10	6/10
Service brake		Electromagnetic	Electromagnetic
Drive motor, 60 minute rating	(kW)	6	6
Lift motor rating at S3 15%	(kW)	7.7	7.7
Battery according to DIN		no	no
Battery voltage/rated capacity	(V/Ah)	48/420	48/420
Battery weight (± 5%)	(LBS)	1570	1570
Power consumption according		38*18.1*29.53	38*18.1*29.53
Type of drive control		AC	AC
Noise level at operator's ear	(dB(A))	≤70	≤70

4.Operating Mechanism diagram

The Truck with battery as power producer and Use electric and hydraulic pressure to control, realize walking, fork lifting lowering, mast tilting, forward & backward and other actions. Schematic diagram of operating mechanism:

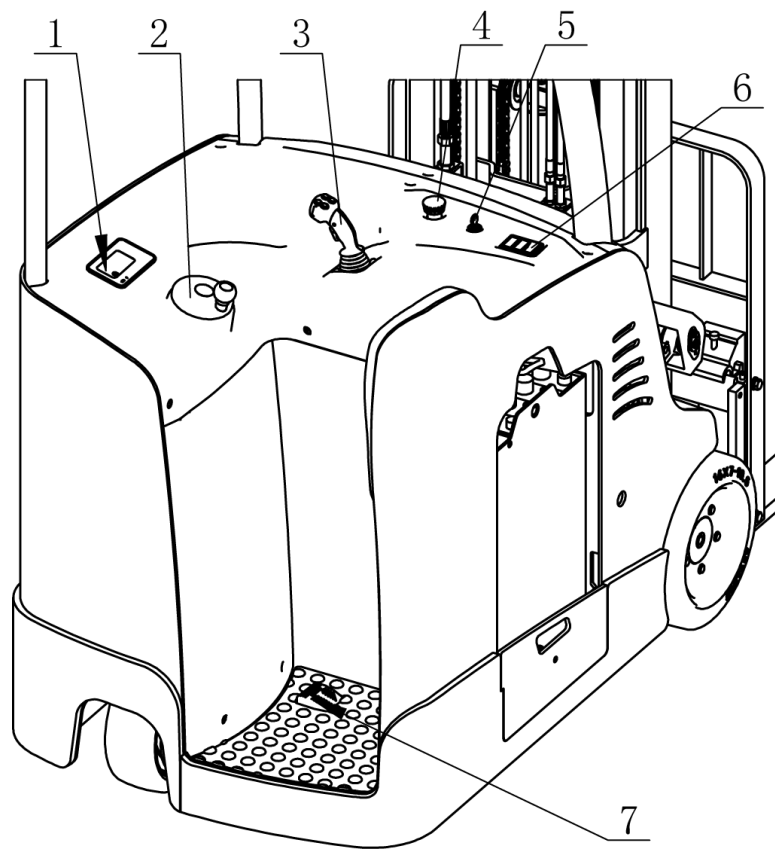

1.Instrument handle
6.Switch group

2.Steering wheel
4.Emergency stop switch
7.Foot switch

3.Grip type operating
5.Key switch

5. Operating principle

Please familiarize yourself with the functions of the switches/buttons on the dashboard before operating the forklift.

5.1 Operation handle diagram

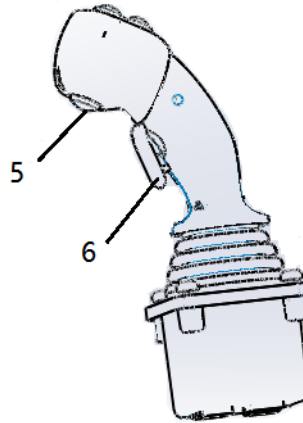
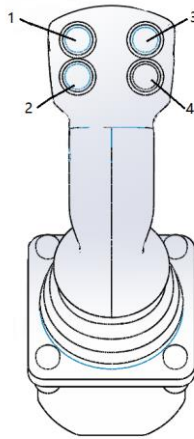

1. Tilt Forward button

2. Tilt backward button

3. Left shifter button

4. Right Shifter button

5. Horn button

6. Safety switch button

5.2 Start, Traveling and stop

Insert the key into the key switch, turn it to the right, and turn the emergency stop switch in the direction indicated by the arrow above the button to bounce, and the control circuit is opened. Slowly depress the foot switch. Rotate the steering wheel in the required direction (forward or backward). Hold the handle lever (must hold down the safety switch) and move to the B direction, and the forklift will move forward. Hold the handle lever (must hold down the safety switch) to the F direction, and the forklift will move backwards. Observe the road surface and adjust the driving speed through the handlebar. When the forklift stops, slowly pull the handle lever to the middle of position and leave the foot switch with your right foot to stop the forklift completely. Put the fork to the lowest position, press the safety switch, and pull out the key.

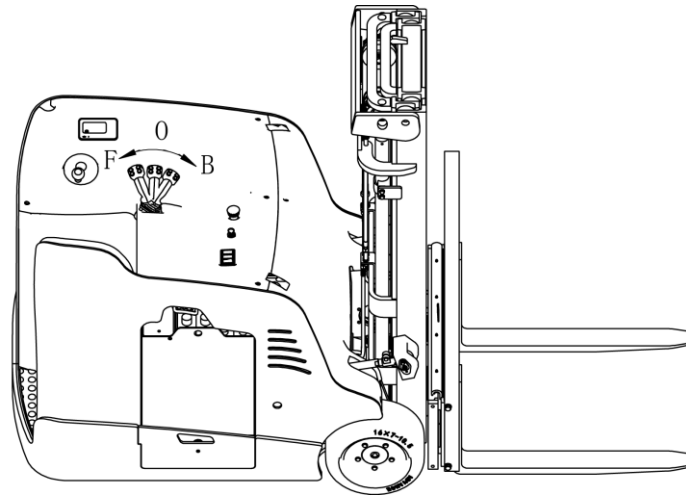

5.3 Lifting & Lowering

Step on the foot switch when driving, lower the fork to the ground completely, hold the handle lever (must hold down the safety switch) and move to the B direction until it reaches your desired lifting height.

If the fork is on the shelf, first carefully move the truck with the pallet rack or separate the truck from the shelf. Hold the handle lever (must hold the safety switch) carefully to the F direction to lower the fork away from the pallet rack, and then carefully drive the truck away from the cargo.



5.4 Fork shift left & right

Step on the foot switch, press the button(3) on the handle joystick, and the fork moves to the left.

Step on the foot switch, press the button(4) on the handle joystick, and the fork moves to the right.

5.5 Fork tilt forward & backward

Step on the foot switch, press the button(1) on the handle joystick, and the fork tilt forward . Step on the foot switch, press the button(2) on the handle joystick, and the fork tilt backward

5.6 Steering

The steering of the body can be achieved by rotating the steering wheel:

When the whole vehicle is driving forward, rotate the steering wheel in the S direction, and the whole vehicle rotation direction is S; if the steering wheel is rotated in the N direction, the whole vehicle rotation direction is N.

When the whole vehicle is traveling backwards, turn the steering wheel in the S direction, and the whole vehicle will rotate in the N direction; if the steering wheel is rotated in the N direction, the whole vehicle will rotate in the S direction.

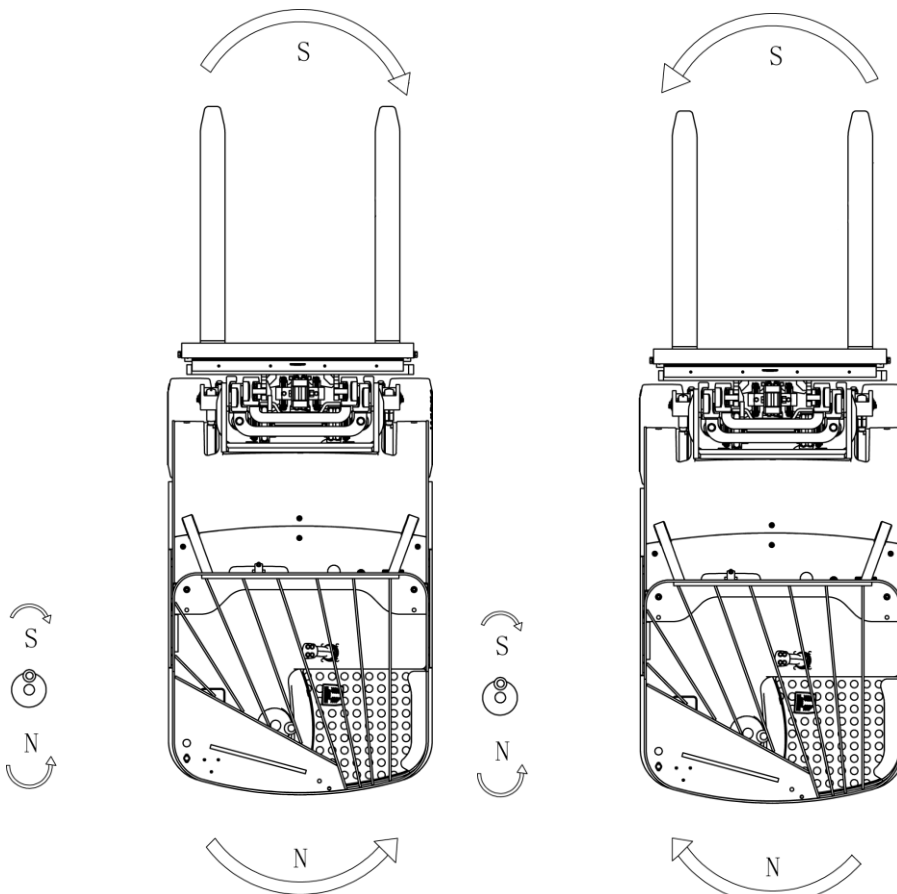

5.7 Emergency situations

During operation, if the forklift has an abnormal failure, the power supply needs to be cut off quickly, please press the red emergency stop switch.

5.8 The use of Horn and reversing Horn

For the safety of driving, the truck equipped with Horn .To remind others when driving, Press the horn button on the joystick and the horn will ring to warn pedestrians.

5.9 Monitor

Curtis instruments are used to realize auxiliary control functions and provide a display interface for the driver's truck operating conditions. It is composed of control circuit, accumulated time counter (liquid crystal display), battery fuel gauge, fault code display and other display circuits. According to the current demand of electric trucks, this instrument has a brand new design in the control circuit and display form, which can provide the driver with intuitive truck status information, compact structure, beautiful appearance, high degree of automation, and reliable quality.

Curtis instruments provide operators with some simple information about the operating conditions of the vehicle mechanism. As shown as below

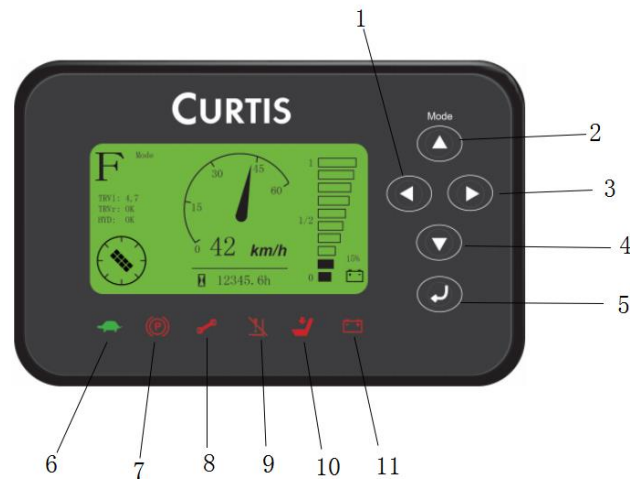

Parameter adjustment key (turn left)

1. Speed mode switch key/parameter adjustment key (upward)

3.Parameter adjustment key (turn right)

4. Parameter adjustment key (turn down)

- 5.Parameter adjustment key (Enter)
- 6.Turtle speed indicator 7.Parking indicator light
- 8. Fault indicator 9. Lifting lock indicator
- 10.foot switch indicator light 11.Battery warning light

5.10Operation

(1) How to move heavy objects on a cargo pile

Slowly drive the forklift to the object to be moved, make the fork parallel to the ground, lift the fork to a height where it can be inserted into the cargo, insert the fork and move it forward slowly, when the fork is fully inserted into the cargo Stop the car and manipulate the lifting handle to lift the heavy object to a certain height, tilt the mast backwards, and slowly reverse the vehicle. Do not touch the adjacent goods. When the heavy object completely leaves the pile of goods, lower the goods to the correct position. Running position, and then for traveling and transport.

(2) Put heavy objects on the cargo pile

Place the heavy object in a low position, tilt the mast backward, and slow down when driving toward the stack of goods. When it is determined that the forklift is in a straight line with the stacked goods, the joystick lever slowly adjusts the inclination of the mast to the vertical state to lift the weight. The object slightly exceeds the height of the stack, and then the forklift is slowly driven forward to stop above the stack. Slowly pull the joystick lever. Once the heavy objects being transported and stacked are dragged, lower the fork to the hollow position. When pulling the fork out of the heavy objects, first confirm that the back position is unobstructed before going backwards. After the forks are completely removed from the heavy objects, lower the forks and tilt the mast backwards before performing another round of handling operation.

6. Electrical Schematic diagram

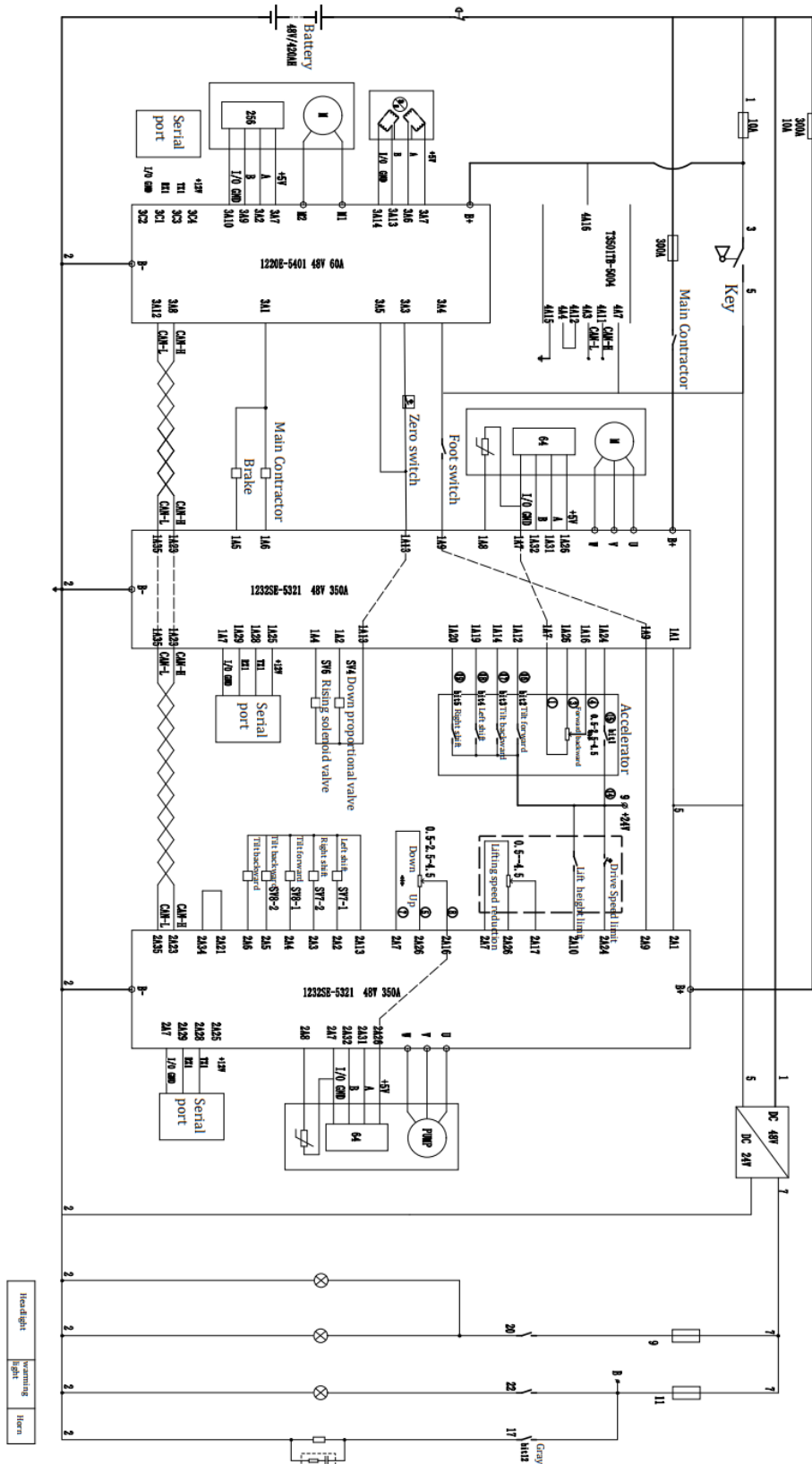

7. Hydraulic Schematic diagram

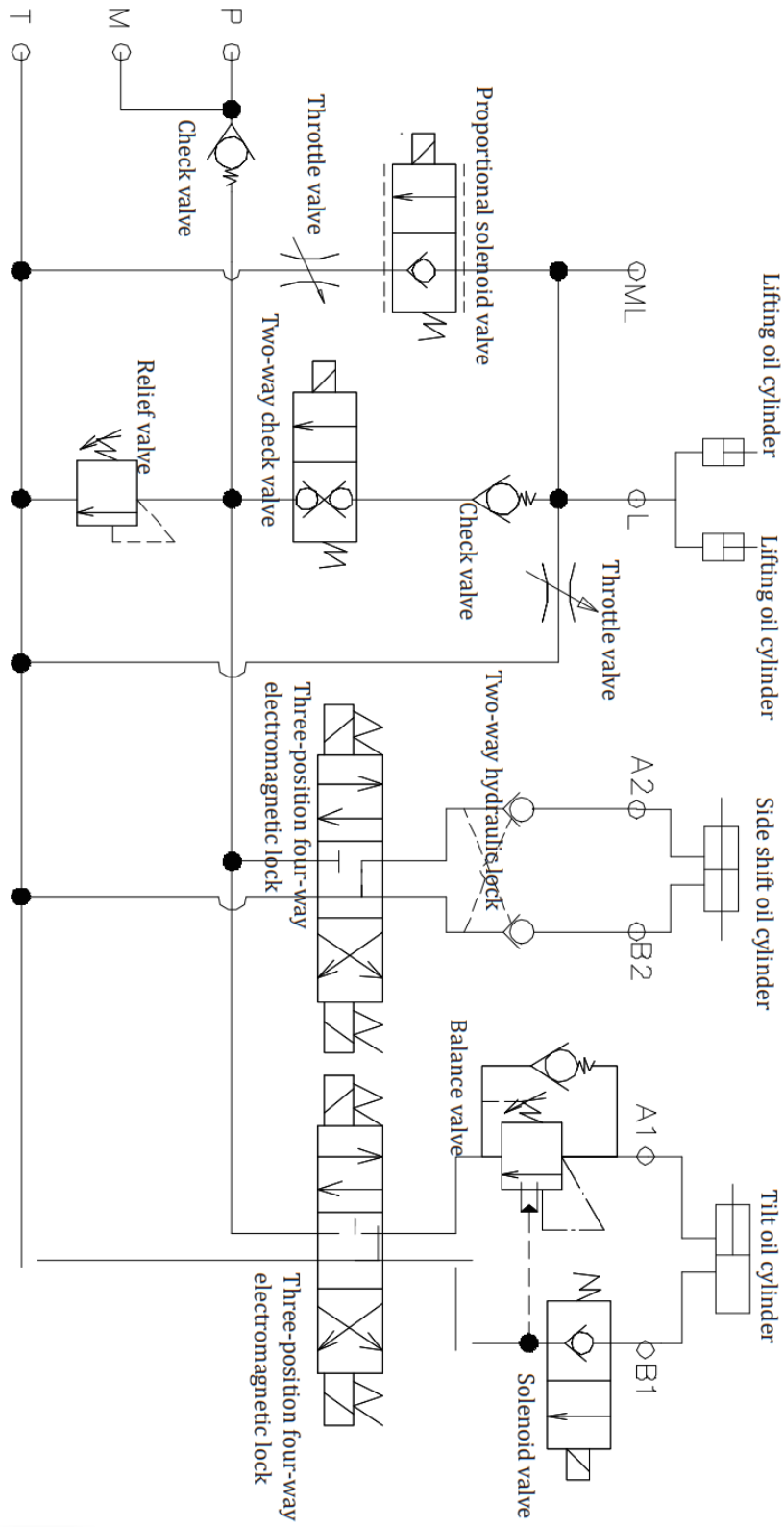

8.Maintenance and care instructions

The spare parts of the truck ,especially the safety devices are not allowed to change without permission. The driving speed of the truck must never be changed. All parts supplied by the original manufacturer are subject to strict quality inspection. To ensure the safety and reliability of the vehicle, please use the original parts. Replacement parts, including all oils, must be collected and processed in accordance with local environmental and health laws and regulations.

8.1 Repair and Maintenance

Maintenance technician: The maintenance and service should only be performed by special personnel trained by the manufacturer. After the technician sent by after-sales department of the manufacturer completed maintenance and servicing work, they should sign on the service log.

Lifting of the Truck: When a truck needs to be lifted for maintenance, the lifting device must be safe and secure and strictly attached to the lifting point. When the truck is lifted, appropriate measures must be taken to prevent the truck from slipping or tipping over (wedges, blocks can be used).

Cleaning Operation: Flammable liquid cannot be used for cleaning the stacker. Before cleaning, take safety precautions to prevent electric sparks (e.g. sparks caused by short circuit). When operating the accumulator, connectors on it must be disconnected. Use soft air suction or compressed air, non-conductive and anti-static brushes to clean electric and electronic components.

Operation of Electric System: Operation on the electric system should only be performed by specially trained personnel. Before performing any operation on the electric system, precautions must be made to prevent electric shock. When operating the accumulator, connectors on it must be disconnected.

Welding operations: To prevent damage to electrical or electronic components, these electrical components must be removed from the vehicle before any welding operations are taken.

Installation: When repairing or replacing hydraulic components, electric and electronic components, make sure to install them back to their original positions.

Wheels: Quality of the wheels has significant effect on stability and driving performance of the truck. Modification on wheels can be performed only with

the approval from the manufacturer. When replacing wheels, ensure that the truck is levelled as delivery state (wheels must be replaced in pairs, i.e. replace right wheel together with left one).

Lifting chain and rollers: Chain and rollers will be worn quickly without good lubrication. Perform periodic lubrication according to following maintenance table. Shorten the lubrication period under adverse operation conditions (such as in dusty and hot environment).

Hydraulic oil pipe: The oil pipe must be changed every 6 years. When change the hydraulic assembled parts, the oil pipe should be also changed.

8.2 Routine Maintenance

8.2.1 check the electrolyte level of the battery. The liquid level will rise when charging.

8.2.2 check the condition of each pole, cable and protective cover of the accumulator.

8.2.3 check whether the battery box is secure.

8.2.4 check whether the vehicle is oiled.

8.2.5 check the situation of lifting chain, roller, fork, oil pipe and horn.

8.2.6 check the braking condition.

8.2.7 check the wear condition of driving wheel, load wheel and so on.

8.3 Professional Maintenance Manual

It is very important for safe operation of the truck to perform overall professional maintenance. Failure in performing maintenance according to specified interval may cause malfunction of the truck, and potential risk to human and equipment.

Maintenance periods listed in this manual apply to single shift a day under normal operation conditions. If using in dusty environment, the ambient temperature varies remarkably or in multi-shift situation, the maintenance period has to be shortened.

Maintain the truck according to following maintenance list. Maintenance periods are as follows:

W = Every 50 work hours, but at least once a week.

A= Every 250 work hours, but at least once every three months

B = Every 500 work hours, but at least once every six months

C = Every 2000 work hours, but at least once every 12 months

Additional operations should be performed in trial run period:

(In initial 50 – 100 working hours or after two months)

- Check the nuts on the wheels and tighten them if necessary.
- Check the hydraulic components for leakage and tighten them if necessary.
- Replace the hydraulic filter.

Maintain list			Time interval(Month)●			
			W	A	B	C
Brake	1.1	Check the air gap of the electromagnetic brake			●	
Electrical system	2.1	Check the operation switch to show the function of	●			
	2.2	Check alarm system and safety device		●		
	2.3	Check the cable for damage and the terminal is			●	
	2.4	Check the function of the micro switch setting	●			
	2.5	Check controller and EPS controller			●	
	2.6	Cable and motor fixing			●	
Power supply	3.1	By observing the battery		●		
	3.2	Visual inspection of battery charging plug			●	
	3.3	Check if the connection of the battery cable is tight, and if necessary, apply the electrode with grease.			●	
Driving system	4.1	Check the gearbox for abnormal noise			●	
	4.2	Check the running mechanism and grease, check the reset function of the operating handle		●		
	4.3	Check the drive wheel and bearing wheels for wear and damage			●	
	4.4	Check wheel bearings and fixing conditions			●	
Whole frame	5.1	Check if the frame is damaged			●	
	5.2	Check if the sign is complete			●	
	5.3	Check the fixing of the mast			●	
Hydraulic movement	6.1	Check the function of the hydraulic system		●		
	6.2	Check hoses, pipes and connections for tightness, sealing and damage		●		
	6.3	Check the cylinder and piston for damage, sealing			●	
	6.4	Check the load chain settings and re-tension if			●	
	6.5	Visually inspect the mast rollers and check the wear on the roller faces			●	
	6.6	Check the forks and load handlers for wear and loss			●	
	6.7	Check the tank for oil level			●	
	6.8	Update hydraulic oil				●

8.4 battery maintenance, charging and maintenance.

Any operation of the battery must be guaranteed to stop the vehicle and put it in a safe position.

8.4.1 maintenance personnel.

Battery charging, maintenance and replacement must be operated by qualified professionals. You must carefully read the manual, supply preparation and charging requirements before preparing for the operation.

8.4.2 Fire protection measures.

Smoking and open fire are strictly prohibited when operating the battery. Storage battery and charge must be kept away from combustible materials, at least 6.56ft above the distance, the place of storage battery must be well ventilated and equipped with fire-fighting facilities.

8.4.3 Maintenance of the Accumulator

- 1) Keep the nuts on every battery cell dry and clean. Tighten every terminal and cable end and brush them with grease to prevent corrosion. Naked cable ends and terminal posts should be covered with a skid-proof insulating cover.
- 2) Every two cells should be well-connected. Check the nuts on each pole, if loose, tighten the nuts.
- 3) Keep the surfaces of accumulator clean and dry. After the completion of recharging, clean spilled acid with cotton yarns or brush. And clean with wet towel if necessary.
- 4) Over recharging and over discharging should be avoided, and fast charging and insufficient recharging are also not allowed. Otherwise life span of the accumulator may be affected.
- 5) Do not put conductive objects including metal tools on the accumulator, or short circuit or even explosion may be caused.
- 6) Never spill any hazardous liquid or solid material on surfaces of the accumulator. When using a densimeter or a thermometer, make sure the surface is clean and clear.
- 7) Recharge the discharged accumulator in time. Delayed recharging may damage the accumulator. Do not delay recharging more than 24 hours. Recharging of the accumulator may not work outdoors in cold weather. In this case, move it indoors to perform recharging.

8) If the accumulator will not be in use for a long time, it should be recharged and discharged once every month and it should be fully recharged every time.

9) During recharging or using, the liquid level of electrolyte lowers because of water evaporation, so pure water should be added.

10) If individual cell fails, identify the cause and repair the cell immediately. Replace the cell when it cannot be repaired.

11) The site for recharging should be well ventilated. It is prohibited to smoke or use open fire, avoiding the risk of hydrogen explosion.

12) The electrolyte in accumulator is toxic and corrosive. For this reason, always wear working suit and protection glasses to protect your body from contacting the electrolyte in accumulator.

13) If your clothes, skin or eyes are spilled with acid liquid in accumulator, flush with large amount of clean water. For skin and eyes, flush with large amount of clean water and also seek doctor's treatment immediately. Acid spillage must be neutralized and treated immediately.

14) The weight and dimensions of the accumulator have remarkable effect on stability of the truck. Therefore, do not modify the type of accumulator without approval from the manufacturer.

15) Never discharge in large current, for example, performs travelling and lifting simultaneously.

8.4.4 Disposal of used batteries.

Scrap battery must be carried out in accordance with the relevant laws and regulations in region recycling, storage provisions stipulated by the environmental protection area or waste treatment area, and the work must be conducted by qualified professional company.

8.4.5 Precautions for battery use

The life of a battery is generally about 2 to 3 years. If used and maintained properly, it can be used for more than 4 years. If used and maintained improperly, it will be damaged early within a few months.

The battery should be checked regularly for the height of the electrolyte during use, and the storage status of the battery should be checked and supplemented in time. Battery maintenance is relatively simple but requires patience and meticulousness. Do a excellent job in electrolyte supplement and density control, battery and lead pole cleaning, etc., which can effectively extend the service life of the battery.

Check whether there is water in the battery box, and if the water is found, absorb it immediately.

In addition, batteries should not be stored with electrolyte. If you want to store used and fully charged batteries for a short period of time, you must charge them every month during the storage period to compensate for battery self-discharge and prevent vulcanization or elimination of battery plates. The battery plate is slightly vulcanized, and the condition of the battery should be checked frequently.

If the battery cannot be fully charged and fully discharged during use, it must be fully discharged and fully charged once a month. This can maintain the capacity of the battery and avoid sulfation of the plates.

Keep the outside of the battery clean

Check the fixing condition of the battery and the lead-out wire clamp, there should be no looseness.

Check that the battery shell should not be cracked or damaged, and the pole and lead clamp should not be burnt.

Wipe the external dust of the battery with a towel. If there is electrolyte overflow on the surface, wipe the dirt with a towel or rinse with hot water, and then wipe dry with a towel. Clean the dirt and oxide on the pole pile head, wipe the outside of the connecting wire and the lead clamp, and remove the dirt. Unblock the vent hole of the filler cap and clean it. During installation, apply a thin layer of industrial petroleum jelly on the poles and lead clamps.

Inspection of battery liquid level:

A glass tube with an inner diameter of 0.24-0.32Inch and a length of about 150mm can be inserted vertically into the filling port until it reaches the edge of the electrode plate, and then press the upper mouth of the tube with your thumb, and use the index finger, middle finger and ring finger to clamp out the glass tube, The height of the electrolyte in the glass tube is the height of the electrolyte plane in the battery above the electrode plate, which should be 15-25mm. Finally, replay the electrolyte into the original single cell battery.

Replenish electrolyte

If the electrolyte level is too low, you should add distilled water in time. Do not add tap water, river water or well water to avoid self-discharge failure caused by mixing impurities; do not add electrolyte, otherwise it will increase

the electrolyte concentration and shorten the battery Service life. Note that the electrolyte level should not be too high to prevent the electrolyte from overflowing during charging and discharging, causing short circuit failure. After adjusting the liquid level, the battery should be charged for more than 0.5 hours so that the added distilled water can mix with the original electrolyte evenly. Otherwise, it is easy to freeze the battery in winter.

Check the density of electrolyte

The density of the electrolyte varies with the degree of battery charge and discharge. The decrease in electrolyte density is a manifestation of the degree of battery discharge. By measuring the electrolyte density in each cell, the degree of discharge of the battery can be understood.

(1) Measurement method: Unscrew the liquid filling port cover of each cell of the battery and suck out the electrolyte from the liquid filling port with a density meter until the float of the density meter floats. When observing the readings, the density meter should be raised to a position flush with the line of sight of the eyes, and the float should be in the center of the glass tube without touching the tube wall, so as not to affect the accuracy of the readings

If the temperature is lower than 25°C or higher than 25°C, use a thermometer to measure the actual temperature of the electrolyte to correct the density value of the electrolyte

(2) Correction of electrolyte density: the density of electrolyte at different temperatures has a certain error, and the measured electrolyte density value needs to be corrected. The electrolyte density is based on 25°C. Therefore, during measurement, if the electrolyte temperature is higher or lower than 25°C, 0.0007 should be added to the actually measured density value for every 1°C higher; on the contrary, if the electrolyte temperature is lower than 25°C, 0.0007 should be subtracted for every lower 1°C; If the temperature difference is large,

It can be corrected as follows:

The density of electrolyte standard temperature (25°C) is converted by the following formula:

$$D_{25} = D_t + 0.0007(t-25)$$

D_{25} ——The density of electrolyte at 25°C

D_t ——The measured density of electrolyte at t °C

t-electrolyte temperature when measuring density

8.4.6 Storage, transportation, and installation of batteries

The truck must be stopped on a level ground. To avoid short circuits, the exposed terminals and terminals of the battery must be covered with insulating covers. When the battery is pulled out, the connectors and cables of the removed battery must be properly placed so that they cannot obstruct the access of the battery.

When using lifting equipment to load and unload batteries, ensure that the lifting equipment has sufficient load capacity (the weight of the battery is indicated on the battery and truck nameplate). The lifting device must be pulled in the vertical direction to avoid damage to the battery box. The hook of the lifting device must be safe and reliable, and the hook must not fall on a single battery in the battery pack.

- Press the emergency stop switch and turn the power key switch to the OFF position to make it in the cut-off position.
- Disassemble the connector of the battery cable.
- Connect the lifting device to the lifting eye.
- Lift out the accumulator from directly above and remove it with handling equipment.

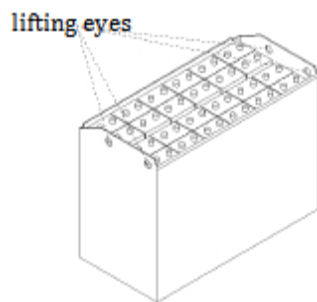

The installation process is reversed. Please notice that the location of the battery should be correct, and the wiring should be reliable. After the battery is reinstalled, check all cable connections and connector connections for obvious damage.

8.4.7 Charging

(1) Initial charging (Our company's products generally have been charged before the initial charging, users do not need to perform this operation)

The quality of the initial charge has a greater impact on the battery, and it must be operated by personnel with certain experience.

The unused battery should be initially charged before use.

The surface of the battery should be wiped clean before initial charging and checked for damage.

Open the flip cover on the filling port cover to ensure that the ventilation holes are unblocked.

Under the condition that the charger can work normally, pour a sulfuric acid electrolyte with a density of 1.26 ± 0.005 (25°C) and a temperature lower than 30°C into the battery, and the liquid level must be 0.59 to 0.98 inch higher than the protective plate.

Leave the battery for 3 to 4 hours, not more than 8 hours. The initial charging can be performed only when the liquid temperature drops below 35°C . If the electrolyte level drops after standing, Then Electrolyte should be added

Sulfuric acid electrolyte is prepared from battery sulfuric acid and distilled water (do not substitute industrial sulfuric acid or tap water) that meets the national standard GB4554-84.

When preparing, it is only allowed to slowly pour concentrated sulfuric acid into distilled water in a trickle, and continuously stir with acid-resistant glass rods or lead-clad wooden rods. Never inject distilled water into sulfuric acid, otherwise it will cause the solution to boil and splash and cause burns. accident.

The connection line between the charger and the battery requires correct polarity, that is, the positive pole is connected to the positive pole and the negative pole is connected to the negative pole, and the connection is required to be reliable.

0.5I5A (60A for D-600 battery) is used for the first stage of initial charging, and when the cell voltage reaches 2.4V

Enter the second stage of initial charging.

0.25I5A is used for the second stage of initial charge (30A for D-600 battery);

During the charging process, the temperature of the electrolyte should not exceed 45°C. When it is close to 45°C, the charging current should be halved, or the charging should be suspended; etc.

Resume charging after the electrolyte temperature drops below 35°C. But need to extend the charging time appropriately.

Basis for full charge: charge to a voltage of 2.6V in the second stage of the initial charge, and the voltage change is not more than 0.005V; the density of the electrolyte reaches 1.28 ± 0.005 (25°C), there is no obvious change within 2 hours and there are fine bubbles intense. When it happens, the battery is considered to be fully charged. The charging power is 4 to 5 times the rated capacity, and the charging time is about 70 hours.

In order to accurately control the sulfuric acid content in the electrolyte, the density of the electrolyte of each battery should be checked at the end of charging; if there is any discrepancy, use distilled water or sulfuric acid with a density of 1.40 to adjust, and it should be within 2 hours of the charging state. Adjust the density and liquid level of the electrolyte to the specified value;

After the initial charge, wipe the surface of the battery clean and cover the filling port before putting it into use.

(2) Normal charging

Undercharged batteries cannot be used. The battery should pay close attention to the degree of discharge during use. If the discharge exceeds the regulations, it should be charged. It is strictly forbidden to over-discharge—that is, when the voltage drops to 1.7V/pc, and when the electrolyte density drops to 1.17, the discharge should be stopped and charged in time, and should not be left for a long time. During the charging process, the battery must not be stopped halfway without reason.

When performing ordinary charging, first open the flip cover on the filling port cover to check whether the electrolyte is at the specified height, otherwise, use distilled water to adjust the liquid level of the battery to the specified height.

Connect the output of the charger to the battery as required. Connect the positive pole to the positive pole and the negative pole to the negative pole.

The charger matched with the battery can automatically adjust the charging current according to the state of charge of the battery until the battery is fully charged. (For observation of the charging status, please refer to the manual of the charger)

In order to understand the condition of the battery in time, it is recommended to establish a charge and discharge record for each battery, so as to provide a useful basis for judging whether the battery fails in the future. During the charging process, measure and record the current, total voltage, voltage of each cell (numbering), electrolyte density and temperature (0~100°C mercury thermometer can be used) every 1-2 hours. .

When a large number of uniform and dense bubbles appear in the electrolyte, the cell voltage is stable at 2.5-2.7V, and the electrolyte density and terminal voltage do not continue to rise within 2-3 hours, it means that the battery is fully charged. If there is weak or no gas in individual units, the cause should be found out, dealt with, and recorded in the work log.

The electrolyte temperature must not exceed 45°C during charging. During the charging process, the temperature of the electrolyte should not exceed 45°C. When it approaches 45°C, the charging should be suspended; wait until the electrolyte temperature drops below 35°C before continuing to charge.

When the battery is finished charging, check and adjust the electrolyte density of the battery. If the electrolyte density does not meet the requirements, you can first draw out some of the electrolyte in the original cell. If the original density is too low, you can add a concentrated electrolyte with a density of 1.40 to adjust; if the original density is too high, you can add distilled water for dilution. After adjustment, the difference in density of each single cell electrolyte should not exceed 0.01, and the height of the liquid level should meet the requirements. After density adjustment, continue charging with a small current for 0.5 hours to make the electrolyte mixed evenly, then recheck the electrolyte density and adjust if necessary. Finally, wipe the battery clean and load it into the car.

(3) Equalization charging

Under normal circumstances, although all batteries in the battery pack are operating under the same conditions, it may be unbalanced for the entire battery pack for some reason. In this case, the equalization charging method should be used to eliminate the battery To achieve the balance of the entire battery pack.

The equalizing charging method is simple and can be operated according to the charger manual.

Normally used batteries shall be equalized and charged every 2 to 3 months. Batteries that have not been used for a long time should be balanced and charged before use.

9.Safety Caution

9.1 General rule

9.1.1 The operator must have a forklift operation qualification which proved by the relevant departments of the training before driving truck.◦

9.1.2 The operator must read the instructions before use all of the content, after fully understand operation method can drive Truck.

9.1.3 truck must not carry passengers.◦

9.1.4 Operators should pay special attention to when homework operating environment, including other people nearby and fixed object.

9.1.5 Without the manufacturer's approval, shall not modify, add or remove tractor parts, lest affect performance of tractor.

9.2 Storage and transportation

9.2.1 Use container or car to transport the truck should pay attention to at the time of shipment:

① The front and rear wheels are fixed with wedges, and the emergency stop switch is pressed to prevent sliding during transportation.

② Using the lasso, not placed in the weak structure of the truck.

③ When transporting in a truck take care to keep the center of gravity of the truck in the middle of the forks.

9.2.2 When Truck doesn't work, should be parked in a dry ventilated cleaning warehouse, prevent weathered.

And please note:

① Turn off the Electrical lock and make the safety switch off, unplug the power plug

② Pad the front and rear wheels with pads

③ Such as discontinued for a long time, battery should be added once every 15-day electricity.

9.3 Check before using

9.3.1 New car if there is any damage in transportation, please don't be put into use, and promptly get in touch with the supplier, do proper processing.

9.3.2 New cars in the factory run parts has been filling lubricating oil.

9.3.3 Truck equipped with battery. The battery is charged before leaving factory. If leaving the factory for a long time, may the battery be low. Before use should pay attention to electricity meter shows that when the electricity meter display to the last two warning, must charge at once. Every day before using, or before charging, should open the battery blocks, check the liquid level height, such as liquid level is too low to add distilled water in charge. Detail as (Battery charging and maintenance

9.4 Safety operation regulation

9.4.1 Requirement for operator: The Truck must be operated by a trained operator, He can perform and operation demonstration on the user to move and manipulate the cargo, and can clearly guide the user how to operate the forklift.

9.4.2 Operator's rights, obligations and responsibilities: Has been trained by the operation of the vehicle, the driver must be clear of his rights and obligations; and he is familiar with the contents of the relevant operating instructions. If the vehicle is pedestrian type, the driver must also wear safety boots.

9.4.3 Prohibit unauthorized person to operate: The operator is responsible for the vehicle, he needs to prohibit unauthorized person to operate. Transport or lift person is also forbidden.

9.4.4 Malfunctions and defects: If the vehicle has any malfunctions or defects, need to inform administrator, If the vehicle cannot be safely operated (e.g.: wheel wear or brake failure), then it must stop using until it is fully repaired.

9.4.5 Safe operation and environmental protection: inspection and maintenance must be performed in accordance with the time intervals on the maintenance list.

Parts of the vehicle cannot be changed without any permission, especially safety devices. The operating speed of the truck is not allowed to change.

All original spare parts have been verified by quality assurance department. To ensure the safety and reliability of the operation of the truck must use only the manufacturer's spare parts. The old parts, such as oils and fuels must be handled in accordance with the relevant environmental protection rules.

9.4.6 Hazardous area: Hazardous area usually refers to the following range: vehicle or its load lifting devices (e.g. fork or accessories) is dangerous for personnel when running or lifting movements, or the ongoing regional transport loads. Typically, this range extends to the load or truck accessories landing area.

Unauthorized personnel must be asked to leave the dangerous zone. As long as the situation might cause some kind of damage, the driver must give a warning, if the driver asked the person to leave but did not leave the hazardous zone, the driver must immediately stop the vehicle.

9.4.7 High-risk environment: Working in high-risk environment, operator must have a special design to be protected.

The vehicle was not specially designed for the high-risk environment.

9.4.8 Safety devices and warning signs: Safety devices, warning signs and warning notes described in the previous operating instructions must be taken seriously enough.

9.4.9 Driving in public places: the vehicle is forbidden to drive in public places except in specified special areas.

9.4.10 Distance between truck: keep an appropriate distance, avoid the front vehicle suddenly stop.

9.4.11 headroom: When the headroom is below the cargo or mast, it is forbidden to use the vehicle.

9.4.12 Using in the elevator and loading platform maneuvering: if there is sufficient loading capacity, won't affect the operation of the vehicle, and being agreed by the operator of the vehicle, then the elevator and loading platform can be used for vehicle transport. Before entering the elevator or loading station, operator must personally identify. The goods must be placed in front and occupy an appropriate place, to avoid touching the wall of the elevator when the vehicle enters the elevator. When personnel and vehicles take the elevator together, person can enter only after the vehicle has safely entered, and person must leave before the vehicle.

9.4.13 Driving aisle and working area: The vehicle must be operated on the specified aisle, all non-related person must leave the work area, and cargo should be stacked in designated places.

9.4.14 Operation Management: Driving speed must be adapted to local conditions. When through the corners, narrow passage, swing doors and closed place, speed must be slowed down. Drivers must be able to visually an adequate braking distance between vehicle and the front vehicle, and he must remain in control of his vehicle. Sudden stop (unless urgent needs), rapid U-turn, chased each other in the Aisle is not allowed. Do not pry out of the body to operate the vehicle.

9.4.15 Visibility: The driver must look attentively at the direction of driving, to ensure the front situation is clearly visible. When the vehicle is backing off, if the carriage of goods block the line of sight, a second person walk in front of the vehicle to give appropriate guidance and warnings is necessary.

9.4.16 Pass through the ramp: Only a known ramp which should be clean, non-slip, and with the vehicle technical availability was allowed to go through.

The goods on the forks must face uphill. It is forbidden to turn back, move diagonally or park on the ramp. The operator must slow down when going through the ramp and prepare to brake at any time.

9.4.17 Load capability on ground: when the vehicle is in operation, make sure the load pressure of the body weight or wheels on the ground does not exceed the load capacity of the ground .

9.4.18 Vehicle Change: Any possible changes or modifications for rated load, stability or safe operation of the vehicle, must obtain prior written approval from origin manufacturers or its successor. After vehicle manufacturer check and approve the changes, nameplates, labels and markings of Operation and Maintenance Manual must be modified as well.

10.Service Manual

1.1 Troubleshooting

Fault	Cause	Treatment
The truck cannot move	The battery connector is not connected	Check the battery connector, connected if necessary
	Electric lock switch on "OFF" position	Electric lock switch turns to "0" position
	Emergency Stop Switch not open	Open the Emergency stop switch
	Battery power runs out	Check the battery charge, If it is necessary to recharge
	The vehicle being charge	Interrupt charging process
	The fuse is damaged	Check the fuse
	The foot switch is not stepped on, and the handle safety switch is not pressed	Step on the foot switch, press and hold the handle safety switch
Goods cannot lift up/lower down	The vehicle is not operating	Handle according to the treatment method listed in Vehicles cannot move"
	Low hydraulic oil level	Check hydraulic oil
	The fuse is damaged	Check the fuse
	Overloading	Pay attention to the rated capacity
	Dirty oil blocking control valve	Check the hydraulic oil and clean the control valve, replace the hydraulic oil if necessary
	The descending solenoid valve is not open or damaged	Check the descending solenoid valve or replace
	The foot switch is not stepped on, and the handle safety switch is not pressed	Step on the foot switch, press and hold the handle safety switch
Can't stop when lifting	Lifting micro switch is damaged	Cu off the power and replace lifting micro switch
Moving in one	The Micro witch and the	Check the micro switch in control

direction	connecting cable are not well-contacted.	lever and the connecting cable.
The vehicle travels very slow	The related cable is not well-connected	Check the battery indicator light and related cable
The car suddenly started	Controller is damaged.	Change the controller
	The handle which control the forward or back is no reset.	Repair or change

If above steps still cannot solve problems, please contact after-sales service department of the manufacturer and have the problems solved by specially trained technicians.

10.2 Preparation before repair

To prevent possible accidents during maintenance and repair work, following preparations must be done:

- Park the device safely.
- Press the emergency stop switch and disconnect the connectors on accumulator.

10.3 Check the amount of hydraulic oil

- A vehicle ready for repair or maintenance。
- Open the electrical box cover。
- Check the amount of hydraulic oil in the tank。

When checking the hydraulic oil level, the fork and mast must be lowered to the lowest position.

10.4 Complete repair, the preparation before using

Use the device only after following operations have been completed.

- Clean the vehicle
- Check the brake.
- Check the emergency stop switch.。

— Check the horn.

Several electromagnetic brake tests need perform immediately after the test

11.After-sales service

If there is a fault that cannot be eliminated by professional service personnel, please contact our after-sales service personnel in timer

**This manual final interpretation retained by
manufacturers.**