



EB13E SERIES
**EB13E/EB13E-138/
EB13E-LI/EB13E-138LI/EB13E-
145LI/EB13ES-LI/EB13ES-145LI**
ELECTRIC PALLET STACKER
INSTRUCTION MANUAL

Welcome to use the pallet stacker
Hope our products can bring you greater convenience!

- Please read the instructions carefully before you use the pallet stacker.
- This manual is a general manual and we reserve the right to make technical modifications to this product. If there are any differences between the manual and the actual product, please refer to the actual product, and the instructions are for reference only.

Warning

Vehicle operators must strictly implement ISO3691 "Safety specification for motor vehicles", and untrained personnel are strictly prohibited to operate the vehicle. According to ISO3691 "Safety specification for motor vehicles", the load and lifting height of QES-ZY electric pallet stacker produced by our company are as follows: Its load capacity can be referred to the following figure. The following is the rated load of 1500Kg load curve.

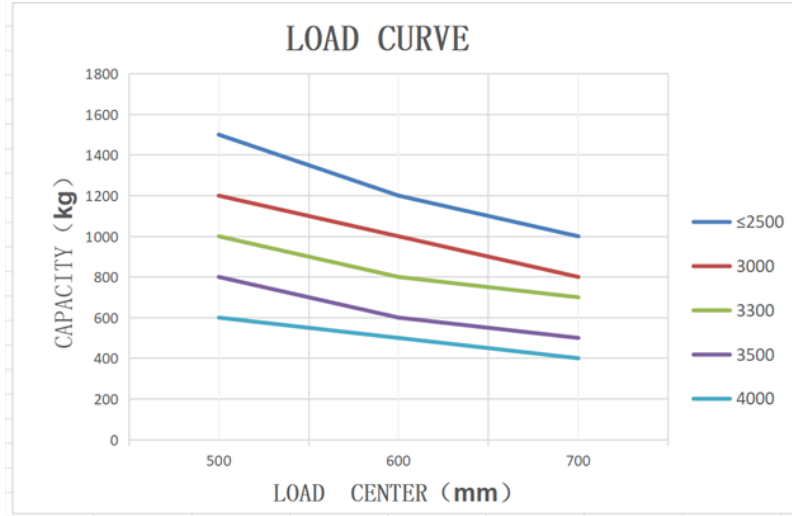

Please use strictly according to the load curve, do not overload

Attention:

When the lifting height of the fork exceeds 500mm, the car must drive in a straight line at the lowest speed. Shall not turn to drive and the continuous walking distance shall not exceed 2m.

Failure to comply with these rules can result in:
A Serious risk of injury to the driver or other person.
B Damage to vehicles and goods.

Forward

Before operating this stacker, please read this manual carefully and fully understand how to use this stacker. Improper operation may cause danger. This manual describes the use and operation of different types of pallet stackers. When servicing the stacker, make sure it matches your model. Please keep it for future use. If this manual or warning/warning label is damaged or missing, contact your local dealer for a replacement. This stacker complies with EN 3691-1 (Industrial vehicles - Safety requirements and verification, Part 1), The standards of EN 12895 (Industrial vehicles - electromagnetic compatibility), EN 12053 (Safe industrial vehicles - test methods for the measurement of noise emissions), EN 1175 (Safety of industrial vehicles - electrical performance requirements) must ensure that the vehicle is used in accordance with the above purposes. According to EN 12053, the noise level in the driver's ear is 69 dB(A). According to EN 13059 (if the vehicle has pedals), the vibration is 0,85 m/s².

Attention:

- Hazardous waste that is harmful to the environment, such as waste batteries, waste oil and electronic products. If not properly disposed of, it will have a negative impact on the biological environment or human health.
- Waste packaging should be classified into solid waste bins according to the material, and collected by the local special environmental protection bureau. In order to avoid pollution, it is forbidden to throw litter at random.
- In order to avoid oil leakage when using the product, users should prepare some absorbable materials (waste wood chips or dry rags) to absorb the leaking oil in time. In order to avoid secondary pollution of the environment, used absorbable materials should be handed over to specialized departments in accordance with local authority regulations.
- Our products continue to improve, because this manual is only for the operation/maintenance of the stacker for the purpose, so this manual can not guarantee other special circumstances. Please understand.



Note: In this manual, the symbols on the left indicate warnings and dangerous conditions that could result in death or serious injury if not followed.

Copyright

Copyright is reserved by the company mentioned in the CE standard at the end of this document.

Contents

Foreword

1. Proper use
2. Main technical parameters
3. Safety specifications
4. Instructions for use and operation
5. Steps for vehicle steering operation
6. Maintenance
7. Common faults and troubleshooting methods
8. Schematic diagram

1. Proper use

This pallet stacker is only allowed to be used in accordance with this instruction manual.

The stacker described in this manual is a self-propelled, walking pallet stacker with the function of electrically operated height control. This stacker is designed to lift, lower and transport rack loads.

Improper use can result in personal injury or machine damage. The operator/operating company shall ensure proper use and that the stacker is only operated by persons who have been trained and authorized to use the vehicle.

The stacker must be used on a solid foundation, flat, intact plane and suitable surface. The vehicle is designed for indoor use at room temperature from +5C to +40C and for light loads without crossing permanent obstacles or potholes. It is prohibited to operate on slopes. When operating, the goods must be placed approximately at the center of the load of the stacker. Lifting or carrying of persons is strictly prohibited. If carried, the cargo must be lowered to the lift point.

It is prohibited to use this vehicle on the tailgate or on the loading ramp.

The load rating is indicated on the capacity label and nameplate, and the operator must pay attention to these warning signs and safety instructions. Operating illumination must be at least 50 lux.

Changes

Any alteration that may affect the load rating, stability or safe operation of the vehicle shall be subject to the prior written approval of the vehicle's manufacturer of origin or its authorized manufacturer or its replacement. This includes the effects of changes such as increased braking, steering, visibility and movable accessories. When modification or changes have been approved by the manufacturer or its replacement, nameplate capacity, labels, identification marks, operation and maintenance manuals will be changed accordingly.

Failure to follow these instructions to cause damage to the vehicle will result in loss of warranty.

2. Main technical parameters

A. Outline drawing

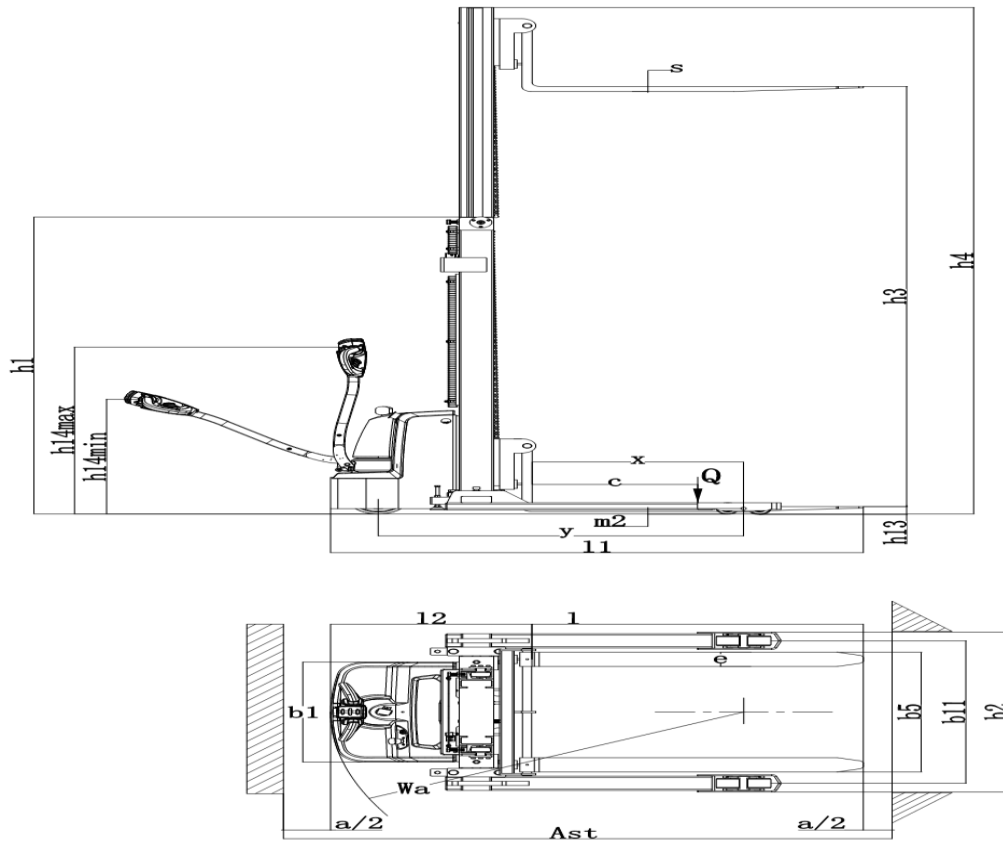

Characteristics	Reduce the height of the support frame $h1$ (in)	Freedom to ascend to greater heights $h2$ (in)	Improve ment $h3$ (in)	The extendable height of the gantry $h4$ (in)	Lifting + lowest height of the fork $h3+h13$ (in)
Two gantries	62.2	—	76.4	100.4	78.7
	72.0	—	96.1	120.1	98.4
	81.9	—	115.7	139.8	118.1
	91.7	—	135.4	159.4	137.8
Fully free two frames	—	—	—	—	—
Three-column gantry	—	—	—	—	—
Three-column free-standing structure	—	—	—	—	—

B. Main technical parameters

EB13E SERIES - EB13E/EB13E-138/EB13E-LI/EB13E-138LI/EB13E-145LI/EB13ES-145LI					
Distinguishing mark	1.2	Manufacturer's type designation			
	1.3	Power(battery,diesel,petrol gas>manual)		battery	
	1.4	Operator type		Pedestrian	
	1.5	Load capacity/Rated load	Q(lbs)	3,300	
	1.6	load centre distance	C(in)	23.6	
	1.8	Load distance,centre of drive axle to fork	x(in)	28.9	
Weight	1.9	Wheelbase	y(in)	49.9	
	2.1	Service weight	Lbs.	1,250	
	2.2	Axle loading,laden front/rear	Lbs.	\	
Tires,chassis	2.3	Axle loading,unladen front/rear	Lbs.	\	
	3.1	Tires		PU	
	3.2	Tire size,front	$\Phi \times W$ (in)	$\Phi 8.3 \times 2.8$	
	3.3	Tire size,rear	$\Phi \times W$ (in)	$\Phi 3.1 \times 2.8$	
	3.4	Additional wheels(dimensions)		$\Phi \times W$ (in)	$\Phi 3.9 \times 1.6$
	3.5	Wheels,number front/rear(x=driven wheels)			1x4
	3.6	Track,front	b10(in)	\	
Dimensions	3.7	Track,rear	b11(in)	39.4-55.1	
	4.3	Free lift height	h2(in)	\	
	4.4	Lift height	h3(in)	118-145	
	4.19	Overall length	l1(in)	72.8	
	4.20	Length to face of forks	l2(in)	27.5	
	4.21	Overall width	b1(in)	27.6/(44.2-59.9)	
	4.22	Fork dimensions	s/e/l(in)	1.4x3.9x45.3	
	4.25	Distance between fork-arms	b5(in)	8.3~33.5	
	4.32	Ground clearance,centre of wheelbase	m2(in)	1.6	
	4.33	Aisle width for pallets 1000X1200 crossways	Ast(in)	90.2	
	4.34	Aisle width for pallets 800X1200 lengthways	Ast(in)	88.5	
Performance	4.35	Turning radius	Wa(in)	56.5	
	5.1	Travel speed,laden/unladen	Mph	2.5/2.7	
	5.2	Lift speed,laden/unladen	ft /s	0.13/0.33	
	5.3	Lowering speed,laden/unladen	ft /s	0.39/0.39	
	5.8	Max.gradeability, laden/unladen	%	4/6	
	5.10	Service brake		Electromagnetic	
Electric-engine	6.1	Drive motor rating S2 60min	Hp	1.0	
	6.2	Lift motor rating at S3 10%	Hp	3.0	
	6.6	Energy consumption acc. to VDI cycle	kWh/h	\	
Additional data	8.1	Type of drive control		DC speed control	
	8.4	Sound level at driver's ear acc. to EN 12053	dB(A)	70	

3. Safety specifications



Warning

Before using this stacker, pay attention to the following matters:

- (1) The stackers are only used indoors where the ground is flat and hard. Do not use in a corrosive environment such as flammable and explosive or acid and alkali.
- (2) Only trained and recognized drivers can operate the vehicle.
- (3) Read this manual carefully and master the vehicle performance before operating the vehicle. Check the vehicle carefully before each use. It is forbidden to use a faulty vehicle and repair it yourself without training.
- (4) Overload is strictly prohibited.
- (5) When handling, the center of gravity of the goods must be within two cargo forks. Do not handle loose goods.
- (6) When the fork enters and exits the pallet, the vehicle should drive slowly.
- (7) It is strictly prohibited to press the lifting or lowering button when the car is driving. It is strictly prohibited to quickly and frequently switch the lifting or lowering button because rapid and frequent lifting or lowering will cause damage to the vehicle and goods!
- (8) Do not allow heavy objects to be quickly loaded on the fork!
- (9) Do not place the goods on the stacker for a long time!
- (10) It is strictly prohibited to make a sharp turn on the narrow passage. It should slow down and turn slowly to ensure the safety of personnel and goods.
- (11) When the stacker is not in use, the fork should be lowered to the lowest position.
- (12) This truck is used on flat ground or flat working platform and Long-term parking on slopes is strictly prohibited.

3.1 Safety Operation Specifications

(1) Driver training:

Attention!

With the same technical parameters of each vehicle braking, acceleration and other characteristics may be different. Get familiar with the operation before driving the vehicle.

(2) Wear when driving:

Attention!

Please wear safety shoes and overalls. For safety, please do not wear loose clothes, so as not to be caught and dangerous.

(3) Rules must be followed:

Attention!

Do not drive when you are tired, distracted, under the influence of narcotics or alcohol.

(4) Safety of workplace:

Attention!

Vehicles are only used indoors with flat and hard ground and are strictly prohibited from being used in corrosive environments such as flammable and explosive or sulfuric acid.

A Maintain good road conditions and no obstacles.

B The workplace needs plenty of light.

C Fire-fighting equipment must be available in the place where the vehicle is used and charged and the fire extinguisher must meet the requirements for extinguishing solid combustibles and electrical fires.

D The value of the vehicle noise in the manual refers to the value measured by the new vehicle under the condition of a level, smooth and hard road. If your road condition is not good or the wheel is damaged, the noise of the vehicle may become louder.

(5) Ensure the integrity of the car:



Warning: Don't modify your stacker

A When operating, inspecting and servicing your vehicle, follow the safety rules and the rules of your workplace.

B No changes may be made to the vehicle without authorization. Modifying the vehicle may affect the safe operation of the vehicle. It is prohibited to make changes to vehicles that may affect the vehicle's carrying capacity, stability and safety without the written permission of the original vehicle manufacturer, authorized agent or consignor. When changes are approved by the manufacturer or contractor, appropriate changes should also be made to the load pallets, labels, labels and operation and maintenance manuals. Users can make changes to electric industrial vehicles only if the vehicle manufacturer is no longer operating and there is no contractor. However, the user must:

a) Arrange for vehicle changes to be designed and tested and the process carried out by engineering experts in industrial vehicles and safety.

b) Maintain permanent records of the design, testing and execution of vehicle changes.

c) Approve and make appropriate changes to load pallets, labels, labels and instruction manuals.

d) Attach a permanently visible label to the vehicle to indicate how the vehicle was changed, the date of the change and the name and address of the organization that completed the work.

(6) Establish safe operating procedures

Before using the vehicle, please Establish safe operating procedures according to the actual situation. Fully consider safety when developing work procedures.

(7) In the case of unsafe operation is strictly prohibited to operate the vehicle:

A It is strictly prohibited to use the vehicle in the place where the ground is uneven, the road is not smooth and other unsafe factors exist, and it is strictly prohibited to lift goods on the ramp.

B Never use a broken down vehicle.

C Make sure to check the vehicle every day and repair or replace it if any abnormal condition is found.

(8) It is prohibited to use the vehicle with overload:



Warning: Do not overload the use of the vehicle, overload use will damage the vehicle, or cause injury to personnel

(9) Use appropriate pallets:

The size of the pallet used should be appropriate, not too wide or too large.

(10) Electrical system inspection:

Attention!

Turn off the key switch and the emergency isolation switch when checking the electrical system.

3.2 Safe driving regulations

(1) Check the safety situation around the vehicle

Attention!

- Make sure no one is around your vehicle before you drive it.
- When carrying a large cargo, the line of sight is blocked by the cargo, please back up or be guided by others.
- When backing up, make sure no one is around the vehicle.
- Someone should guide you when you are driving in narrow passages.
- Drivers should stop at intersections or other places where the line of sight is blocked and make sure no one is left or right before driving.
- Pay attention when driving a vehicle.



Be careful

Unlike ordinary vehicles, the driving mechanism of the vehicle is installed in the front of the vehicle. The speed of the front swing of the vehicle is relatively large when turning, so when the front of the vehicle is close to other objects, it must be slow to drive or turn to prevent collision.

(2) Reckless driving is strictly prohibited

Attention!

- Do not start, brake or steer suddenly. Sudden starting or braking will cause the cargo to fall. Making a sudden turn when driving can cause the vehicle to flip over and cause a serious accident. Slow down and turn carefully.
- Follow all safety regulations on the job site, slow down and honk your horn when driving past other trucks or vehicles. Don't drive in a bad line of sight.
- Make sure there is a gap between the vehicle and the entrance and exit.

(3) Do not drive by the roadside;

Attention!

Make sure there is enough distance between the vehicle and the curb or edge of the platform. When driving on a narrow road or platform, keep a certain safe distance from the edge to prevent the vehicle from falling.



Warning: Do not steering or loading on ramps, otherwise the car will be in danger of tipping over.

3.3 Operation Specifications

Attention!

The vehicle can only carry the goods below the rated weight.

- 1) Overload work is prohibited
- 2) Partial load handling is prohibited
- 3) No passengers on vehicle
- 4) Do not suddenly operate the handle
- 5) Do not use the vehicle as a tractor
- 6) The driver should be especially careful when handling ultra-wide goods, turn slowly, the goods should be balanced, the lifting should be slow, and pay attention to the safety around.
- 7) The faulty repaired vehicle should be parked in a place that does not prevent traffic. The fork is lent to the lowest position, and a warning sign is hung, and the key is removed.
- 8) When protective equipment such as door frame protective cover is not installed, the machine cannot be operated.
- 9) Pay attention to avoid wind hazards when loading

3.4 Precautions after work

1) Parking: Park the vehicle in the designated place. It is forbidden to park the vehicle on the slope.

Do the following before leaving the vehicle:

- a) The fork is naturally lowered to the lowest position;
- b) The steering wheel hits the middle position;
- c) Turn off the key switch.

2) Cleaning the vehicle:

Attention!

Use compressed air to clean the car's electrical system. Do not use water to clean the electrical system.

3) Charging:

Keep a record of charging. Refer to the Battery operation section for charging methods.



Warning: There can be no open flame in the charging station, otherwise it will cause an explosion or fire.

4. Instructions for use and operation

A. Magnetic movable key

The stacker is opened by inserting a magnetic key into the hole. After inserting the magnetic key, the panel LED lights up (as shown in Figure 1). Turn off the stacker by removing the magnetic key. Always turn off the key when leaving the stacker.

B. Emergency reverse

If you touch the reverse switch while working at close range, the forklift will move in the direction of the front fork (as shown in Figure 1). An emergency reverse cannot prevent all injuries.

C. Drive slowly

Press the turtle switch on the control handle and turn the forward/backward rocker arm. (As shown in Figure 1)

D. Electricity

Show the remaining power (as shown in Figure 1)



Figure 1

E. Power off

Press the red scam switch to disconnect the battery and cut off all power (as shown in Figure 2). Whenever the stacker does not work properly, disconnect the battery. The key switch won't cut off all power to the stacker. If the stacker is not working properly, do not use it and report the problem to your supervisor.

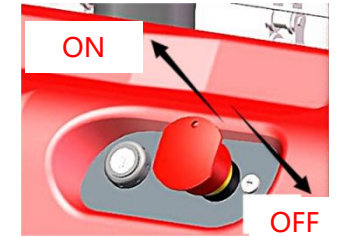

Figure 2

F. Braking

When the handle of the vehicle is in use, the handle can be used normally in the section B through the micro switch. In order to ensure the safety of users, the handle cannot be used normally in the section A and C. (as shown in Figure 3)

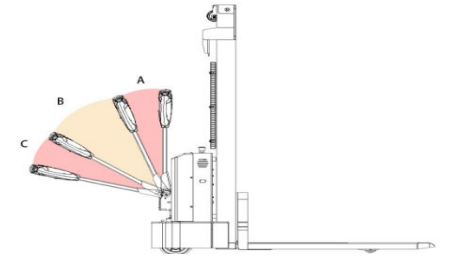

Figure 3

G. Brake control

If you must move the stacker in a narrow area, place the handle in the brake area and press the turtle speed switch (as shown in Figure 4). When the indicator light is red, turn the forward/backward button to the slow driving position.

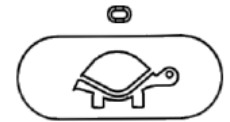

Figure 4



Know the danger

Make sure your brakes work
Test the brakes on the stacker at the beginning of each trip.



H. Lifting or lowering

Push the lifting button (as shown in Figure 5) until the front fork reaches the desired height and then release the button.

I. Horn

For warning reminders (as shown in Figure 5)

J. Turning

You can control the steering by moving the control handle from side to side. For example, this diagram shows the direction the stacker can turn when the control handle is moved to the approximate position shown (as shown in Figure 6).



Know the danger

a. Drive steering

Turn carefully when driving the stacker. The power plant will swing in the opposite direction. Make sure you have space and be aware of people in the area. (as shown in Figure 7)

b. Slippery ground, slow driving

Powder or liquid spills can lead to slippery floors. Slow down or you may lose control of steering and braking. Be careful and allow longer parking distances. Do not run over objects on the floor (as shown in Figure 8)

K. Driving

Push the forward/backward button in the direction you want to travel. The further the button moves from the neutral position, the faster the truck moves. (as shown in Figure 9)

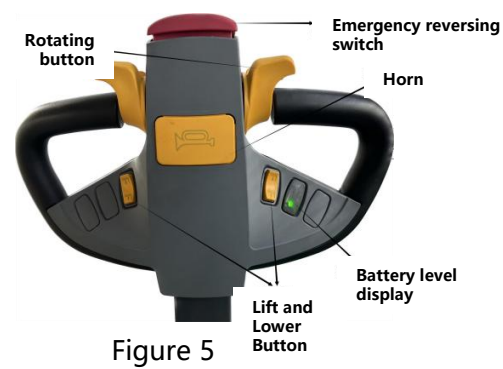

Figure 5

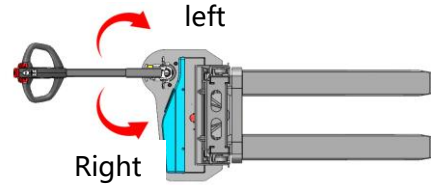

Figure 6

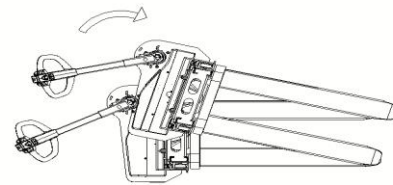

Figure 7

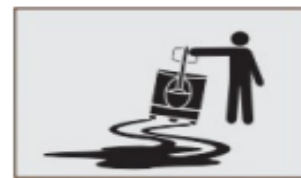

Figure 8



Figure 9

5. Steps for vehicle steering operation

1. Turn the adjusting feet in the picture towards the ground until they can support the ground (note: when adjusting, the heights on both sides should not be too different, otherwise it may cause the forklift to tip over)

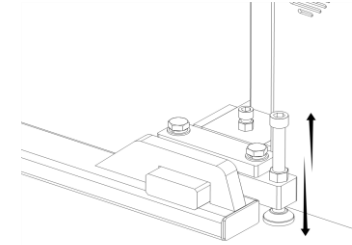

2. Loosen all the fasteners in the picture.

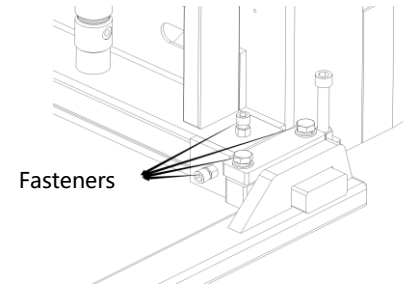

3. Pull the wheels parallel to the arrow direction (the other side operates in the same way), and you can adjust the width of the wheels on both sides.

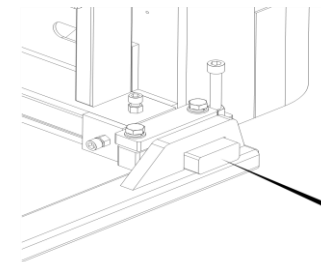

4. Then, tighten all the fasteners in step 2 (the tightening sequence: first tighten two hexagon M16 screws, then tighten two M20 bolts);
5. Adjust the adjustable feet in step 1 upwards without affecting the vehicle's movement.

6. Maintenance

Note: Untrained personnel are not allowed to repair the vehicle

6.1 Whether the vehicle can be used satisfactorily depends on careful maintenance. Neglect of maintenance can endanger personal safety, damage vehicles and property. Therefore, when in use, routine checks should be frequently made to eliminate abnormal phenomena in time. Do not use a faulty vehicle to ensure safety and extend the service life of the vehicle.

6.2 Maintenance: The maintenance of the vehicle is generally divided into three levels, that is, daily maintenance, first-class maintenance, second-class maintenance.

Daily maintenance: Should be carried out once a day. The main content is to keep the body surface clean, clean the battery surface, check whether the power cord is firm and the chain tightness is normal.

First-class maintenance: Maintenance once a week, in addition to daily maintenance content, it should focus on checking whether the work of each component is normal, whether components are loose, whether the chain tightness is appropriate, whether the chain joint connection pin is bent and twisted, whether the inner and outer door frame up and down movement is normal, whether the hydraulic joint oil leakage, whether the mechanical part has abnormal wear, Whether the electrical part has abnormal temperature rise and spark. If found abnormal phenomenon, you should adjust and remove in time.

Second-class maintenance: should be carried out on schedule, and according to the following requirements for a comprehensive inspection of the vehicle.

a. **Mechanical maintenance:** once every six months. The main content is to lubricating the transmission gear and bearing of the drive wheel, adding lubricating oil to the rotating joints, and checking whether the fasteners are tight, whether the wheels are flexible, and whether the fork lift is normal. Clean up the dirt and dust accumulated on the friction plate of the electromagnetic brake, and adjust the gap between the friction plates to the appropriate distance. The vehicle running noise after maintenance is not more than 70 decibels.

b. **Hydraulic maintenance:** every 12 months. Check whether the cylinder is in normal condition, whether there is internal leakage and external leakage, hydraulic joints, hydraulic hose is reliable without leakage phenomenon. Whether the hydraulic oil is clean, usually replace the hydraulic oil once every 12 months. Hydraulic oil adopts ISO oil standard. When the ambient temperature is $-5 \sim 40^{\circ}\text{C}$, HL-N46 or HL-N68 is used, and when the ambient temperature is $-35 \sim -5^{\circ}\text{C}$, HV-N46 or HV-N68 low-temperature hydraulic oil is used. The replaced waste oil shall be disposed of according to the relevant local regulations.

c. **Electrical maintenance:** every three months, check whether the line is loose, remove the dirt, ash, carbon deposits of the motor, check the wear of the brush, and replace the brush as appropriate.

6.3 Adjustment of brake clearance:

① hollow screw ② connecting screw ③ spring ④ armature ⑤ motor shaft ⑥ spline sleeve ⑦ friction plate ⑧ electromagnetic coil ⑨ installation cover ⑩ installation screw

The structure of the brake is shown in the figure. After the vehicle is used for a period of time, the braking performance of the brake will decrease with the wear of the brake disc, or the brake disc cannot be released when it is locked, so the brake gap needs to be adjusted. As shown in the figure, in the braking state, first check the gap between the brake disc and the magnetic steel with a gauge, if the gap is greater than 0.5mm, it is necessary to adjust the gap, and the dirt and dust on the friction disc should be cleaned before adjustment. When adjusting, first loosen the connecting screw ②, then adjust the length of the adjusting screw ①, and then tighten the fastening screw, after adjustment, the gap between the brake disc and the magnetic steel should be between 0.2-0.3mm. When adjusting, pay attention to the balanced adjustment of the three adjusting screws, so that the gap between the brake disc and the magnetic steel is uniform around the adjustment. After adjustment, switch on the brake with 24V DC power supply, you should be able to hear the crisp sound of the brake.

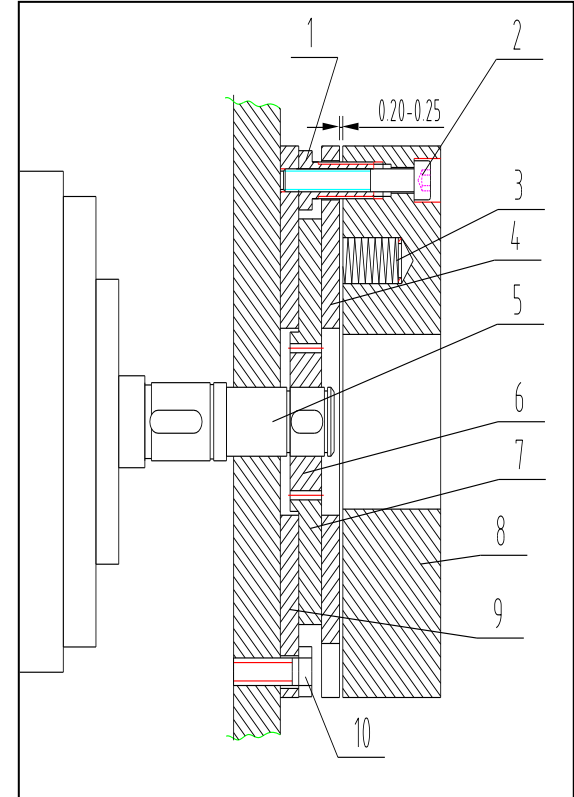

7. Common faults and troubleshooting methods

Serial number	breakdown	reason	solutions	
1	The stacker will not start (the contactor will not work)	① The fuse wire of the control circuit has been burned out	Replace	
		② The power switch is in poor contact or damaged	Repair or replace	
		③ The fuse of the main circuit has been blown	Replace	
	The stacker won't move (Contactor operation)	④ The electric lock switch is in poor contact or damaged	Repair or replace	
		⑤ The battery connection is loose or disconnected	Screw down	
		① The magnetic brake beside the driving wheel is not sucked, and the vehicle is in the braking state	Repair or replace	
② The carbon brush of the walking motor is worn or the commutator is in poor contact with the carbon brush		Repair or replace		
③ The excitation coil of the traveling motor is broken or the line end is in poor contact		Repair or replace		
2	Stackers can only go forward (or backward)	④ Poor contact of contactor	Repair or replace	
		⑤ The MOSFET tube circuit board is faulty	Repair or replace	
3	Stackers can only go forward (or backward)	① The contactor is in bad contact or burned out	Repair or replace	
4	The stacker cannot stop while it is running	② The circuit board is faulty	Repair or replace	
		The contactor contact is damaged and the moving contact is out of position		Cut off the power supply and replace the contactor contact
		① Mounting bolts of microswitches are loose or damaged	Adjust or tighten the bolts, or replace the microswitch	
5	Brake failure	② The parmagnetic brake wiring is loose or the parmagnetic brake is damaged	Tighten the bolt or repair the parmagnetic brake	
		③ parmagnetic brake disc wear	Replace disc	
		① Steering gear bearing damage	Change bearing	
6	Steering jam	② Steering gear bearing lack of oil or too much sticky dust	Clean bearing	
		The driving wheel steering is heavy, there is noise, and the motor is in an overload state		① Gear and bearing have foreign bodies stuck Clean or replace bearings
7	The fork does not rise	② Bearing installation gap, or ring off	Ring off, reinstall, adjust the gap	
		③ Front wheel bearing damaged	Change bearing	
		① overload use	Load reduction	
8	The fork does not fall after it rises	② The relief valve pressure is too low	Turn up	
		③ The lifting cylinder has abnormal internal leakage	Replace seal	
		④ Hydraulic oil is not enough	Add appropriate amount of filtered hydraulic oil	
		⑤ Battery voltage is not enough	Battery charging	
		⑥ The control hand is not in the horizontal or vertical position, and the oil pump motor is not powered	Improper operation	
		⑦ oil pump motor damage	Repair or replace	
		⑧ Oil pump damage	Repair or replace	
		⑨ The lift button switch is damaged	Repair or replace	
		⑩ Electric lock not opened or damaged	Repair or replace	
		⑪ Battery voltage is seriously insufficient	charging	
9	The fork does not fall after it rises	① Overload deformation of the inner door frame	Repair or replace	
		② The outer door frame is overloaded and deformed	Repair or replace	
		③ The door frame roller is stuck	Repair or adjust	
		④ The portal frame guide rod is bent	Repair or adjust	
		⑤ The oil return hole is blocked	Clean	
		⑥ Solenoid valve of hydraulic station is out of control	Troubleshoot the solenoid valve	

8.Schematic diagram Hydraulic schematic diagram

