

EKKO

MATERIAL HANDLING EQUIPMENT

MOVING **AHEAD**

LITHIUM POWERED STRADDLE STACKER EB13E-Li SERIES

- Lithium Battery
- 2800 lbs. Capacity
- Lift Height: 119" | 138" | 145"
- Narrow Aisles 7 ft.
- Adjustable Legs 45.5-59.1 in.
- Adjustable Forks 8.3-33.5 in.
- 24V Drive Motor
- Curtis Instrument Controller
- Lithium Batteries and Charger Included
- 3 Year Limited Warranty



EB13E-Li | EB13E-138Li | EB13E-145Li

Superior quality, maneuverable, compact, and durable for all your material handling applications. Ideal for small aisles and areas.

WEIGHT CAPACITY: 2800 lbs. @ 24" load center

LIFT HEIGHT: 119" | 138" | 145"

FORK LENGTH: 45.3"

ADJUSTABLE OUTRIGGERS: 45.7" - 59.1"

ADJUSTABLE FORKS: 8.3" - 33.5"

MAST HEIGHT: 82" | 92" | 96"

TURNING RADIUS: 52.6"

BATTERY / CHARGER: Lithium-Ion Phosphate
24V/50Ah, internal direct connect 110A 110VAC plug-in automatic 24V/15A charger (both included)

SPEED TRAVEL: 3.3 mph empty; 3.0 mph loaded

LIFTING SPEED: 5.35 ips empty; 3.6 ips loaded

LOWERING SPEED: 3.85 ips empty; 4.4 ips loaded

DRIVE WHEELS: 9" x 3" polyurethane

STABILITY: 4" x 2" polyurethane

LOAD WHEELS: (2) 4" x 3" polyurethane per outrigger

HYDRAULICS LIFTING MOTOR: 24V 2200 Watt lifting motor with hardened chrome moly steel for durability.

DRIVE MOTOR: 24V 750Watt drive motor for efficiency and high torque.

AC CONTROLLER: 24V CURTIS Instrument provides performance through entire range of speed; Constant travel speed regardless of load; Battery discharge indicator combination gauge.

BRAKES: Electro-magnetic braking for secure stopping power; Electronic neutral braking for accurate control.

OPERATOR CONTROLS: Throttle, lifting, lowering, turtle mode and horn functions are located in the ergonomic handle; Belly button reverse safety feature allows the unit to stop and reverse to avoid collision or injury.

CHASSIS AND MAST: Robotic Welding; Heavy duty steel chassis with I-beam mast for durability; Telescoping mast includes a protective steel guard.



Lithium Straddle Stacker

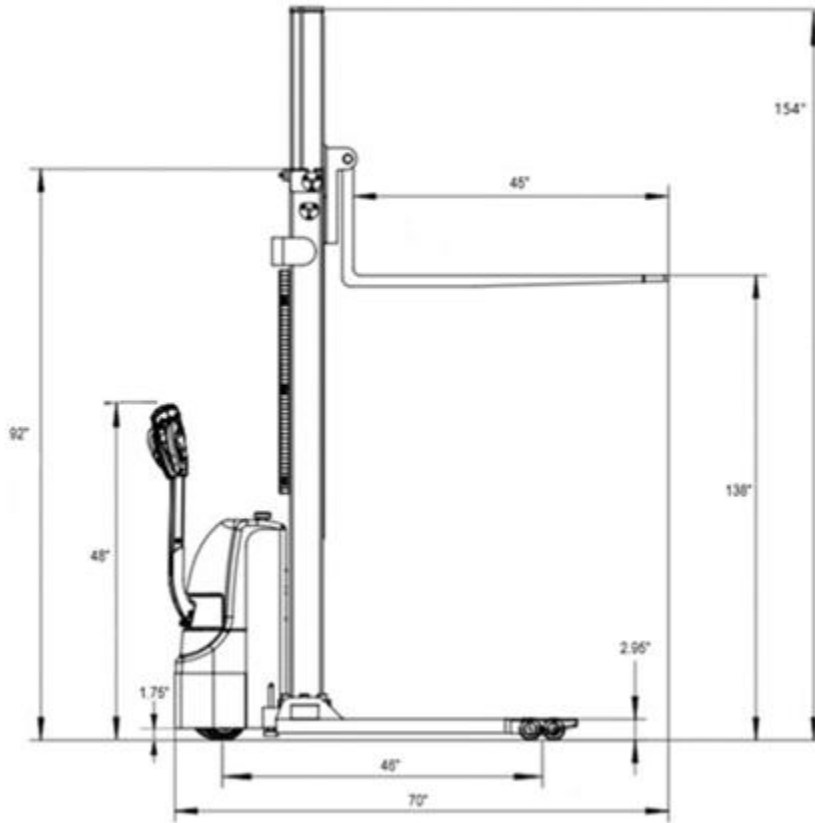

MODEL #	MAST	LIFT HEIGHT	MAX MAST HEIGHT	SERVICE WEIGHT
EB13E-Li	82"	119"	135"	1325LBS
EB13E-138Li	92"	138"	159"	1365LBS
EB13E-145LI	96"	145"	167"	1390LBS



1761 W. Holt Ave.
Pomona, CA 91768 USA
T: (877) 232-6517 F: (909) 222-6861

AUTHORIZED DEALERS ONLY
www.ekkolifts.com