



Operations & Maintenance Manual

Lithium Reach Stacker

ER15-138LI/177LI/189/216LI



Instructions for use

Please read this manual carefully and operate the vehicle safely.

- Do not operate this vehicle without training.
- Please comply with ISO3691 “Safety Specification for Motor Vehicles Industry”.
- Please do not modify or change the repair parameters, including adjusting the pressure. Any loss or damage to the vehicle resulting from such actions will be your responsibility, and doing so will void our warranty commitment.

SPECIAL WARNING:

The company is committed to innovation and sustainable development. As part of this commitment, we continually improve the technology of our products. Therefore, we reserve the right to make changes and improvements to any product described in this specification without prior notice.

1. Overview

The scissor electric stacker (hereinafter referred to as "stacker") The scissor-type electric stacker uses batteries as its power source and is suitable for operations in narrow aisles and limited spaces. It is an ideal tool for the warehousing and logistics industry.

1.1 Main parts and components.

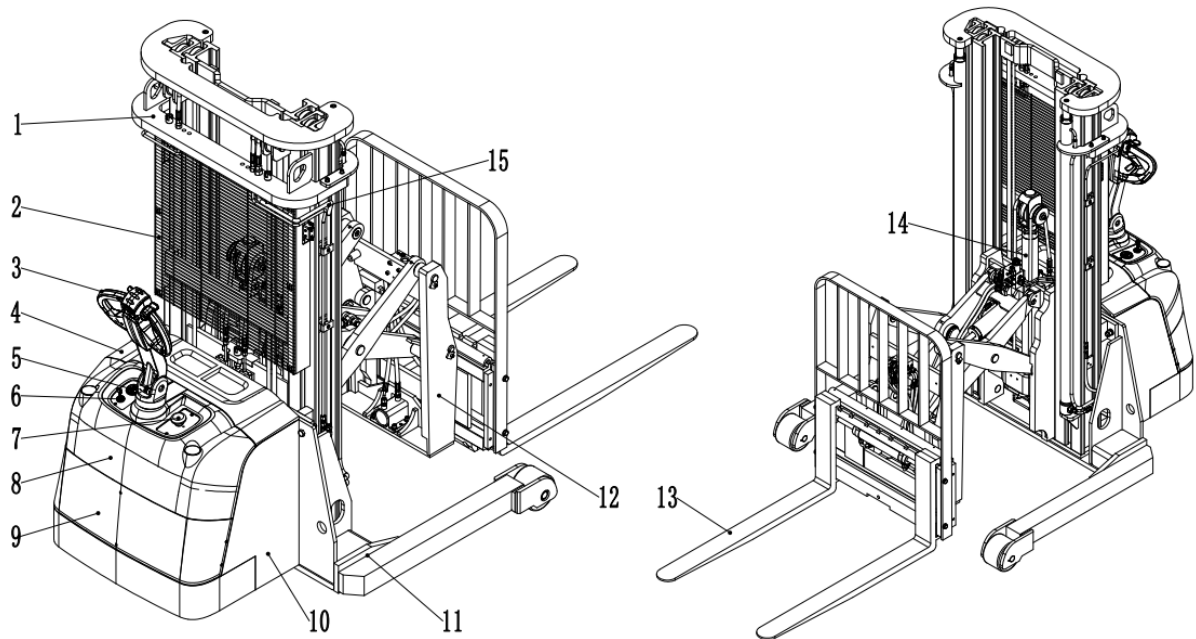

No.	name	No.	name	No.	name
1	Mast	6	Key switch	11	Leg
2	Protective baffle	7	Emergency stop	12	Lifting platform
3	Operating handle	8	COVER	13	fork
4	Battery cap	9	COVER	14	Oil cylinder
5	ammeter	10	body	15	Oil pipe

1.2 Permissible use conditions

- The stacker is only used in the warehouse, work areas, factories and other suitable locations
- Use only on flat surfaces with adequate load-bearing capacity.
- May only be used on roads with good visibility and where the driver has a clear view of the road ahead.
- Use within specified rated load.
- When used within the rated load, the lifting platform should be closed.
- The average ambient temperature under continuous operation conditions was +77°F
- The maximum ambient temperature for stacker in the short term (1h) is + 104°F.
- The minimum ambient for stacker under normal indoor conditions is + 41°F
- The minimum ambient temperature for using stacker under normal outdoor conditions is -4°F
- Maximum elevation 6,560ft
- Maximum climb at full load is 6%
- Do not walk sideways or diagonally when going uphill. When the goods are going uphill, the forks must be kept forward; when the goods are going downhill, the unit should be moved backwards.

1.3 Obligations and Responsibilities of the Equipment User

Equipment User Defined

In this instruction manual, "equipment user" refers to any customer or dealership who directly uses or entrusts others to use the stacker. In the special case of renting, selling or leasing, the "user of the equipment" is the party who has specific operating obligations under the terms of the contract between the owner and the user of the equipment.

User Responsibilities

The user of the equipment must ensure that the stacker is used only for its intended purpose and that all dangers that may endanger the life and health of the user or third parties are promptly addressed. In addition, users of the equipment must strictly comply with accident prevention regulations, other safety technical regulations, and equipment operation, maintenance and repair instructions. The user of the equipment must ensure that all operators carefully read and fully understand the contents of these operating instructions.

Operator Training

All operators must carefully read and fully understand the contents of this operating instruction. Failure to follow these instructions will automatically void our warranty.

Unauthorized Modifications

If customers and/or third parties perform abnormal operations on the equipment without permission from the company's customer service department, the company does not assume any responsibility for the resulting losses.

1.4 Installing Fittings or Modifying the Vehicle

Installation Accessories: Additional devices that need to be installed or added, such as affecting or supplementing the functions of the forklift, must obtain the company's written consent in advance. Depending on the actual situation, it may also be approved by the local competent authority.

The review results of the competent authorities do not represent the opinions of the company.

2. Main Technical Parameters and Characteristics

2.1 Schematic Diagram

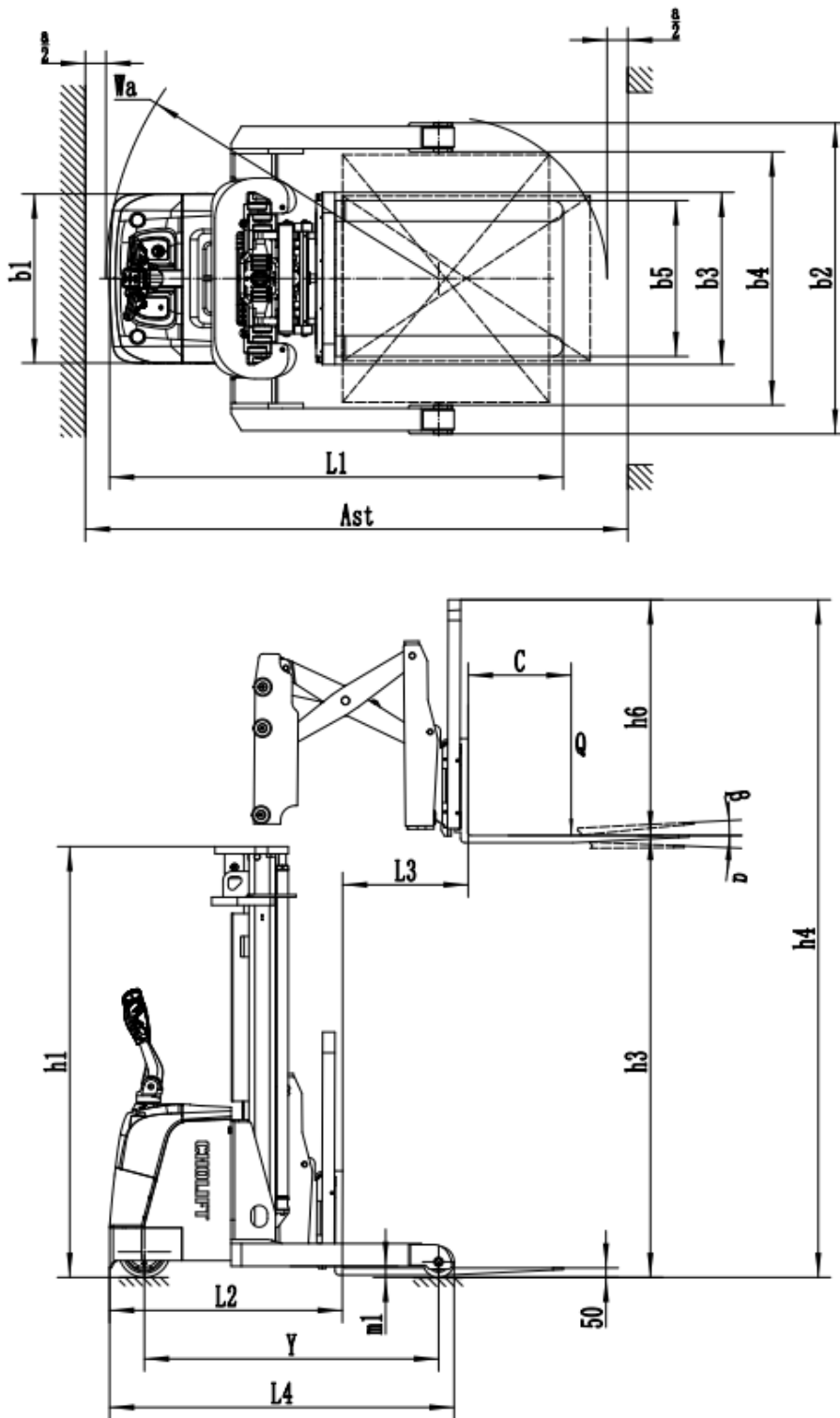

2.2 Technical Data of Standard Specifications

Feature	1.1	Model		ER15 138/177/189/216
	1.2	Driving mode		Electric power
	1.3	Driving mode		Stand
	1.4	Rated load	Q(lbs.)	3,300
	1.5	Load center distance	c(in)	20
Weight	2.1	Service weight (with battery)	lbs.	6,173
Wheel	3.1	Wheel material		Polyurethane wheel
Size	4.1	Lifting height	h3(in)	138/177/189/216
	4.2	Height when gantry is lowered	h1(in)	83
	4.3	Maximum vehicle height during operation	h4(in)	225
	4.2	Lower hour height	h13(in)	1.9
	4.3	Total length	l1(in)	86.6
	4.4	Overall width	b1(in)	32.28
	4.5	Fork size	S/e/l(in)	1.4/3.94/42.2
	4.6	Outer width of forks	b5(in)	10.23
	4.7	Minimum body clearance	m1(in)	2.12
Function	4.8	Turning radius	Wa(in)	63.38
	5.1	Travel speed, full/empty	Mph	2.17/2.48
	5.2	Lift speed, full load/no load	in/s	3.93/7.87
	5.3	Descent speed, full load/no load	in/s	7.87/3.93
	5.4	Climbing capacity, loading/unloading	%	6/10
Motor	5.5	Service brake	electric motor	Electromagnetic
	6.1	Drive motor power	kW	1.5
	6.2	Boost motor power	kW	4
	6.3	Battery voltage/rated capacity	V/Ah	24/210 24V/280
other	6.4	Battery weight	kg	
	7.1	Noise level at driver's ear meets DIN12053	dB(A)	<70

*The technical data given above are all standard data, and the company reserves the right to make technical changes and supplements.

2.3 Location of Product Signs and Warning Signs

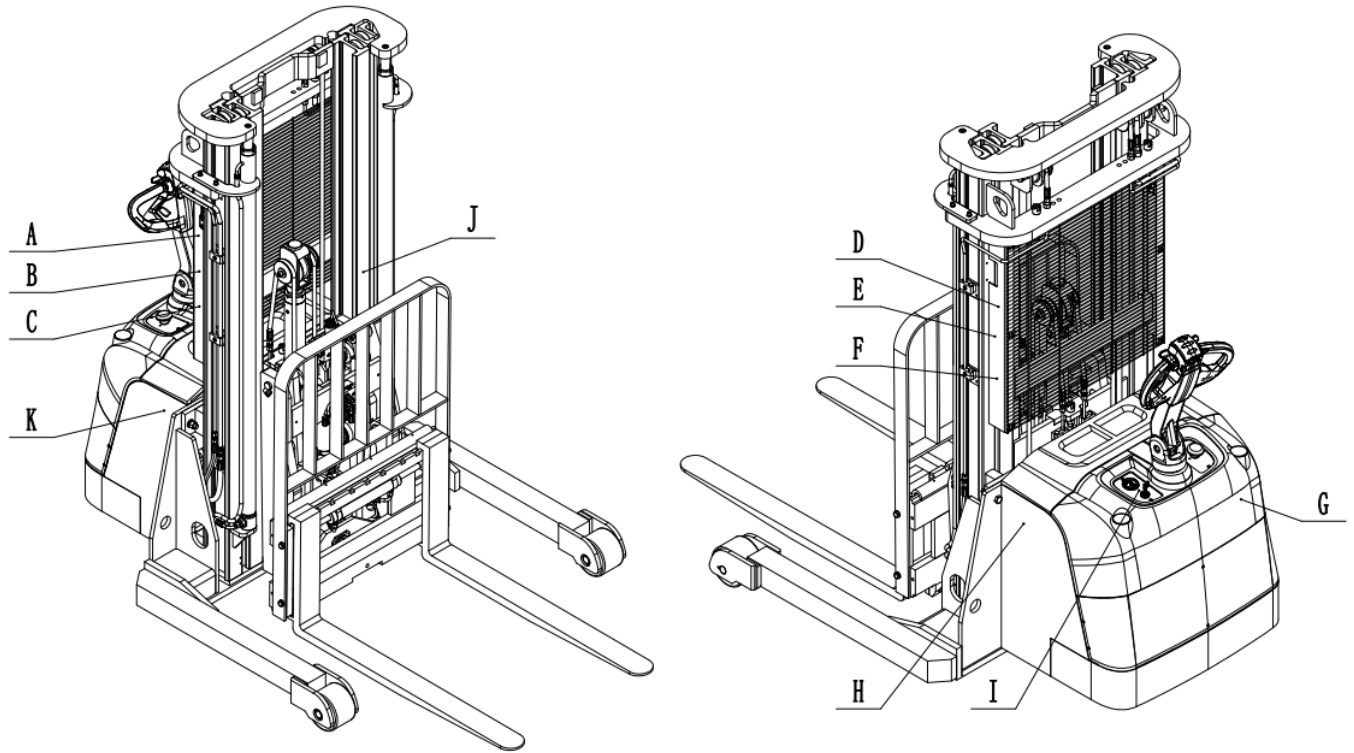

No.	Name	QTY	No.	Name	QTY
A	Hook mark	1	G	Manufacturer logo	1
B	Prohibited to stand under the fork	1	H	Daily use and maintenance of electric stacker	1
C	No people on the fork	1	I	Insufficient power prompt label	1
D	Load curve	1	J	Cut off warning labels	2
E	Load center	1	K	Instructions for using electric stacker	1
F	Nameplate	1			

3. Lifting, Fixing and Transportation of Vehicles

As a short-distance handling and loading and unloading tool in the field (factory), stacker is not suitable for long-distance driving. If the stacker truck is to be transported over long distances, the stacker truck can be prevented from being transported on long-distance transport vehicles such as trucks and trailers through the cargo handling platform of the lifting device.

3.1 Lift

- Use professional cranes and lifting equipment.
- Do not stand under the stacker when lifting it.
- Lifting or lowering should be smooth and slow to avoid collision or safety accidents.
- Turn off the key switch and the red emergency power-off switch, lower the fork to the lowest position and be level with the ground, and close the fork frame.
- When parking the forklift for an extended period, ensure the tires are straight and charge the battery at least once a month.
- Adhere to the lifting guidelines indicated on the forklift's lifting label. Do not transport or pick up the stacker while the mast is extended.

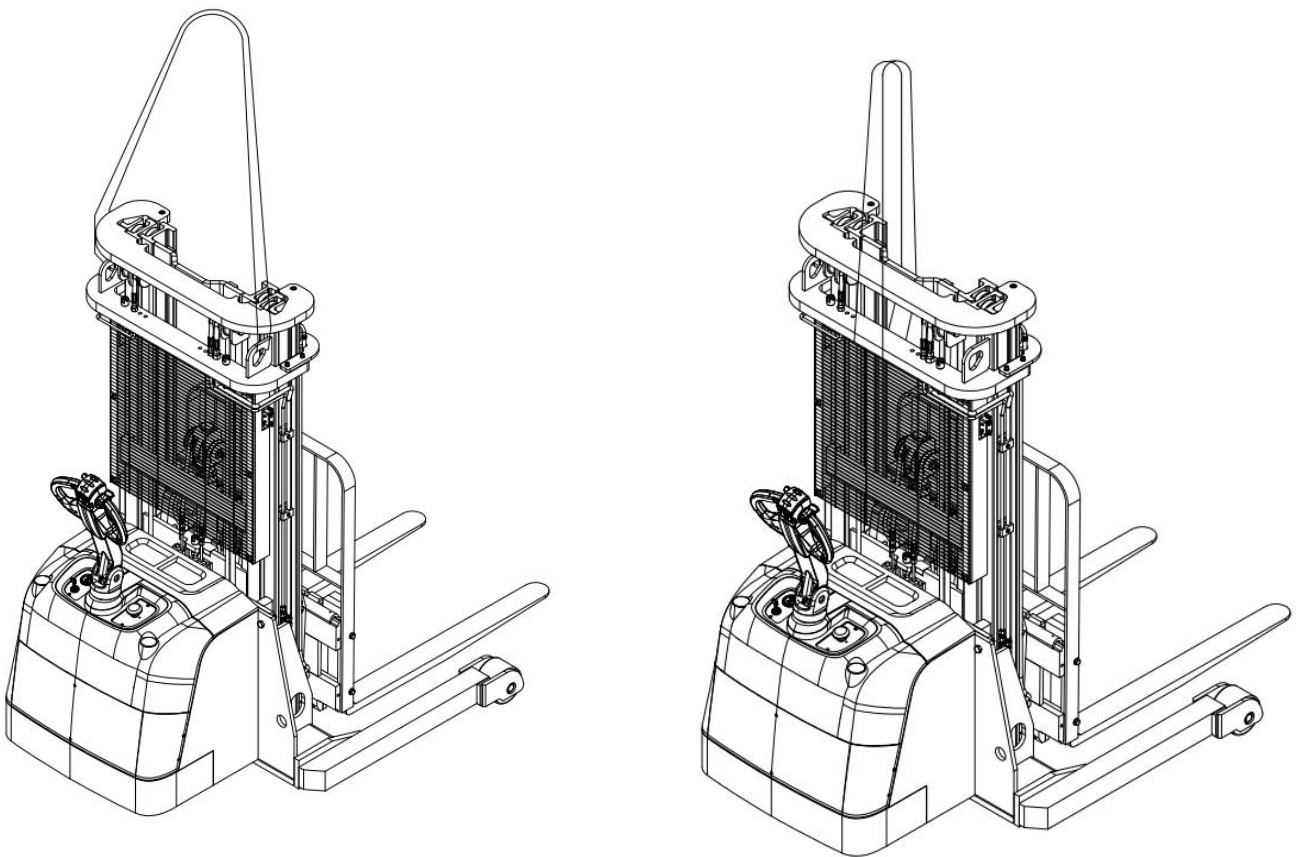

3.2 Fixed Position during Transportation

Lower and stow the forks and park the vehicle safely. Move the frame back into place and turn off the power.

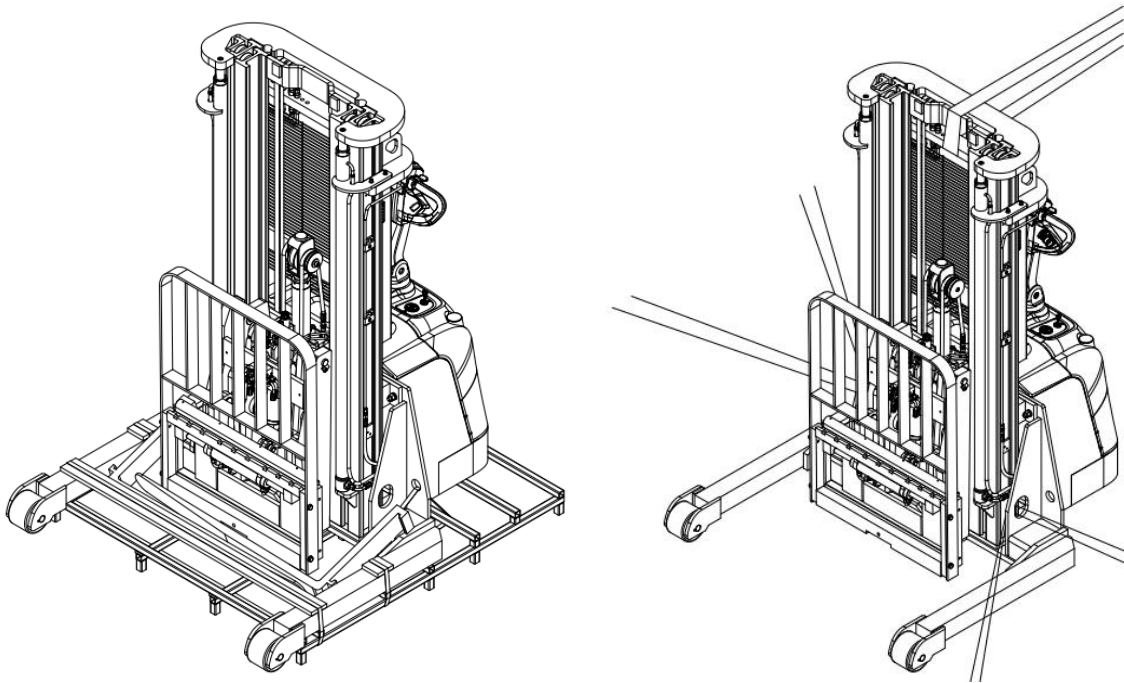

3.4 Transportation

As a short-distance stacking tool in the yard (factory), the fork-type reach stacker is not suitable for long-distance travel. In order to transport a stacker over long distances, it needs to be securely attached to a van or truck. During transportation, the frame and top guard frame are fixed with steel wire ropes, and wedges are placed at the corresponding positions of the front and rear tires to ensure they are firmly wedged.

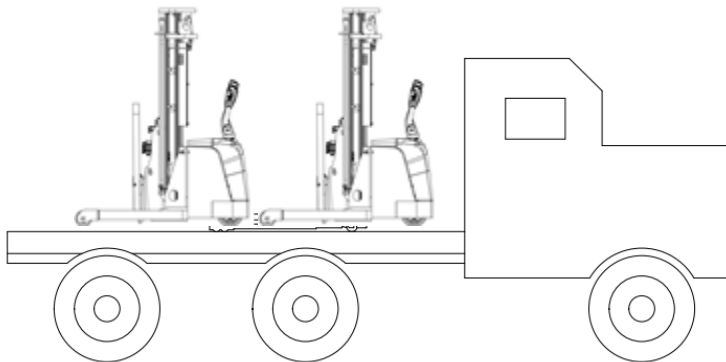

4. Operation and Maintenance Guidelines

This vehicle must be operated and maintained in accordance with the instructions in this manual. Proper use and operation of the vehicle will bring great convenience to your work. Use of the vehicle for any other purpose is illegal and may result in injury or death, damage to the forklift or other property.

4.1 Check Before Operation

- Leakage check
 - Check for leaks such as hydraulic fluids on the ground surrounding the parked lift.
- Fork Inspection
 - Check whether the forks are cracked or bent.
- Wheel Inspection
 - Check the wheels for cracks, damage or unusual wear. Check whether wheel fasteners are loose. Check for obstructions or foreign objects around the wheels.
- Mast Inspection
 - Check whether the mast is deformed, or the chain is loose.
- Hydraulic Oil Inspection
 - Open the back cover, check whether the oil level is between the specified range. If it is insufficient, add more.
- Battery Inspection
 - Check whether the battery is well secured. Check whether the terminal cables are loose or damaged.

4.2 Start

- Instrument Inspection
 - Pull up the emergency stop button and turn the key switch clockwise to check whether the meter power display is normal

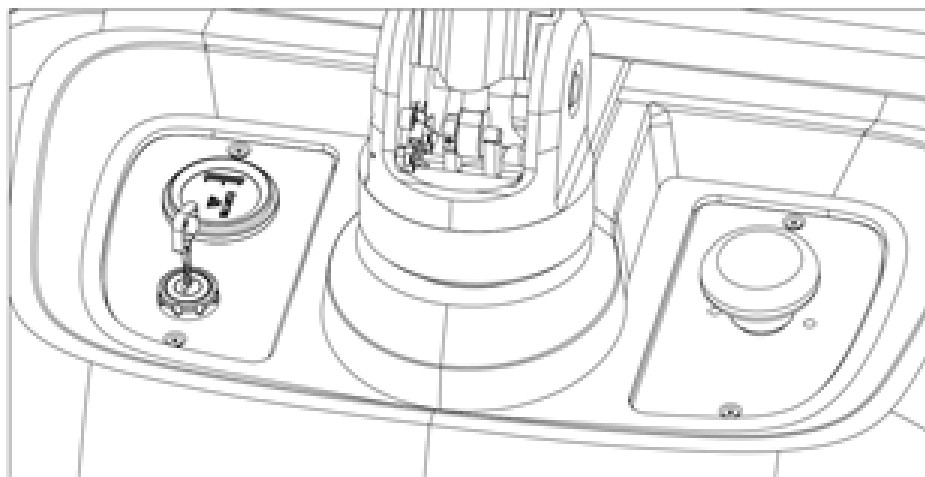

- **Lift Check**

- Push the lift button to check the fork lift condition. Push the descent button to check the fork drop. Listen to the system for any abnormal sounds.

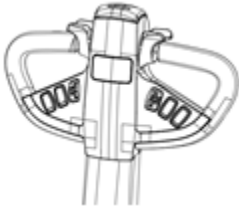

- **Forward and Backward check**

- Press the handle to the driving state, rotate the accelerator towards the body with the thumb, and observe the vehicle's direction of travel.

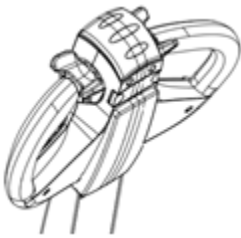

- **Fork extension and retraction inspection**

- Push the forward and backwards button to check the extension and retraction of the forks. Listen for any abnormal sounds.

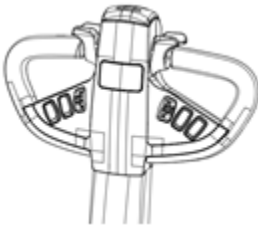

- **Side Shift Check**

- Press the right and left movement button to check the movement of the forks.

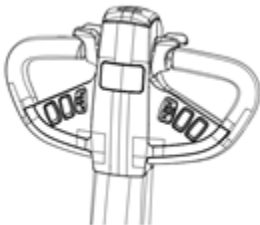

- **Steering Check**
 - While driving, turn the steering wheel left or right and check if the steering response is normal.
- **Horn Inspection**
 - Honk the horn to check for sound

4.3 Handle Function Description

Before use, you must carefully read the operation and maintenance manual and related documents and be familiar with the location of the instruments and control buttons.

NO.	NAME	FUNCTION
1	Move button	Press the button to move the upper part to the left and the fork to the right
2	Tilt button	Press the button to tilt the upper part of the fork back, otherwise the fork tilts forward
3	Up and down button	Push the button up and the fork rises and vice versa
4	Horn button	Press the horn button to make a drip sound
5	Emergency reverse button	When you press the button, the stacker goes in reverse
6	Move back and forth button	Push the button down to move the fork forward and vice versa
7	Forward and backward accelerator	Rotate the vehicle backwards in the direction of the body and forward in the opposite direction
8	Turtle mode	Long press the button and rotate the accelerator, the handle in the upright state can also drive slowly

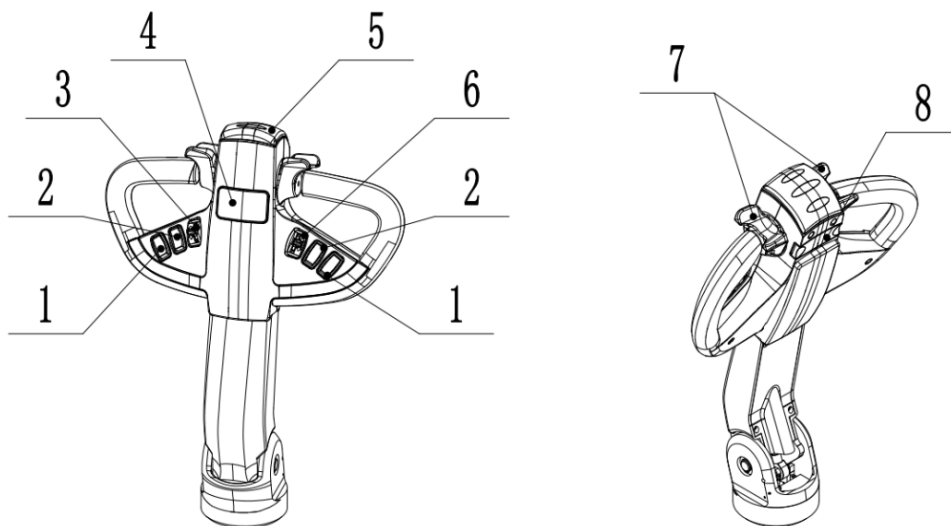

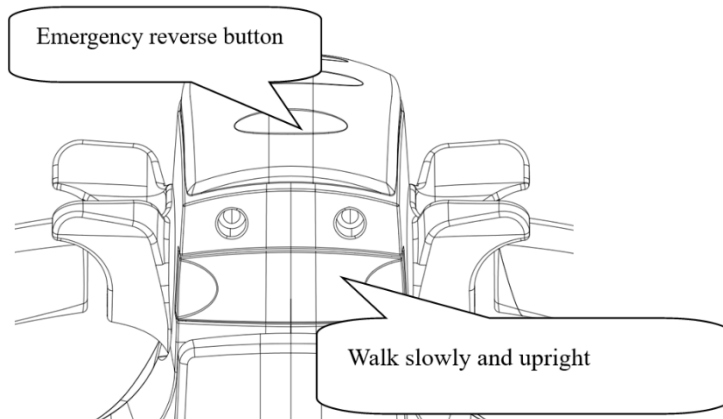
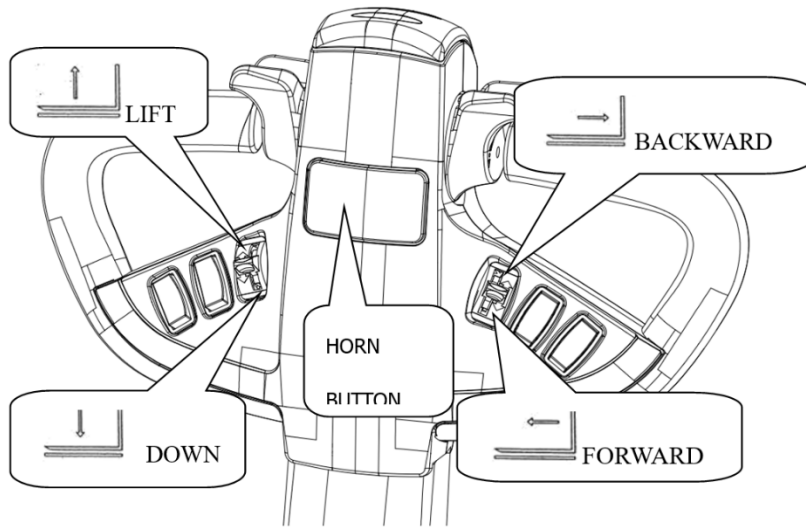
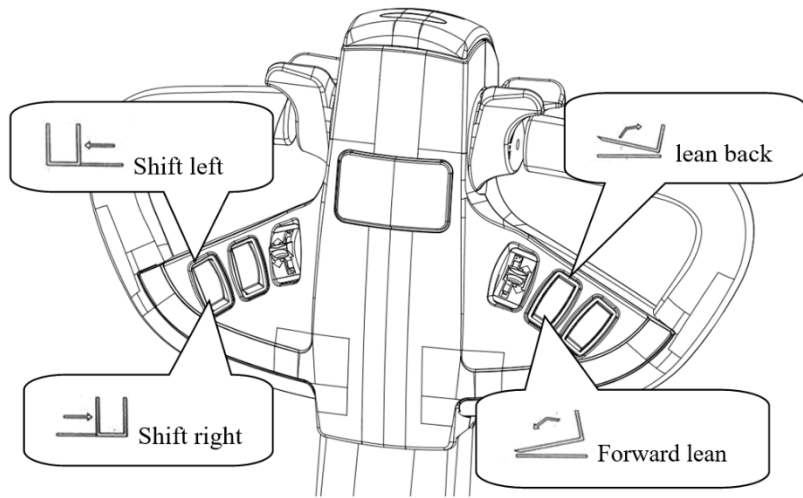

4.4 Brake

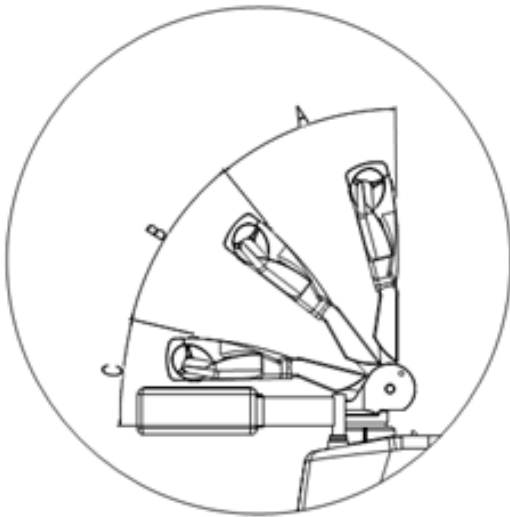

The rudder handle is divided into three sections A, B and C in the vertical plane, and the two zones A and C are the braking zones.

When the rudder handle is located in zone A or zone C, the vehicle is in the braking state.

If the rudder handle is located in area B, the vehicle is in normal running condition.

Danger: Forklift is strictly prohibited on the slope.

- Acceleration and Deceleration

The accelerator has a stepless speed regulation function, and the amplitude of the accelerator rotation determines the speed of travel.

When you spin clockwise or counterclockwise, it will determine the forward and backward direction of the vehicle.

- Lift and fall/forward and back

Lifting and falling, the fork forward and backward are equipped with proportional speed regulation function, push the button amplitude, determine the speed of rising and falling and forward and backward.

- Emergency Stop



When the forklift is in a variety of emergency situations, the emergency stop button should be pressed immediately.

5. Precautions for Forklift Operation

5.1 When using, attention should be paid to the performance and working status of machinery, hydraulics, electrical and speed regulators.

5.2 Pay attention to the power level of the meter. When the meter's power is lower than the last bar, you should stop working immediately and charge the battery or replace it with a battery with sufficient power.

5.3 The load should not exceed the specified value during transportation. The distance and position of the forks should be appropriate. The forks should be inserted under the goods to evenly distribute the weight on the forks to avoid unbalanced loading.

5.4 Start, turn, brake and stop smoothly, slow down when turning.

5.5 No one is allowed to stand under the fork, and no one is allowed to be lifted on the forks.

5.6 When the mast is lifted for loading, the cargo forks must be retracted first and then lowered to avoid falling too fast and shifting the center of gravity, causing the rear mast to warp.

5.7 When loading and driving, the goods should be lowered as much as possible, the forks should be tilted backward and moved into position, and driving and rotation should not be allowed when the mast is raised.

5.8 When driving, pay attention to pedestrians, obstacles, potholes, and the space above the forklift.

5.9 The forklift should avoid emergency braking when driving with load.

5.10 When leaving the stacker, lower the forks to the ground, close the forks, and disconnect the power supply.

5.11 The pressure of the forklift multi-way relief valve has been adjusted before leaving the factory, and users are not allowed to adjust it at will during use.

5.12 The chain should be checked regularly during use to ensure the safety of the load.

5.13 The maximum noise value outside the stacker truck shall not be greater than 80dB(A), and the test method shall be carried out according to JB/T3300 standard.

6. Charging the Battery

6.1 When charging and recharging the battery for the first time, the provisions of this manual should be strictly followed.

6.2 When the forklift is working, when the battery voltage drops to 41V, or the voltage of any single battery drops below 1.7V, or the instrument alarms, the forklift should stop running immediately and continue to use it after charging or replacing the battery.

6.3 Check the electrolyte specific gravity, liquid level height and temperature at any time during charging.

6.4 After using the forklift, the battery must be charged as soon as possible and left for no more than 24 hours when charging to prevent undercharging and overcharging, to avoid damaging the battery.

6.5 For charging methods and maintenance, refer to the battery operating instructions.

7. Care and Maintenance

This chapter outlines the necessary maintenance tasks to ensure your stacker operates safely and efficiently. Regular inspections and maintenance will prolong the life of your stacker. Even if your stacker is not in use for extended periods, it's essential to conduct routine checks.

Lubrication: A Crucial Component

Proper lubrication is vital for maintaining mechanical efficiency and preventing premature wear of parts. Neglecting lubrication can hinder the stacker's normal operation. Therefore, regular lubrication is essential.

Stacker Maintenance: A Priority

Adhering to daily maintenance guidelines can help prevent issues and ensure your stacker operates smoothly.

Safety First: Important Precautions

Warning: Before performing any maintenance work, disconnect the battery plug and prominently display a warning sign on the stacker.

7.1 Daily Maintenance Table

a. Battery

Inspection item	Maintenance requirements	Daily (8h)	Weekly (50h)	Monthly (200h)	Every 3 months (600h)	Semiannually (1200h)
battery	Check acid concentration, liquid level and battery voltage		•			
	Check if the battery voltage is low	•				
	Check whether the terminal is fixed, whether the cable is loose			•		
	Clean foreign matter on the surface promptly	•				
	Is the battery cable damaged?			•		

b. Controller

Inspection item	Maintenance requirements	Daily (8h)	Weekly (50h)	Monthly (200h)	Every 3 months (600h)	Semiannually (1200h)
Controller	Whether the plug is aged					•
	Whether the contactor is normal			•		
	Check whether the connection between the motor, battery and drive device is normal			•		

c. Lifting System

Inspection item	Maintenance requirements	Daily (8h)	Weekly (50h)	Monthly (200h)	Every 3 months (600h)	Semiannually (1200h)
Chain and Turbine	Check the chain for rust					•
	Check whether the chain is loose			•		
	Check the chain for deformation and damage					•
Lift cylinder	Check the piston rod and thread connection for loosening, deformation and damage					•
	Check whether the cylinder works properly	•				
	Check for leaks		•			
	Check dowel pins and cylinder blocks for wear and damage			•		
Fork	Inspect the fork for deformation, wear and damage				•	
	Check the fork body and upper slide block for wear and cracks caused by welding defects				•	
Frame and fork carrier	Check for welding defects, cracks and damage between tilt cylinder support and door frame			•		
	Check the fixing of the lifting frame					
	Visual inspection of the roller	•				
	Check the fixing of the lifting frame	•				
	Check the parallelism and side clearance of the gantry column			•		

d. Motor

Inspection item	Maintenance requirements	Daily (8h)	Weekly (50h)	Monthly (200h)	Every 3 months (600h)	Semiannually (1200h)
Motor	Check the wear of the carbon brush					•
	Check motor fixation			•		

e. Driving System

Inspection item	Maintenance requirements	Daily (8h)	Weekly (50h)	Monthly (200h)	Every 3 months (600h)	Semiannually (1200h)
Reduction box	Check for abnormal sound	•				
	Check for oil leaks		•			
	Replace the gear oil					•

f. Wheel

Inspection item	Maintenance requirements	Daily (8h)	Weekly (50h)	Monthly (200h)	Every 3 months (600h)	Semiannually (1200h)
Driving wheel, balancing wheel and carrying wheel	Check for wear and tear	•				
	Check for support and fixation		•			
	Check the tire for foreign objects such as rope	•				

g. Brake System

Inspection item	Maintenance requirements	Daily (8h)	Weekly (50h)	Monthly (200h)	Every 3 months (600h)	Semiannually (1200h)
Brake microswitch	Check the braking status of the control handle in the horizontal and vertical positions	•				
	Check whether the microswitch functions properly			•		
Brake	Whether the installation is firm			•		

	Whether damaged or not				•	
	Clean brake				•	
	Brake sensitivity	•				

h. Hydraulic System

Inspection item	Maintenance requirements	Daily (8h)	Weekly (50h)	Monthly (200h)	Every 3 months (600h)	Semiannually (1200h)
Hydraulic tank	Check the hydraulic oil level and replace the hydraulic oil					•
	Clean the oil suction filter			•		
	Clean the outside			•		
Hydraulic pump	Check whether the hydraulic pump leaks		•			
	Check whether the hydraulic pump is damaged				•	

i. Electrical components

Inspection item	Maintenance requirements	Daily (8h)	Weekly (50h)	Monthly (200h)	Every 3 months (600h)	Semiannually (1200h)
Circuit emergency stop switch	stipulate	•				
Lift and drop button	stipulate	•				
Horn	Check whether the horn works properly	•				
Appearance	Check whether the meter display is normal	•				

Attached table

Replace key parts regularly

Some parts must be inspected regularly for damage, to further improve the safety of the product, users should regularly replace the parts in the table below.

If these parts are damaged before replacement, they should be replaced immediately.

Description of critical safety parts	Use time interval (years)
Hydraulic tubing for lifting system	1-2
Lifting chain	2-4
Hydraulic system high pressure line	2
Internal sealant, rubber products	2
Rigid conductor	1

8. General fault analysis and treatment method of forklift truck

8.1 Transmission System

Problem	Possible cause	Elimination method
The gear is noisy when driving	1. Excessive gear clearance	adjust
	2. Excessive gear wear	replace it
	3. Less oil in gear box	Check fueling
The impact of traffic reversing is loud	1. Excessive gear clearance	adjust
	2. Excessive gear wear	replace it
Gearbox leakage	1. Oil leaks from the drain plug	Adjust and replace gaskets
	2. Motor shaft end oil	Replace the O-ring
	3. Oil permeates the connecting plate and gearbox housing	Check the surface finish and reapply sealant

8.2 Steering System

Problem	Possible cause	Elimination method
Steerless	1. Steering motor does not work	Check power wiring or change, encoder needs to be replaced
	2. The Angle input sensor does not work	Check the power cable or replace it
	3. The Angle limit switch is in poor contact	Adjust
	4. The Angle input sensor does not work	Check the power cable or replace it
Gear noise during steering	1. Excessive gear clearance	Adjust
	2. Excessive gear wear	Replace it
	3. Less grease in gear box	Check for grease
Steering is not flexible	1. Steering bearing stuck	Check the bearing or replace it

8.3 Brake System

Problem	Possible cause	Elimination method
Poor braking	1. The brake overheats	Overhaul
	2. The brake clearance is too large	Adjust
Brake noise	1. The brake is improperly installed	Adjust

8.4 Hydraulic System

Problem	Possible cause	Elimination method
The system has no oil or insufficient oil	1. The pipe or connector leaks oil	Overhaul
	2. Low oil level in the tank	Check fueling
	3. Too much oil impurities, the filter is blocked	Replace the oil and filter
	4. Gear pump wear is too large	Replace
	5. Gear pump oil leakage	Check seal ring or replace
Lifting inability or inability to lift	1. Gear pump wear is too large	Replace
	2. Insufficient system pressure	Adjust the safety valve pressure
	3. The multiway valve and valve stem wear too much	Replace or replace the valve stem
	4. Internal leakage of lifting cylinder	Reseal
	5. The safety valve does not return	Overhaul

	6. The motor does not turn or is weak	Check or replace
	7. The tubing is blocked	Check and replace

8.5 Electrical System

Problem	Possible cause	Elimination method
No signal when the key switch is turned on	1. The key switch is in poor contact	Overhaul
	2. Disconnect the cable	Reconnect
	3. The contacts are not in good contact	Overhaul
	4. The battery connector is loose	Tighten the connection bolt
The rotary accelerator does not walk	1. Disconnect the cable	Overhaul
	2. The connector is in poor contact	Overhaul or replace
	3. The direction switch is in poor contact	Overhaul or replace
	4. The walking electric control fails	Overhaul or replace
	5. The steering electric control is faulty	Overhaul or replace
The lifting motor does not run	1. The contactor coil is disconnected	Contactor change
	2. The lifting switch does not work properly	Overhaul or replace
	3. Disconnect the cable	Reconnect
	4. The connector is in poor contact	Overhaul
	5. The lifting electric control fails	Overhaul or replace
The lifting motor runs often	1. The lifting switch does not work properly	Overhaul
The horn doesn't sound.	1. The connector is in poor contact	Overhaul or replace
	2. The horn connector switch is in poor contact	Overhaul
	3. The speaker is broken	Replace
Honk often	1. Horn switch contact is normal	Overhaul

9. ER15 Reach Stacker Troubleshooting

To ensure your stacker remains in optimal working condition, it must be operated carefully, adjusted, maintained and repaired in time to keep the forklift in good working condition for a long time, and the following measures should be taken:

(1) The gear oil of the gearbox should be replaced after the first 100 hours of work of the new forklift, and the gear oil should be re-tightened and re-tightened.

(2) The clearance of the main and passive gears should be readjusted after the first 200 hours of work.

(3) The motor, electronic control, battery should be maintained according to the provisions of its manual. Therefore, the connector should be checked once a month.

(5) Avoid exposing the stacker to water, avoid washing with water, and avoid outdoor use on rainy days.

(6) The battery surface should be kept clean, and dirt should be removed frequently.

After normal use, the forklift should be regularly maintained according to the following table.

No.	Item	Maintenance content	Maintenance cycle	Remark
1	Drive gear box	Replace the gear oil	1200 hours	
2	Steering gear box	Regrease	1200 hours	
3	Forward cylinder pin	Regrease	100 hours	
4	Tilt cylinder pin	Regrease	100 hours	
5	Door frame forward and backward shift bearing	Regrease	250 hours	Replace any damage at any time
6	Door frame lift and drop bearing	Regrease	250 hours	Replace any damage at any time
7	Hydraulic tank and strainer	Cleanse	1000 hours	
8	Hydraulic oil	Replace	1000 hours	
9	Lifting chain	Replace	3000 hours	Replace any damage at any time
10	High pressure oil pipe	Replace	3000 hours	Replace any damage at any time

Forklift Oil

Name	Brand, code (domestic)	Brand, code (foreign)
Hydraulic oil	32# or 46#	ISOVG30
Gear oil	18# hyperbola	SAE90/SAE80W
Grease	3# lithium base grease drop point 170	Isk-2220, 1#, 2#

1. Fault Alarm and Treatment

- a. When the forklift fails, the electrical indicator will show the alarm fault

2. Common Faults and Troubleshooting Methods

Num	Fault description	Fault cause	Elimination method
1	The stacker will not start (the contactor will not work)	① The fuse wire of the control circuit has been burned out	Replace
		② The power switch is in poor contact or damaged	Repair or replace
		③ The fuse of the main circuit has been blown	Replace
		④ The electric lock switch is in poor contact or damaged	Repair or replace
		⑤ The battery connection is loose or disconnected	Screw down
	Stacker does not move	① The magnetic brake of the driving wheel is not drawn, and the vehicle is in the braking state	Repair or replace
		② The carbon brush of the walking motor is worn or the commutator is in poor contact with the carbon brush	Repair or replace
		③ The excitation coil of the traveling motor is broken or the line end is in poor contact	Repair or replace
		④ Poor contact of contactor	Repair or replace
		⑤ The MOSFET tube circuit board is faulty	Repair or replace
2	Stackers can only go forward (or backward)	① The contactor is in bad contact or burned out	Repair or replace
		② The circuit board is faulty	Repair or replace
3	The stacker cannot stop while it is running	The contactor contact is damaged and the moving contact is out of position	Cut off the power supply and replace the contactor contact

4	Brake failure	① Mounting bolts of microswitches are loose or damaged	Adjust or tighten the bolts, or replace the microswitch
		② The paramagnetic brake wiring is loose or the paramagnetic brake is damaged	Tighten the bolt or repair the paramagnetic brake
		③ paramagnetic brake disc wear	Replacement disc
5	Steering jam	① Steering gear bearing damage	Change bearing
		② Steering gear bearing lack of oil or too much sticky dust	Bearing cleaning
6	The driving wheel steering is heavy, there is noise, and the motor is in an overload state	① Gear and bearing have foreign bodies stuck	Clean or replace bearings
		② Bearing installation gap, or ring off	Ring off, reinstall, adjust the gap
		③ Front wheel bearing damaged	Change bearing
7	The fork does not rise	① overload use	Load reduction
		② The relief valve pressure is too low	Turn up
		③ The lifting cylinder has abnormal internal leakage	Replace seal
		④ Hydraulic oil is not enough	Add an appropriate amount of filtered hydraulic oil
		⑤ Battery voltage is not enough	Battery charging
		⑥ The control hand is not in the horizontal or vertical position, and the oil pump motor is not powered	Improper operation
		⑦ oil pump motor damage	Repair or replace
		⑧ Oil pump damage	Repair or replace
		⑨ The lift button switch is damaged	Repair or replace
		⑩ Electric lock not opened or damaged	Repair or replace
		⑪ Battery voltage is seriously insufficient	Charge
8	The fork does not fall after it rises	① Overload deformation of the inner door frame	Repair or replace
		② The outer door frame is overloaded and deformed	Repair or replace
		③ The door frame roller is stuck	Repair or adjust
		④ The portal frame guide rod is bent	Repair or straighten
		⑤ The oil return hole is blocked	Clear
		⑥ Solenoid valve of hydraulic station is out of control	Troubleshoot the solenoid valve
9	Battery terminal voltage reduction (after charging)	① A single battery is damaged	Repair or replace
		② Battery liquid level is low	Add electrolyte
		③ There are impurities in the electrolyte	Electrolyte change

If the issue persists after following all the steps outlined in the "Solution" section, please contact our customer service department. Further diagnosis and troubleshooting should be carried out by trained after-sales service technicians.

Fault Name	Cause of Fault Triggering	Alarm CAN Code
Current	The current sensor AD value exceeds the sampling range	2311
Precharge Failure	The bus voltage drops below 20% of the voltage specified in parameter 301 within one second of power-up.	3130
Over voltage Fault	Forklift voltage exceeds 33% of the value set by parameter 301, and the power is reduced	FFC8
Over Voltage Fault	Forklift voltage exceeds 43% of the value set by parameter 301, and the power shuts down	FFCA
Phase Voltage Too Low	Phase voltage is lower than the set value	3110
Phase Voltage Too High Fault	Phase voltage is higher than set value	3120
Phase Current Fault	Pump control/travel motor open circuit	3111
Main Contactor not Closing Fault	None (not caused by controller failure)	5442
Main Contactor does not close	None (not cause by controller failure)	5441
Main Contactor Sticking	None (not caused by controller failure)	5443
Main contactor Open	None (not caused by controller failure)	FFE6
Main Contactor Short Circuit	None (not caused by controller failure)	2250
Walking Direction Failure	Forward and backward command overlap error	FF50
Motor Stalled	The load is too large, or the encoder failed	FFD3
Motor Overspeed Fault	The motor feedback is greater than 20% of the maximum motor speed set by parameter 501	FFAF

Phase Current Overcurrent Fault	The current sensor sampling exceeds 1150A and the current sensor sampling exceeds 1000A and the current sensor sampling exceeds 3s	FFB4
MOS Board Over Temperature Failure	MOS board temperature is greater than 194°F. When MOS temperature is greater than 200°F, it will shut down	4210
Motor Over Temperature Fault	248°F<Motor Temperature<300°F	4110
Motor Over Temperature Fault 2	248°F<392°F	FFB2
Motor Over temperature Fault 3	Motor temperature > 300°F, or Motor temperature < -40°F	4311
Low Battery Fault	Battery Charge is less than 20%	FF42
Wrong Boot Sequence	Press the accelerator to start the engine or press the accelerator without engaging a gear.	FF4F

10. Forklift Safety Operating Procedures

 Warning: In order to ensure the safe operation of the stacker, in addition to being familiar with the working principle of the stacker and the relevant provisions of the manual, the operator should also operate according to the following procedures:

- 1) Only professionally trained and approved operators over 18 years of age are allowed to operate stackers.
- 2) The operator must be familiar with the instructions for the use of the stacker, wear a helmet, wear work shoes and work clothes and other protective equipment.
- 3) Before using the vehicle, the operator should check whether the safety devices are complete and intact, and whether all components are sensitive and effective. It is strictly prohibited to drive the stacker "under the influence".
- 4) The working surface should be a flat cement floor or similar ground. Check the ground conditions at the job site in advance. Clean the workplace, remove obstacles, sweep away gravel and sand, and wipe away oil and water stains.
- 5) Before operation, you should familiarize yourself with the graph on the load curve plate, which shows the relationship between the rated load and the load center distance. Overloading is strictly prohibited.
- 6) Before starting, sound the horn to make sure no one is around.
- 7) When stacking goods, do not allow the goods to deviate from the center of the fork. When the goods deviate from the center of the fork, turn or pass through uneven roads, they can easily fall. At the same time, the likelihood of a rollover increases.
- 8) Quick starts, quick stops, and sharp turns are not allowed.
- 9) It is prohibited to operate the stacker with the forks in a high position, and it is prohibited to lift or lower the fork with the fork forward. It must be completely closed before operating.
- 10) When the cargo load is too high and affects the line of sight, a guide should guide or let the cargo follow.
- 11) Due to the small wheels of the stacker truck, the stacker cannot run on the road, and only operates in specific stacking places.
- 12) It is forbidden to stand or walk under forks. No one is allowed to stand on the fork. Do not stretch your head, hands, feet, or body between the fork and the front leg. Once caught, your life will be in danger. Do not reach between the inner and outer frames.
- 13) Loading uphill should allow the cargo to run ahead. It is strictly prohibited to turn on the slope, otherwise there is a risk of overturning. Avoid working on slopes.
- 14) Do not charge the battery until the stacker cannot move, as this will shorten the battery life. When the indicator flashes red, please charge it immediately.
- 15) The stacker adopts electromagnetic braking mode, after the power is off, the brake will be dead, so the stacker cannot be towed (towed).
- 16) During operation, please follow the requirements of this operation and maintenance manual and the

stacker label. Check signs, labels, and replace ones that are damaged or have fallen off.

17) The workplace should be equipped with fire extinguishers. Users can also choose which fire extinguisher the vehicle is equipped with. Drivers and managers should be familiar with the location and use of fire extinguishers.

18) It is strictly forbidden to use water to clean the inside of the stacker truck, and it is strictly forbidden to leave the truck in the open air exposed to rain.

19) Before any disassembly or maintenance of the stacker, the battery must be unplugged.

20) Whenever a malfunction occurs, the stacker must be stopped, a "malfunction" sign hung on the vehicle, the key removed and reported to management. The stacker can be used only after the fault is eliminated. If a malfunction suddenly occurs when lifting goods, going uphill, or downhill, personnel should be organized immediately for emergency repairs.

21) Explosive gases will be produced inside the battery. It is absolutely forbidden to allow any flame to come close to the battery.

22) Before charging, check the cable connection and plug connection parts for visible damage.

23) The stacker charging space should be adequately ventilated.

24) The battery should be charged and stored when the vehicle is not in use. It is recommended to charge the battery once a week when not in use.

25) Flammable materials and working equipment that may spark shall not be placed within a distance of at least 6.5 feet around the stacker that needs to be charged.

26) Do not place metal objects on the battery, so as not to cause sparks or short circuit.

27) If the battery is used for more than 4 years, it needs to be replaced.

28) Try not to use it under conditions of overload, high humidity or steep slopes.

29) When charging externally, do not reverse the polarity of the battery, otherwise it may cause the battery to be scrapped.

30) After the battery is scrapped, please return it to the recycling station for unified disposal and do not discard it randomly.

11. Schematic Diagrams

11.1 Electrical System

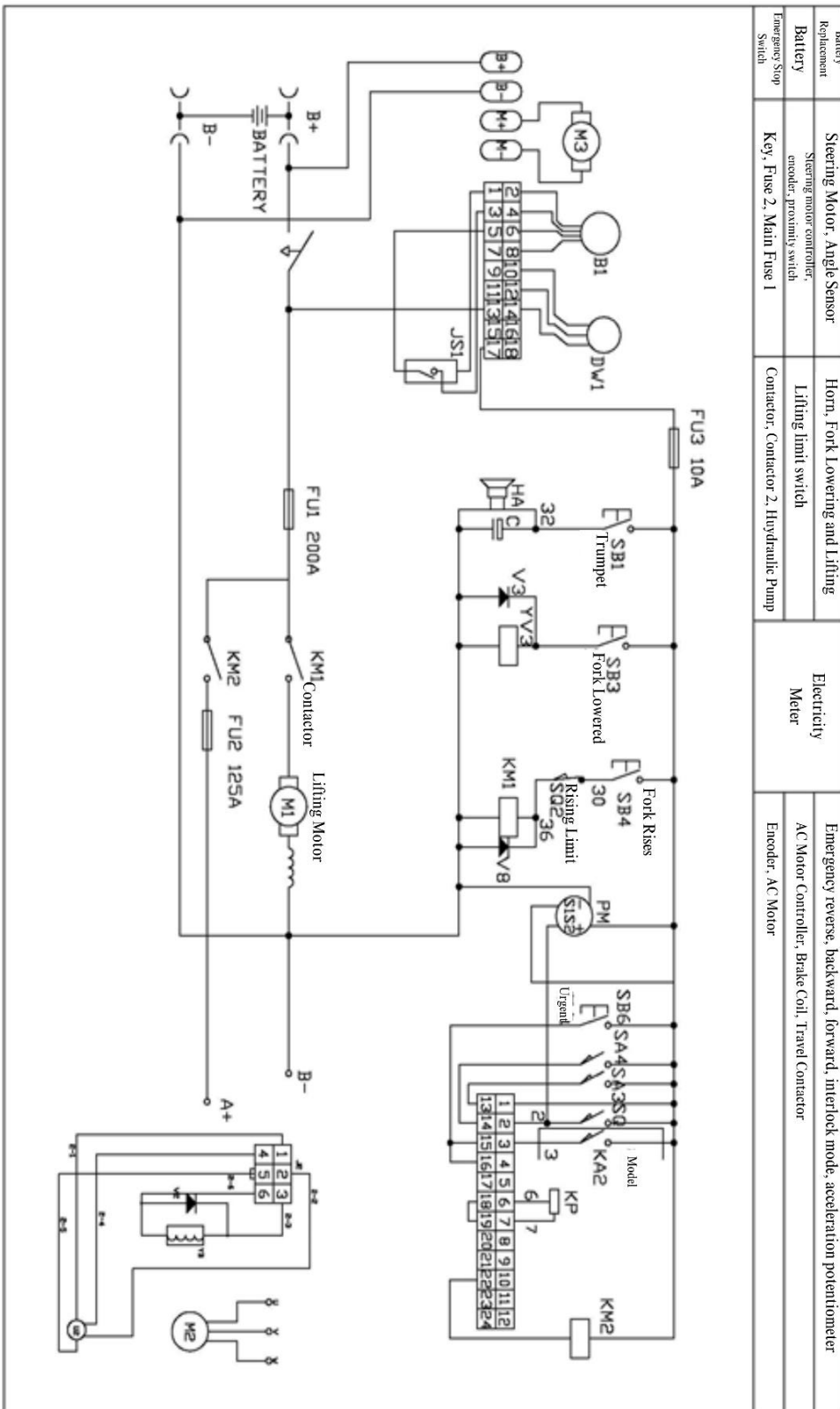

11.2 Hydraulic System

