

EKKO[®]

MATERIAL HANDLING EQUIPMENT

MOVING AHEAD

CATALOG



www.ekkolifts.com

Table of Contents

About US	3
FORKLIFTS	
Electric Forklift	4-20
REACH TRUCKS	
Electric Reach Trucks	21-26
COUNTERBALANCED STACKERS	
Electric Counterbalanced Stackers	27-31
STRADDLE STACKERS	
Electric Walkie Straddle Stackers	32-48
PALLET JACKS	
Electric and Manual Pallet Jacks	49-67
SCISSOR LIFT TABLE CARTS	
Single and Dual Scissor Table Carts	68-70
SCISSOR LIFT AERIAL PLATFORM	
Scissor Lift Aerial Platform	71-75
TOW TRACTORS	
Tow Tractor	76

About Us

Since 2008, EKKO Material Handling Equipment Manufacturing Inc. has become the go to manufacturer for the OEM and ODM channel. Due to our experience, innovative manufacturing capabilities, design, and our collaborations internationally, we have created enormous success with our partners in supplying them with nothing but quality forklifts, pallet trucks, walkie pallet trucks, walkie rider pallet trucks, stackers, walkie stackers, reach trucks, and many other material handling equipment.

With our strict research and development, quality control, and quality assurance departments, every product has and will continue to pass CE certification with international safety standards and ISO9001 Certification. In addition, our products have acquired self-managed import and export rights throughout North and South America, Europe, Australia and Asia.

OEM and ODM channels are welcomed. Furthermore, non-standard equipment is capable for production according to the customer's specifications and requirements. EKKO insists on the operating theory of "Services Create Enterprise Value", offering you top-ranking quality and professional after-service.

- **Superior Quality**
- **Reliability**
- **Versatility**
- **Advanced Engineering**
- **Competitive Pricing**
- **ISO Certified**
- **CE Certified**
- **Superior Support**
- **3 Years Warranty**



EK20R 4 Wheel Electric Forklift

Model		EK20R
Lift		Electric
Drive		Sit-Down
Load capacity	(lb.)	4500
Load center distance	(in)	24
Wheelbase	(in)	55.5
Lifting height	(in)	216
Free lifting height	(in)	73
Lowered mast height	(in)	93
Mast/Fork carriage tilt forward/backward	(°)	3/6
Side Shift		3-way valve
Overall length	(in)	134
Overall width	(in)	42
Fork size, Thick/Width/Length	(in)	1.6/4.7/45.3
Fork adjust width	(in)	9.4-35.6
Turning radius	(in)	84.6
Max gradient performance, laden/unladen	(%)	12/15
Lift speed, laden/unladen	(in/s)	7.5/9
Lowering speed, laden/unladen	(in/s)	9.5/10.2
Charger	(V/A)	48V/65A
Driving Motor	(V/W)	ZF AC 48V/7500
Lifting Motor	(W)	7700 Watt
Battery voltage	(V/Ah)	48V/420Ah (Side)
Service Weight	(lb.)	8000 lb.

The EKKO EK20R 4 Wheel Electric Forklift is designed for use for all of your material handling demands. It is ideal for loading and unloading trucks, loading docks, stock rooms, manufacturing floors and warehousing.

Made from high quality steel and components with durable quality drives to withstand any terrain, usage, impact and directional changes for the use of any application with confidence and assurance.

- Load Capacity 4500 lb.
- Raised Height 216" (18ft)
- Side Shift
- Free Lift 73"
- Adjustable Forks 9.4-35.6"
- Fork Length 45.3"
- Overhead Guard 86.5"
- Hydraulic Steering
- Curtis Instrument Controller
- ZF AC Drive Motor 7500 Watts
- 7700 Watts Lifting Motor
- Battery 48V/420Ah
- Solid Cushion Tires
- Ergonomic Handle and Controls
- Steel Construction
- Robotic Welding
- Charger 48V/65A
- 3 Year Limited Warranty

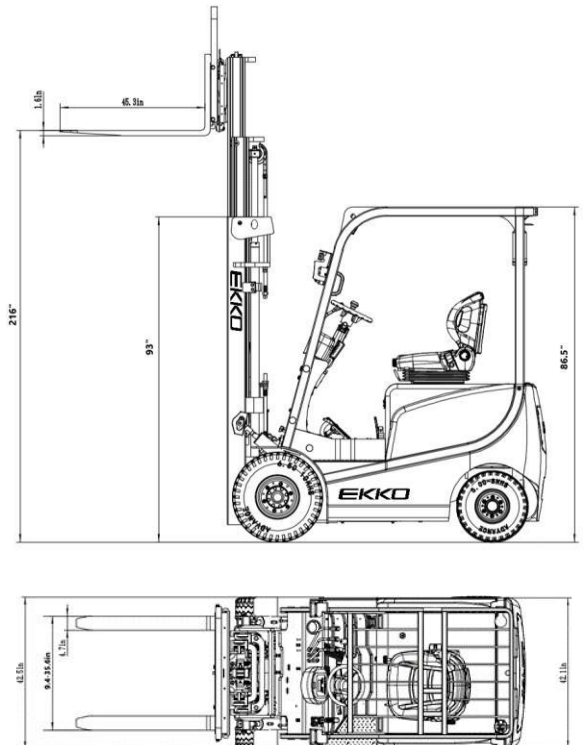

EK20RL 4 Wheel Electric Forklift

Model		EK20RL
Lift		Electric
Drive		Sit-Down
Load capacity	(lb.)	4500
Load center distance	(in)	24
Wheelbase	(in)	55.5
Lifting height	(in)	189
Free lifting height	(in)	65
Lowered mast height	(in)	84
Mast/Fork carriage tilt forward/backward	(°)	3/6
Side Shift		3-way valve
Overall length	(in)	134
Overall width	(in)	42
Fork size, Thick/Width/Length	(in)	1.6/4.7/45.3
Fork adjust width	(in)	9.4-35.6
Turning radius	(in)	84.6
Max gradient performance, laden/unladen	(%)	12/15
Lift speed, laden/unladen	(in/s)	7.5/9
Lowering speed, laden/unladen	(in/s)	9.5/10.2
Charger	(V/A)	48V/65A
Driving Motor	(V/W)	ZF AC 48V/7500W
Lifting Motor	(W)	7700
Battery voltage	(V/Ah)	48V/420Ah (Side)
Service Weight	(lb.)	7500 lb.

The EKKO EK20RL 4 Wheel Electric Forklift is designed for use for all of your material handling demands. It is ideal for loading and unloading trucks, loading docks, stock rooms, manufacturing floors and warehousing.

Made from high quality steel and components with durable quality drives to withstand any terrain, usage, impact and directional changes for the use of any application with confidence and assurance.

- Load Capacity 4500 lb.
- Raised Height 189" (15.75ft)
- Side Shift
- Free Lift 68"
- Adjustable Forks 9.4-35.6"
- Fork Length 45.3"
- Overhead Guard 86.5"
- Hydraulic Steering
- Curtis Instrument Controller
- ZF AC Drive Motor 7500 Watts
- 7700 Watts Lifting Motor
- Battery 48V/420Ah
- Solid Cushion Tires
- Ergonomic Handle and Controls
- Steel Construction
- Robotic Welding
- Charger 48V/65A
- 3 Year Limited Warranty

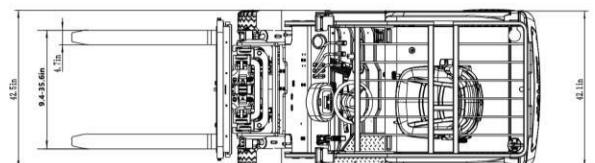
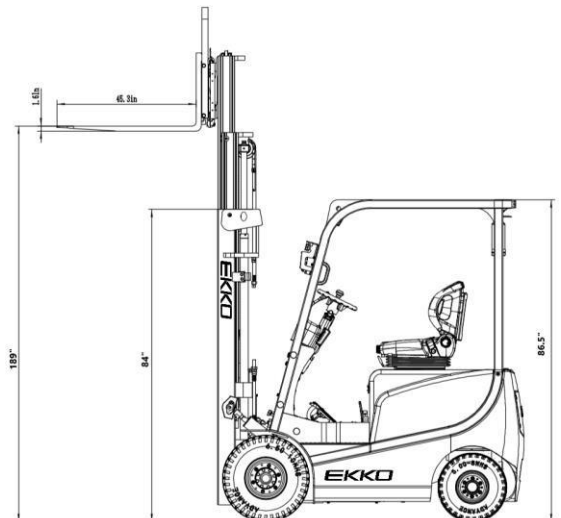

EK20-189Li 4 Wheel Lithium-iron Forklift

Model		EK20-189Li
Lift		Electric
Drive		Sit-Down
Load capacity	(lb.)	4500
Load center distance	(in)	19.68
Wheelbase	(in)	59.84
Lifting height	(in)	189
Free lifting height	(in)	43.4
Lowered mast height	(in)	83.94
Mast/Fork carriage tilt forward/backward	(°)	6/6
Side Shift		3-way valve
Overall length	(in)	132.28
Overall width	(in)	42.12
Fork size, Thick/Width/Length	(in)	1.57/4.72/42.12
Fork adjust width	(in)	8.7-29
Turning radius	(in)	86.02
Max gradient performance, laden/unladen	(%)	6/8
Lift speed, laden/unladen	(in/s)	9.45/12.6
Lowering speed, laden/unladen	(in/s)	8/6.8
Charger	(V/A)	48V/60A
Driving Motor	(K/W)	7.5
Lifting Motor	(K/W)	7.7
Battery voltage	(V/Ah)	48V/350Ah Li
Service Weight	(lb.)	8560 lb.

The EKKO EK20-189LI 4 Wheel Electric Forklift with lithium battery is designed for use for all of your material handling demands. It features fast charging abilities (fully charged after 2.5 hours). It is ideal for loading and unloading trucks, loading docks, stock rooms, manufacturing floors and warehousing.

Made from high quality steel and components with durable quality drives to withstand any terrain, usage, impact and directional changes for the use of any application with confidence and assurance.

- Load Capacity 4500 lb.
- Raised Height 189" (15.75ft)
- Side Shift
- Free Lift 43.4"
- Adjustable Forks 9.4-34.25"
- Fork Length 42"
- Hydraulic Steering
- Curtis Instrument Controller
- AC Drive Motor 7500 Watts
- 7700 Watts Lifting Motor
- Battery 48V/350Ah Lithium (Included)
- Solid Cushion Tires
- Ergonomic Handle and Controls
- Steel Construction
- Robotic Welding
- Charger 48V/60A 480V
- 3 Year Limited Warranty

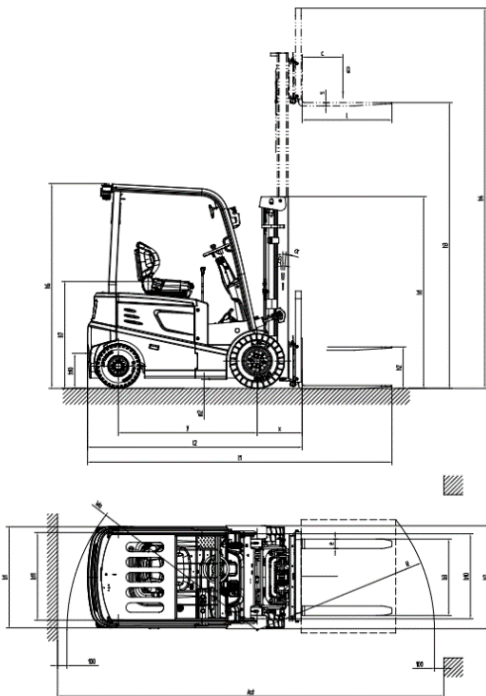

EK20-216Li 4 Wheel Lithium-iron Forklift

Model		EK20-216Li
Lift		Electric
Drive		Sit-Down
Load capacity	(lb.)	4500
Load center distance	(in)	19.68
Wheelbase	(in)	59.84
Lifting height	(in)	216
Free lifting height	(in)	52.55
Lowered mast height	(in)	93.11
Mast/Fork carriage tilt forward/backward	(°)	6/6
Side Shift		3-way valve
Overall length	(in)	132.28
Overall width	(in)	42.12
Fork size, Thick/Width/Length	(in)	1.57/4.72/42.12
Fork adjust width	(in)	8.7-29
Turning radius	(in)	86.02
Max gradient performance, laden/unladen	(%)	6/8
Lift speed, laden/unladen	(in/s)	9.45/12.6
Lowering speed, laden/unladen	(in/s)	8/6.8
Charger	(V/A)	48V/60A
Driving Motor	(K/W)	7.5
Lifting Motor	(K/W)	7.7
Battery voltage	(V/Ah)	48V/350Ah Li
Service Weight	(lb.)	8780 lb.

The EKKO EK20-216LI 4 Wheel Electric Forklift with lithium battery is designed for use for all of your material handling demands. It features fast charging abilities (fully charged after 2.5 hours). It is ideal for loading and unloading trucks, loading docks, stock rooms, manufacturing floors and warehousing.

Made from high quality steel and components with durable quality drives to withstand any terrain, usage, impact and directional changes for the use of any application with confidence and assurance.

- Load Capacity 4500 lb.
- Raised Height 216" (18ft)
- Side Shift
- Free Lift 52.55"
- Adjustable Forks 9.4-34.25"
- Fork Length 42"
- Hydraulic Steering
- Curtis Instrument Controller
- AC Drive Motor 7500 Watts
- 7700 Watts Lifting Motor
- Battery 48V/350Ah Lithium (Included)
- Solid Cushion Tires
- Ergonomic Handle and Controls
- Steel Construction
- Robotic Welding
- Charger 48V/60A 480V
- 3 Year Limited Warranty

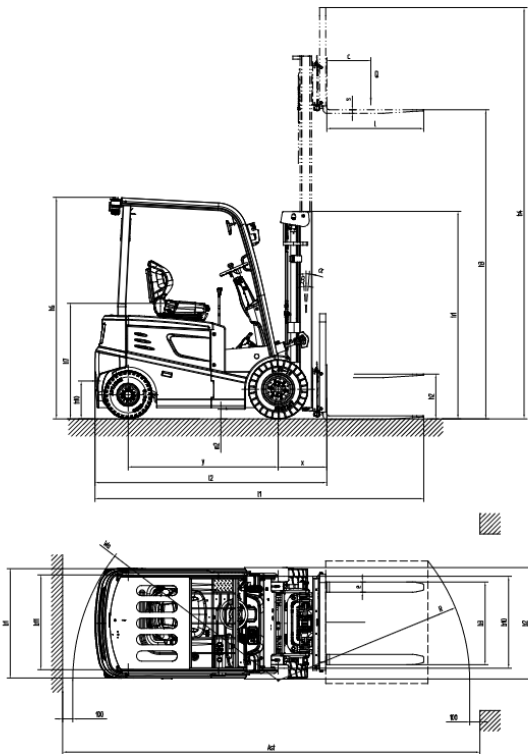

EK22-189Li 4 Wheel Lithium-iron Forklift

Model		EK22-189Li
Lift		Electric
Drive		Sit-Down
Load capacity	(lb.)	5000
Load center distance	(in)	19.68
Wheelbase	(in)	59.84
Lifting height	(in)	189
Free lifting height	(in)	43.4
Lowered mast height	(in)	83.94
Mast/Fork carriage tilt forward/backward	(°)	6/6
Side Shift		3-way valve
Overall length	(in)	132.28
Overall width	(in)	42.12
Fork size, Thick/Width/Length	(in)	1.57/4.72/42.12
Fork adjust width	(in)	8.7-29
Turning radius	(in)	86.02
Max gradient performance, laden/unladen	(%)	6/8
Lift speed, laden/unladen	(in/s)	9.45/12.6
Lowering speed, laden/unladen	(in/s)	8/6.8
Charger	(V/A)	48V/60A
Driving Motor	(K/W)	7.5
Lifting Motor	(K/W)	7.7
Battery voltage	(V/Ah)	48V/404Ah Li
Service Weight	(lb.)	9065 lb.

The EKKO EK22-189LI 4 Wheel Electric Forklift with lithium battery is designed for use for all of your material handling demands. It features fast charging abilities (fully charged after 2.5 hours). It is ideal for loading and unloading trucks, loading docks, stock rooms, manufacturing floors and warehousing.

Made from high quality steel and components with durable quality drives to withstand any terrain, usage, impact and directional changes for the use of any application with confidence and assurance.

- Load Capacity 5000 lb.
- Raised Height 189" (15.75ft)
- Side Shift
- Free Lift 43.4"
- Adjustable Forks 9.4-34.25"
- Fork Length 42"
- Hydraulic Steering
- Curtis Instrument Controller
- AC Drive Motor 7500 Watts
- 7700 Watts Lifting Motor
- Battery 48V/404Ah Lithium (Included)
- Solid Cushion Tires
- Ergonomic Handle and Controls
- Steel Construction
- Robotic Welding
- Charger 48V/60A 480V
- 3 Year Limited Warranty

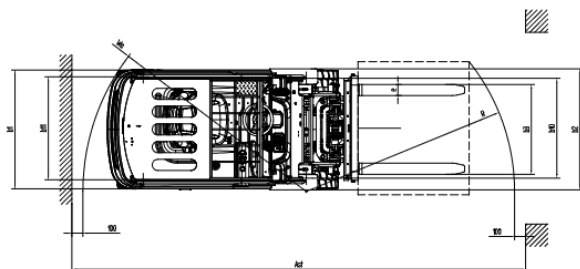
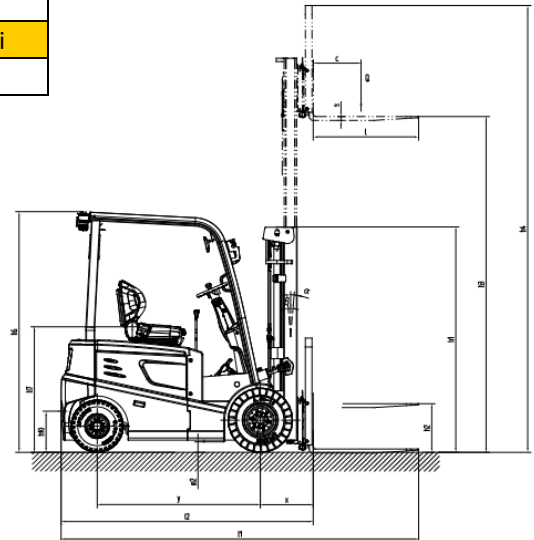

EK22-216Li 4 Wheel Lithium-iron Forklift

Model		EK22-216Li
Lift		Electric
Drive		Sit-Down
Load capacity	(lb.)	5000
Load center distance	(in)	19.68
Wheelbase	(in)	59.84
Lifting height	(in)	216
Free lifting height	(in)	52.55
Lowered mast height	(in)	93.11
Mast/Fork carriage tilt forward/backward	(°)	6/6
Side Shift		3-way valve
Overall length	(in)	132.28
Overall width	(in)	42.12
Fork size, Thick/Width/Length	(in)	1.57/4.72/42.12
Fork adjust width	(in)	8.7-29
Turning radius	(in)	86.02
Max gradient performance, laden/unladen	(%)	6/8
Lift speed, laden/unladen	(in/s)	9.45/12.6
Lowering speed, laden/unladen	(in/s)	8/6.8
Charger	(V/A)	48V/60A
Driving Motor	(K/W)	7.5
Lifting Motor	(K/W)	7.7
Battery voltage	(V/Ah)	48V/404Ah Li
Service Weight	(lb.)	9285 lb.

The EKKO EK22-216LI 4 Wheel Electric Forklift with lithium battery is designed for use for all of your material handling demands. It features fast charging abilities (fully charged after 2.5 hours). It is ideal for loading and unloading trucks, loading docks, stock rooms, manufacturing floors and warehousing.

Made from high quality steel and components with durable quality drives to withstand any terrain, usage, impact and directional changes for the use of any application with confidence and assurance.

- Load Capacity 5000 lb.
- Raised Height 216" (18ft)
- Side Shift
- Free Lift 52.55"
- Adjustable Forks 9.4-34.25"
- Fork Length 42"
- Hydraulic Steering
- Curtis Instrument Controller
- AC Drive Motor 7500 Watts
- 7700 Watts Lifting Motor
- Battery 48V/350Ah Lithium (Included)
- Solid Cushion Tires
- Ergonomic Handle and Controls
- Steel Construction
- Robotic Welding
- Charger 48V/60A 480V
- 3 Year Limited Warranty

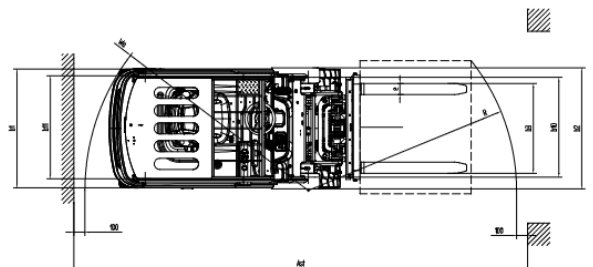
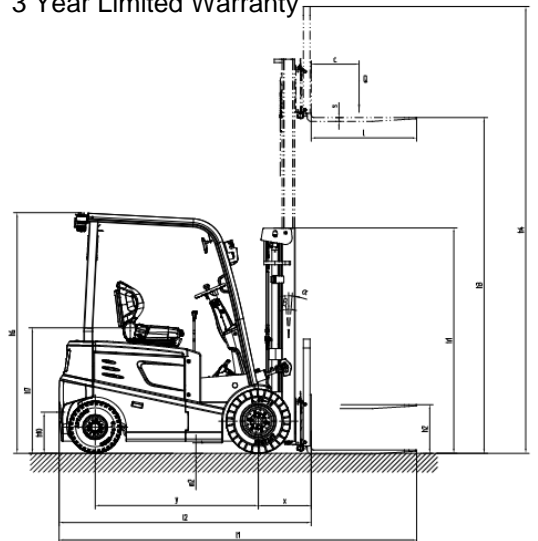

EK20G 4 Wheel Forklift

Model		EK20G
Lift		Electric
Drive		Sit-Down
Load capacity	(lb.)	4500
Load center distance	(in)	19.68
Wheelbase	(in)	59.84
Lifting height	(in)	216
Free lifting height	(in)	52.55
Lowered mast height	(in)	93.11
Mast/Fork carriage tilt forward/backward	(°)	6/6
Side Shift		3-way valve
Overall length	(in)	132.28
Overall width	(in)	42.12
Fork size, Thick/Width/Length	(in)	1.57/4.72/42.12
Fork adjust width	(in)	8.7-29
Turning radius	(in)	86.02
Max gradient performance, laden/unladen	(%)	6/8
Lift speed, laden/unladen	(in/s)	9.45/12.6
Lowering speed, laden/unladen	(in/s)	8/6.8
Charger	(V/A)	48V/65A
Driving Motor	(K/W)	7.5
Lifting Motor	(K/W)	7.7
Battery voltage	(V/Ah)	48V/400AH
Service Weight	(lb.)	8980 lb.

The EKKO EK20G 4 Wheel Electric Forklift is designed for use for all of your material handling demands. It is ideal for loading and unloading trucks, loading docks, stock rooms, manufacturing floors and warehousing.

Made from high quality steel and components with durable quality drives to withstand any terrain, usage, impact and directional changes for the use of any application with confidence and assurance.

- Load Capacity 4500 lb.
- Raised Height 216" (18ft)
- Side Shift
- Free Lift 52.55"
- Adjustable Forks 9.4-34.25"
- Fork Length 42"
- Hydraulic Steering
- Curtis Instrument Controller
- AC Drive Motor 7500 Watts
- 7700 Watts Lifting Motor
- Battery 48V/350Ah
- Solid Cushion Tires
- Ergonomic Handle and Controls
- Steel Construction
- Robotic Welding
- Charger 48V 400-510AH
- 3 Year Limited Warranty

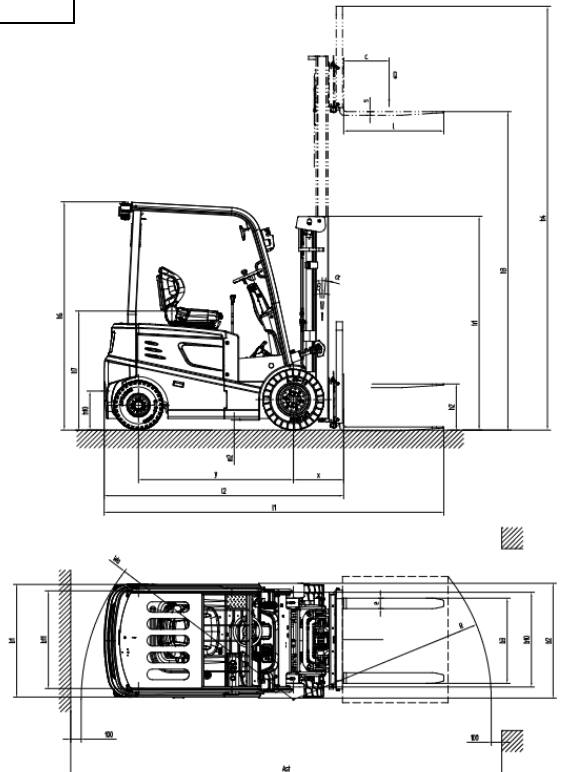

EK20GL 4 Wheel Forklift

Model		EK20GL
Lift		Electric
Drive		Sit-Down
Load capacity	(lb.)	4500
Load center distance	(in)	19.68
Wheelbase	(in)	59.84
Lifting height	(in)	189
Free lifting height	(in)	43.4
Lowered mast height	(in)	83.94
Mast/Fork carriage tilt forward/backward	(°)	6/6
Side Shift		3-way valve
Overall length	(in)	132.28
Overall width	(in)	42.12
Fork size, Thick/Width/Length	(in)	1.57/4.72/42.12
Fork adjust width	(in)	8.7-29
Turning radius	(in)	86.02
Max gradient performance, laden/unladen	(%)	6/8
Lift speed, laden/unladen	(in/s)	9.45/12.6
Lowering speed, laden/unladen	(in/s)	8/6.8
Charger	(V/A)	48V/65A
Driving Motor	(K/W)	7.5
Lifting Motor	(K/W)	7.7
Battery voltage	(V/Ah)	48V/400AH
Service Weight	(lb.)	8770 lb.

The EKKO EK20GL 4 Wheel Electric Forklift is designed for use for all of your material handling demands. It is ideal for loading and unloading trucks, loading docks, stock rooms, manufacturing floors and warehousing.

Made from high quality steel and components with durable quality drives to withstand any terrain, usage, impact and directional changes for the use of any application with confidence and assurance.

- Load Capacity 4500 lbs.
- Lift Height 189 in.
- **Side-Shift**
- Free Lift 43"
- Hydraulic Steering
- Length 132.28 in.
- Curtis Controller
- Tilt
- Fork Length 42"
- Mast Height 83.94"
- Batteries & Charger
- 3 Year Limited Warranty



EK22G 4 Wheel Forklift

Model		EK22G
Lift		Electric
Drive		Sit-Down
Load capacity	(lb.)	5000
Load center distance	(in)	19.68
Wheelbase	(in)	59.84
Lifting height	(in)	216
Free lifting height	(in)	52.55
Lowered mast height	(in)	93.11
Mast/Fork carriage tilt forward/backward	(°)	6/6
Side Shift		3-way valve
Overall length	(in)	132.28
Overall width	(in)	42.12
Fork size, Thick/Width/Length	(in)	1.57/4.72/42.12
Fork adjust width	(in)	8.7-29
Turning radius	(in)	86.02
Max gradient performance, laden/unladen	(%)	6/8
Lift speed, laden/unladen	(in/s)	9.45/12.6
Lowering speed, laden/unladen	(in/s)	8/6.8
Charger	(V/A)	48V 65AH
Driving Motor	(K/W)	7.5
Lifting Motor	(K/W)	7.7
Battery voltage	(V/Ah)	48V/510AH
Service Weight	(lb.)	9485 lb.

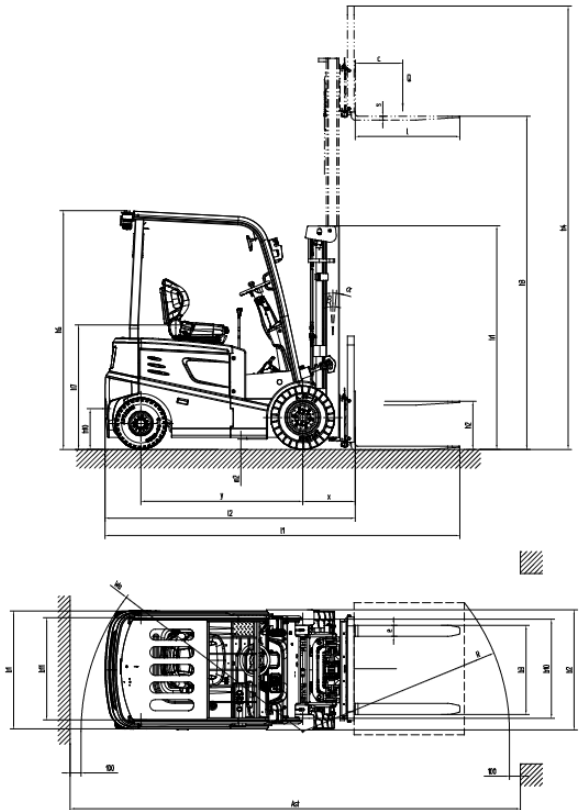

The EKKO EK22G 4 Wheel Electric Forklift is designed for use for all of your material handling demands. It is ideal for loading and unloading trucks, loading docks, stock rooms, manufacturing floors and warehousing.

Made from high quality steel and components with durable quality drives to withstand any terrain, usage, impact and directional changes for the use of any application with confidence and assurance.

- Load Capacity 5000 lb.
- Raised Height 216" (18ft)
- Side Shift
- Free Lift 52.55"
- Adjustable Forks 9.4-34.25"
- Fork Length 42"
- Hydraulic Steering
- Curtis Instrument Controller
- AC Drive Motor 7500 Watts
- 7700 Watts Lifting Motor
- Battery 48V/400-510AH
- Solid Cushion Tires
- Ergonomic Handle and Controls
- Steel Construction
- Robotic Welding
- Charger 48V/60A 480V
- 3 Year Limited Warranty



EK22GL 4 Wheel Forklift

Model		EK22GL
Lift		Electric
Drive		Sit-Down
Load capacity	(lb.)	5000
Load center distance	(in)	19.68
Wheelbase	(in)	59.84
Lifting height	(in)	189
Free lifting height	(in)	43.4
Lowered mast height	(in)	83.94
Mast/Fork carriage tilt forward/backward	(°)	6/6
Side Shift		3-way valve
Overall length	(in)	132.28
Overall width	(in)	42.12
Fork size, Thick/Width/Length	(in)	1.57/4.72/42.12
Fork adjust width	(in)	8.7-29
Turning radius	(in)	86.02
Max gradient performance, laden/unladen	(%)	6/8
Lift speed, laden/unladen	(in/s)	9.45/12.6
Lowering speed, laden/unladen	(in/s)	8/6.8
Charger	(V/A)	48V/65A
Driving Motor	(K/W)	7.5
Lifting Motor	(K/W)	7.7
Battery voltage	(V/Ah)	48V/510Ah
Service Weight	(lb.)	9265 lb.

The EKKO EK22GL 4 Wheel Electric Forklift is designed for use for all of your material handling demands. It is ideal for loading and unloading trucks, loading docks, stock rooms, manufacturing floors and warehousing.

Made from high quality steel and components with durable quality drives to withstand any terrain, usage, impact and directional changes for the use of any application with confidence and assurance.

- Load Capacity 5000 lb.
- Raised Height 189" (15.75ft)
- Side Shift
- Free Lift 43.4"
- Adjustable Forks 9.4-34.25"
- Fork Length 42"
- Hydraulic Steering
- Curtis Instrument Controller
- AC Drive Motor 7500 Watts
- 7700 Watts Lifting Motor
- Battery 48V/400-510AH
- Solid Cushion Tires
- Ergonomic Handle and Controls
- Steel Construction
- Robotic Welding
- Charger 48V/65A
- 3 Year Limited Warranty

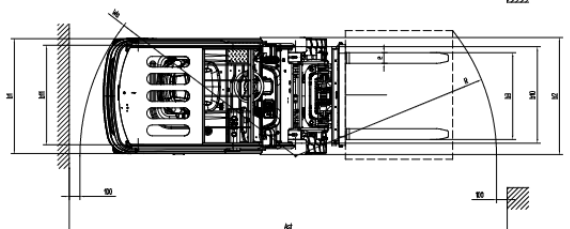
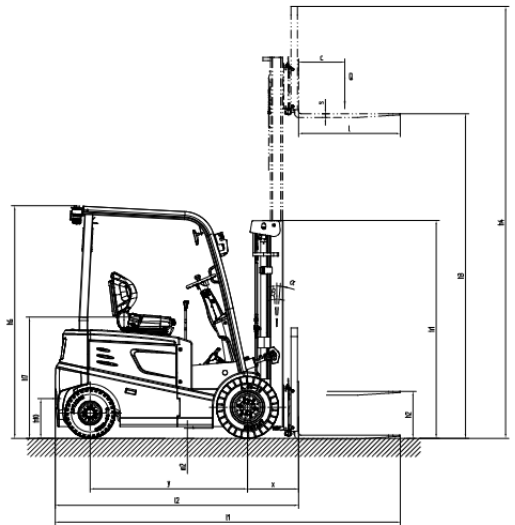

EK18RF Stand-up Rider Forklift

Model		EK18RF
Lift		Electric
Drive		Electric
Load capacity	(lb.)	4000
Load center distance	(in)	24
Wheelbase	(in)	48.8
Lifting height	(in)	216
Free lifting height	(in)	61.34
Lowered mast height	(in)	91.77
Mast/Fork carriage tilt forward/backward	(°)	3/5
Side Shifting Forks		3-way valve
Overall length	(in)	72.52
Overall width	(in)	42.52
Fork size, Thick/Width/Length	(in)	1.58/4.72/45
Fork adjust width	(in)	35
Turning radius	(in)	58.5
Max gradient performance, laden/unladen	(%)	6/10
Lift speed, laden/unladen	(in/s)	9.8/15
Lowering speed, laden/unladen	(in/s)	9.5/10.2
Charger	(V/A)	48V/65A
Driving Motor	(V/W)	ZF AC 48/6000
Lifting Motor	(V/W)	48/7700
Battery voltage	(V/Ah)	48V/420Ah (Side)
Service Weight	(lb.)	7940

The EKKO EK18RF Stand-up Forklift is designed for use for small aisles, limited spaces and budget. It is ideal for loading and unloading trucks, loading docks, stock rooms, manufacturing floors and warehousing.

Made from high quality steel and components with durable quality drives to withstand any terrain, usage, impact and directional changes for the use of any application with confidence and assurance.

- Load Capacity 4000 lb.
- Raised Height 216" (18ft)
- Side Shifting
- Free Lift 61.34"
- Adjustable Forks 8.7-35"
- Fork Length 45"
- Overhead Guard 90.08"
- EPS (Electric Power Steering)
- Curtis Instrument Controller
- 48V AC Drive Motor
- 48V Lift Motor
- Battery 48V/420Ah
- Solid Wheels
- Ergonomic Handle and Controls
- Steel Construction
- Robotic Welding
- Charger 48V/65A
- 3 Year Limited Warranty

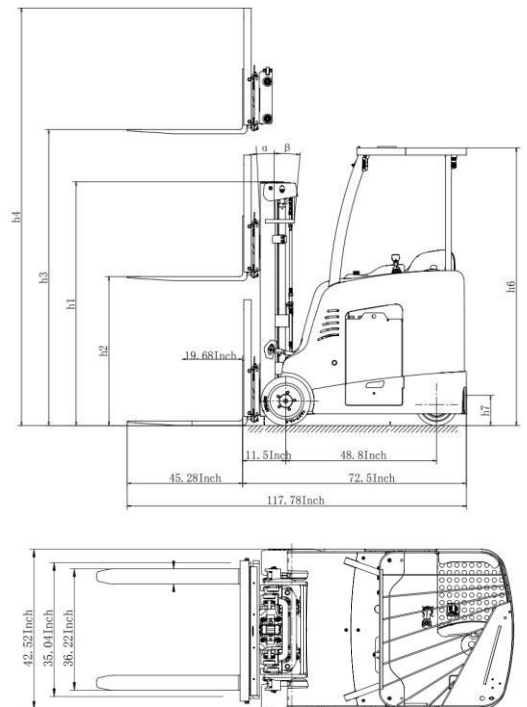

EK18RFL Stand-up Rider Forklift

Model		EK18RFL
Lift		Electric
Drive		Electric
Load capacity	(lb.)	4000
Load center distance	(in)	24
Wheelbase	(in)	48.8
Lifting height	(in)	189
Free lifting height	(in)	52.17
Lowered mast height	(in)	82.6
Mast/Fork carriage tilt forward/backward	(°)	3/5
Side Shifting Forks		3-way valve
Overall length	(in)	72.52
Overall width	(in)	42.52
Fork size, Thick/Width/Length	(in)	1.58/4.72/45
Fork adjust width	(in)	35
Turning radius	(in)	58.5
Max gradient performance, laden/unladen	(%)	6/10
Lift speed, laden/unladen	(in/s)	9.8/15
Lowering speed, laden/unladen	(in/s)	9.5/10.2
Charger	(V/A)	48V/65A
Driving Motor	(V/W)	ZF AC 48/6000
Lifting Motor	(V/W)	48/7700
Battery voltage	(V/Ah)	48V/420Ah (Side)
Service Weight	(lb.)	7870

The EKKO EK18RF Stand-up Forklift is designed for use for small aisles, limited spaces and budget. It is ideal for loading and unloading trucks, loading docks, stock rooms, manufacturing floors and warehousing.

Made from high quality steel and components with durable quality drives to withstand any terrain, usage, impact and directional changes for the use of any application with confidence and assurance.

- Load Capacity 4000 lb.
- Raised Height 189" (15.75ft)
- Side Shifting
- Free Lift 52.17"
- Adjustable Forks 8.7-35"
- Fork Length 45"
- Overhead Guard 90.08"
- EPS (Electric Power Steering)
- Curtis Instrument Controller
- 48V AC Drive Motor
- 48V Lift Motor
- Battery 48V/420Ah
- Solid Wheels
- Ergonomic Handle and Controls
- Steel Construction
- Robotic Welding
- Charger 48V/65A
- 3 Year Limited Warranty

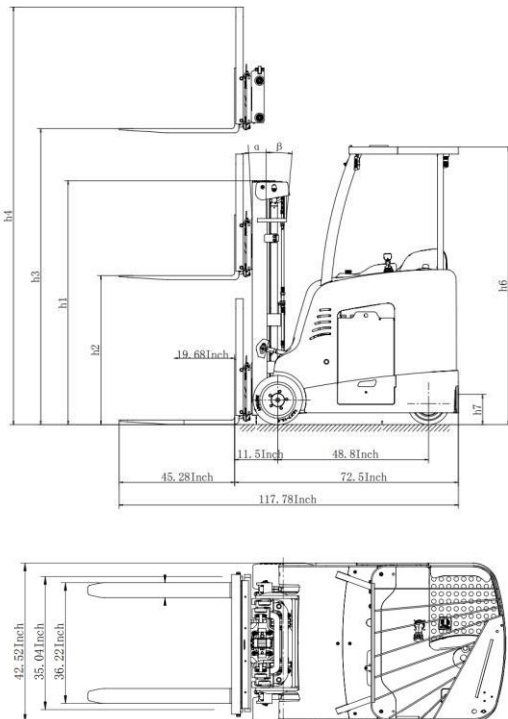

EK18AH 3 Wheel Electric Forklift

Model		EK18AH
Lift		Electric
Drive		Electric
Load capacity	(lb.)	4000
Load center distance	(in)	24
Wheelbase	(in)	54
Lifting height	(in)	216
Free lifting height	(in)	72
Lowered mast height	(in)	92
Mast/Fork carriage tilt forward/backward	(°)	2/5
Side Shifting Forks		3-way valve
Overall length	(in)	80
Overall width	(in)	42.5
Fork size, Thick/Width/Length	(in)	1.58/4.72/45.3
Fork adjust width	(in)	8.7-29
Turning radius	(in)	64.17
Max gradient performance, laden/unladen	(%)	10/15
Lift speed, laden/unladen	(in/s)	9.84/15.75
Lowering speed, laden/unladen	(in/s)	9.45/10.16
Charger	(V/A)	48V/65A
Driving Motor	(V/W)	AC 48V/7500W
Lifting Motor	(V/W)	48V/7000W
Battery voltage	(V/Ah)	48V/425Ah (Side)
Service Weight	(lb.)	8100

The EKKO EK18AH 3 Wheel Electric Forklift is designed for use for small aisles, limited spaces and budget. It is ideal for loading and unloading trucks, loading docks, stock rooms, manufacturing floors and warehousing.

Made from high quality steel and components with durable quality drives to withstand any terrain, usage, impact and directional changes for the use of any application with confidence and assurance.

- Load Capacity 4000 lb.
- Raised Height 216" (18'ft)
- Side Shifting
- Free Lift 72"
- Adjustable Forks 8.7-29"
- Fork Length 45.3"
- Overhead Guard 82.68"
- EPS (Electric Power Steering)
- Curtis Instrument Controller
- 48V German AC Drive Motor
- 48V Lift Motor
- Battery 48V/425Ah
- Solid Wheels
- Ergonomic Handle and Controls
- Steel Construction
- Robotic Welding
- Charger 48V/65A
- 3 Year Limited Warranty

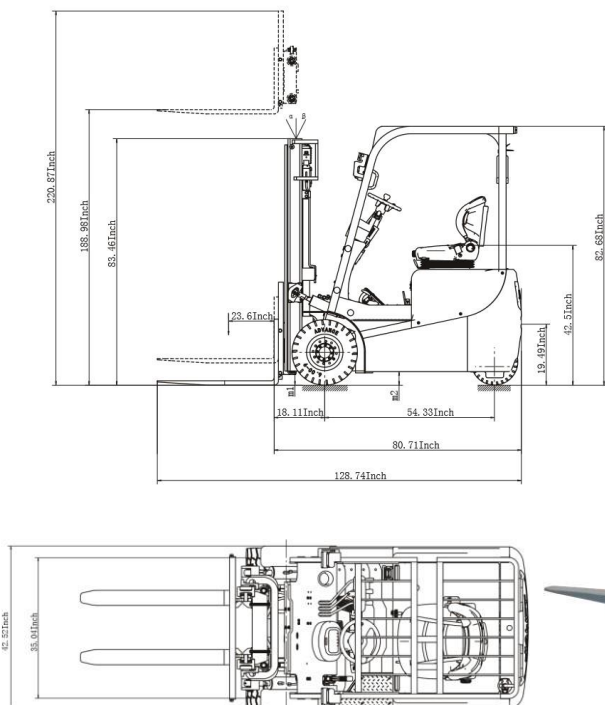

EK18A 3 Wheel Electric Forklift

Model		EK18A
Lift		Electric
Drive		Electric
Load capacity	(lb.)	4000
Load center distance	(in)	24
Wheelbase	(in)	54
Lifting height	(in)	189
Free lifting height	(in)	63.78
Lowered mast height	(in)	83.46
Mast/Fork carriage tilt forward/backward	(°)	2/5
Side Shifting Forks		3-way valve
Overall length	(in)	80
Overall width	(in)	42.5
Fork size, Thick/Width/Length	(in)	1.58/4.72/45.3
Fork adjust width	(in)	8.7-29
Turning radius	(in)	64.17
Max gradient performance, laden/unladen	(%)	10/15
Lift speed, laden/unladen	(in/s)	9.84/15.75
Lowering speed, laden/unladen	(in/s)	9.45/10.16
Charger	(V/A)	48V/65A
Driving Motor	(V/W)	AC 48V/7500W
Lifting Motor	(V/W)	48V/7000W
Battery voltage	(V/Ah)	48V/425Ah (Side)
Service Weight	(lb.)	7550

The EKKO EK18A 3 Wheel Electric Forklift is designed for use for small aisles, limited spaces and budget. It is ideal for loading and unloading trucks, loading docks, stock rooms, manufacturing floors and warehousing.

Made from high quality steel and components with durable quality drives to withstand any terrain, usage, impact and directional changes for the use of any application with confidence and assurance.

- Load Capacity 4000 lb.
- Raised Height 189" (15.75ft)
- Side Shifting
- Free Lift 63.78"
- Adjustable Forks 8.7-29"
- Fork Length 45.3"
- Overhead Guard 82.68"
- EPS (Electric Power Steering)
- Curtis Instrument Controller
- 48V German AC Drive Motor
- 48V Lift Motor
- Battery 48V/425Ah
- Solid Wheels
- Ergonomic Handle and Controls
- Steel Construction
- Robotic Welding
- Charger 48V/65A
- 3 Year Limited Warranty

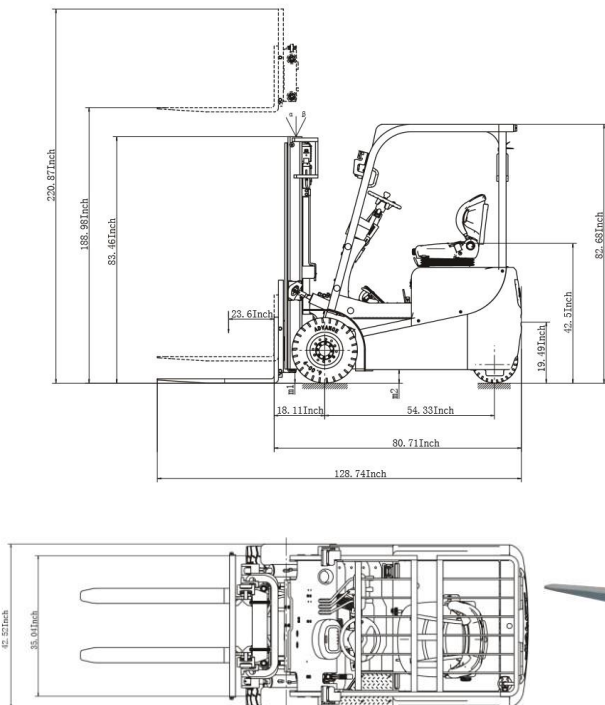

EK15A 3 Wheel Electric Forklift

Model		EK15A
Lift		Electric
Drive		Electric
Load capacity	(lb.)	3300
Load center distance	(in)	24
Wheel base	(in)	43
Lifting height	(in)	177
Free lifting height	(in)	59
Lowered mast height	(in)	79.6
Mast/Fork carriage tilt forward/backward	(°)	2/5
Side Shifting Forks		3-way valve
Overall length	(in)	106.6
Overall width	(in)	36
Fork size, Thick/Width/Length	(in)	1.4/4/45.3
Fork adjust width	(in)	8.7-29
Turning radius	(in)	53
Max gradient performance, laden/unladen	(%)	6/8
Lift speed, laden/unladen	(in/s)	4/5.5
Lowering speed, laden/unladen	(in/s)	5.3/4.7
Charger	(V/A)	24V/50A
Driving Motor	(V/W)	AC 24V/2000W
Lifting Motor	(V/W)	24V/2500W
Battery voltage	(V/Ah)	24V/400Ah (Side)
Service Weight	(lb.)	5665

The EKKO EK15A 3 Wheel Electric Forklift is designed for use for small aisles, limited spaces and budget. It is ideal for loading and unloading trucks, loading docks, stock rooms, manufacturing floors and warehousing.

Made from high quality steel and components with durable quality drives to withstand any terrain, usage, impact and directional changes for the use of any application with confidence and assurance.

- Load Capacity 3300 lb.
- Raised Height 177" (14.75ft)
- Side Shifting
- Free Lift 59"
- Adjustable Forks 8.7-29"
- Fork Length 45.3"
- Overhead Guard 77"
- EPS (Electric Power Steering)
- Curtis Instrument Controller
- 24V AC Drive Motor
- 24V Lift Motor
- Battery 24V/400Ah
- Solid Wheels
- Ergonomic Handle and Controls
- Steel Construction
- Robotic Welding
- Charger 24V/50Ah
- 3 Year Limited Warranty

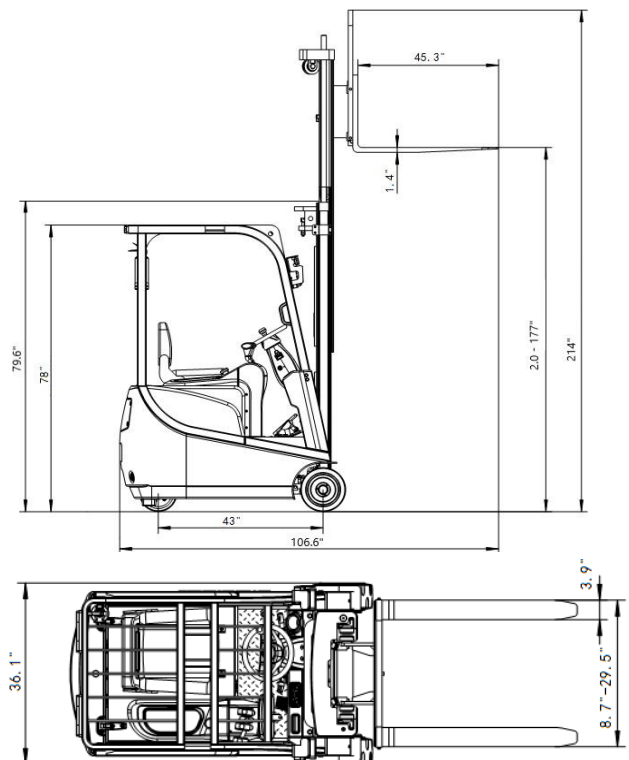

EK15A-189Li 3 Wheel Lithium-Iron Forklift

Model		EK15A-189Li
Lift		Electric
Drive		Electric
Load capacity	(lb.)	3300
Load center distance	(in)	24
Wheel base	(in)	42.91
Lifting height	(in)	189
Free lifting height	(in)	62.56
Lowered mast height	(in)	83.54
Mast/Fork carriage tilt forward/backward	(°)	2/5
Side Shifting Forks		3-way valve
Overall length	(in)	111.1
Overall width	(in)	36.1
Fork size, Thick/Width/Length	(in)	1.78/3.94/45.3
Fork adjust width	(in)	8.7-29
Turning radius	(in)	53.07
Max gradient performance, laden/unladen	(%)	6/10
Lift speed, laden/unladen	(in/s)	5.3/8.4
Lowering speed, laden/unladen	(in/s)	9.3/8.85
Charger		110 Plug in
Driving Motor	(V/W)	AC 24V/2000W
Lifting Motor	(V/W)	24V/2500W
Battery voltage	(V/Ah)	24V/350Ah Li
Service Weight	(lb.)	5560

The EKKO EK15A-189LI 3 Wheel Electric Forklift with lithium battery is designed for use for small aisles, limited spaces and budget. It is ideal for loading and unloading trucks, loading docks, stock rooms, manufacturing floors and warehousing.

Made from high quality steel and components with durable quality drives to withstand any terrain, usage, impact and directional changes for the use of any application with confidence and assurance. (Recommended for Indoor use on flat surfaces)

- Load Capacity 3300 lbs.
- Raised Height 189" (15.75ft)
- Free Lift 62.56"
- Side Shifting
- Adjustable Forks 8.66-33.74"
- Fork Length 45.3"
- Curtis Controller
- Tilt 2/5 Degree
- 24V AC Drive Motor
- 24V Lift Motor
- Cushion Wheels
- Ergonomic Handle and Controls
- EPS (Electronic Power Steering)
- Steel Construction
- Robotic Welding
- Charger Included
- Batteries Included
- 3 Years Limited Warranty

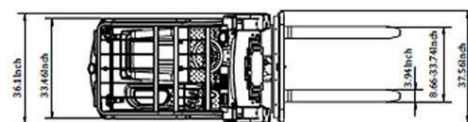
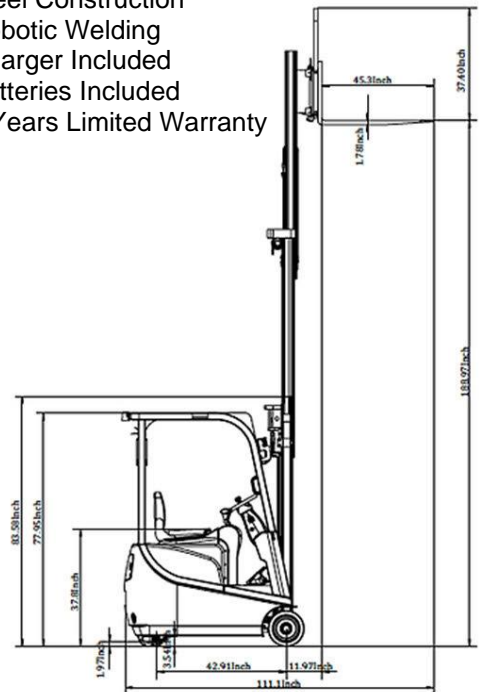

EK13A 3 Wheel Electric Forklift

Model		EK13A
Lift		Electric
Drive		Electric
Load capacity	(lb.)	3300
Load center distance	(in)	24
Wheelbase	(in)	43
Lifting height	(in)	138
Free lifting height	(in)	4
Lowered mast height	(in)	88.4
Mast/Fork carriage tilt forward/backward	(°)	2/5
Side Shifting Forks		3-way valve
Overall length	(in)	105
Overall width	(in)	36
Fork size, Thick/Width/Length	(in)	1.4/4/45.3
Fork adjust width	(in)	8.7-29
Turning radius	(in)	53
Max gradient performance, laden/unladen	(%)	6/8
Lift speed, laden/unladen	(in/s)	4/5.5
Lowering speed, laden/unladen	(in/s)	5.3/4.7
Charger	(V/A)	24V/50A
Driving Motor	(V/W)	AC 24V/2000W
Lifting Motor	(V/W)	24V/2500W
Battery voltage	(V/Ah)	24V/350Ah (Side)
Service Weight	(lb.)	5200

The EKKO EK13A 3 Wheel Electric Forklift is designed for use for small aisles, limited spaces and budget. It is ideal for loading and unloading trucks, loading docks, stock rooms, manufacturing floors and warehousing.

Made from high quality steel and components with durable quality drives to withstand any terrain, usage, impact and directional changes for the use of any application with confidence and assurance.

- Load Capacity 3300 lb.
- Raised Height 138" (11.5ft)
- Side Shifting
- Adjustable Forks 8.7-29"
- Fork Length 45.3"
- Overhead Guard 77"
- EPS (Electric Power Steering)
- Curtis Instrument Controller
- 24V AC Drive Motor
- 24V Lift Motor
- Battery 24V/350Ah
- Solid Wheels
- Ergonomic Handle and Controls
- Steel Construction
- Robotic Welding

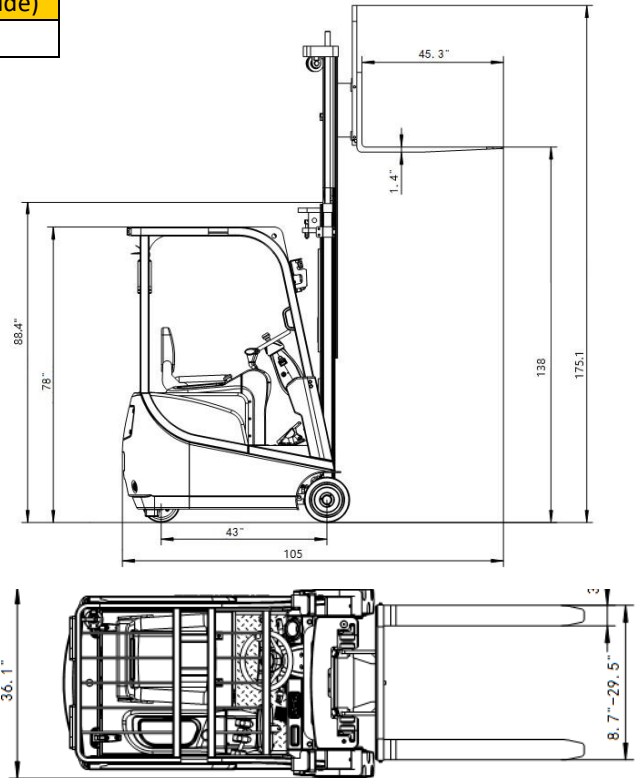

EK18RR Stand-up Rider Reach Truck



Model		EK18RR
Lift		Electric
Drive		Electric
Load capacity	(lb.)	4000
Load center distance	(in)	24
Lifting height	(in)	275
Side Shifting Forks		3 Way Valve
Free Lift	(in)	79.92
Lowered mast height	(in)	123.27
Overall length/Extended	(in)	102.28
Overall width	(in)	54.72
Fork size, Thick/Width/Length	(in)	1.58/4.72/45
Fork adjust width	(in)	35.04
Reach Distance	(in)	22.44
Turning radius	(in)	75
Charger	(V/A)	48V/65A
Driving Motor	(V/W)	48V/6000
EPS Steering Motor	(V/W)	Yes
Lifting Motor	(V/W)	48V/11000
Battery voltage	(V/Ah)	48V/420Ah
Service Weight	(lb.)	9330

The EK18RR Stand-Up Reach Truck is ideal and designed for narrow aisle with the combination of the versatility of a forklift, reach truck and a walkie stacker. It is ideal for loading and unloading trucks, loading docks, stock rooms, manufacturing floors and warehousing.

Made from high quality steel and components with durable quality drives to withstand any terrain, usage, impact and directional changes for the use of any application with confidence and assurance.

- Load Capacity 4000 lb.
- Side Shifting
- Raised Height 275" (14.75ft)
- Reach Distance of 19.7"
- Free Lift 63"
- Tilt 3/5 Degree
- Adjustable Forks 7.9-33"
- Fork Length 45.3"
- Curtis Instrument Controllers
- EPS (Electronic Power Steering)
- 48V German AC Drive Motor
- 48V Lift Motor
- Battery 48V/420Ah
- Polyurethane Wheels
- Ergonomic Handle and Controls
- Steel Construction
- Robotic Welding
- Charger 48V/65A
- 3 Year Limited Warranty

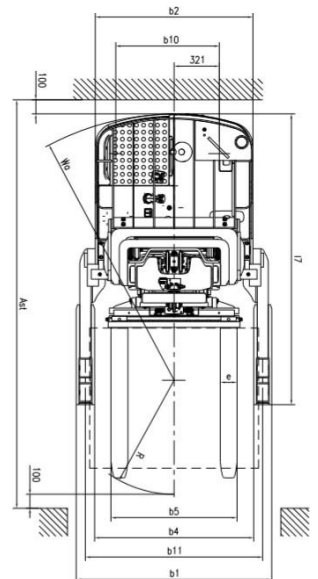
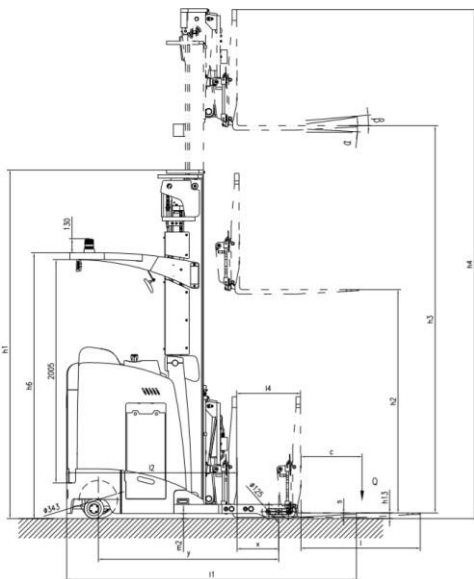

EK18RRL Stand-up Rider Reach Truck

Model		EK18RRL
Lift		Electric
Drive		Electric
Load capacity	(lb.)	4000
Load center distance	(in)	24
Lifting height	(in)	196
Side Shifting Forks		3 Way Valve
Free Lift	(in)	53.15
Lowered mast height	(in)	96.42
Overall length/Extended	(in)	102.28
Overall width	(in)	54.72
Fork size, Thick/Width/Length	(in)	1.58/4.72/45
Fork adjust width	(in)	35.04
Reach Distance	(in)	22.44
Turning radius	(in)	75
Charger	(V/A)	48V/65A
Driving Motor	(V/W)	48V/6000
EPS Steering Motor	(V/W)	Yes
Lifting Motor	(V/W)	48V/11000
Battery voltage	(V/Ah)	48V/420Ah
Service Weight	(lb.)	9000



The EKKO EK18RRL Stand-Up Reach Truck is ideal and designed for narrow aisle with the combination of the versatility of a forklift, reach truck and a walkie stacker. It is ideal for loading and unloading trucks, loading docks, stock rooms, manufacturing floors and warehousing.

Made from high quality steel and components with durable quality drives to withstand any terrain, usage, impact and directional changes for the use of any application with confidence and assurance.

- Load Capacity 4000 lb.
- Side Shifting
- Raised Height 275" (14.75ft)
- Reach Distance of 19.7"
- Free Lift 63"
- Tilt 3/5 Degree
- Adjustable Forks 7.9-33"
- Fork Length 45.3"
- Curtis Instrument Controllers
- EPS (Electronic Power Steering)
- 48V German AC Drive Motor
- 48V Lift Motor
- Battery 48V/420Ah
- Polyurethane Wheels
- Ergonomic Handle and Controls
- Steel Construction
- Robotic Welding
- Charger 48V/65A
- 3 Year Limited Warranty

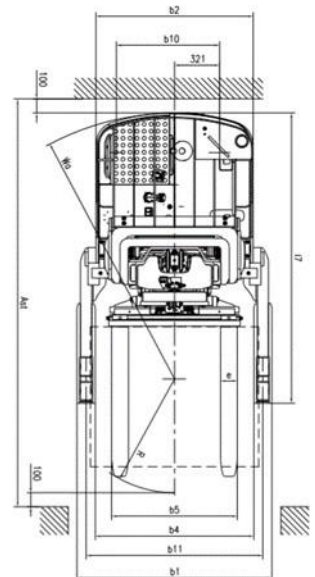
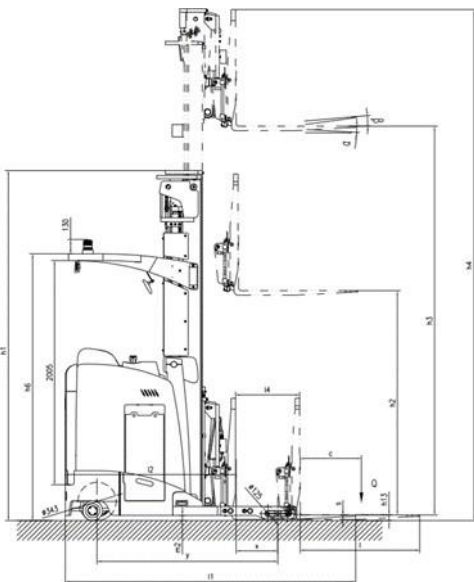

ER15 Walkie Reach Truck



Model		ER15
Lift		Electric
Drive		Electric
Load capacity	(lb.)	3300
Load center distance	(in)	24
Lifting height	(in)	177
Side Shifting Forks		3 Way Valve
Free Lift	(in)	63
Lowered mast height	(in)	87.4
Overall length/Extended	(in)	94/113.8
Overall width	(in)	43.8
Fork size, Thick/Width/Length	(in)	1.38/3.9/45.3
Fork adjust width	(in)	7.9-33
Reach Distance	(in)	19.7
Turning radius	(in)	64
Charger	(V/A)	24V/40A
Driving Motor	(V/W)	AC 24V/3kw
EPS Steering Motor	(V/W)	24/200W
Lifting Motor	(V/W)	24V/3000W
Battery voltage	(V/Ah)	24V/350Ah
Service Weight	(lb.)	5500

The EKKO ER15 Walkie Reach Truck is designed with the combination of the versatility of a forklift, reach truck and a walkie stacker. It is ideal for loading and unloading trucks, loading docks, stock rooms, manufacturing floors and warehousing.

Made from high quality steel and components with durable quality drives to withstand any terrain, usage, impact and directional changes for the use of any application with confidence and assurance.

- Load Capacity 3300 lb.
- Side Shifting
- Raised Height 177" (14.75ft)
- Reach Distance of 19.7"
- Free Lift 63"
- Tilt 3/5 Degree
- Adjustable Forks 7.9-33"
- Fork Length 45.3"
- Curtis Instrument Controllers
- EPS (Electronic Power Steering)
- 24V AC Drive Motor
- 24V Lift Motor
- Battery 24V/350Ah
- Polyurethane Wheels
- Ergonomic Handle and Controls
- Steel Construction
- Robotic Welding
- Charger 24V/40A
- 3 Year Limited Warranty

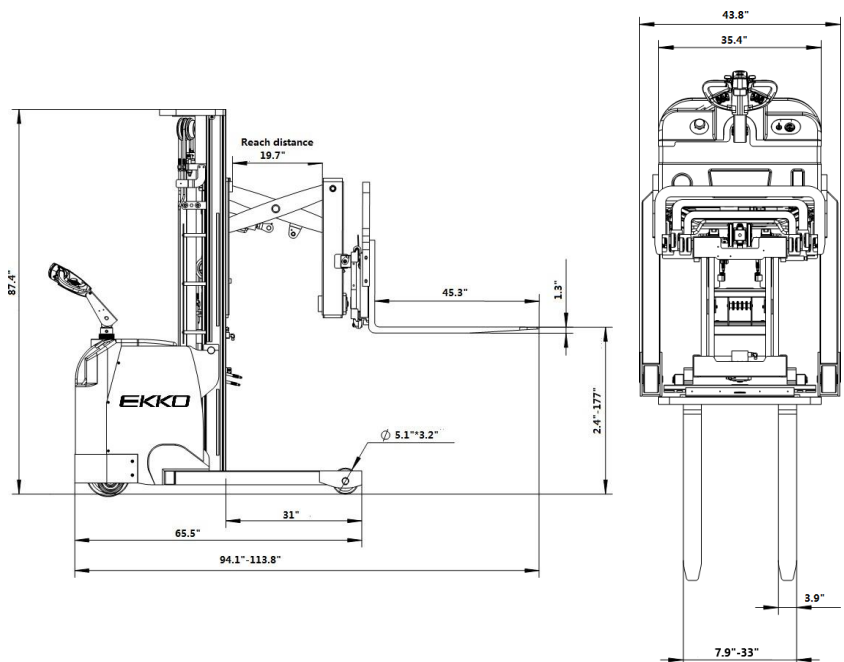

ER15L Walkie Reach Truck



Model		ER15L
Lift		Electric
Drive		Electric
Load capacity	(lb.)	3300
Load center distance	(in)	24
Lifting height	(in)	138
Side Shifting Forks		3 Way Valve
Free Lift	(in)	N/A
Lowered mast height	(in)	90.5
Overall length/Extended	(in)	94/113.8
Overall width	(in)	43.8
Fork size, Thick/Width/Length	(in)	1.38/3.9/45.3
Fork adjust width	(in)	7.9-33
Reach Distance	(in)	19.7
Turning radius	(in)	64
Charger	(V/A)	24V/50A
Driving Motor	(V/W)	AC 24V/3kw
EPS Steering Motor	(V/W)	24/200W
Lifting Motor	(V/W)	24V/3000W
Battery voltage	(V/Ah)	24V/350Ah
Service Weight	(lb.)	4800

The EKKO ER15L Walkie Reach Truck is designed with the combination of the versatility of a forklift, reach truck and a walkie stacker. It is ideal for loading and unloading trucks, loading docks, stock rooms, manufacturing floors and warehousing.

Made from high quality steel and components with durable quality drives to withstand any terrain, usage, impact and directional changes for the use of any application with confidence and assurance.

- Load Capacity 3300 lb.
- Side Shifting
- Raised Height 138" (11.50ft)
- Reach Distance of 19.7"
- Tilt 3/5 Degree
- Adjustable Forks 7.9-33"
- Fork Length 45.3"
- Curtis Instrument Controllers
- EPS (Electronic Power Steering)
- 24V AC Drive Motor
- 24V Lift Motor
- Battery 24V/350Ah
- Polyurethane Wheels
- Ergonomic Handle and Controls
- Steel Construction
- Robotic Welding
- Charger 24V/40A
- 3 Year Limited Warranty

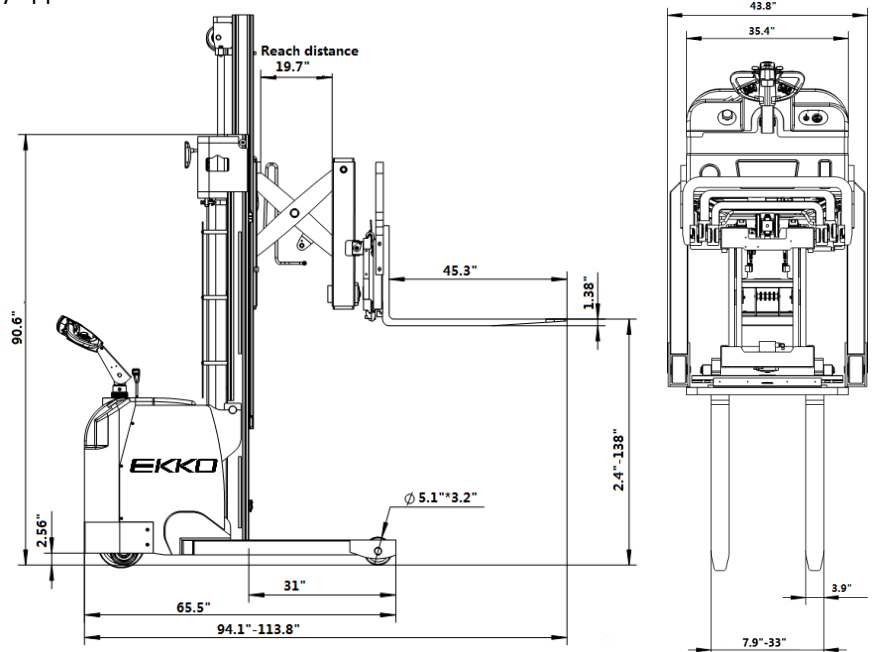

EH15TH Moving Mast Walkie Reach Truck



Model		EH15TH
Lift		Electric
Drive		Electric
Load capacity	(lb.)	3300
Load center distance	(in)	24
Lifting height	(in)	216
Free Lift	(in)	68"
Lowered mast height	(in)	97.3
Overall length	(in)	111.6
Overall width	(in)	41
Fork size, Thick/Width/Length	(in)	1.4/4/45.2
Fork adjust width	(in)	8.7-28
Reach Distance	(in)	19.7
Turning radius	(in)	67
Charger	(V/A)	24V/50A
Driving Motor	(V/W)	AC 24V/2.5kw
EPS Steering Motor	(V/W)	24/200W
Lifting Motor	(V/W)	24V/3000W
Battery voltage	(V/Ah)	24V/400Ah
Service Weight	(lb.)	4915

The EKKO EH15TH Moving Mast Walkie Reach Truck is designed with the combination of the versatility of a forklift, reach truck and a walkie stacker. It is ideal for loading and unloading trucks, loading docks, stock rooms, manufacturing floors and warehousing.

Made from high quality steel and components with durable quality drives to withstand any terrain, usage, impact and directional changes for the use of any application with confidence and assurance.

- Load Capacity 3300 lb.
- Raised Height 216" (18ft)
- Reach Distance of 19.7"
- Free Lift 68"
- Adjustable Forks 8.7-29.7"
- Fork Length 45.2"
- Curtis Instrument Controllers
- EPS (Electronic Power Steering)
- 24V AC Drive Motor
- 24V Lift Motor
- Battery 24V/400Ah
- Polyurethane Wheels
- Ergonomic Handle and Controls
- Steel Construction
- Robotic Welding
- Charger
- 3 Year Limited Warranty

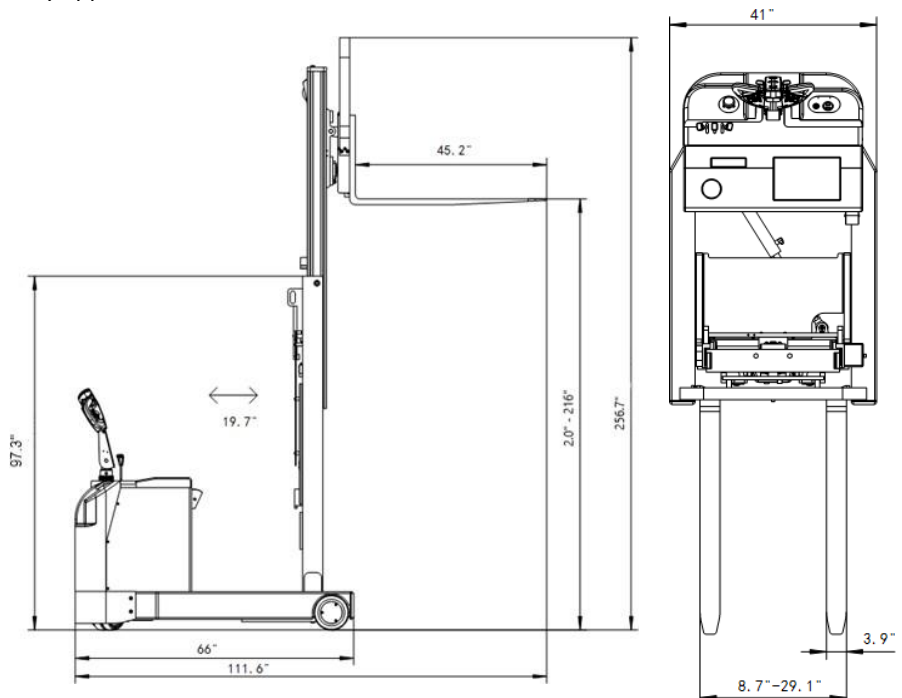

EH15T Moving Mast Walkie Reach Truck



Model		EH15T
Lift		Electric
Drive		Electric
Load capacity	(lb.)	3300
Load center distance	(in)	24
Lifting height	(in)	138
Lowered mast height	(in)	93.3
Overall length	(in)	111.6
Overall width	(in)	41
Fork size, Thick/Width/Length	(in)	1.4/4/45.2
Fork adjust width	(in)	8.7-28
Reach Distance	(in)	19.7
Turning radius	(in)	67
Charger	(in)	24V/40A
Driving Motor	(V/A)	AC 24V/2500W
Steering Motor	(V/W)	24V/200W
Lifting Motor	(V/W)	24V/3000W
Battery voltage	(V/Ah)	24V/270Ah
Service Weight	(lb.)	4200

The EKKO EH15T Moving Mast Walkie Reach Truck is designed with the combination of the versatility of a forklift, reach truck and a walkie stacker. It is ideal for loading and unloading trucks, loading docks, stock rooms, manufacturing floors and warehousing.

Made from high quality steel and components with durable quality drives to withstand any terrain, usage, impact and directional changes for the use of any application with confidence and assurance.

- Load Capacity 3300 lb.
- Raised Height 138" (11.5ft)
- Reach Distance of 19.7"
- Adjustable Forks 8.7-29.1"
- Fork Length 45.3"
- Curtis Instrument Controllers
- EPS (Electronic Power Steering)
- 24V AC Drive Motor
- 24V Lift Motor
- Battery 24V/270Ah
- Polyurethane Wheels
- Ergonomic Handle and Controls
- Steel Construction
- Robotic Welding
- Charger
- 3 Year Limited Warranty

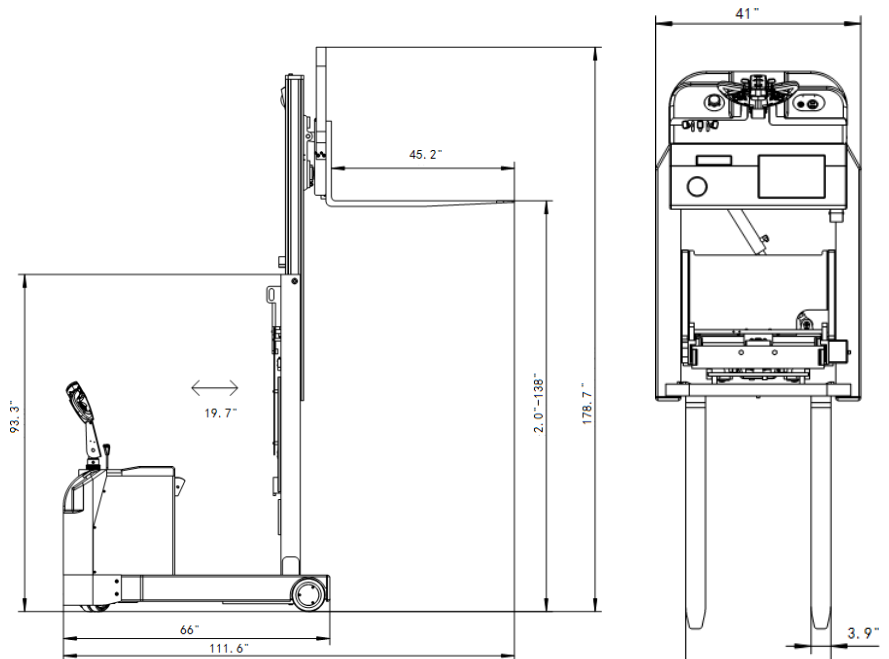

EK14S-130 Counterbalanced Stacker

The EKKO EK14S-130 Fully Powered Counterbalanced Walkie Stacker is designed with the combination of the versatility of a forklift and a walkie stacker. It is ideal for loading and unloading trucks, loading docks, stock rooms, manufacturing floors and warehousing.

Made from high quality steel and components with durable quality drives to withstand any terrain, usage, impact and directional changes for the use of any application with confidence and assurance.

- Load Capacity 3300 lb.
- Raised Height 130" (10.8ft)
- **Side-shift**
- Adjustable Forks 8.6-28.3"
- Tilt 2/5 degree
- Fork Length 45.3"
- Curtis Instrument Controller
- EPS (Electronic Power Steering)
- 24V ZF AC Drive Motor
- 24V Lift Motor
- Polyurethane Wheels
- Ergonomic Handle and Controls
- Steel Construction
- Robotic Welding
- 3 Year Limited Warranty



Model		EK14S-130
Lift		Electric
Drive		Electric
Load capacity	(lb.)	3300
Load center distance	(in)	24
Wheelbase	(in)	47
Lifting height	(in)	130
Side Shift		3 Way Valve
Lowered mast height	(in)	84
Extended mast height	(in)	167
Mast Carriage Tilt	(°)	2/5
Overall length	(in)	109
Overall width	(in)	39
Fork size, Thick/Width/Length	(in)	1.4/4/45.3
Fork adjust width	(in)	8.6-28.3
Turning radius	(in)	57
Gradient performance, laden/unladen	(%)	6/10
Lift speed, laden/unladen	(in/s)	4/5.1
Lowering speed, laden/unladen	(in/s)	5.3/4.7
Charger	(V/A)	24V/30A
Driving Motor	(V/W)	AC 24V/2500W
Lifting Motor	(V/W)	24V/2500W
EPS Steering Motor	(V/W)	24/200W
Battery voltage	(V/Ah)	24V/210Ah (Side)
Service Weight	(lb.)	3840

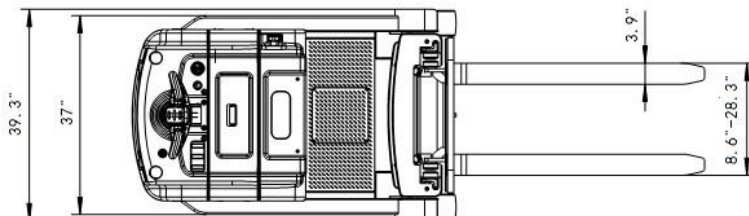
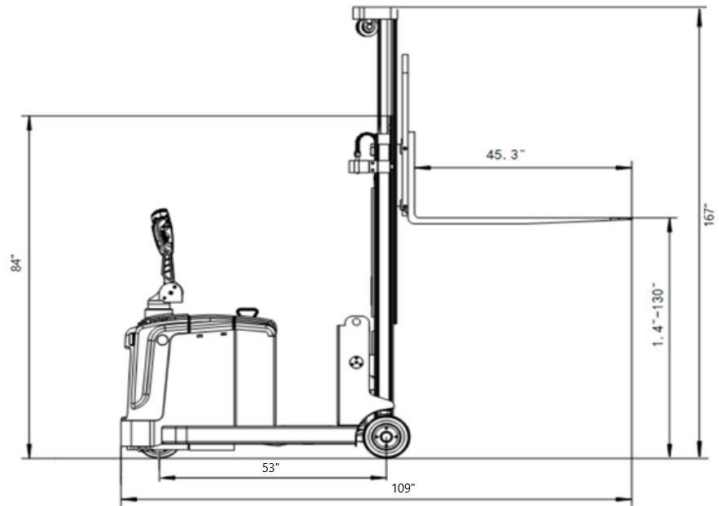

EK13S-177 Counterbalanced Stacker

The EKKO EK13S-177 Fully Powered Counterbalanced Walkie Stacker is designed with the combination of the versatility of a forklift and a walkie stacker. It is ideal for loading and unloading trucks, loading docks, stock rooms, manufacturing floors and warehousing.

Made from high quality steel and components with durable quality drives to withstand any terrain, usage, impact and directional changes for the use of any application with confidence and assurance.

- Load Capacity 2860 lb.
- Raised Height 177" (14.75ft)
- **Side-shift**
- Adjustable Forks 8.6-28.3"
- Tilt 2/5 degree
- Fork Length 45.3"
- Curtis Instrument Controller
- EPS (Electronic Power Steering)
- 24V ZF AC Drive Motor
- 24V Lift Motor
- Polyurethane Wheels
- Ergonomic Handle and Controls
- Steel Construction
- Robotic Welding
- 3 Year Limited Warranty



Model		EK13S-177
Lift		Electric
Drive		Electric
Load capacity	(lb.)	2860
Load center distance	(in)	24
Wheelbase	(in)	46.81
Lifting height	(in)	177
Side Shift		3 Way Valve
Lowered mast height	(in)	78.74
Extended mast height	(in)	214.53
Mast Carriage Tilt	(°)	2/5
Overall length	(in)	107.8
Overall width	(in)	39
Fork size, Thick/Width/Length	(in)	1.4/4/45.3
Fork adjust width	(in)	8.6-28.3
Turning radius	(in)	56.89
Gradient performance, laden/unladen	(%)	6/8
Lift speed, laden/unladen	(in/s)	3.9/4.7
Lowering speed, laden/unladen	(in/s)	5.3/4.7
Charger	(V/A)	24V/30A
Driving Motor	(V/W)	AC 24V/2500W
Lifting Motor	(V/W)	24V/2500W
EPS Steering Motor	(V/W)	24/200W
Battery voltage	(V/Ah)	24V/210Ah (Side)
Service Weight	(lb.)	4070

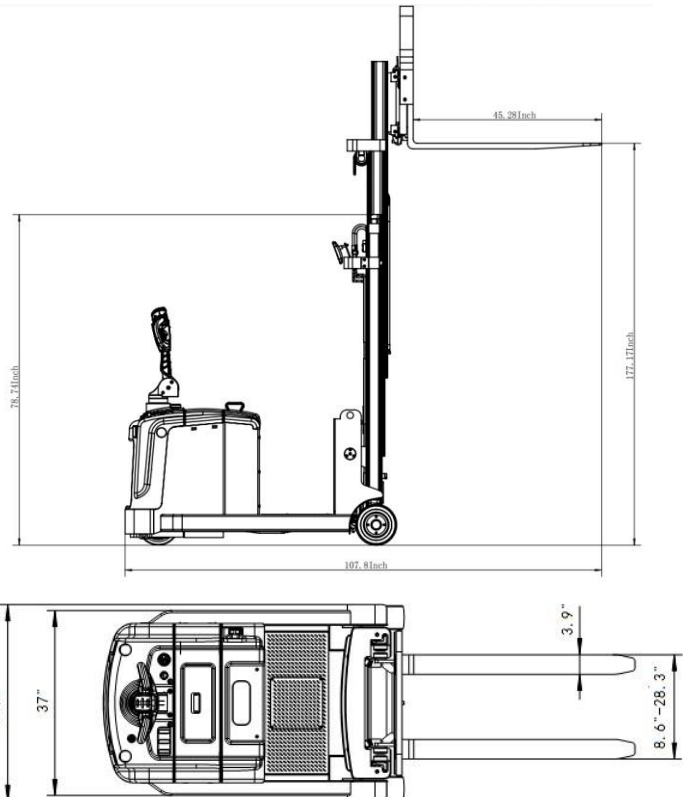

EK14-138 Counterbalanced Stacker

The EKKO EK14-138 Fully Powered Counterbalance Walkie Stacker is designed with the combination of the versatility of a forklift and a walkie stacker. It is ideal for loading and unloading trucks, loading docks, stock rooms, manufacturing floors and warehousing.

Made from high quality steel and components with durable quality drives to withstand any terrain, usage, impact and directional changes for the use of any application with confidence and assurance.

- Load Capacity 3300 lb.
- Raised Height 138" (10.8ft)
- Adjustable Forks 8.6-28.3"
- Tilt 2/5 degree
- Fork Length 45.3"
- Curtis Instrument Controller
- EPS (Electronic Power Steering)
- 24V ZF AC Drive Motor
- 24V Lift Motor
- Polyurethane Wheels
- Ergonomic Handle and Controls
- Steel Construction
- Robotic Welding
- 3 Year Limited Warranty



Model		EK14-138
Lift		Electric
Drive		Electric
Load capacity	(lb.)	3300
Load center distance	(in)	24
Wheelbase	(in)	47
Lifting height	(in)	138
Lowered mast height	(in)	84
Extended mast height	(in)	167
Mast/Fork carriage tilt forward/backward	(°)	2/5
Overall length	(in)	109
Overall width	(in)	39
Fork size, Thick/Width/Length	(in)	1.4/4/45.3
Fork adjust width	(in)	8.6-28.3
Turning radius	(in)	57
Gradient laden/unladen	(%)	6/10
Lift speed, laden/unladen	(in/s)	4/5.1
Lowering speed, laden/unladen	(in/s)	5.3/4.7
Charger	(V/A)	24V/30A
Driving Motor	(V/W)	AC 24V/2500W
Lifting Motor	(V/W)	24V/2500W
EPS Steering Motor	(V/W)	24/200W
Battery voltage	(V/Ah)	24V/210Ah
Service Weight	(lb.)	3840

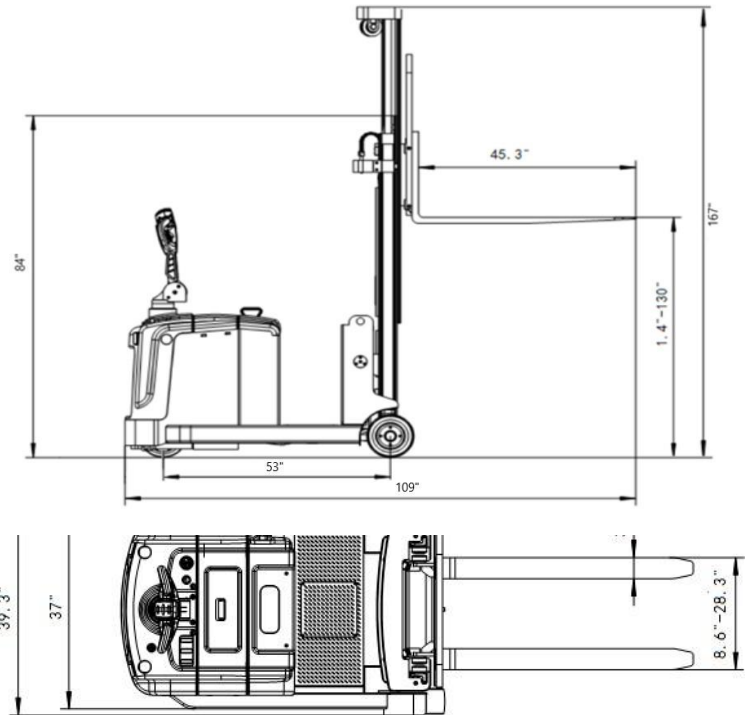

EK14 Counterbalance Stacker

The EKKO EK14 Fully Powered Counterbalance Walkie Stacker is designed with the combination of versatility of a forklift and a walkie stacker. It is ideal for loading and unloading trucks, loading docks, stock rooms, manufacturing floors and warehousing.

Made from high quality steel and Components with durable quality drives to withstand any terrain, usage, impact and directional changes for the use of any application with confidence and assurance.

- Load Capacity 3300 lb.
- Raised Height 118" (9.83ft)
- Adjustable Forks 8.6-28.3"
- Tilt 2/5 degree
- Fork Length 45.3"
- Curtis Instrument Controller
- EPS (Electronic Power Steering)
- 24V AC Drive Motor
- 24V Lift Motor
- Polyurethane Wheels
- Ergonomic Handle and Controls
- Steel Construction
- Robotic Welding
- 3 Year Limited Warranty

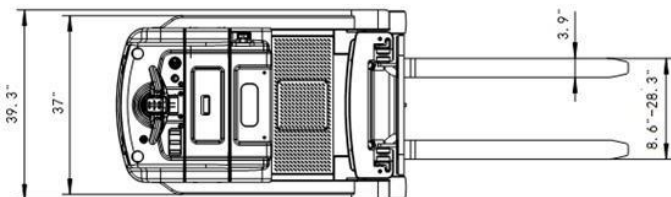
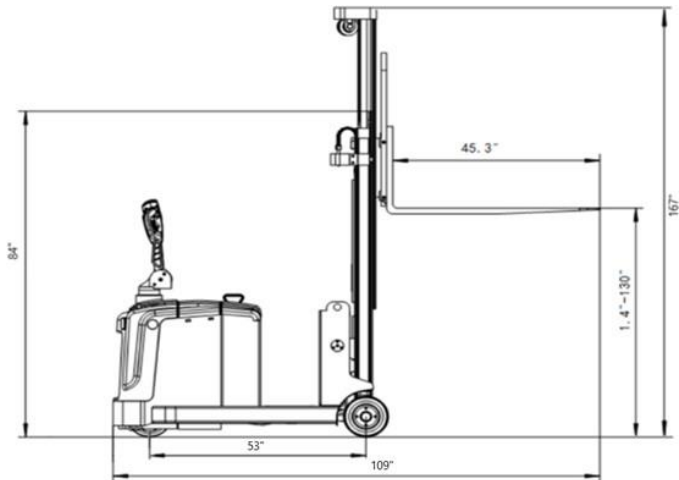

Model		EK14
Lift		Electric
Drive		Electric
Load capacity	(lb.)	3300
Load center distance	(in)	24
Wheelbase	(in)	47
Lifting height	(in)	118
Lowered mast height	(in)	78
Extended mast height	(in)	155
Mast/Fork carriage tilt forward/backward	(°)	2/5
Overall length	(in)	109
Overall width	(in)	39
Fork size, Thick/Width/Length	(in)	1.4/4/45.3
Fork adjust width	(in)	8.6-28.3
Turning radius	(in)	57
Gradient laden/unladen	(%)	6/10
Lift speed, laden/unladen	(in/s)	4/5.1
Lowering speed, laden/unladen	(in/s)	5.3/4.7
Charger	(V/A)	24V/30A
Driving Motor	(V/W)	AC 24V/2500W
Lifting Motor	(V/W)	24V/2500W
EPS Steering Motor	(V/W)	24/200W
Battery voltage	(V/Ah)	24V/210Ah
Service Weight	(lb.)	3740

EK07S Counterbalance Walkie Stacker



Model		EK07S
Lift		Electric
Drive		Electric
Load capacity	(lb.)	1550
Load center distance	(in)	20
Lifting height	(in)	118
Lowered mast height	(in)	81.1
Overall length	(in)	84.7
Overall width	(in)	34.5
Fork size, Thick/Width/Length	(in)	1.4/2.9/42
Fork adjust width	(in)	8.3-25.2
Turning radius	(in)	51
Charger	(V/A)	24V/20A
Driving Motor	(V/W)	AC 24V/750W
Lifting Motor	(V/W)	24V/1500W
Battery voltage	(V/Ah)	24V/120Ah
Service Weight	(lb.)	2175

The EKKO EK07S Fully Powered Counterbalance Walkie Stacker is designed with the combination of the versatility of a forklift and a walkie stacker. It is ideal for loading and unloading trucks, loading docks, stock rooms, manufacturing floors and warehousing.

Made from high quality steel and components with durable quality drives to withstand any terrain, usage, impact and directional changes for the use of any application with confidence and assurance.

- Load Capacity 1550 lb.
- Raised Height 118" (9.83ft)
- Adjustable Forks 8.3-25.2"
- Fork Length 42"
- Curtis Instrument Controller
- 24V AC Drive Motor
- 24V Lift Motor
- Polyurethane Wheels
- Ergonomic Handle and Controls
- Steel Construction
- Robotic Welding
- 3 Year Limited Warranty

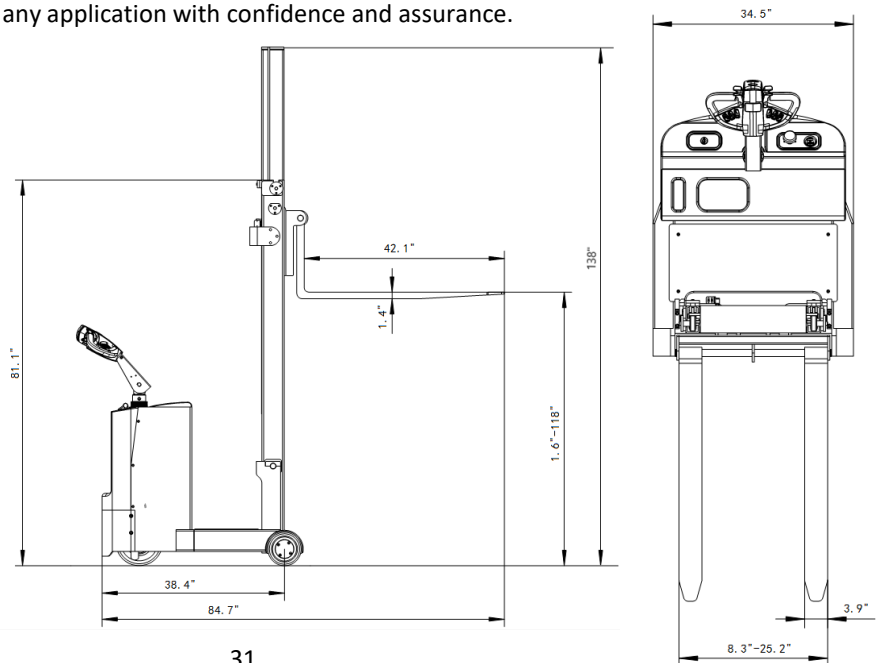

EB16EAS-189LI Lithium-Iron Walkie Stacker

The EKKO EB16EAS-189LI Electric Straddle Stacker is designed with the combination of the versatility of a forklift, reach truck and a walkie stacker with SIDE-SHIFTING capabilities. It is ideal for loading and unloading trucks, loading docks, stock rooms, manufacturing floors and warehousing.

Made from high quality steel and components with durable quality drives to withstand any terrain, usage, impact and directional changes for the use of any application with confidence and assurance.

- Load Capacity 4400 lb.
- Raised Height 189"
- Side-Shift
- Adjustable Forks 8.27-31.5"
- Adjustable Legs 38.06-51.8"
- Fork Length 45.3"
- Free Lift 51.85"
- EPS (Electric Power Steering)
- Curtis Instrument Controller
- 24V Center AC Drive Motor
- 24V Lift Motor
- Triple Mast
- Battery 24V/210Ah
- Ergonomic Handle and Controls
- Steel Construction
- Robotic Welding
- 3 Year Limited Warranty



Model		EB16EAS-189LI
Load capacity	(lb.)	4400
The max. lifting height	(in)	189
Load center distance	(in)	23.62
Free Lift	(in)	51.85
EPS (Elec. Power Steer)		Yes
Fork length	(in)	45.28
Single fork width	(in)	4.7
Overall fork width	(in)	8.27-31.5
Lowered fork height	(in)	1.57
Fixed leg length	(in)	42
Adjustable legs	(in)	38.06-51.81
Turning radius	(in)	68.5
Overall length	(in)	83.26
Max width	(in)	46.93-60.71
Extended mast height	(in)	227
Lowered mast height	(in)	88.86
Battery voltage	(V/Ah)	24/150Ah Li
Charger	(V/A)	24V/30A
Lifting Motor	(W)	3000 Watt, Lift speed, laden/unladen:95/160m/s Lowering speed, laden/unladen:130/110mm/s
AC Driving Motor	(W)	3000 Watt, Driving speed: laden/unladen: 5.2/5.5km/h
Service Weight	(lb.)	3520

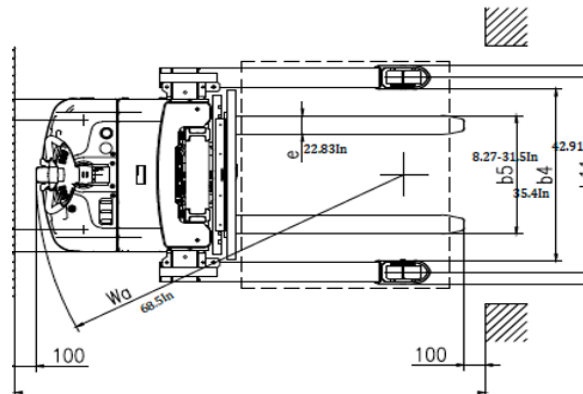
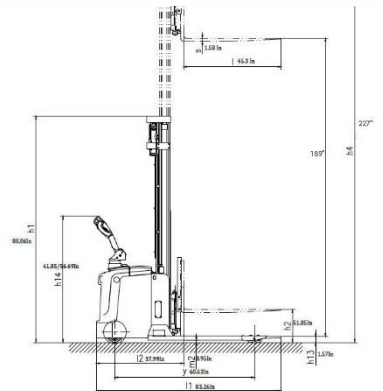

EB16EA Full Powered Walkie Stacker

The EKKO EB16EA Electric Straddle Stacker is designed with the combination of the versatility of a forklift, walkie stacker. It is ideal for loading and unloading trucks, loading docks, stock rooms, manufacturing floors and warehousing.

Made from high quality steel and components with durable quality drives to withstand any terrain, usage, impact and directional changes for the use of any application with confidence and assurance.

- Load Capacity 4400 lb.
- Raised Height 216"
- Adjustable Forks 9.8-31.5"
- Adjustable Legs 38.06-51.8"
- Fork Length 45.28"
- Free Lift 76.25"
- EPS (Electric Power Steering)
- Curtis Instrument Controller
- 24V Center AC Drive Motor
- 24V Lift Motor
- Triple Mast
- Battery 24V/210Ah
- Polyurethane Wheels
- Ergonomic Handle and Controls
- Steel Construction
- Robotic Welding
- 3 Year Limited Warranty



Model		EB16EA
Load capacity	(lb.)	4400
The max. lifting height	(in)	216
Load center distance	(in)	24
Free Lift	(in)	76.25
EPS (Elec. Power Steer)		Yes
Fork length	(in)	45.28
Single fork width	(in)	4.7
Overall fork width	(in)	9.8-31.5
Lowered fork height	(in)	1.58
Fixed leg length	(in)	42
Adjustable legs	(in)	38.06-51.81
Turning radius	(in)	69.09
Overall length	(in)	81.69
Max width	(in)	46.93-60.71
Extended mast height	(in)	253.15
Lowered mast height	(in)	98.03
Battery voltage	(V/Ah)	24/210Ah
Charger	(V/A)	24V/30A
Lifting Motor	(W)	3000 Watt, Lift speed, laden/unladen:95/160m/s Lowering speed, laden/unladen:130/110mm/s
AC Driving Motor	(W)	3000 Watt, Driving speed: laden/unladen: 5.2/5.5km/h
Service Weight	(lb.)	3542

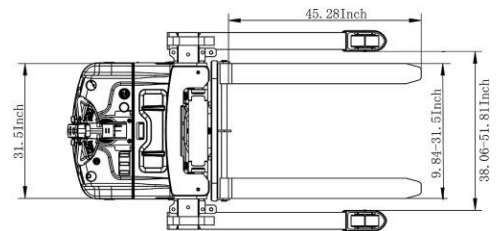
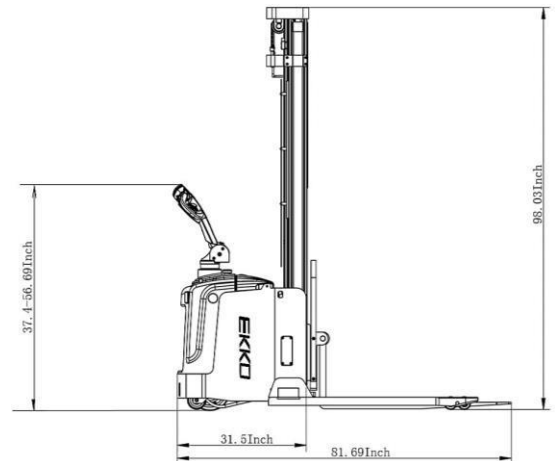

EB20E Full Powered Walkie Stacker

The EKKO EB20E Electric Straddle Stacker is designed with the combination of the versatility of a forklift, reach truck and a walkie stacker. It is ideal for loading and unloading trucks, loading docks, stock rooms, manufacturing floors and warehousing.

Made from high quality steel and components with durable quality drives to withstand any terrain, usage, impact and directional changes for the use of any application with confidence and assurance.

- Load Capacity 4400 lb.
- Raised Height 177"
- Adjustable Forks 9.8-31.5"
- Adjustable Legs 45.5-59.1"
- Fork Length 45.3"
- Curtis Instrument Controller
- 24V AC Drive Motor
- 24V Lift Motor
- Triple Mast
- Battery 24V/210Ah
- Polyurethane Wheels
- Ergonomic Handle and Controls
- Steel Construction
- Robotic Welding
- 3 Year Limited Warranty



Model		EB20E
Load capacity	(lb.)	4400
The max. lifting height	(in)	177
Load center distance	(in)	24
Fork length	(in)	45.3
Single fork width	(in)	4.7
Overall fork width	(in)	9.8-31.5
Lowered fork height	(in)	3
Fixed leg length	(in)	42
Adjustable legs	(in)	45.5-59.1
Turning radius	(in)	60
Overall length	(in)	85
Max width	(in)	61
Extended mast height	(in)	198
Lowered mast height	(in)	85
Battery voltage	(V/Ah)	24/210Ah
The charger	(V/A)	24V/30A
Lifting Motor	(V/W)	3000W, Lift speed, laden/unladen:92/136mm/s Lowering speed, laden/unladen:112/98mm/s
Driving Motor	(W)	1500W, Driving speed: laden/unladen:4.0/4.2km/h
Service Weight	(lb.)	2800

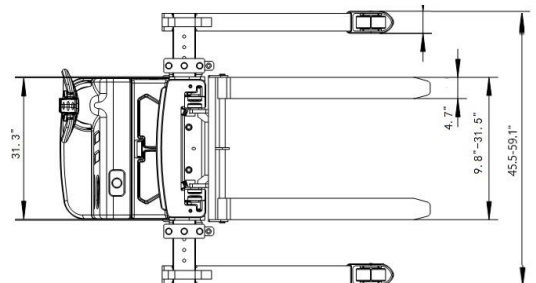
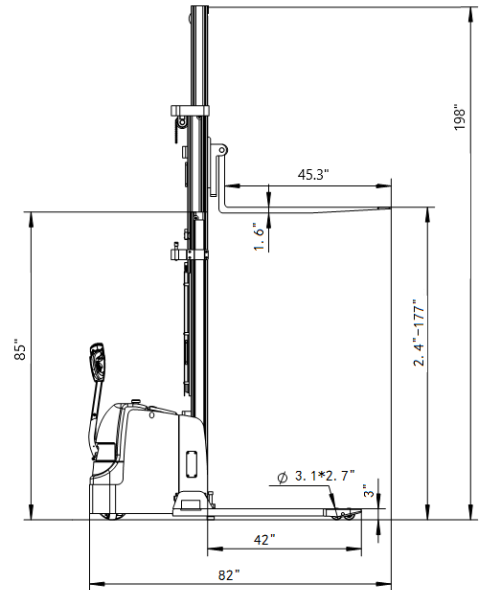

EB18E Full Powered Walkie Stacker

The EKKO EB18E Electric Straddle Stacker is designed with the combination of the versatility of a forklift, reach truck and a walkie stacker. It is ideal for loading and unloading trucks, loading docks, stock rooms, manufacturing floors and warehousing.

Made from high quality steel and components with durable quality drives to withstand any terrain, usage, impact and directional changes for the use of any application with confidence and assurance.

- Load Capacity 4000 lb.
- Raised Height 138"
- Adjustable Forks 9.8-31.5"
- Adjustable Legs 45.5-59.1"
- Fork Length 45.3"
- Curtis Instrument Controller
- 24V AC Drive Motor
- 24V Lift Motor
- Battery 24V/160Ah
- Polyurethane Wheels
- Ergonomic Handle and Controls
- Steel Construction
- Robotic Welding
- 3 Year Limited Warranty



Model		EB18E
Load capacity	(lb.)	4000
The max. lifting height	(in)	138
Load center distance	(in)	24
Fork length	(in)	45.3
Single fork width	(in)	4.7
Overall fork width	(in)	9.8-31.5
Lowered fork height	(in)	2.35
Fixed leg length	(in)	36.5
Adjustable legs	(in)	45.5-59.1
Turning radius	(in)	60
Overall length	(in)	82
Max width	(in)	61
Extended mast height	(in)	154
Lowered mast height	(in)	91.3
Battery voltage	(V/Ah)	2x12V/160Ah
The charger	(V/A)	24V/20A
Lifting Motor	(W)	3000 Watt, Lift speed, laden/unladen:92/136mm/s Lowering speed, laden/unladen:112/98mm/s
Driving Motor	(W)	1500 Watt, Driving speed: laden/unladen:4.0/4.2km/h
Service Weight	(lb.)	2100

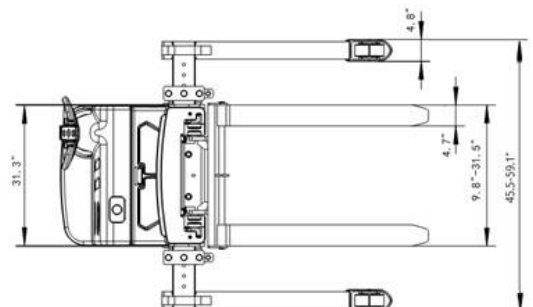
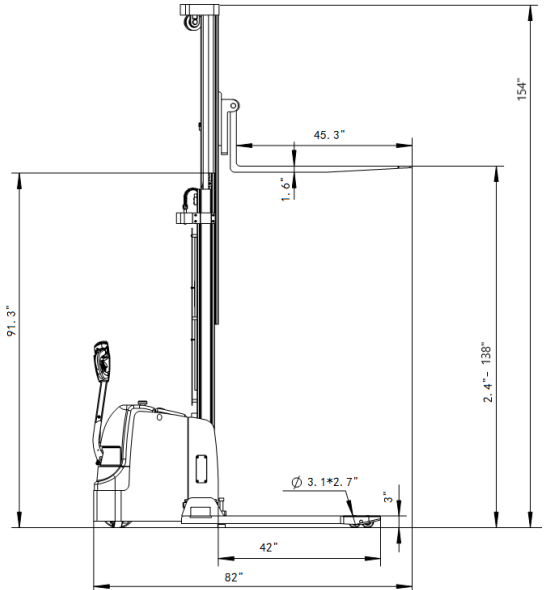

EB13E-138 Full Powered Walkie Stacker

The EKKO EB13E-138 Electric Straddle Stacker is designed with the combination of the versatility of a forklift, reach truck and a walkie stacker. It is ideal for loading and unloading trucks, loading docks, stock rooms, manufacturing floors and warehousing.

Made from high quality steel and components with durable quality drives to withstand any terrain, usage, impact and directional changes for the use of any application with confidence and assurance.

- Load Capacity 2800 lb.
- Raised Height 138"
- Adjustable Forks 8.3-33.5"
- Adjustable Legs 45.7-59.1"
- Fork Length 45.3"
- Curtis Instrument Controller
- **24V Center Drive Motor**
- 24V Lift Motor
- Battery 2*12V/100Ah
- Polyurethane Wheels
- Ergonomic Handle and Controls
- Steel Construction
- Robotic Welding
- 3 Year Limited Warranty

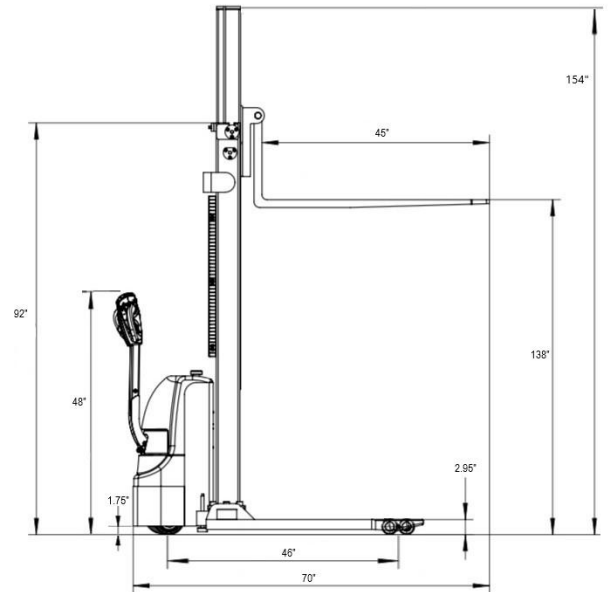

Model		EB13E-138
Load capacity	(lb.)	2800
The max. lifting height	(in)	138"
Load center distance	(in)	24
Fork length	(in)	45.3
Single fork width	(in)	4
Overall fork width	(in)	8.3-33.5
Lowered fork height	(in)	2.35
Fixed leg length	(in)	36.5
Adjustable legs	(in)	45.5-59.1
Turning radius	(in)	52.6
Overall length	(in)	70
Max Overall width	(in)	61
Extended mast height	(in)	154
Lowered mast height	(in)	92
Battery voltage (dimensions)	(in)	2×12V/100AH (10/6.6/8.5)
Internal Charger	(V/A)	24V/15A
Lifting Motor	(V/W)	2000 Watt, Lift speed, laden/unladen:92/136mm/s Lowering speed, laden/unladen:112/98mm/s
Driving Motor	(W)	750 Watt, Driving speed: laden/unladen:4.0/4.2km/h
Service Weight	(lb.)	1450



EB13E Full Powered Walkie Stacker

The EKKO EB13E Electric Straddle Stacker is designed with the combination of the versatility of a forklift, reach truck and a walkie stacker. It is ideal for loading and unloading trucks, loading docks, stock rooms, manufacturing floors and warehousing.

Made from high quality steel and components with durable quality drives to withstand any terrain, usage, impact and directional changes for the use of any application with confidence and assurance.

- Load Capacity 2800 lb.
- Raised Height 119"
- Adjustable Forks 8.3-33.5"
- Adjustable Legs 45.7-59.1"
- Fork Length 45.3"
- Curtis Instrument Controller
- **24V Center Drive Motor**
- 24V Lift Motor
- Battery 2*12V/100Ah
- Polyurethane Wheels
- Ergonomic Handle and Controls
- Steel Construction
- Robotic Welding
- 3 Year Limited Warranty

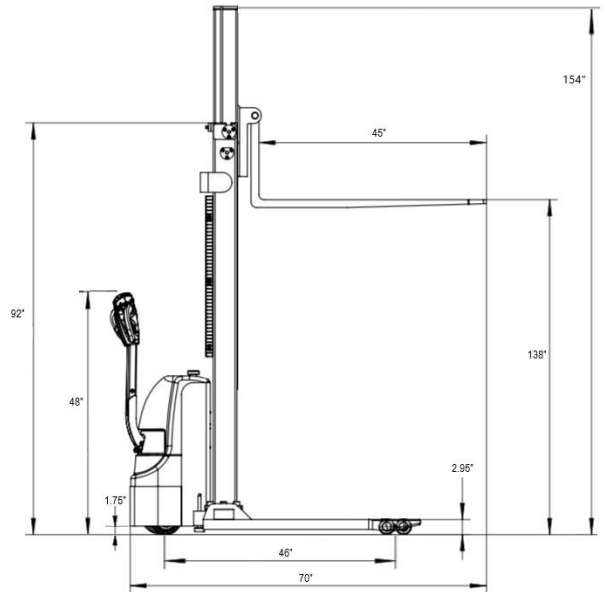

Model		EB13E
Load capacity	(lb.)	2800
The max. lifting height	(in)	119"
Load center distance	(in)	24
Fork length	(in)	45.3
Single fork width	(in)	4
Overall fork width	(in)	8.3-33.5
Lowered fork height	(in)	2.35
Fixed leg length	(in)	36.5
Adjustable legs	(in)	45.5-59.1
Turning radius	(in)	52.6
Overall length	(in)	70
Max Overall width	(in)	61
Extended mast height	(in)	135
Lowered mast height	(in)	82
Battery voltage (dimensions)	(in)	2×12V/100AH (10/6.6/8.5)
Internal Charger	(V/A)	24V/15A
Lifting Motor	(V/W)	2000 Watt, Lift speed, laden/unladen:92/136mm/s Lowering speed, laden/unladen:112/98mm/s
Driving Motor	(W)	750 Watt, Driving speed: laden/unladen:4.0/4.2km/h
Service Weight	(lb.)	1450

EB13E-Li Lithium-Iron Walkie Stacker



The EKKO EB13E-Li Lithium Electric Straddle Stacker is designed with the combination of the versatility of a forklift, reach truck and a walkie stacker. It is ideal for loading and unloading trucks, loading docks, stock rooms, manufacturing floors and warehousing.

Made from high quality steel and components with durable quality drives to withstand any terrain, usage, impact and directional changes for the use of any application with confidence and assurance.

- Load Capacity 2800 lb.
- Raised Height 119"
- Adjustable Forks 8.3-33.5"
- Adjustable Legs 45.7-59.1"
- Fork Length 45.3"
- Curtis Instrument Controller
- **24V Center Drive Motor**
- 24V Lift Motor
- Battery 24V/50Ah Lithium
- Polyurethane Wheels
- Ergonomic Handle and Controls
- Steel Construction
- Robotic Welding
- 3 Year Limited Warranty

Model		EB13E-Li
Load capacity	(lb.)	2800
The max. lifting height	(in)	119"
Load center distance	(in)	24
Fork length	(in)	45.3
Single fork width	(in)	4
Overall fork width	(in)	8.3-33.5
Lowered fork height	(in)	2.35
Fixed leg length	(in)	36.5
Adjustable legs	(in)	45.5-59.1
Turning radius	(in)	52.6
Overall length	(in)	70
Max Overall width	(in)	61
Extended mast height	(in)	135
Lowered mast height	(in)	82
Battery voltage	(V/A)	24V-50AH Lithium
Internal Charger	(V/A)	24V/15A
Lifting Motor	(V/W)	2000 Watt, Lift speed, laden/unladen:92/136mm/s Lowering speed, laden/unladen:112/98mm/s
Driving Motor	(W)	750 Watt, Driving speed: laden/unladen:4.0/4.2km/h
Service Weight	(lb.)	1325



EB13E-138Li Lithium-Iron Walkie Stacker

The EKKO EB13-138LI Lithium Electric Straddle Stacker is designed with the combination of the versatility of a forklift, reach truck and a walkie stacker. It is ideal for loading and unloading trucks, loading docks, stock rooms, manufacturing floors and warehousing.

Made from high quality steel and components with durable quality drives to withstand any terrain, usage, impact and directional changes for the use of any application with confidence and assurance.

- Load Capacity 2800 lb.
- Raised Height 138"
- Adjustable Forks 8.3-33.5"
- Adjustable Legs 45.7-59.1"
- Fork Length 45.3"
- Curtis Instrument Controller
- **24V Center Drive Motor**
- 24V Lift Motor
- Battery 24V/50Ah Lithium
- Polyurethane Wheels
- Ergonomic Handle and Controls
- Steel Construction
- Robotic Welding
- 3 Year Limited Warranty



Model		EB13E-138Li
Load capacity	(lb.)	2800
The max. lifting height	(in)	138"
Load center distance	(in)	24
Fork length	(in)	45.3
Single fork width	(in)	4
Overall fork width	(in)	8.3-33.5
Lowered fork height	(in)	2.35
Fixed leg length	(in)	36.5
Adjustable legs	(in)	45.5-59.1
Turning radius	(in)	52.6
Overall length	(in)	70
Max Overall width	(in)	61
Extended mast height	(in)	154
Lowered mast height	(in)	92
Battery voltage	(V/A)	24V/50AH Lithium
Internal Charger	(V/A)	24V/15A
Lifting Motor	(V/W)	2000 Watt, Lift speed, laden/unladen:92/136mm/s Lowering speed, laden/unladen:112/98mm/s
Driving Motor	(W)	750 Watt, Driving speed: laden/unladen:4.0/4.2km/h
Service Weight	(lb.)	1365

EB13E-145Li Lithium-Iron Walkie Stacker



Model		EB13E-145Li
Load capacity	(lb.)	2800
The max. lifting height	(in)	145"
Load center distance	(in)	24
Fork length	(in)	45.3
Single fork width	(in)	4
Overall fork width	(in)	8.3-33.5
Lowered fork height	(in)	2.35
Fixed leg length	(in)	36.5
Adjustable legs	(in)	45.5-59.1
Turning radius	(in)	52.6
Overall length	(in)	70
Max Overall width	(in)	61
Extended mast height	(in)	167
Lowered mast height	(in)	95.66
Battery voltage	(V/A)	24V/50AH Lithium
Internal Charger	(V/A)	24V/15A
Lifting Motor	(V/W)	2000 Watt, Lift speed, laden/unladen:92/136mm/s Lowering speed, laden/unladen:112/98mm/s
Driving Motor	(W)	750 Watt, Driving speed: laden/unladen:4.0/4.2km/h
Service Weight	(lb.)	1390

The EKKO EB13E-145Li Lithium Straddle Stacker is designed with the combination of the versatility of a forklift, reach truck and a walkie stacker. It is ideal for loading and unloading trucks, loading docks, stock rooms, manufacturing floors and warehousing.

Made from high quality steel and components with durable quality drives to withstand any terrain, usage, impact and directional changes for the use of any application with confidence and assurance.

- Load Capacity 2800 lb.
- Raised Height 145"
- Adjustable Forks 8.3-33.5"
- Adjustable Legs 45.7-59.1"
- Fork Length 45.3"
- Curtis Instrument Controller
- **24V Center Drive Motor**
- 24V Lift Motor
- Battery 24V/50Ah Lithium
- Polyurethane Wheels
- Ergonomic Handle and Controls
- Steel Construction
- Robotic Welding
- 3 Year Limited Warranty

EB13ES-145Li Lithium-Iron Walkie Stacker



The EKKO EB13ES-145Li Lithium Straddle Stacker with side-shift is designed with the combination of the versatility of a forklift, reach truck and a walkie stacker. It is ideal for loading and unloading trucks, loading docks, stock rooms, manufacturing floors and warehousing.

Made from high quality steel and components with durable quality drives to withstand any terrain, usage, impact and directional changes for the use of any application with confidence and assurance.

- LITHIUM LiFePO4
- 2640 lbs. Capacity
- 145 in. Lift Height
- **Side-Shift**
- Narrow Aisles 7 ft.
- Adjustable Legs 45.5-59.1 in.
- Adjustable Forks 8.3-33.5 in.
- 24V Center Drive Motor
- Curtis Instrument Controller
- Lithium Iron Phosphate Battery & Charger Included
- 3 Year Limited Warranty

Model		EB13E-145Li
Load capacity	(lb.)	2640
The max. lifting height	(in)	145"
Load center distance	(in)	24
Fork length	(in)	45.3
Side-Shift		
Single fork width	(in)	4
Overall fork width	(in)	8.3-33.5
Lowered fork height	(in)	2.35
Fixed leg length	(in)	36.5
Adjustable legs	(in)	45.5-59.1
Turning radius	(in)	52.6
Overall length	(in)	70
Max Overall width	(in)	61
Extended mast height	(in)	167
Lowered mast height	(in)	95.66
Battery voltage	(V/A)	24V/50AH Lithium
Internal Charger	(V/A)	24V/15A
Lifting Motor	(V/W)	2000 Watt, Lift speed, laden/unladen:92/136mm/s Lowering speed, laden/unladen:112/98mm/s
Driving Motor	(W)	750 Watt, Driving speed: laden/unladen:4.0/4.2km/h
Service Weight	(lb.)	1495



EB12EA Full Powered Walkie Stacker

The EKKO EB12EA Electric Straddle Stacker is designed with the combination of the versatility of a forklift, reach truck and a walkie stacker. It is ideal for loading and unloading trucks, loading docks, stock rooms, manufacturing floors and warehousing.

Made from high quality steel and components with durable quality drives to withstand any terrain, usage, impact and directional changes for the use of any application with confidence and assurance.

- Load Capacity 3000 lb.
- Raised Height 145.67"
- Adjustable Forks 8.3-33.5"
- Adjustable Legs 45.7-59.1"
- Fork Length 45.3"
- Curtis Instrument Controller
- **24V AC Drive Motor 1500 Watt**
- 24V Lift Motor
- Battery 2*12V/120Ah
- Polyurethane Wheels
- Ergonomic Handle and Controls
- Steel Construction
- Robotic Welding
- 3 Year Limited Warranty

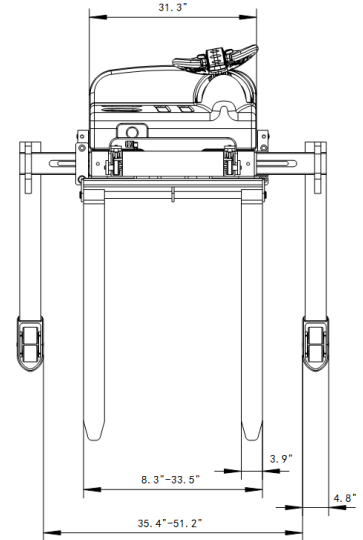
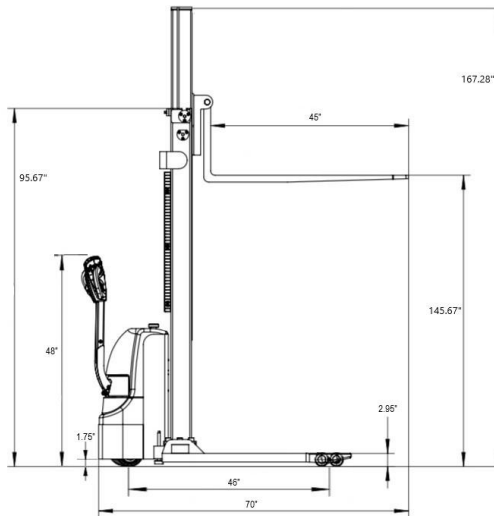

Model		EB12EA
Load capacity	(lb.)	3000
The max. lifting height	(in)	145.67"
Load center distance	(in)	24
Fork length	(in)	45.3
Single fork width	(in)	4
Overall fork width	(in)	8.3-33.5
Lowered fork height	(in)	2.35
Fixed leg length	(in)	36.5
Adjustable legs	(in)	45.5-59.1
Turning radius	(in)	52.6
Overall length	(in)	70
Max Overall width	(in)	61
Extended mast height	(in)	167.28
Lowered mast height	(in)	95.67
Battery voltage (dimensions)	(in)	2 × 12V/120AH (10/6.6/8.5)
Internal Charger	(V/A)	24V/15A
Lifting Motor	(V/W)	2200 Watt, Lift speed, laden/unladen:92/136mm/s Lowering speed, laden/unladen:112/98mm/s
Driving Motor	(W)	1500 Watt, Driving speed: laden/unladen: 4.0/4.2km/h
Service Weight	(lb.)	1584

AC Drive Motor
1500 Watt



EB12E-138 Full Powered Walkie Stacker

The EKKO EB12E-138 Electric Straddle Stacker is designed with the combination of the versatility of a forklift, reach truck and a walkie stacker. It is ideal for loading and unloading trucks, loading docks, stock rooms, manufacturing floors and warehousing.

Made from high quality steel and components with durable quality drives to withstand any terrain, usage, impact and directional changes for the use of any application with confidence and assurance.

- Load Capacity 2640 lb.
- Raised Height 138"
- Adjustable Forks 8.3-33.5"
- Adjustable Legs 45.7-59.1"
- Fork Length 45.3"
- Curtis Instrument Controller
- 24V Drive Motor
- 24V Lift Motor
- Battery 2*12V/100Ah
- Polyurethane Wheels
- Ergonomic Handle and Controls
- Steel Construction
- Robotic Welding
- 3 Year Limited Warranty

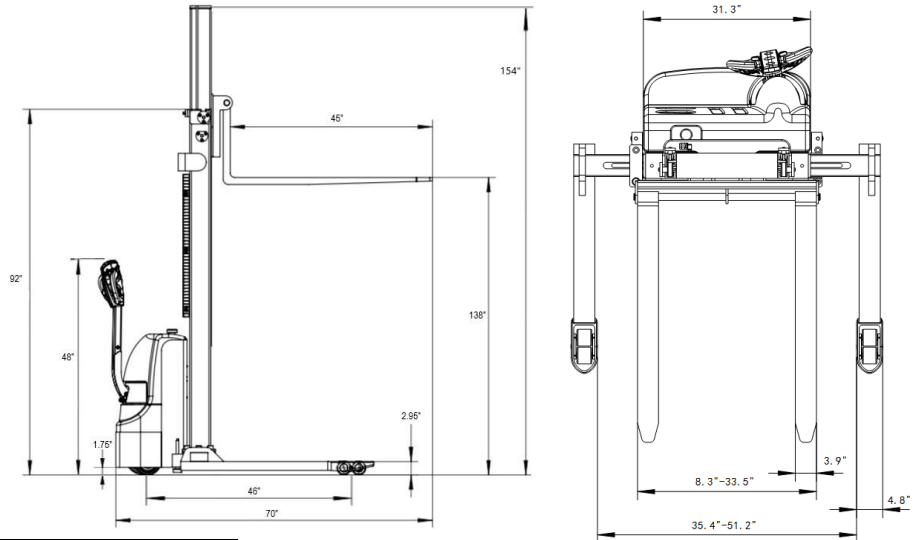

Model		EB12E-138
Load capacity	(lb.)	2640
The max. lifting height	(in)	138"
Load center distance	(in)	24
Fork length	(in)	45.3
Single fork width	(in)	4
Overall fork width	(in)	8.3-33.5
Lowered fork height	(in)	2.35
Fixed leg length	(in)	36.5
Adjustable legs	(in)	45.5-59.1
Turning radius	(in)	52.6
Overall length	(in)	70
Max Overall width	(in)	61
Extended mast height	(in)	154
Lowered mast height	(in)	92
Battery voltage (dimensions)	(in)	2×12V/100AH (10/6.6/8.5)
Internal Charger	(V/A)	24V/15A
Lifting Motor	(V/W)	2.2kw. Lift speed, laden/unladen:92/136mm/s Lowering speed, laden/unladen:112/98mm/s
Driving Motor	(W)	0.75kw. Driving speed: laden/unladen:4.0/4.2km/h
Service Weight	(lb.)	1450



EB12E Full Powered Walkie Stacker

The EKKO EB12E Electric Straddle Stacker is designed with the combination of the versatility of a forklift, reach truck and a walkie stacker. It is ideal for loading and unloading trucks, loading docks, stock rooms, manufacturing floors and warehousing.

Made from high quality steel and components with durable quality drives to withstand any terrain, usage, impact and directional changes for the use of any application with confidence and assurance.

- Load Capacity 2640lbs.
- Raised Height 119.4"
- Adjustable Forks 8.3-33.5"
- Adjustable Legs 45.7-59.1"
- Fork Length 45.3"
- Curtis Instrument Controller
- 24V Drive Motor
- 24V Lift Motor
- Battery 2*12V/100Ah
- Polyurethane Wheels
- Ergonomic Handle and Controls
- Steel Construction
- Robotic Welding
- 3 Year Limited Warranty

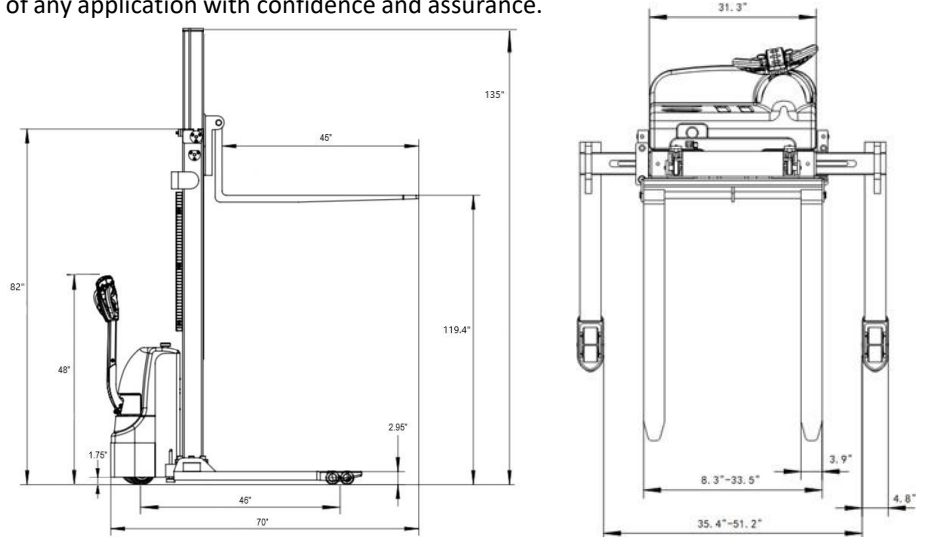

Model		EB12E
Load capacity	(lbs.)	2640
The max. lifting height	(in)	119.4"
Load center distance	(in)	24
Fork length	(in)	45.3
Single fork width	(in)	4
Overall fork width	(in)	8.3-33.5
Lowered fork height	(in)	2.35
Fixed leg length	(in)	36.5
Adjustable legs	(in)	45.5-59.1
Turning radius	(in)	52.6
Overall length	(in)	70
Max Overall width	(in)	61
Extended mast height	(in)	135
Lowered mast height	(in)	82
Battery voltage (dimensions)	(in)	2 × 12V/100AH (10/6.6/8.5)
Internal Charger	V/A	24V/15A
Lifting Motor	V/Kw	2.2kw. Lift speed, laden/unladen:92/136mm/s Lowering speed, laden/unladen:112/98mm/s
Driving Motor		0.75kw.Driving speed: laden/unladen:4.0/4.2km/h
Service Weight	(lbs.)	1420



EB12E-98Li LITHIUM-IRON Full Powered Walkie Stacker

The EKKO EB12E-98Li LITHIUM-IRON Phosphate Electric Straddle Stacker has a lowered mast of 7is designed with the combination of the versatility of a forklift, reach truck and a walkie stacker. It is ideal” which can get underneath any doorway for loading and unloading trucks, loading docks, stock rooms, manufacturing floors and warehousing.

Made from high quality steel and components with durable quality drives to withstand any terrain, usage, impact and directional changes for the use of any application with confidence and assurance.

- Load Capacity 2640lbs.
- Raised Height 98”
- Adjustable Forks 8.3-33.5”
- Adjustable Legs 45.7-59.1”
- Fork Length 45.3”
- Curtis Instrument Controller
- 24V Drive Motor
- 24V Lift Motor
- Battery LI-Iron LiFePO4 24/50Ah
- Polyurethane Wheels
- Ergonomic Handle and Controls
- Steel Construction
- Robotic Welding
- 3 Year Limited Warranty



Model		EB12E-98Li
Load capacity	(lbs.)	2640
The max. lifting height	(in)	98”
Load center distance	(in)	24
Fork length	(in)	45.3
Single fork width	(in)	4
Overall fork width	(in)	8.3-33.5
Lowered fork height	(in)	2.35
Fixed leg length	(in)	36.5
Adjustable legs	(in)	45.5-59.1
Turning radius	(in)	52.6
Overall length	(in)	70
Max Overall width	(in)	61
Extended mast height	(in)	114
Lowered mast height	(in)	72
Battery voltage (dimensions)	(in)	Li-Iron 24V/50Ah (10/6.6/8.5)
Internal Charger	V/A	24V/15A
Lifting Motor	V/Kw	2.2kw. Lift speed, laden/unladen:92/136mm/s Lowering speed, laden/unladen:112/98mm/s
Driving Motor		0.75kw. Driving speed: laden/unladen:4.0/4.2km/h
Service Weight	(lbs.)	1300

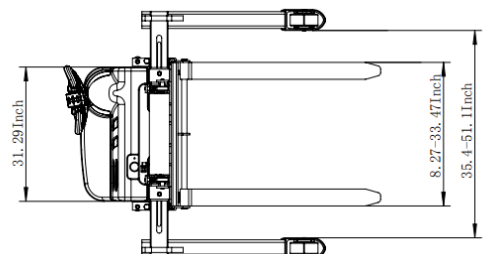
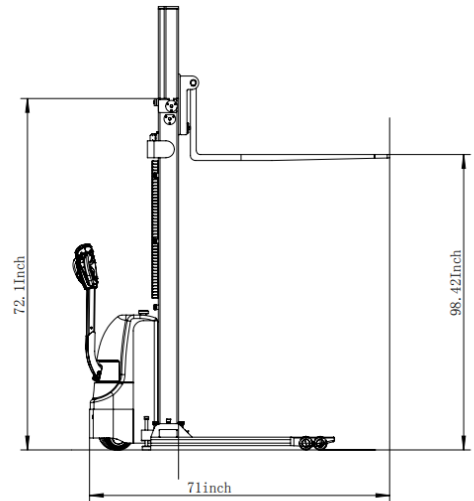

EA15B Semi-Electric Straddle Stacker



Model		EA15B
Load Capacity	(lb.)	3300
Lifting height Max.	(in)	119.4
Load center distance	(in)	24
Fork length	(in)	45.3
Single fork width	(in)	3.9
Overall fork width	(in)	8-33.4
Lowered fork height	(in)	2.4
Fixed leg length	(in)	34
Fixed leg width, single	(in)	3.9
Adjustable legs	(in)	43.5-59.1
Turning radius	(in)	53.2
Overall length	(in)	73
Overall width max	(in)	59
Extended mast height	(in)	140.5
Lowered mast height	(in)	84.5
Battery Voltage	(V/Ah)	12V/120Ah
Charger	(V/A)	12V/15A
Lift Motor	(V/W)	DC 12V/1500W
Service Weight	(lb.)	1200

The EKKO EA15B Semi-Electric Straddle Stacker is designed with the combination of the versatility of a forklift and a pallet stacker. It is ideal for loading and unloading trucks, loading docks, stock rooms, manufacturing floors and warehousing.

Made from high quality steel and components with durable quality drives to withstand any terrain, usage, impact and directional changes for the use of any application with confidence and assurance.

- Load Capacity 3300 lb.
- Raised Height 119.4" (9.95ft)
- Adjustable Forks 8.3-33.4"
- Adjustable Legs 43.5-59.1"
- Power Lifting
- Manual Drive
- External Charger 12V/15Ah
- Battery 12V/120Ah
- Ergonomic Handle
- Steel Construction
- Robotic Welding
- 3 Year Limited Warranty

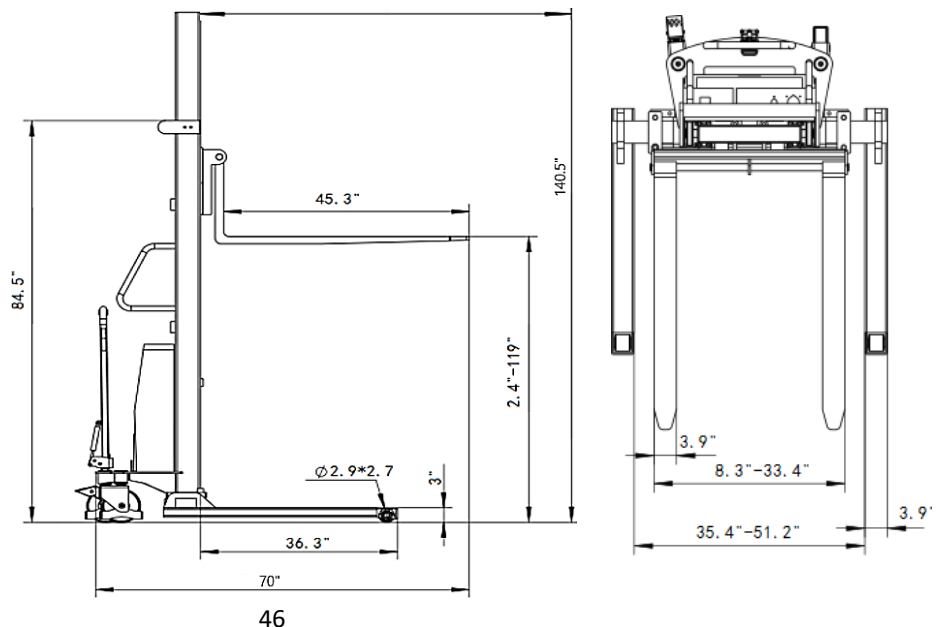

EA15C Semi-Electric Fork-Over Stacker



Model		EA15C
Load Capacity	(lb.)	3300
Lifting height Max.	(in)	119.4
Load center distance	(in)	24
Fork length	(in)	45.3
Single fork width	(in)	5.9
Overall fork width	(in)	24.5
Lowered fork height	(in)	2.4
Fixed leg length	(in)	45.3
Fixed leg width, single	(in)	5.9
Width between legs	(in)	23.2
Turning radius	(in)	53.2
Overall length	(in)	73
Overall width max	(in)	59
Extended mast height	(in)	140.5
Lowered mast height	(in)	81.8
Battery Voltage	(V/Ah)	12V/120Ah
Charger	(V/A)	12V/20A
Lift Motor	(V/W)	DC 12V/1500W
Service Weight	(lb.)	870

The EKKO EA15C Semi-Electric Fork-over Stacker is designed with the combination of the versatility of a forklift and a pallet stacker. It is ideal for loading and unloading trucks, loading docks, stock rooms, manufacturing floors and warehousing.

Made from high quality steel and components with durable quality drives to withstand any terrain, usage, impact and directional changes for the use of any application with confidence and assurance.

- Load Capacity 3300 lb.
- Raised Height 119.4" (9.95ft)
- Fork Width between Legs 12.75
- Power Lifting
- Manual Drive
- Internal Charger 12V/20Ah
- Battery 12V/120Ah
- Ergonomic Handle
- Steel Construction
- Robotic Welding
- 3 Year Limited Warranty

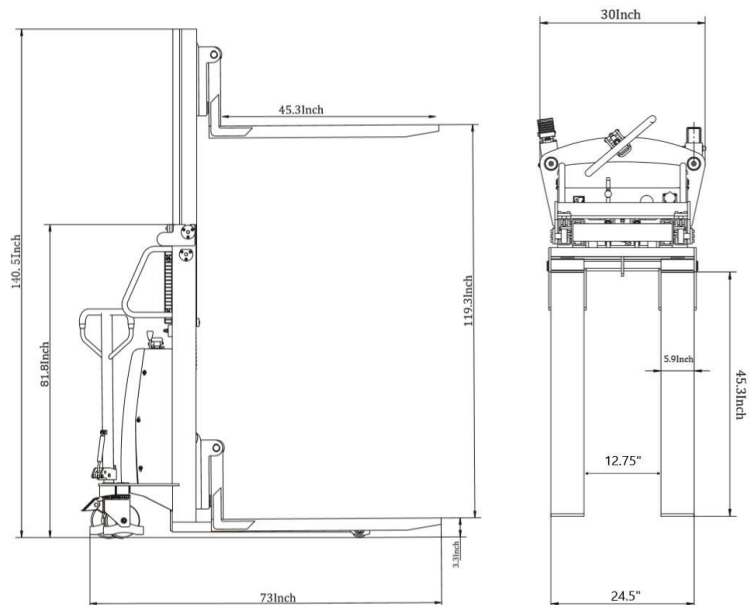

EA15D Semi-Electric Straddle Stacker

The EKKO EA15D Semi-Electric Straddle Stacker is designed with the combination of the versatility of a forklift and a pallet stacker. It is ideal for loading and unloading trucks, loading docks, stock rooms, manufacturing floors and warehousing.

Made from high quality steel and components with durable quality drives to withstand any terrain, usage, impact and directional changes for the use of any application with confidence and assurance.

- Load Capacity 3300lbs.
- Raised Height 138" (11.5ft)
- Adjustable Forks 8.3-33.5"
- Adjustable Legs 43.5-59.1"
- Fork Length 45.3"
- Power Lifting
- Manual Drive
- Adjustable Forks
- Built-in Charger 12v 120Ah
- Batteries Included
- Ergonomic Handle
- Steel Construction
- Robotic Welding
- 3 Years Limited Warranty

Model		EA15D
Load Capacity	(lb.)	3300
Lifting height Max.	(in)	138
Load center distance	(in)	24
Fork length	(in)	45.3
Single fork width	(in)	4
Overall fork width	(in)	8-32.7
Lowered fork height	(in)	2.35
Fixed leg length	(in)	36.5
Fixed leg width, single	(in)	3.94
Adjustable legs	(in)	44.5-59.1
Turning radius	(in)	52.6
Overall length	(in)	70
Overall width max	(in)	61
Extended mast height	(in)	154
Lowered mast height	(in)	84.5
Battery Voltage	(V/Ah)	12V/120Ah
Charger	(V/A)	12V/15A
Lift Motor	(V/W)	DC 12V/1500W
Service Weight	(lb.)	1450



EKKO EPC30A Center-Controlled Rider Pallet Jack

The EKKO EPC30A Center-Controlled Rider Pallet Jack is designed with the versatility of a pallet jack with full power lifting and driving capabilities. It is ideal for long hauls, loading and unloading trucks, loading docks, stock rooms, manufacturing floors and warehousing.

Made from high quality steel and components with durable quality drives to withstand any terrain, usage, impact and directional changes for the use of any application with confidence and assurance.

- Load Capacity 5000 lb.
- Fork Size 27x45"
- Curtis Instrument Controller
- German AC Drive
- Raised Height 7.88"
- Lowered Height 3.35"
- Polyurethane Wheels
- Ergonomic Handle and Controls
- Steel Construction
- Robotic Welding
- 3 Year Limited Warranty



Model		EPC30A
Lift		Electric
Drive		Electric
Load capacity	(lb.)	5000
Load center	(in)	23.6
Wheelbase	(in)	81.89
Lowered fork height	(in)	3.35
Lifting height	(in)	7.88
Overall length	(in)	99.09
Overall width	(in)	31.81
Fork size	s/e/l (in)	1.97x7.69x45.3
Outside distance of fork	(in)	26.97
Turning radius	(in)	89.68
Lifting speed, laden/unladen	(in/s)	.90/.94
Lowering speed, laden/unladen	(in/s)	1.18/.78
Max gradient performance laden/unladen	(%)	3/6
Brake type		electromagnetic
Drive motor	(W)	1500
Lift motor	(W)	800
Charger	(V/A)	N/A
Battery voltage/rated capacity	(V/Ah)	24V/360Ah
AC Drive Motor		AC Motor
Noise level at operator seat	(dB(A))	70
Service weight (with battery)	(lb.)	2400

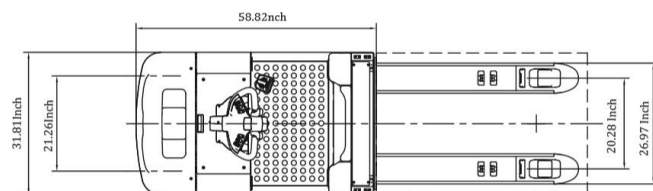
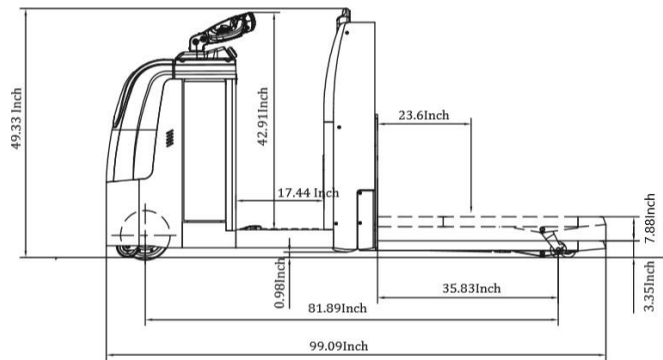

EKKO EP30A Rider Pallet Jack

The EKKO EP30A Rider Pallet Jack is designed with the versatility of a pallet jack with full power lifting and driving capabilities. It is ideal for loading and unloading trucks, loading docks, stock rooms, manufacturing floors and warehousing.

Made from high quality steel and components with durable quality drives to withstand any terrain, usage, impact and directional changes for the use of any application with confidence and assurance.

- Load Capacity 6600 lb.
- Fork Size 27x48
- Curtis Instrument Controller
- Raised Height 9.17"
- Lowered Height 3.26"
- Polyurethane Wheels
- Ergonomic Handle and Controls
- Steel Construction
- Robotic Welding
- 3 Year Limited Warranty



Model		EP30A
Lift		Electric
Drive		Electric
Load capacity	(lb.)	6600
Load center	(in)	24
Wheelbase	(in)	67.72
Lowered fork height	(in)	3.26
Lifting height	(in)	9.17
Overall length	(in)	88.58
Overall width	(in)	35.83
Fork size	s/e/l (in)	2/9/48
Outside distance of fork	in	27
Turning radius	(in)	81.34
Lifting speed, laden/unladen	(in/s)	7.5/8
Lowering speed, laden/unladen	(in/s)	36/30
Max gradient performance laden/unladen	(%)	5/15
Brake type		electromagnetic
Drive motor	(W)	3000
Lift motor	(W)	2200
Charger	(V/A)	N/A
Battery voltage/rated capacity	(V/Ah)	24V/280Ah
AC Drive Motor		AC Motor
Noise level at operator seat	(dB(A))	70
Service weight (with battery)	(lb.)	1720

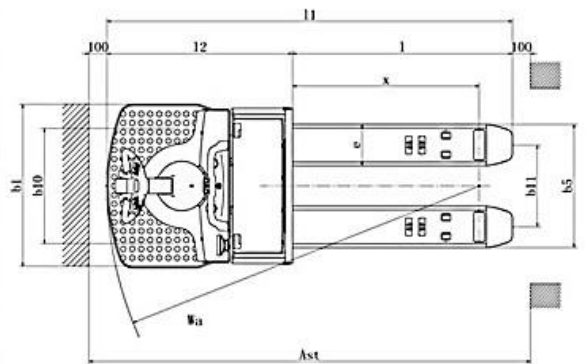
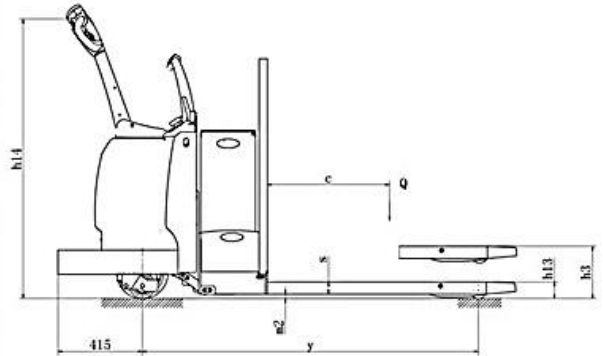

EKKO EP25E Walkie Pallet Jack

The EKKO EP25E Electric Walkie Pallet Jack is designed with the versatility of a pallet jack with full power lifting and driving capabilities. It is ideal for loading and unloading trucks, loading docks, stock rooms, manufacturing floors and warehousing.

Made from high quality steel and components with durable quality drives to withstand any terrain, usage, impact and directional changes for the use of any application with confidence and assurance.

- Load Capacity 5500 lb.
- Fork Size 27x48
- Curtis Instrument Controller
- Raised Height 7.9"
- Lowered Height 3.3"
- Polyurethane Wheels
- Ergonomic Handle and Controls
- Steel Construction
- Robotic Welding
- 3 Year Limited Warranty

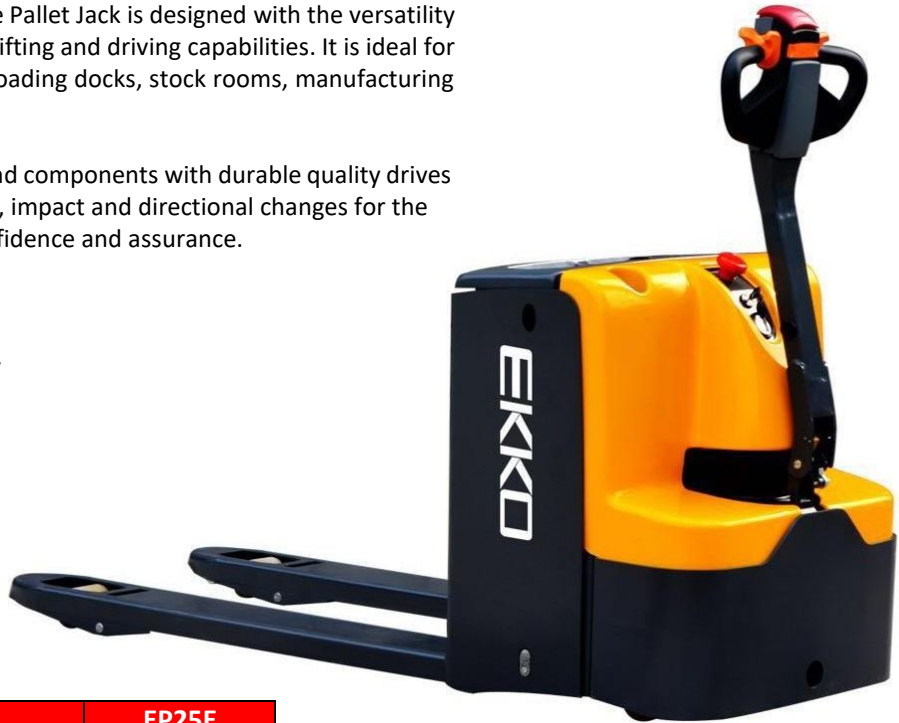

Model		EP25E
Lift		Electric
Drive		Electric
Load capacity	(lb.)	5500
Load center	(in)	24
Wheel base	(in)	53
Lowered fork height	(in)	3.33
Lifting height	(in)	7.9
Overall length	(in)	71.2
Overall width	(in)	27.5
Fork size	s/e/l (in)	2/6/48
Outside distance of fork	(in)	27
Turning radius	(in)	60
Lifting speed, laden/unladen	(in/s)	0.8/1.1
Lowering speed, laden/unladen	(in/s)	1.5/1.5
Max gradient performance laden/unladen	(%)	8/15
Brake type		electromagnetic
Drive motor	(W)	1300W
Lift motor	(W)	800W
Charger	(V/A)	24V/30A
Battery voltage/rated capacity	(V/Ah)	24V/240Ah
AC Drive Motor		AC Motor speed control
Noise level at operator seat	(dB(A))	68
Service weight (with battery)	(lb.)	1100

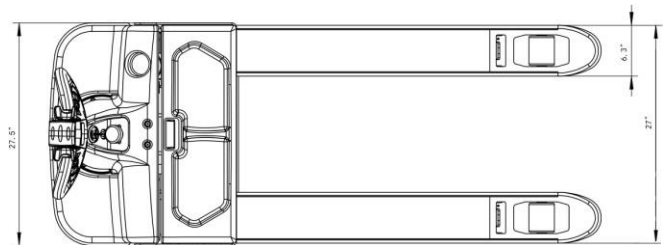
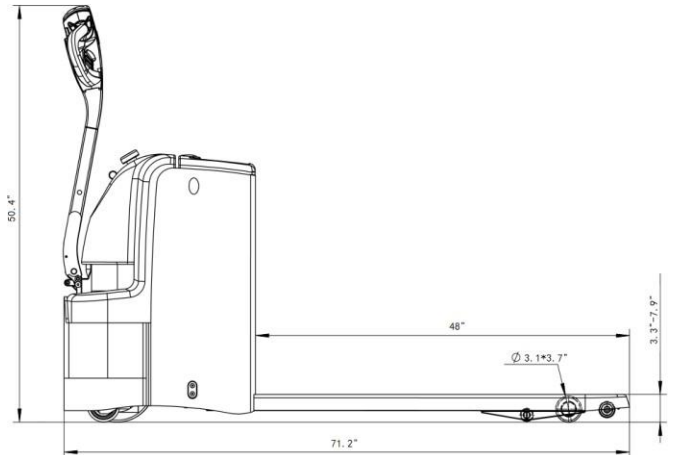

EKKO EP20E Walkie Pallet Jack

The EKKO EP20E Electric Walkie Pallet Jack is designed with the versatility of a pallet jack with full power lifting and driving capabilities. It is ideal for loading and unloading trucks, loading docks, stock rooms, manufacturing floors and warehousing.

Made from high quality steel and components with durable quality drives to withstand any terrain, usage, impact and directional changes for the use of any application with confidence and assurance.

- Load Capacity 4400 lb.
- Fork Size 27x48
- Curtis Instrument Controller
- Raised Height 7.9"
- Lowered Height 3.3"
- Polyurethane Wheels
- Ergonomic Handle and Controls
- Steel Construction
- Robotic Welding
- 3 Year Limited Warranty

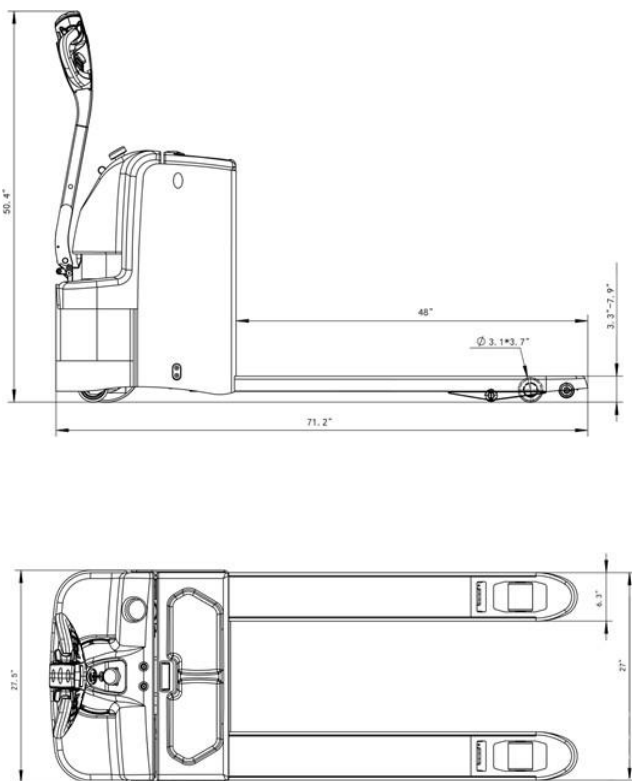

Model		EP20E
Lift		Electric
Drive		Electric
Load capacity	(lb.)	4400
Load center	(in)	24
Wheel base	(in)	53
Lowered fork height	(in)	3.3
Lifting height	(in)	7.9
Overall length	(in)	71.2
Overall width	(in)	28
Fork size	s/e/l (in)	2/6/48
Outside distance of fork	(in)	27
Turning radius	(in)	60
Lifting speed, laden/unladen	(in/s)	0.8/1.1
Lowering speed, laden/unladen	(in/s)	1.5/1.5
Max gradient performance laden/unladen	(%)	8/15
Brake type		electromagnetic
Drive motor	(W)	1300W
Lift motor	(W)	
Charger	(V/A)	24V/15A
Battery voltage/rated capacity	(V/Ah)	24V/160Ah
AC Drive Motor		AC Motor speed control
Noise level at operator seat	(dB(A))	68
Service weight with battery	(lb.)	860

EKKO EP20D Walkie Pallet Jack

The EKKO EP20D Electric Walkie Pallet Jack is designed with the versatility of a pallet jack with full power lifting and driving capabilities. It is ideal for loading and unloading trucks, loading docks, stock rooms, manufacturing floors and warehousing.

Made from high quality steel and components with durable quality drives to withstand any terrain, usage, impact and directional changes for the use of any application with confidence and assurance.

- Load Capacity 4400 lb.
- Fork Size 27x48
- Raised Height 7.7"
- Lowered Height 3.3"
- Polyurethane Wheels
- Ergonomic Handle and
- AC Drive Motor
- Controls
- Steel Construction
- Robotic Welding
- Built-in Charger
- 3 Year Limited Warranty



Model		EP20D
Lift		Electric
Drive		Electric
Load capacity	(lb.)	4400
Load center	(in)	24
Wheel base	(in)	53
Lowered fork height	(in)	3.3
Lifting height	(in)	7.7
Overall length	(in)	67.2
Overall width	(in)	27.5
Fork size	s/e/l (in)	2/6/48
Outside distance of fork	(in)	27
Turning radius	(in)	55
Lifting speed, laden/unladen	(in/s)	0.8/1.1
Lowering speed, laden/unladen	(in/s)	1.5/1.5
Max gradient performance laden/unladen	(%)	8/15
Brake type		electromagnetic
AC Drive motor	(W)	750W
Lift motor	(W)	800W
Battery voltage/rated capacity	(V/Ah)	24V/100Ah
DC Drive Motor		AC Motor speed control
Noise level at operator seat	(dB(A))	68
Service weight with battery	(lb.)	745

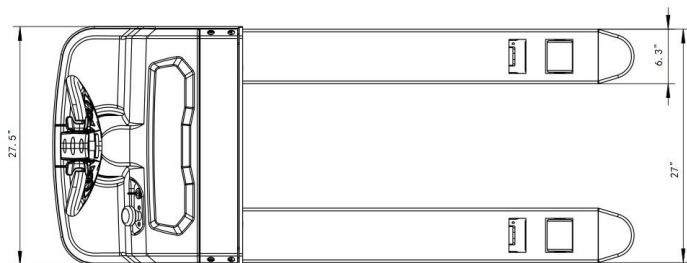
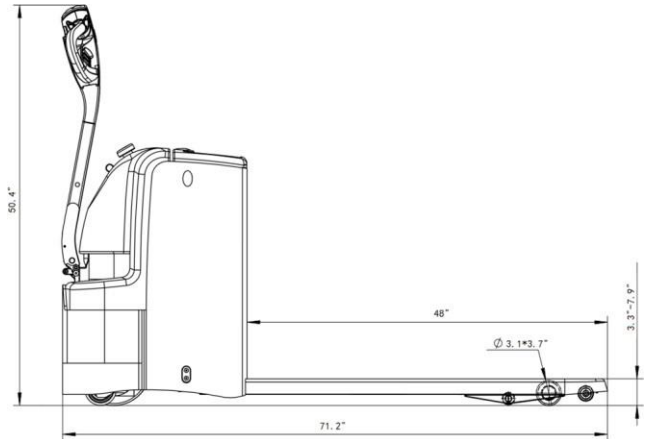

EKKO EP18D Walkie Pallet Jack

The EKKO EP18D Electric Walkie Pallet Jack is designed with the versatility of a pallet jack with full power lifting and driving capabilities. It is ideal for loading and unloading trucks, loading docks, stock rooms, manufacturing floors and warehousing.

Made from high quality steel and components with durable quality drives to withstand any terrain, usage, impact and directional changes for the use of any application with confidence and assurance.

- Load Capacity 4000 lb.
- Fork Size 27x48
- Raised Height 7.7"
- Lowered Height 3.3"
- Polyurethane Wheels
- Ergonomic Handle and Controls
- Steel Construction
- Robotic Welding
- Built-in Charger
- 3 Year Limited Warranty



Model		EP18D
Lift		Electric
Drive		Electric
Load capacity	(lb.)	4000
Load center	(in)	24
Wheel base	(in)	53
Lowered fork height	(in)	3.3
Lifting height	(in)	7.7
Overall length	(in)	67.2
Overall width	(in)	27.5
Fork size	s/e/l (in)	2/6/48
Outside distance of fork	(in)	27
Turning radius	(in)	55
Lifting speed, laden/unladen	(in/s)	0.8/1.1
Lowering speed, laden/unladen	(in/s)	1.5/1.5
Max gradient performance laden/unladen	(%)	8/15
Brake type		electromagnetic
Drive motor	(W)	750W
Lift motor	(W)	80W
Battery voltage/rated capacity	(V/Ah)	24V/80Ah
DC Drive Motor		DC Motor speed control
Noise level at operator seat	(dB(A))	68
Service Weight (with battery)	(lb.)	720

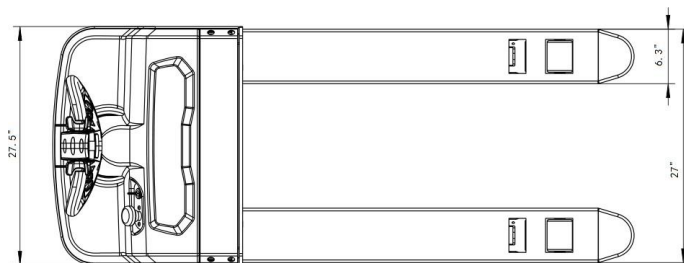
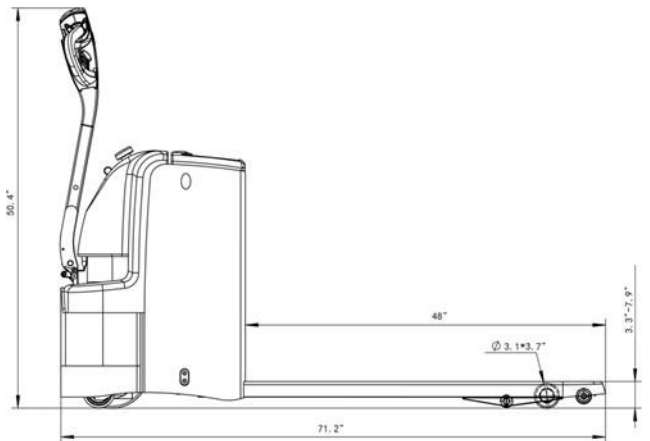

EKKO EP20LI LITHIUM-IRON Walkie Pallet Jack

The EKKO EP20LI LITHIUM-IRON Phosphate Electric Walkie Pallet Jack is designed with the versatility of a pallet jack with full power lifting and driving capabilities. It is ideal for loading and unloading trucks, loading docks, stock rooms, manufacturing floors and warehousing.

Made from high quality steel and components with durable quality drives to withstand any terrain, usage, impact and directional changes for the use of any application with confidence and assurance.

- Load Capacity 4400 lb.
- Fork Size 27x48
- Raised Height 7.7"
- Lowered Height 3.3"
- Polyurethane Wheels
- Ergonomic Handle and Controls
- Steel Construction
- Robotic Welding
- Built-in Charger
- 3 Year Limited Warranty

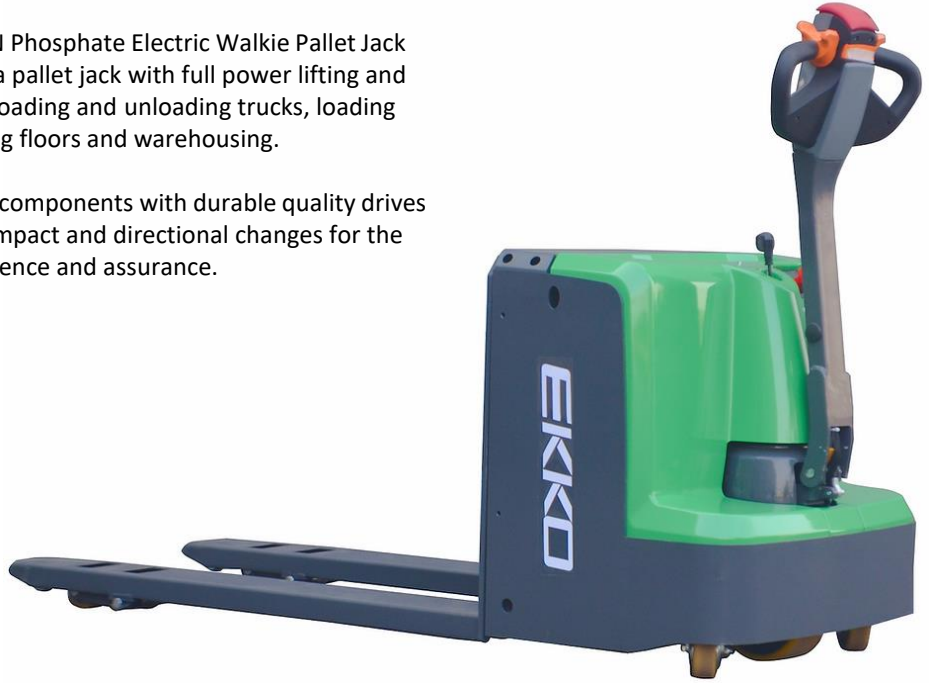

Model		EP20LI
Lift		Electric
Drive		Electric
Load capacity	(lb.)	4400
Load center	(in)	24
Wheel base	(in)	53
Lowered fork height	(in)	3.3
Lifting height	(in)	7.7
Overall length	(in)	67.2
Overall width	(in)	27.5
Fork size	s/e/l (in)	2/6/48
Outside distance of fork	(in)	27
Turning radius	(in)	55
Lifting speed, laden/unladen	(in/s)	0.8/1.1
Lowering speed, laden/unladen	(in/s)	1.5/1.5
Max gradient performance laden/unladen	(%)	8/15
Brake type		electromagnetic
Drive motor	(W)	750W
Lift motor	(W)	80WLITHIUM
Lithium-iron Battery voltage/rated capacity	(V/Ah)	24V/60Ah Li
DC Drive Motor		DC Motor speed control
Noise level at operator seat	(dB(A))	68
Service weigh (with battery)	(lb.)	680

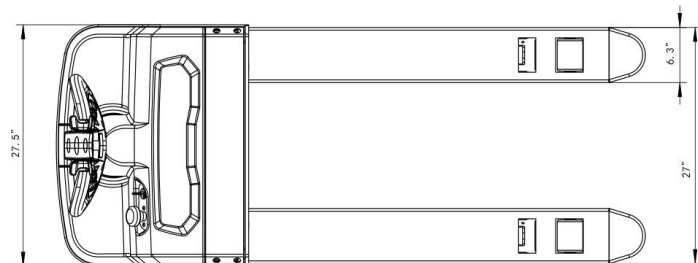
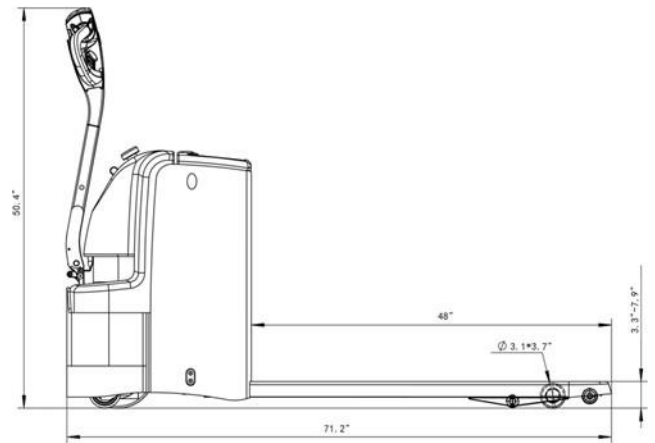

EKKO EP18LI LITHIUM-IRON Walkie Pallet Jack

The EKKO EP18LI Lithium Iron Phosphate Electric Walkie Pallet Jack is designed with the versatility of a pallet jack with full power lifting and driving capabilities. It is ideal for loading and unloading trucks, loading docks, stock rooms, manufacturing floors and warehousing.

Made from high quality steel and components with durable quality drives to withstand any terrain, usage, impact and directional changes for the use of any application with confidence and assurance.

- Load Capacity 4000 lb.
- Fork Size 27x48
- Raised Height 7.7"
- Lowered Height 3.3"
- Polyurethane Wheels
- Ergonomic Handle and Controls
- Steel Construction
- Robotic Welding
- Built-in Charger
- 3 Year Limited Warranty



Model		EP18LI
Lift		Electric
Drive		Electric
Load capacity	(lb.)	4000
Load center	(in)	24
Wheel base	(in)	53
Lowered fork height	(in)	3.3
Lifting height	(in)	7.7
Overall length	(in)	67.2
Overall width	(in)	27.5
Fork size	s/e/l (in)	2/6/48
Outside distance of fork	(in)	27
Turning radius	(in)	55
Lifting speed, laden/unladen	(in/s)	0.8/1.1
Lowering speed, laden/unladen	(in/s)	1.5/1.5
Max gradient performance laden/unladen	(%)	8/15
Brake type		electromagnetic
Drive motor	(W)	750W
Lift motor	(W)	80WLITHIUM
Lithium-Iron Battery voltage/rated capacity	(V/Ah)	24V/40Ah Li
DC Drive Motor		DC Motor speed control
Noise level at operator seat	(dB(A))	68
Service weight (with battery)	(lb.)	650

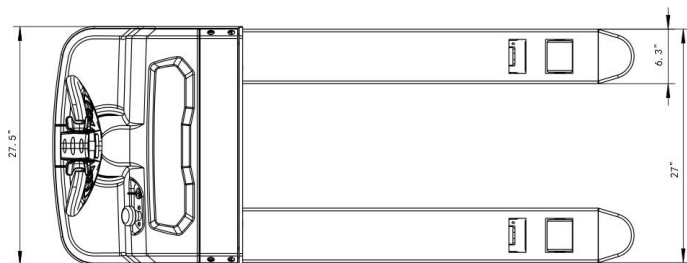
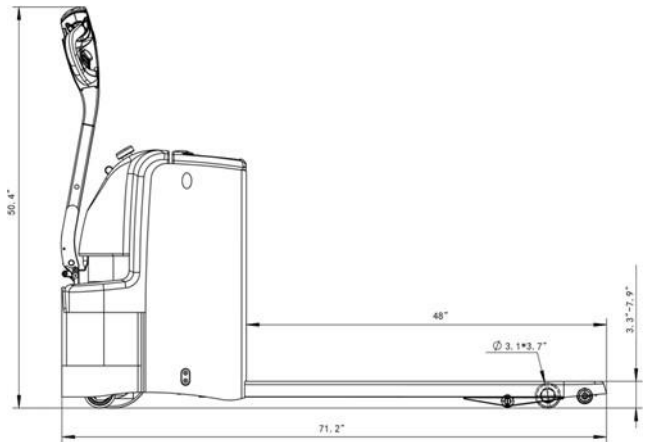

EKKO EPE20LI LITHIUM-IRON Walkie Pallet Jack

The EKKO EPE20LI Lithium-Iron Phosphate Electric Walkie Pallet Jack is designed with the versatility of a pallet jack with full power lifting and driving capabilities. It is ideal for loading and unloading trucks, loading docks, stock rooms, manufacturing floors and warehousing.

Made from high quality steel and components with durable quality drives to withstand any terrain, usage, impact and directional changes for the use of any application with confidence and assurance.

- Load Capacity 4400 lb.
- Fork Size 27x48
- Raised Height 7.87"
- 48V/30Ah Li-Iron LiFePO4
- Pin Code Panel
- Pinwheel Capability
- Lowered Height 2.95"
- Polyurethane Wheels
- Ergonomic Handle and Controls
- Steel Construction
- Robotic Welding
- 3 Year Limited Warranty



Model		EPE20LI
Lift		Electric
Drive		Electric
Load capacity	(lb.)	4400
Load center	(in)	23.6
Wheelbase	(in)	51.69
Lowered fork height	(in)	2.95
Lifting height	(in)	7.87
Overall length	(in)	65.86
Overall width	(in)	26.97
Fork size	s/e/l (in)	1.97/5.9/48.03
Outside distance of fork	(in)	26.97
Turning radius	(in)	57.8
Lifting speed, laden/unladen	(in/s)	N/A
Lowering speed, laden/unladen	(in/s)	N/A
Max gradient performance laden/unladen	(%)	5/8
Brake type		electromagnetic
Drive motor	(W)	750W
Lift motor	(W)	800W
Battery voltage/rated capacity	(V/Ah)	48V/30Ah Li
DC Drive Motor		DC Motor speed control
Noise level at operator seat	(dB(A))	70
Service weight with battery	(lb.)	390

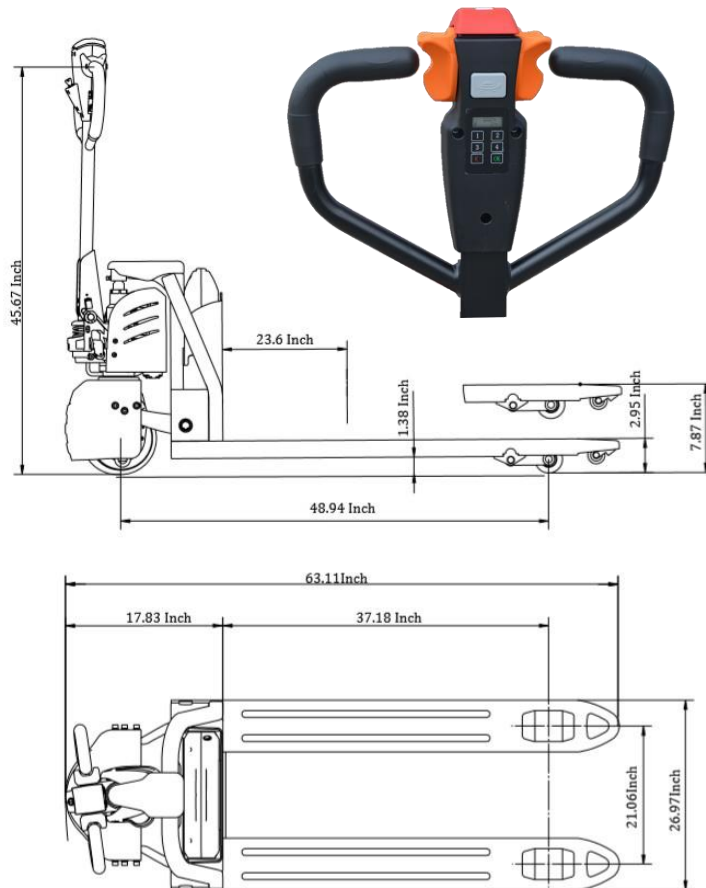

EKKO EPE18LI LITHIUM-IRON Walkie Pallet Jack

The EKKO EPE18LI Lithium-Iron Phosphate Electric Walkie Pallet Jack is designed with the versatility of a pallet jack with full power lifting and driving capabilities. It is ideal for loading and unloading trucks, loading docks, stock rooms, manufacturing floors and warehousing.

Made from high quality steel and components with durable quality drives to withstand any terrain, usage, impact and directional changes for the use of any application with confidence and assurance.

- Load Capacity 4000 lb.
- Fork Size 27x48
- Raised Height 7.87"
- 24V/40Ah Li-Iron LiFePO4
- Pin Code Panel
- Pinwheel Capability
- Lowered Height 2.95"
- Polyurethane Wheels
- Ergonomic Handle and Controls
- Steel Construction
- Robotic Welding
- 3 Year Limited Warranty



Model		EPE18LI
Lift		Electric
Drive		Electric
Load capacity	(lb.)	4000
Load center	(in)	23.6
Wheelbase	(in)	51.69
Lowered fork height	(in)	2.95
Lifting height	(in)	7.87
Overall length	(in)	65.86
Overall width	(in)	26.97
Fork size	s/e/l (in)	1.97/5.9/48.03
Outside distance of fork	(in)	26.97
Turning radius	(in)	57.8
Lifting speed, laden/unladen	(in/s)	N/A
Lowering speed, laden/unladen	(in/s)	N/A
Max gradient performance laden/unladen	(%)	5/8
Brake type		electromagnetic
Drive motor	(W)	750W
Lift motor	(W)	800W
Battery voltage/rated capacity	(V/Ah)	24V/40Ah Li
DC Drive Motor		DC Motor speed control
Noise level at operator seat	(dB(A))	70
Service weight with battery	(lb.)	370

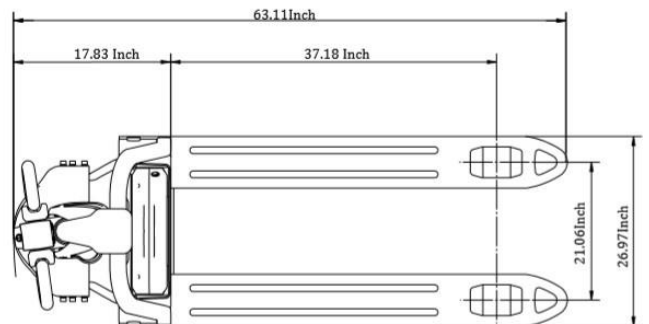
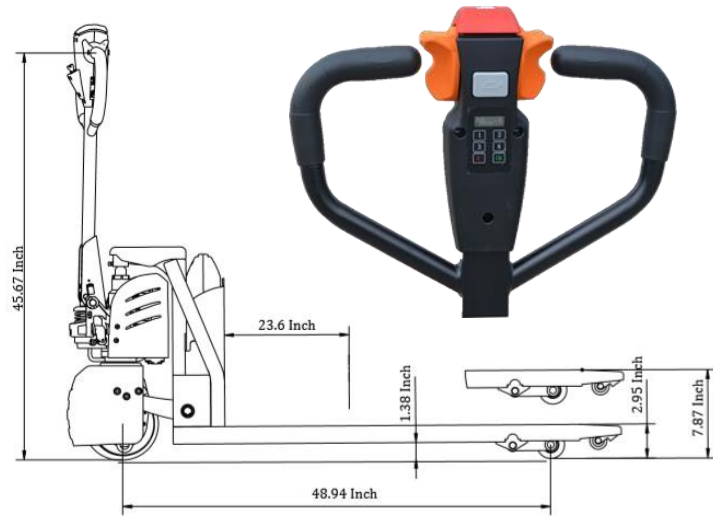

EKKO EPE15LI LITHIUM-IRON Walkie Pallet Jack

The EKKO EPE15LI Lithium-Iron Phosphate Electric Walkie Pallet Jack is designed with the versatility of a pallet jack with full power lifting and driving capabilities. It is ideal for loading and unloading trucks, loading docks, stock rooms, manufacturing floors and warehousing.

Made from high quality steel and components with durable quality drives to withstand any terrain, usage, impact and directional changes for the use of any application with confidence and assurance.

- Load Capacity 3300 lb.
- Fork Size 27x48
- Raised Height 7.87"
- 24V/30Ah Li-Iron LiFePO4
- Pin Code Panel
- Pinwheel Capability
- Lowered Height 2.95"
- Polyurethane Wheels
- Ergonomic Handle and Controls
- Steel Construction
- Robotic Welding
- 3 Year Limited Warranty



Model		EPE15LI
Lift		Electric
Drive		Electric
Load capacity	(lb.)	3300
Load center	(in)	23.6
Wheelbase	(in)	51.69
Lowered fork height	(in)	2.95
Lifting height	(in)	7.87
Overall length	(in)	65.86
Overall width	(in)	26.97
Fork size	s/e/l (in)	1.97/5.9/48.03
Outside distance of fork	(in)	26.97
Turning radius	(in)	57.8
Lifting speed, laden/unladen	(in/s)	N/A
Lowering speed, laden/unladen	(in/s)	N/A
Max gradient performance laden/unladen	(%)	5/8
Brake type		electromagnetic
Drive motor	(W)	750W
Lift motor	(W)	800W
Battery voltage/rated capacity	(V/Ah)	24V/30Ah Li
DC Drive Motor		DC Motor speed control
Noise level at operator seat	(dB(A))	70
Service weight with battery	(lb.)	345

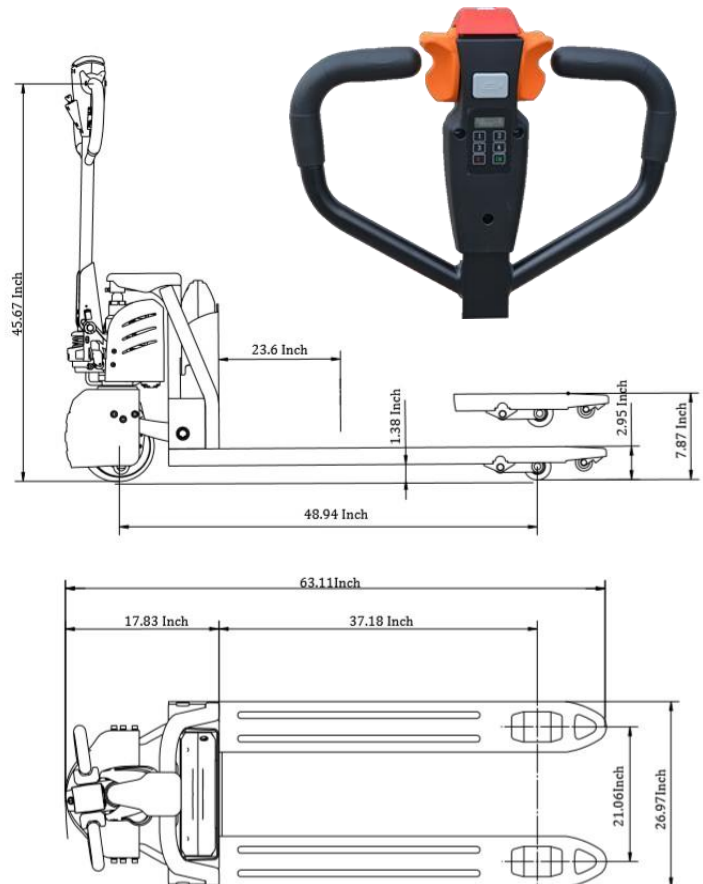

EKKO EP18SLI LITHIUM-IRON Walkie Pallet Jack

The EKKO EP18SLI Lithium-Iron Phosphate Electric Walkie Pallet Jack is designed with the versatility of a pallet jack with full power lifting and driving capabilities. It is ideal for loading and unloading trucks, loading docks, stock rooms, manufacturing floors and warehousing.

Made from high quality steel and components with durable quality drives to withstand any terrain, usage, impact and directional changes for the use of any application with confidence and assurance.

- Load Capacity 4000 lb.
- Fork Size 27x48
- Raised Height 7.87"
- Pinwheel Capability
- 24V/40Ah Li-Iron LiFePO4
- Lowered Height 2.95"
- Polyurethane Wheels
- Ergonomic Handle and Controls
- Steel Construction
- Robotic Welding
- 3 Year Limited Warranty



Model		EP18SLI
Lift		Electric
Drive		Electric
Load capacity	(lb.)	4000
Load center	(in)	23.6
Wheelbase	(in)	51.69
Lowered fork height	(in)	3.35
Lifting height	(in)	7.87
Overall length	(in)	65.86
Overall width	(in)	26.97
Fork size	s/e/l (in)	1.97/5.9/48.03
Outside distance of fork	(in)	26.97
Turning radius	(in)	57.8
Lifting speed, laden/unladen	(in/s)	N/A
Lowering speed, laden/unladen	(in/s)	N/A
Max gradient performance laden/unladen	(%)	5/8
Brake type		electromagnetic
Drive motor	(W)	750W
Lift motor	(W)	800W
Battery voltage/rated capacity	(V/Ah)	24V/40Ah Li
DC Drive Motor		DC Motor speed control
Noise level at operator seat	(dB(A))	70
Service weight with battery	(lb.)	345

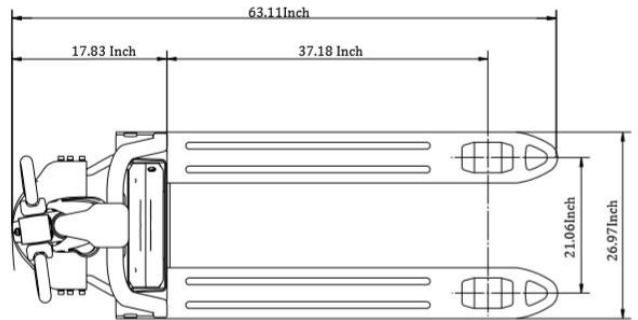
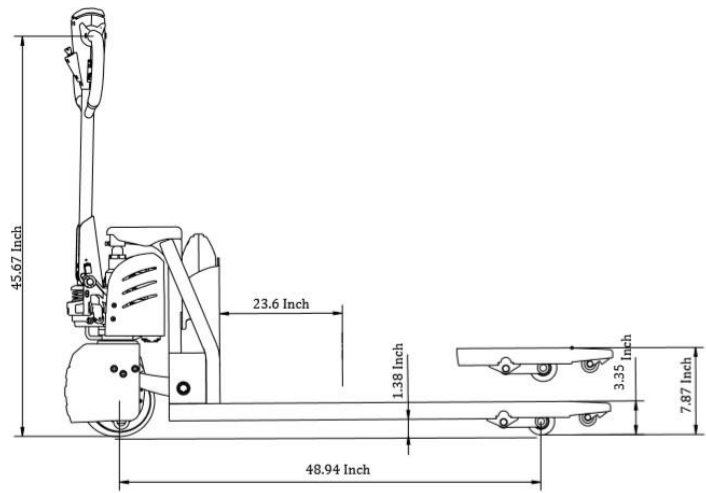

EKKO EP15SLI LITHIUM-IRON Walkie Pallet Jack

The EKKO EP15SLI Lithium-Iron Phosphate Electric Walkie Pallet Jack is designed with the versatility of a pallet jack with full power lifting and driving capabilities. It is ideal for loading and unloading trucks, loading docks, stock rooms, manufacturing floors and warehousing.

Made from high quality steel and components with durable quality drives to withstand any terrain, usage, impact and directional changes for the use of any application with confidence and assurance.

- Load Capacity 3300 lb.
- Fork Size 27x48
- Raised Height 7.87"
- 24V/30Ah Li-Iron LiFePO4
- Pinwheel Capability
- Lowered Height 2.95"
- Polyurethane Wheels
- Ergonomic Handle and Controls
- Steel Construction
- Robotic Welding
- 3 Year Limited Warranty

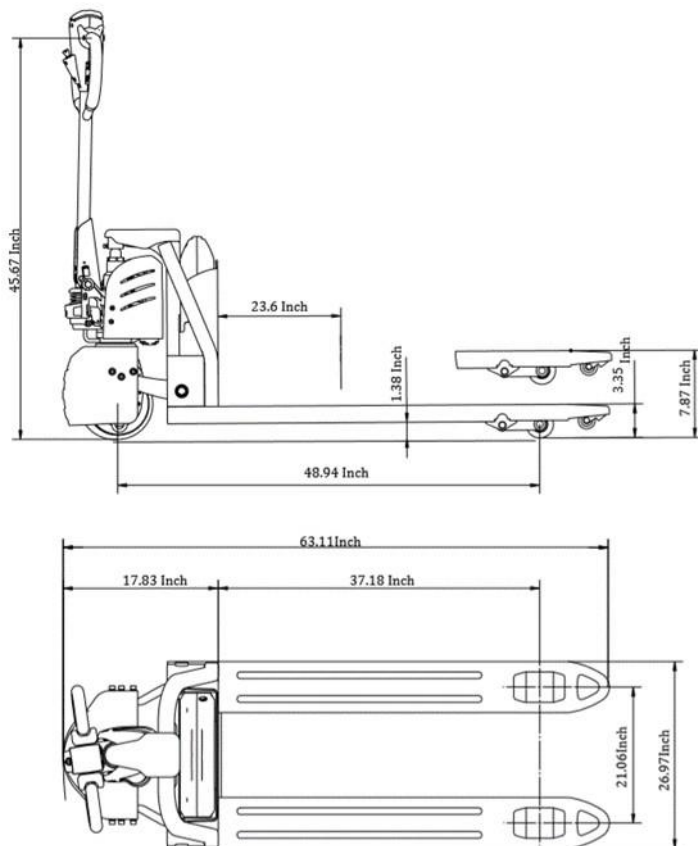

Model		EP15SLI
Lift		Electric
Drive		Electric
Load capacity	(lb.)	3300
Load center	(in)	23.6
Wheelbase	(in)	51.69
Lowered fork height	(in)	3.35
Lifting height	(in)	7.87
Overall length	(in)	65.86
Overall width	(in)	26.97
Fork size	s/e/l (in)	1.97/5.9/48.03
Outside distance of fork	(in)	26.97
Turning radius	(in)	57.8
Lifting speed, laden/unladen	(in/s)	N/A
Lowering speed, laden/unladen	(in/s)	N/A
Max gradient performance laden/unladen	(%)	5/8
Brake type		electromagnetic
Drive motor	(W)	750W
Lift motor	(W)	800W
Battery voltage/rated capacity	(V/Ah)	24V/30Ah Li
DC Drive Motor		DC Motor speed control
Noise level at operator seat	(dB(A))	70
Service weight with battery	(lb.)	345

EKKO EP15LI LITHIUM-IRON Walkie Pallet Jack

The EKKO EP15LI Lithium-Iron Phosphate Electric Walkie Pallet Jack is designed with the versatility of a pallet jack with full power lifting and driving capabilities. It is ideal for loading and unloading trucks, loading docks, stock rooms, manufacturing floors and warehousing.

Made from high quality steel and components with durable quality drives to withstand any terrain, usage, impact and directional changes for the use of any application with confidence and assurance.

- Load Capacity 3300 lb.
- Fork Size 27x48
- Raised Height 7.87"
- 24V/35Ah Li-Iron LiFePO4
- On-Board Charger
- Lowered Height 3.35"
- Polyurethane Wheels
- Ergonomic Handle and Controls
- Steel Construction
- Robotic Welding
- 3 Year Limited Warranty



Model		EP15LI
Lift		Electric
Drive		Electric
Load capacity	(lb.)	3300
Load center	(in)	23.62
Wheel base	(in)	51.69
Lowered fork height	(in)	3.35
Lifting height	(in)	7.87
Overall length	(in)	66.34
Overall width	(in)	26.97
Fork size	s/e/l (in)	1.97/5.9/48.03
Outside distance of fork	(in)	26.97
Turning radius	(in)	58
Lifting speed, laden/unladen	(in/s)	N/A
Lowering speed, laden/unladen	(in/s)	N/A
Max gradient performance laden/unladen	(%)	5/8
Brake type		electromagnetic
Drive motor	(W)	750W
Lift motor	(W)	800W
Battery voltage/rated capacity	(V/Ah)	24V/35Ah Li
DC Drive Motor		DC Motor speed control
Noise level at operator seat	(dB(A))	70
Service weight with battery	(lb.)	352

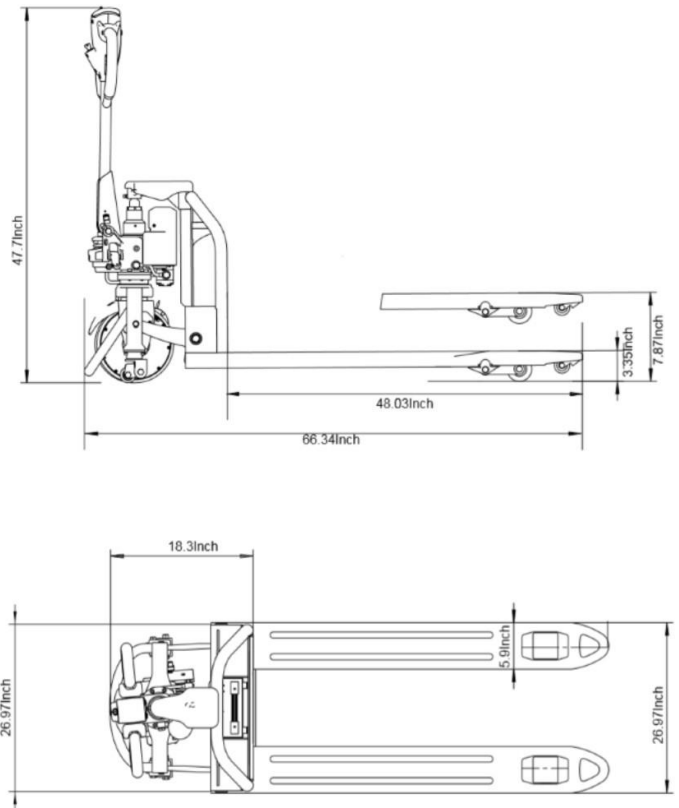

EKKO EP15JLI LITHIUM-IRON Walkie Pallet Jack

The EKKO EP-JLI series Lithium Iron Phosphate Electric Walkie Pallet Jacks are designed with the versatility of a pallet jack with full power lifting and driving capabilities. It is ideal for loading and unloading trucks, loading docks, stock rooms, manufacturing floors and warehousing.

Made from high quality steel and components with durable quality drives to withstand any terrain, usage, impact and directional changes for the use of any application with confidence and assurance.

- Lithium 24V Powered
- Load Capacity 3300 lb.
- Fork Size 27x48
- Raised Height 7.87"
- Lowered Height 3.35"
- Pinwheel Capability
- Polyurethane Wheels
- Ergonomic Handle and Controls
- Steel Construction
- Robotic Welding
- Charger Included
- (1) Lithium Iron LiFePO4 Battery
- 3 Years Limited Warranty



Model		EP15JLI
Lift		Electric
Drive		Electric
Load capacity	(lb.)	3300
Load center	(in)	23.6
Wheel base	(in)	47.6
Lowered fork height	(in)	3.35
Lifting height	(in)	7.8
Overall length	(in)	61.81
Overall width	(in)	27
Fork size	s/e/l (in)	1.97/5.9/48
Fork Width	(in)	61.81
Turning radius	(in)	53.7
Lifting speed, laden/unladen	(in/s)	N/A
Lowering speed, laden/unladen	(in/s)	N/A
Max gradient performance laden/unladen	(%)	5/10
Brake type		electromagnetic
Drive motor	(KW)	0.75
Lift motor	(KW)	0.8
Battery voltage/rated capacity	(V/Ah)	24V/30Ah Li
DC Drive Motor		DC Motor speed control
Noise level at operator seat	(dB(A))	70
Service weight with battery	(lb.)	308

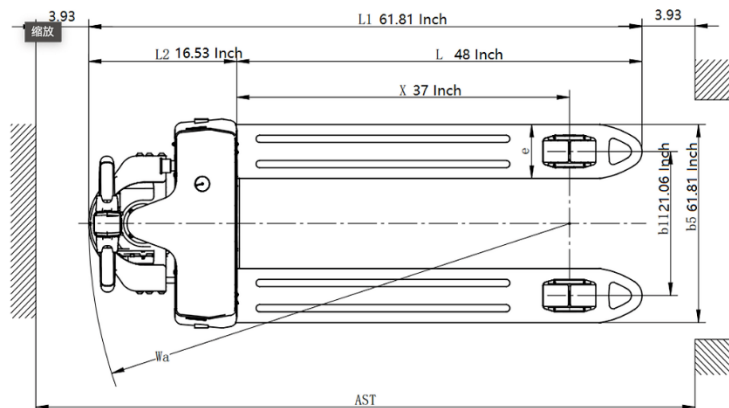
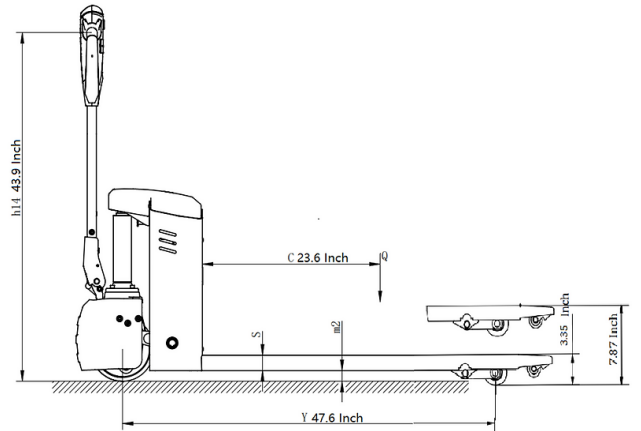

EKKO EP18JLI LITHIUM-IRON Walkie Pallet Jack

The EKKO EP18JLI Lithium Iron Phosphate Electric Walkie Pallet Jack is designed with the versatility of a pallet jack with full power lifting and driving capabilities. It is ideal for loading and unloading trucks, loading docks, stock rooms, manufacturing floors and warehousing.

Made from high quality steel and components with durable quality drives to withstand any terrain, usage, impact and directional changes for the use of any application with confidence and assurance.

- Lithium 24V Powered
- Load Capacity 4000 lb.
- Fork Size 27x48
- Raised Height 7.8"
- Lowered Height 3.35"
- Pinwheel Capability
- Polyurethane Wheels
- Ergonomic Handle and Controls
- Steel Construction
- Robotic Welding
- Charger Included
- (1) Lithium Iron Battery LiFePO4 Included 24V/40Ah
- 3 Years Limited Warranty



Model		EP18JLI
Lift		Electric
Drive		Electric
Load capacity	(lb.)	4000
Load center	(in)	23.6
Wheel base	(in)	47.6
Lowered fork height	(in)	3.35
Lifting height	(in)	7.8
Overall length	(in)	61.81
Overall width	(in)	27
Fork size	s/e/l (in)	1.97/5.9/48
Fork Width	(in)	61.81
Turning radius	(in)	53.7
Lifting speed, laden/unladen	(in/s)	N/A
Lowering speed, laden/unladen	(in/s)	N/A
Max gradient performance laden/unladen	(%)	5/10
Brake type		electromagnetic
Drive motor	(KW)	0.75
Lift motor	(KW)	0.8
Battery voltage/rated capacity	(V/Ah)	24V/40Ah Li
DC Drive Motor		DC Motor speed control
Noise level at operator seat	(dB(A))	70
Service weight with battery	(lb.)	319

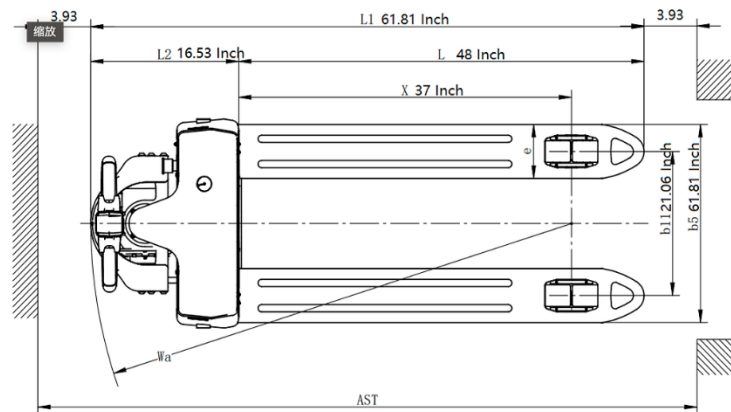
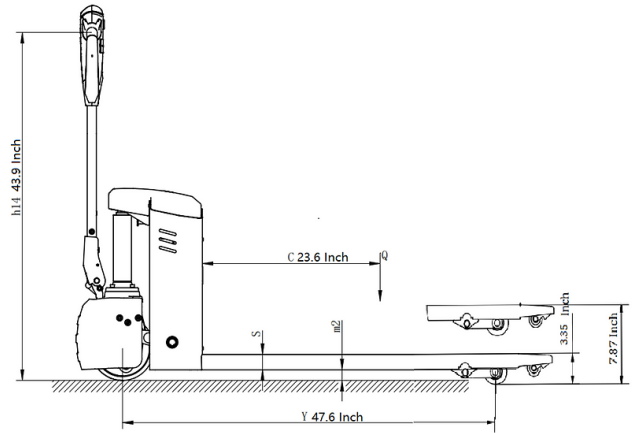

EKKO EP20JLI LITHIUM-IRON Walkie Pallet Jack

The EKKO EP20JLI Lithium Iron Phosphate Electric Walkie Pallet Jack is designed with the versatility of a pallet jack with full power lifting and driving capabilities. It is ideal for loading and unloading trucks, loading docks, stock rooms, manufacturing floors and warehousing.

Made from high quality steel and components with durable quality drives to withstand any terrain, usage, impact and directional changes for the use of any application with confidence and assurance.

- Lithium 48V Powered
- Load Capacity 4400 lb.
- Fork Size 27x48
- Raised Height 7.8"
- Lowered Height 3.35"
- Pinwheel Capability
- Polyurethane Wheels
- Ergonomic Handle and Controls
- Steel Construction
- Robotic Welding
- Charger Included
- (1) Lithium Iron Battery LiFePO4 Included 48V/20Ah
- 3 Years Limited Warranty



Model		EP20JLI
Lift		Electric
Drive		Electric
Load capacity	(lb.)	4400
Load center	(in)	23.6
Wheel base	(in)	47.6
Lowered fork height	(in)	3.35
Lifting height	(in)	7.8
Overall length	(in)	61.81
Overall width	(in)	27
Fork size	s/e/l (in)	1.97/5.9/48
Fork Width	(in)	61.81
Turning radius	(in)	53.7
Lifting speed, laden/unladen	(in/s)	N/A
Lowering speed, laden/unladen	(in/s)	N/A
Max gradient performance laden/unladen	(%)	5/10
Brake type		electromagnetic
Drive motor	(KW)	1
Lift motor	(KW)	0.8
Battery voltage/rated capacity	(V/Ah)	48V/20Ah Li
DC Drive Motor		DC Motor speed control
Noise level at operator seat	(dB(A))	70
Service weight with battery	(lb.)	326

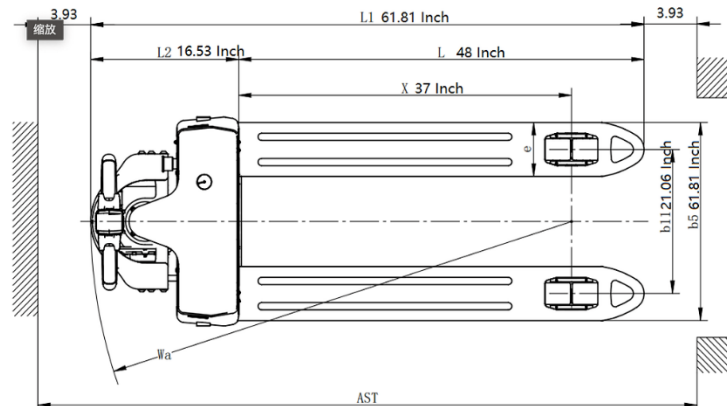
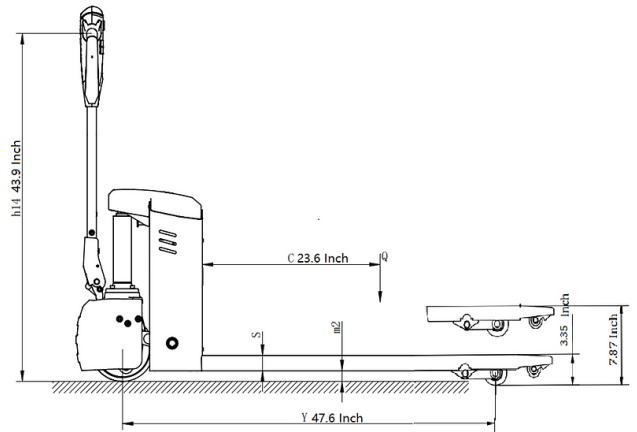

EKKO A25S Stainless Steel Manual Pallet Jack



The EKKO A25S Stainless Steel Manual Pallet Jack is designed with quality materials, components and workmanship. Every product is robotically welded and is reliable for loading and unloading trucks, loading docks, stock rooms, manufacturing floors and warehousing.

The Specialized Pallet Truck is ideal for sanitary, pharmaceutical, medical, food, and wet environments. Pallet Truck is one-hundred percent (100%) type 304 stainless steel for long life in the harshest environments.

Made from high quality stainless steel and components with durable hydraulic pumps with quality load wheels to withstand any terrain, usage, impact and directional changes for the use of any application with confidence and assurance.

- Stainless Steel
- Load Capacity 5500 lb.
- Fork Size 27x48
- Raised Height 7.5"
- Lowered Height 2.95"
- Galvanized Hydraulic Pumps
- Nylon Wheels
- Ergonomic Handles
- Steel Construction
- Robotic Welding
- 3 years limited Warranty

Model		A25S
Load Capacity	(lb.)	5500
Lifting height Max.	(in)	7.5
Fork length	(in)	48
Fork width	(in)	27
Fixed leg width, single	(in)	6.3
Overall length	(in)	63"
Overall width max	(in)	27
Lowered fork height	(in)	2.95
Service Weight	(lb.)	155

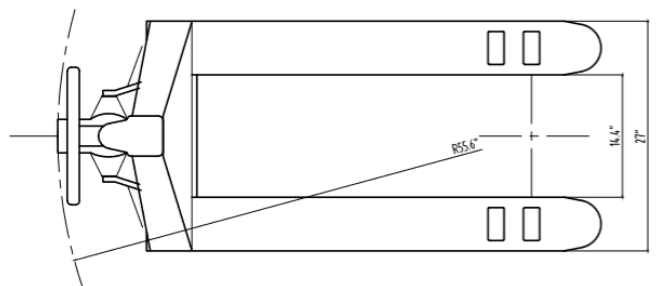
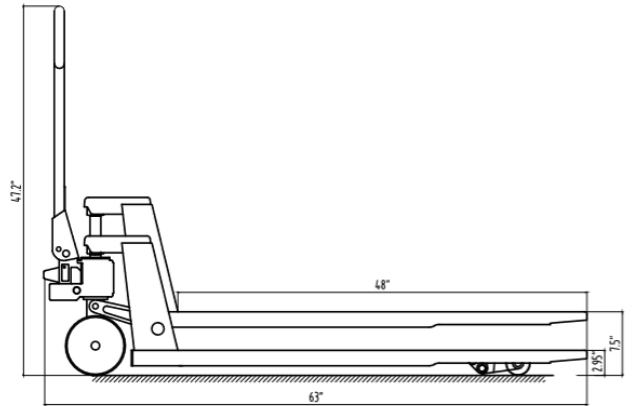

EKKO A25 Manual Pallet Jack



The EKKO A25 Manual Pallet Jack is designed with quality materials, components and workmanship. Every product is robotically welded, powder coated and is reliable for loading and unloading trucks, loading docks, stock rooms, manufacturing floors and warehousing.

Made from high quality steel and components with durable hydraulic pumps with quality load wheels to withstand any terrain, usage, impact and directional changes for the use of any application with confidence and assurance.

- Load Capacity 5500 lb.
- Fork Size 27x48
- Raised Height 7.5"
- Lowered Height 2.95"
- Galvanized Hydraulic Pumps
- Polyurethane Wheels
- Ergonomic Handles
- Powder Coated
- Steel Construction
- Robotic Welding
- 3 Year Limited Warranty

Model		A25
Load Capacity	(lb.)	5500
Lifting height Max.	(in)	7.5
Fork length	(in)	48
Fork width	(in)	27
Fixed leg width, single	(in)	6.3
Overall length	(in)	63"
Overall width max	(in)	27
Lowered fork height	(in)	2.95
Service Weight	(lb.)	160

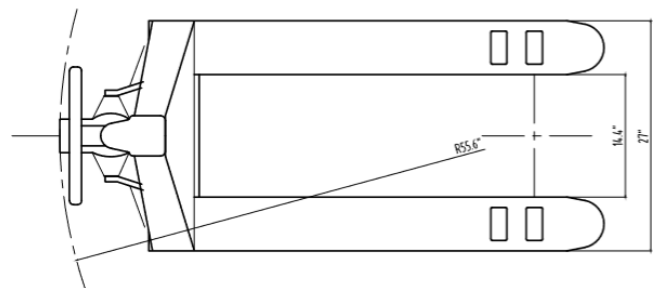
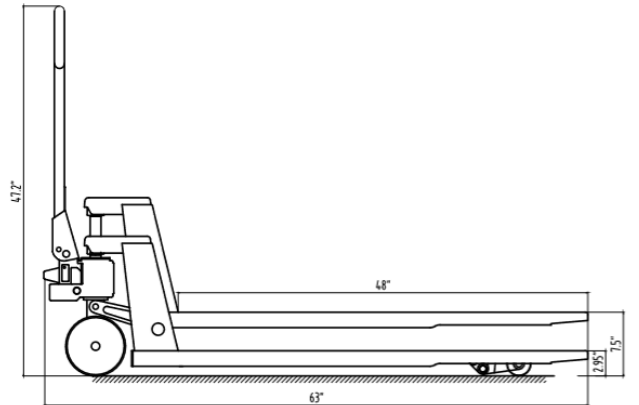

EKKO T15 Scissor Lift Table Cart

The EKKO T15 Scissor Lift Table Cart is a compact cart to make lifting, transporting loads, order-picking, and moving products with ease. An ergonomic solution to lifting, positioning and transporting goods.

Our scissor carts are made of heavy duty steel and constructed to hold up for longevity. Two polyurethane front casters and two rear swivel casters with built-in hand release and foot pump.

- Load Capacity 330 lb.
- Raised Height 28.3"
- Lowered Height 8.3"
- Size Length 27.5" x Width 17.7"
- Polyurethane Casters
- Hand Release
- Foot Brake
- Steel construction
- Robotic Welding
- 3 Years Limited Warranty



Model		T15
Load Capacity	(lb.)	330
Lifting height Max.	(in)	28.3
Length	(in)	27.5
Width	(in)	17.1
Lowest height	(in)	8.3
Handle height	(in)	31.89
Service Weight	(lb.)	88

EKKO T50 Heavy Duty Scissor Lift Table Cart

The EKKO T50 Heavy Duty Scissor Lift Table Cart is a compact cart to make lifting, transporting loads, order-picking, and moving products with ease. An ergonomic solution to lifting, positioning and transporting goods.

Our scissor carts are made of heavy duty steel and constructed to hold up for longevity. Two polyurethane front casters and two rear swivel casters with built-in hand release and foot pump.



- Load Capacity 1100lbs
- Raised Height 35.4"
- Lowered Height 11"
- Size Length 32.1" x Width 19.7"
- Polyurethane Casters
- Hand release
- Foot Brake
- Caster Guards
- Steel construction
- Robotic Welding
- 3 Years Limited Warranty

Model		T50
Load Capacity	(lb.)	1100
Lifting height Max.	(in)	35.4
Length	(in)	32.1
Width	(in)	19.7
Lowest height	(in)	11
Handle height	(in)	31.89
Service Weight	(lb.)	180

EKKO T35 Dual Scissor Lift Table Cart

The EKKO T35 Dual Scissor Lift Table Cart is a compact cart to make lifting, transporting loads, order-picking, and moving products with ease. An ergonomic solution to lifting, positioning and transporting goods.

Our scissor carts are made of heavy duty steel and constructed to hold up for longevity. Two polyurethane front casters and two rear swivel casters with built-in hand release and foot pump.

- Load Capacity 770 lb.
- Raised Height 51.2"
- Lowered Height 14"
- Size Length 35.6" x Width 19.7"
- Polyurethane Casters
- Hand Release
- Foot Brake
- Caster Guards
- Steel construction
- Robotic Welding
- 3 Years Limited Warranty



Model		T35
Load Capacity	(lb.)	770
Lifting height Max.	(in)	51.2
Length	(in)	35.6
Width	(in)	19.7
Lowest height	(in)	14
Handle height	(in)	38.2
Service Weight	(lb.)	234

EKKO ES40E Scissor Lift Aerial Platform

The EKKO ES40E Scissor Aerial Work Platform is a 506-lb capacity compact platform with four wheels and Curtis controller which allows you to make lifting, transporting loads, and moving products easily and safely. This product also complies with GB25849 and EN280 standards

- Load Capacity 500 lb.
- Raised Height 13.1' (157.5")
- Lowered Height 77"
- Size: Length 50.4" x Width 29.1"
- Steel construction
- 3 Years Limited Warranty

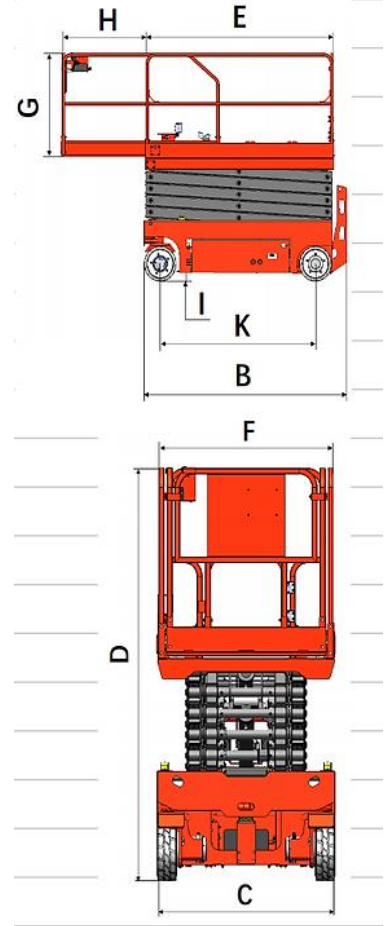
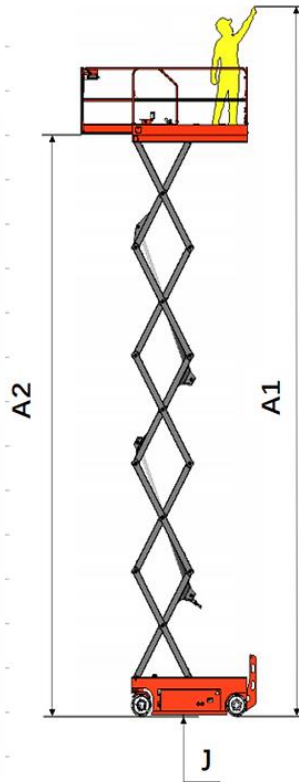

Model		ES40E
Load Capacity	(lb.)	500
Maximum Number of Workers (indoor/outdoor)		2/-
Lifting height Max.	(in)	157.5(13.1')
Length X Width	(in)	50.4 x 29.1
Platform Extension Size	(in)	23.6
Max Working Height	(in)	236.2(19.6')
Lowered height	(in)	76.8(6.4')
Guardrail height	(in)	43.31
Driving Speed (Lifted state/lowered state)	(km/h)	0-0.8/0-4
Rise/fall time	(S)	25/25
Battery	(V/Ah)	12x2V/100Ah
Charger	VAC	100-240
Service Weight	(lb.)	2050

EKKO ES60E Scissor Lift Aerial Platform

The EKKO ES60E Scissor Aerial Work Platform is a 506-lb capacity compact platform with four wheels and Curtis controller which allows you to make lifting, transporting loads, and moving products easily and safely. This product also complies with GB25849 and EN280 standards.

- Load Capacity 500 lb.
- Raised Height 19' (228")
- Lowered Height 86"
- Size: Length 65" x Width 30"
- Steel construction
- 3 Years Limited Warranty

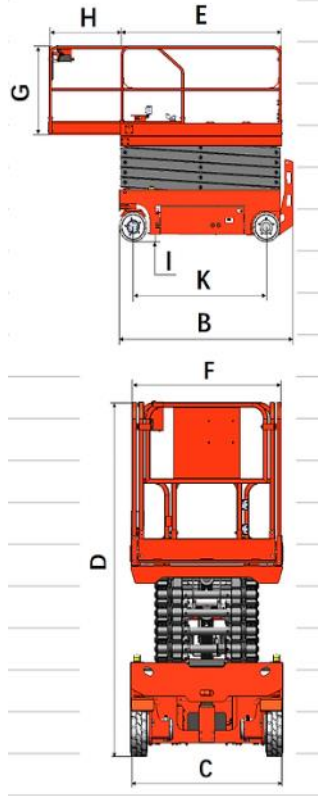
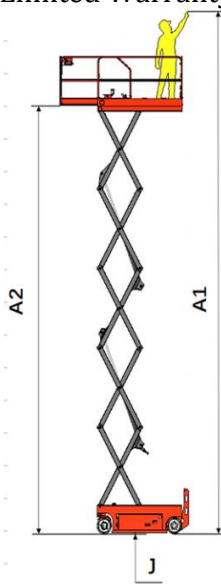

Model		ES60E
Load Capacity	(lb.)	500
Maximum Number of Workers (indoor/outdoor)		2/-
Lifting height Max.	(in)	228"(19')
Length X Width	(in)	72.44x29.92
Platform Extension Size	(in)	35.43
Max Working Height	(in)	307"(25.6')
Lowered height	(in)	86"(7.2')
Guardrail height	(in)	43.31
Driving Speed (Lifted state/lowered state)	(km/h)	0-0.8/0-4
Rise/fall time	(S)	18/28
Battery	(V/Ah)	6x4V/180Ah
Charger	VAC	100-240
Service Weight	(lb.)	3256

EKKO ES80E Scissor Lift Aerial Platform

The EKKO ES80E Scissor Aerial Work Platform is a 990-lb capacity compact platform with four wheels and Curtis controller which allows you to make lifting, transporting loads, and moving products easily and safely. This product also complies with GB25849 and EN280 standards.

- Load Capacity 990 lb.
- Raised Height 26.2' (315")
- Lowered Height 90.6"
- Size: Length 89" x Width 45"
- Steel construction
- 3 Years Limited Warranty

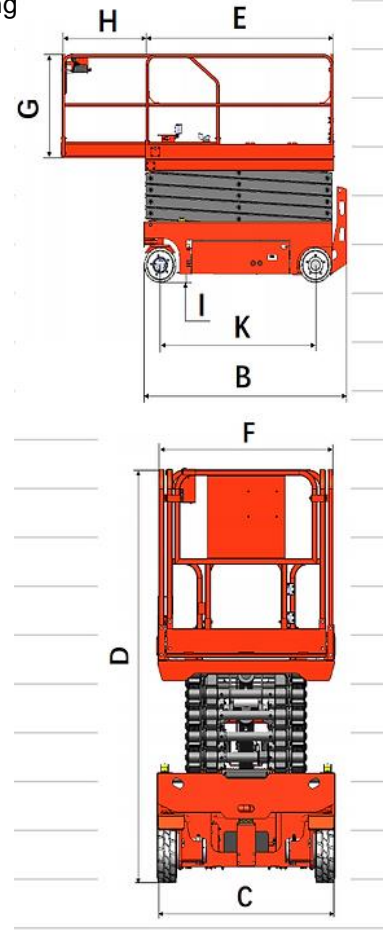
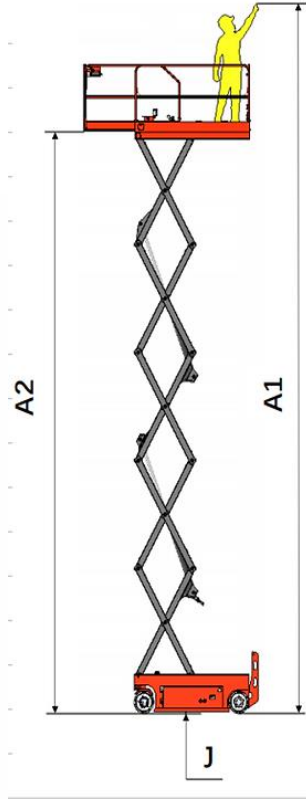

Model		ES80E
Load Capacity	(lb.)	990
Maximum Number of Workers (indoor/outdoor)		2/1
Lifting height Max.	(in)	315"(26.2')
Length/Width	(in)	94.5/45.27
Platform Extension Size	(in)	39.37
Max Working Height	(in)	394"(32.8')
Lowered height	(in)	90.6"(7.5')
Guardrail height	(in)	43.3
Driving Speed (Lifted state/lowered state)	(km/h)	0-0.8/0-3.2
Rise/fall time	(S)	32/35
Battery	(V/Ah)	6x4V/180Ah
Charger	VAC	100-240
Service Weight	(lb.)	5412

EKKO ES100E Scissor Lift Aerial Platform



The EKKO ES100E Scissor Aerial Work Platform is a 700-lb capacity compact platform with four wheels and Curtis controller which allows you to make lifting, transporting loads, and moving products easily and safely. This product also complies with GB25849 and EN280 standards.

- Load Capacity 700 lb.
- Raised Height 32.8' (394")
- Lowered Height 96.85"
- Size: Length 89" x Width 45"
- Steel construction
- 3 Years Limited Warranty

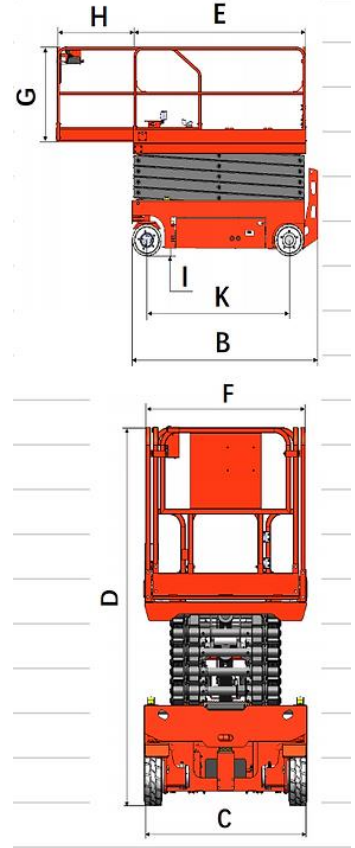
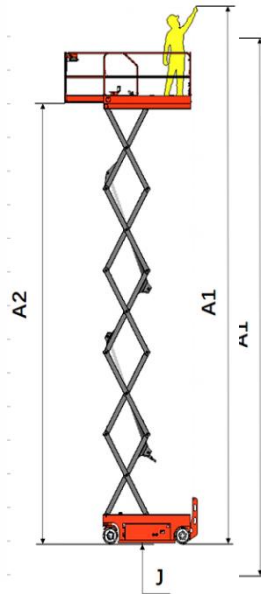

Model		ES100E
Load Capacity	(lb.)	700
Maximum Number of Workers (indoor/outdoor)		2/1
Lifting height Max.	(in)	394"(32.9')
Length/Width	(in)	94.5/45.27
Platform Extension Size	(in)	39.37
Max Working Height	(in)	472"(39.3')
Lowered height	(in)	96.85"(8')
Guardrail height	(in)	43.3
Driving Speed (Lifted state/lowered state)	(km/h)	0-0.8/0-3.2
Rise/fall time	(S)	52/48
Battery	(V/Ah)	6x4V/180Ah
Charger	VAC	100-240
Service Weight	(lb.)	6204

EKKO ES120E Scissor Lift Aerial Platform

The EKKO ES120E Scissor Aerial Work Platform is a 700-lb capacity compact platform with four wheels and Curtis controller which allows you to make lifting, transporting loads, and moving products easily and safely. This product also complies with GB25849 and EN280 standards.

- Load Capacity 700 lb.
- Raised Height 39' (468")
- Lowered Height 102.36"
- Size: Length 89" x Width 45"
- Steel construction
- 3 Years Limited Warranty

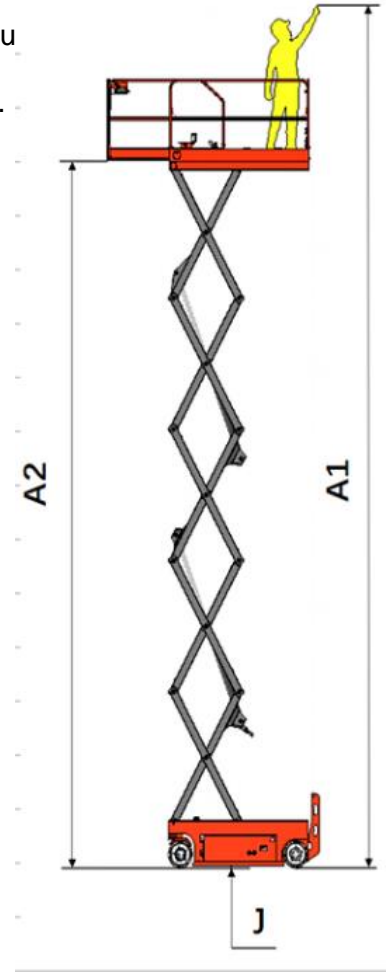
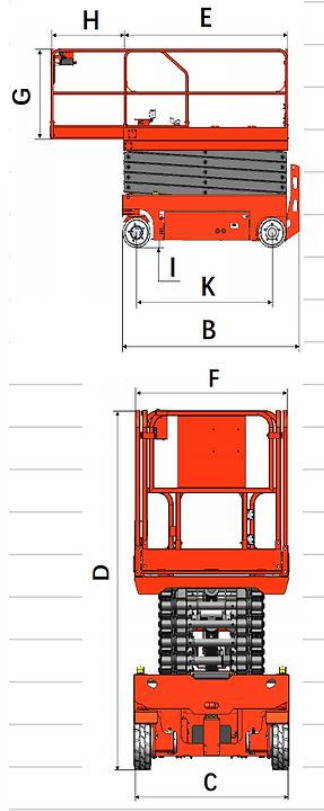

Model		ES120E
Load Capacity	(lb.)	700
Maximum Number of Workers (indoor/outdoor)		2/-
Lifting height Max.	(in)	468' (39')
Length/Width	(in)	94.5/45.27
Platform Extension Size	(in)	39.37
Max Working Height	(in)	547" (45.6')
Lowered height	(in)	102.36" (8.5')
Guardrail height	(in)	43.3
Driving Speed (Lifted state/lowered state)	(km/h)	0-0.8/0-3.2
Rise/fall time	(S)	52/52
Battery	(V/Ah)	6x4V/240Ah
Charger	VAC	100-240
Service Weight	(lb.)	6490

EKKO EG30 Tow Tractor

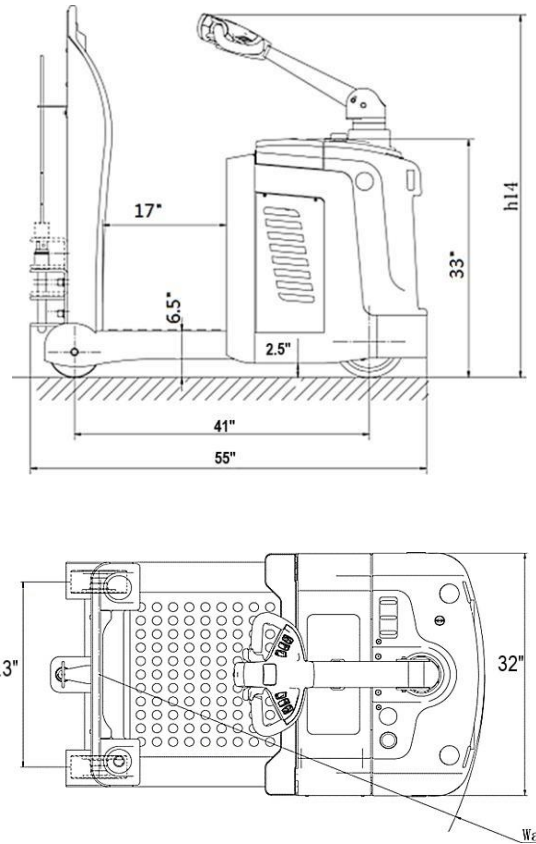

The EKKO EG30 Tow Tractor is designed for tugging and pulling applications made with quality materials, components and workmanship. Every product is robotically welded, powder coated and is reliable for loading and unloading trucks, loading docks, stock rooms, manufacturing floors and warehousing.

Made from high quality steel and components to withstand any terrain, usage, impact and directional changes for the use of any application with confidence and assurance.

- Tow Capacity 10,000 lb.
- Curtis Instrument Controller
- AC Drive 1.3
- Standing Drive
- Polyurethane Wheels
- EPS (Electronic Power Steering)
- Ergonomic Handle and Controls
- Steel Construction
- Robotic Welding
- 24V/210Ah
- 3 Year Limited Warranty

Model		EG30
Power unit		Electric
Operation		Standing
Tow Weight	(lb.)	10,000
Overall length	(in)	55
Overall width	(in)	32
Overall Height	(in)	53
Turning radius	(in)	49
Max gradient performance laden/unladen	(%)	3/15
AC Drive motor	(W)	1300W
Battery voltage/rated capacity	(V/Ah)	24V/210Ah
AC Drive Motor		AC Motor speed control
Noise level at operator seat	(dB(A))	68
Service weight (w/ battery)	(lb.)	1445

EKKO[®]

MATERIAL HANDLING EQUIPMENT



EKKO Material Handling Equipment Mfg. Inc.

1761 W. Holt Ave.

Pomona, CA. 91768

T: (877) 232-6517

O: (909) 222-6529

F: (909) 222-6861

info@ekkolifts.com

www.ekkolifts.com