

EKKO[®]

MATERIAL HANDLING EQUIPMENT

MOVING AHEAD

Lithium-ION PALLET JACKS EP15LI

- LITHIUM-ION
- 3300 lbs. Capacity
- Forks 27x48
- Compact & Economical
- Polyurethane Wheels
- Stability Casters
- Electromagnetic Braking
- 24V/35Ah
- Battery and Charger Included
- 3 Year Limited Warranty



EP15LI

Superior quality, maneuverable, compact, and durable for all your material handling applications. Ideal for small aisles and areas.

WEIGHT CAPACITY: 3300 lbs.

LIFT HEIGHT: 7.87"

FORK LENGTH: 27x48"

TURNING RADIUS: 58"

Li-ion BATTERY / On- Board CHARGER: 24V 35Ah,
24-volt Lithium-ion

SPEED TRAVEL: 4.5 mph empty ; 4.2 mph loaded

LIFTING SPEED: 1.1 ips empty; .8 ips loaded

LOWERING SPEED: 1.5 ips empty; 1.5 ips loaded

DRIVE WHEELS: 9.84" x 2.91" polyurethane

STABILITY CASTERS: 1.97" x 1.18" polyurethane

LOAD WHEELS: (2) 3.15" x 3.35" polyurethane

HYDRAULICS LIFTING MOTOR: 24V 800 Watt lifting motor with hardened chrome moly steel for durability.

DRIVE MOTOR: 24V 750 Watt drive motor for efficiency and high torque.

CONTROLLER: 24V provides performance through entire range of speed; Constant travel speed regardless of load; Battery discharge indicator combination gauge.

BRAKES: Electro-magnetic braking for secure stopping power; Electronic neutral braking for accurate control.

OPERATOR CONTROLS: Throttle, lifting, lowering, turtle mode and horn functions are located in the ergonomic handle; release lower handle; belly button reverse safety feature allows the unit to stop and reverse to avoid collision or injury.

CHASSIS AND MAST: Robotic Welding; Heavy duty steel for durability.



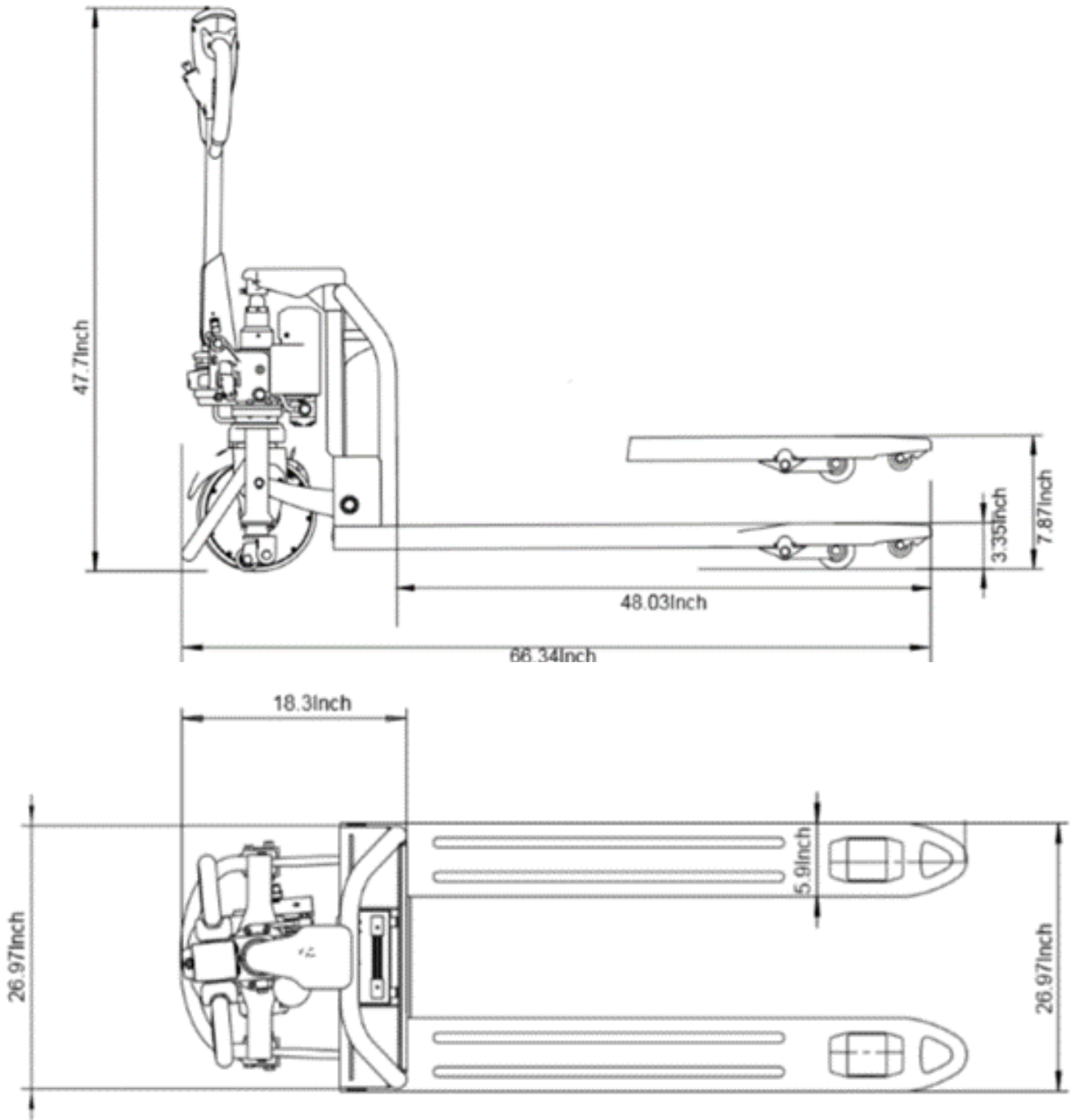

MODEL #	LOAD CAPACITY	FORKS	BATTERY	SERVICE WEIGHT
EP15LI	3300lbs	27x48	24V/35Ah	352lbs