

EP15SLP/EP18SLI

ELECTRIC PALLET TRUCK

INSTRUCTION MANUAL



WARNING!

You must read the instructions in this manual before using it.

Attention:

- Please check this document and the identification of the product type on the nameplate.
- Take care to keep it for future use.

EKKO[®]
MATERIAL HANDLING EQUIPMENT
MOVING AHEAD

Foreword

Before operating this truck, please read this manual carefully and fully understand the use of the truck. Improper operation may cause danger. This manual describes the use of different types of pallet trucks. When repairing the trucks, please ensure that they match your model.

Please keep it for future use. If this manual or warning/warning label is damaged or lost, please contact your local dealer to replace it.

This truck complies with EN 3691-1 (Industrial vehicles - Safety requirements and verification, Part 1), The standards of EN 12895 (Industrial vehicles - electromagnetic compatibility), EN 12053 (Safe industrial vehicles - test methods for the measurement of noise emissions), EN 1175 (Safety of industrial vehicles - electrical performance requirements) must ensure that the vehicle is used in accordance with the above purposes.

According to EN 12053, the noise level in the driver's ear is less than 70 dB(A).

Attention:

Hazardous waste that is harmful to the environment, such as waste batteries, waste oil and electronic products, if not properly disposed of, will have a negative impact on the ecological environment or human health.

Waste packaging should be classified into solid waste bins according to the material, and collected by the local special environmental protection bureau. In order to avoid pollution, it is forbidden to throw litter at random.

In order to avoid oil leakage when using the product, users should prepare some absorbable materials (waste wood chips or dry rags) to absorb the leaking oil in time. In order to avoid secondary pollution of the environment, used absorbable materials should be handed over to specialized departments in accordance with local authority regulations.

Our products continue to improve, because this manual is only for the operation/maintenance of the truck for the purpose, so this manual can not guarantee other special circumstances, please understand.



Note: In this manual, the symbols on the left indicate warnings and dangerous conditions that could result in death or serious injury if not followed.

Contents

- 1、 Proper use
- 2、 Vehicle technical parameters
- 3、 Accept training
- 4、 Self-protection
- 5、 Benefit
- 6、 Your walking pallet truck
- 7、 Pallet truck parts
- 8、 Instructions for use and operation
- 9、 Routine safety inspection
- 10、 Be a safe operator
- 11、 Battery maintenance
- 12、 Schematic diagram

1、 Proper use

This pallet truck is only allowed to be used in accordance with this instruction manual.

The truck described in this manual is a self-propelled pallet truck with the function of electrically operated height control. This truck is designed for lifting, lowering and transporting rack loads.

Improper use can result in personal injury or machine damage. The operator/operating company is required to ensure proper use and that the truck is only operated by trained and authorized personnel.

The truck must be used on a solid foundation, flat, intact plane and appropriate surface. The vehicle is designed for indoor use at room temperature from +5C to + 40C and for light load applications that do not require crossing permanent obstacles or potholes. Do not operate on slopes. When operating, the goods must be placed at the center of the load of the truck. Lifting or carrying of persons is strictly prohibited.

If used on lifting tail plates or loading platforms, ensure that these are used correctly according to the operating instructions.

The load rating is indicated on the load label and nameplate, and the operator must pay attention to these warning signs and safety instructions. Operating illumination must be at least 50 lux.

Changes
Any alteration that may affect the load rating, stability or safe operation of the vehicle shall be subject to the prior written approval of the vehicle's manufacturer of origin or its authorized manufacturer or its replacement. This includes the effects of changes such as increased braking, steering, visibility and movable accessories. When modifications or changes have been approved by the manufacturer or its replacement, load nameplates, labels, identification marks, operation and maintenance manuals will be changed accordingly.

Failure to follow these instructions to cause damage to the vehicle will result in loss of warranty.

2、 Vehicle technical parameters

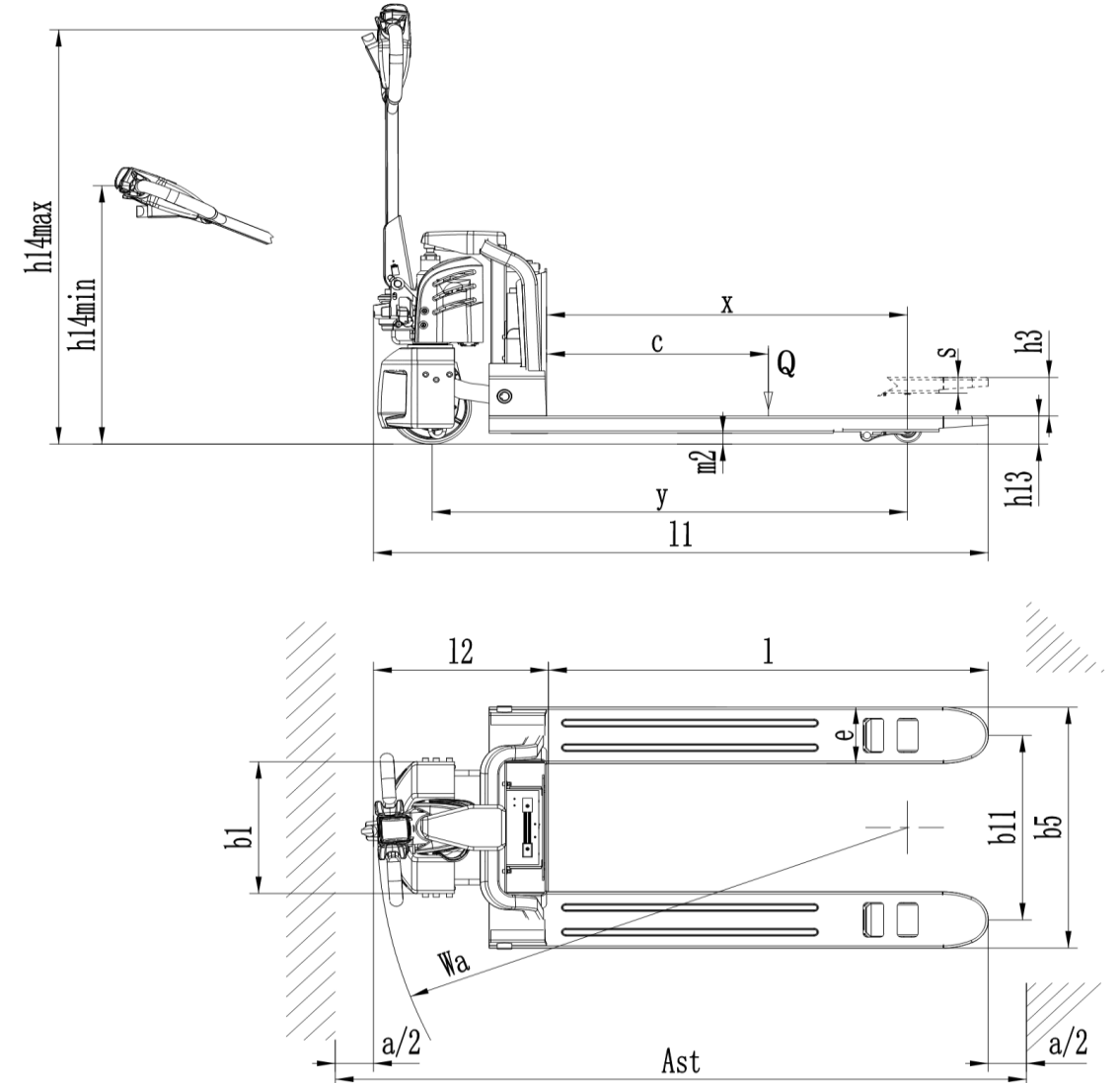

Distinguishing mark	1.2	Manufacturer's type designation		EP15SLI	EP18SLI
	1.3	Power(battery,diesel,petrol gas>manual)		Battery	
	1.4	Operation type		Pedestrian	
	1.5	Load capacity/Rated load	Q(lbs)	3,300	4,000
	1.6	load centre distance	C(in)	23.6	
	1.8	Load distance,centre of drive axie to fork	x(in)	37.2	
	1.9	Wheelbase	Y(in)	48.9	
Weight	2.1	Service weight	Lbs.	352.7	
	2.2	Axle loading,laden front/rear	Lbs.	\	
	2.3	Axle loading,unladen front/rear	Lbs.	\	
Tires,chassis	3.1	Tires		PU	
	3.2	Tire size,front	ΦxW (in)	Φ2.9x3.7	
	3.3	Tire size,rear	ΦxW (in)	Φ8.3x2.8	
	3.4	Additional wheels(dimensions)	ΦxW (in)	\	
	3.5	Wheels,number front/rear(x=driven wheels)		1x/2	
	3.6	Track,front	b10(in)	\	
	3.7	Track,rear	b11(in)	20.7	
Dimensions	4.4	Lift height	h3(in)	4.3	
	4.9	Height of tiller in drive position min/max	h14(in)	23.6/48.0	
	4.15	Height,lowered	h13(in)	3.1	
	4.19	Overall length	l1(in)	63.3	
	4.20	Length to face of forks	l2(in)	18	
	4.21	Overall width	b1(in)	14.8	
	4.22	Fork dimensions	s/e/l(in)	2.0/6.3/45.3	
	4.25	Distance between fork-arms	b5(in)	27	
	4.32	Ground clearance,centre of wheelbase	m2(in)	1.2	
	4.33	Aisle width for pallets 1000X1200 crossways	Ast(in)	86.2	
	4.34	Aisle width for pallets 800X1200 lengthways	Ast(in)	81.1	
4.35	Turning radius	Wa(in)	54.6		
Performance	5.1	Travel speed,laden/unladen	Mph	2.6/2.8	
	5.2	Lift speed,laden/unladen	in/s	0.9/0.7	
	5.3	Lowering speed,laden/unladen	in/s	1.0/1.2	
	5.8	Gradeability, laden/unladen	%	6/10	
	5.10	Service brake		Electromagnetic	
Motors	6.1	Drive motor rating S2 60min	Hp	1.0	
	6.2	Lift motor rating at S3 10%	hp	0.7	
	6.3	Battery, acc to DIN 43531/35/36 A,B,C, no		\	
	6.6	Energy consumption acc. to VDI cycle	KWh/h	\	
Additional data	8.1	Type of drive control		DC speed contro	
	8.4	Sound levei at driver's ear acc. to EN 12053	dB(A)	69	

3、Accept training

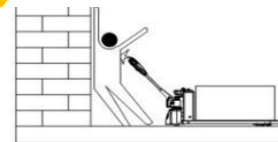
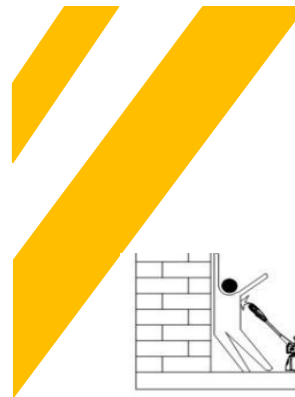

Do not operate a vehicle in your workplace without training and certification. It may affect your own safety if you have not get adequate training in truck operation!

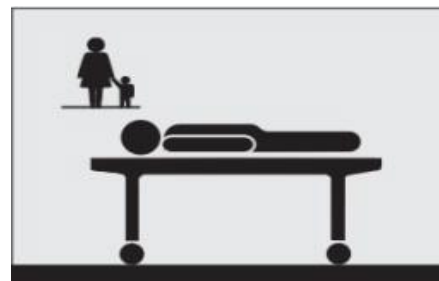

Regulations state that you must be trained and certified to operate the vehicle. If the vehicle is not used correctly, it will cause the safety of their own lives and the lives of others. Read and follow all warnings and instructions in the onboard operating manual. A fall from a loading platform or dock board can result in serious injury or death. To ensure your safety. Check the vehicle before starting work to make sure it is in good working order.



The law states that only properly trained operators can operate the vehicle, and your employer must train you and certify that you are qualified to operate the vehicle.

4、 Self-protection



Know the danger

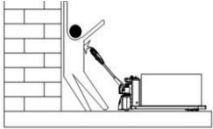

Observed moving region

Always be alert to the surrounding area and pay attention to where you are driving. Be careful not to be knocked against (e.g. a wall or post).

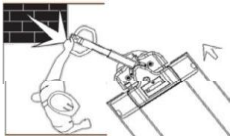

Drive with care

Watch your hands and feet to avoid crushing or breaking them. Drive sideways to avoid hitting your legs or feet and crushing your feet.



When starting the truck, hold the handle firmly with both hands. Change direction carefully and keep your feet away from the truck. Maintain control of the truck and drive at a safe speed. Drive carefully on smooth or uneven roads and do not crush foreign objects on the ground.

Avoid falling

Falling is a very serious accident, you can be crushed or even die. The best way to prevent injury is to always know where you are and follow safe operating rules. Be very careful when working around docks, loading platforms and trailers. Stay away from the edge of piers and ramps. Make sure the loading and unloading platforms are secure.

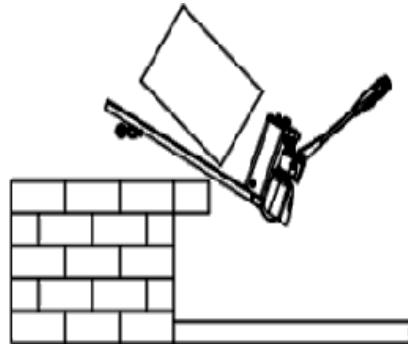

Safe use of trucks

Keep hands and feet away from all moving parts, such as forks or wheels. Do not ride or allow others to ride, and sit or stand in dangerous places. Before you leave the truck, place the fork on the floor and turn off the truck key to ensure that the loading and unloading platforms are secure.



5、 Benefit

What can benefit you?

The more you know about your truck and how to use it, the better and safer operator you will be. Here are some guidelines for using this manual.

• Fast positioning

In addition to the "Content" page, you can also use the page title to find topics. Some pages also have a picture of a truck in the corner, showing the features or functions covered on that page.

• Operation method

On many pages, you'll find pictures and text to help you understand how to use trucks safely and efficiently.

• Understand the hazard

Notice and read these special blocks. You will find information about possible security hazards and how to avoid them.

6、 Your walking pallet truck

Manufacture to standard

This truck is designed and manufactured according to current industry and government standards and guidelines. Suitable for moving goods in short distances and tight Spaces

Powerful, easy to hold 2 cars
Distinctive turn
A different braking system

When operating the truck for the first time, use both hands to operate the control handles. If you change direction, watch your feet.

When driving, stay on the side of the truck, slightly ahead of the drive. Use the hand closest to the truck to operate the control handle. Watch your feet. Stay away from the road path of trucks.

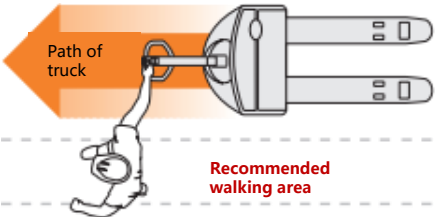
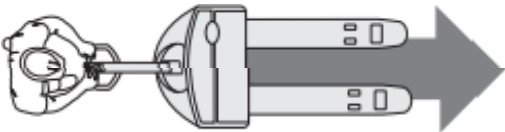
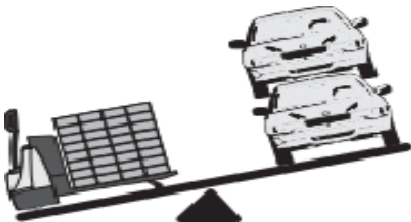
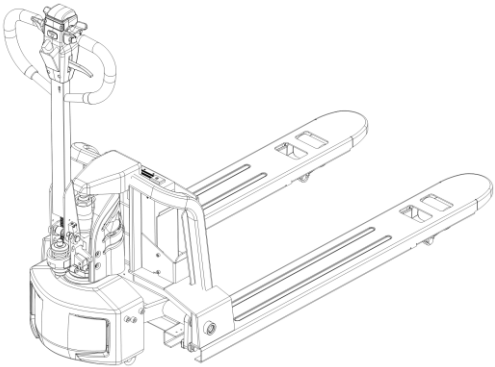

7、 Pallet truck parts

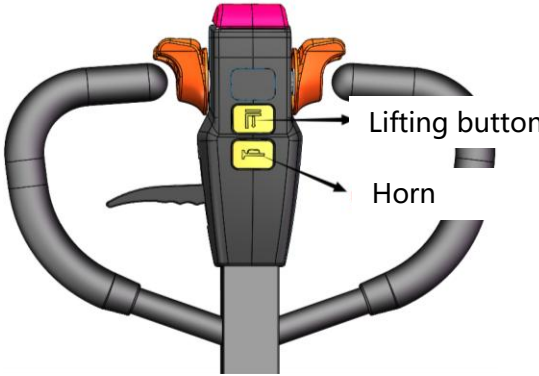
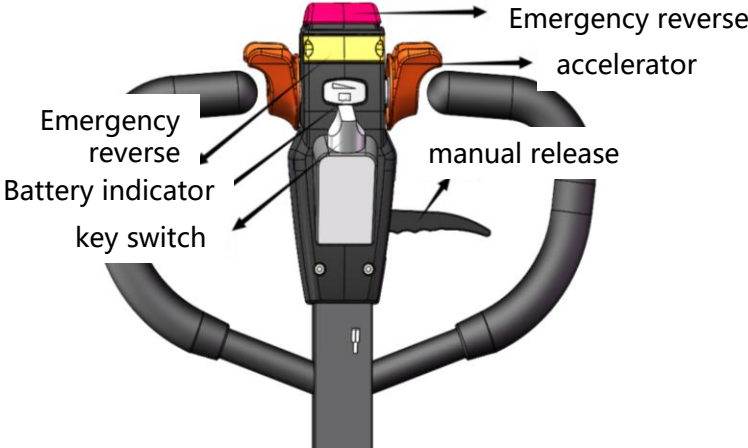

8. Instructions for use and operation

A. Magnetic movable key

Open the truck by inserting the magnetic key into the hole. After inserting the magnetic key, the panel LED lights up (as shown in Figure 1). Turn off the truck by removing the magnetic key. Always turn off the key when leaving the truck.

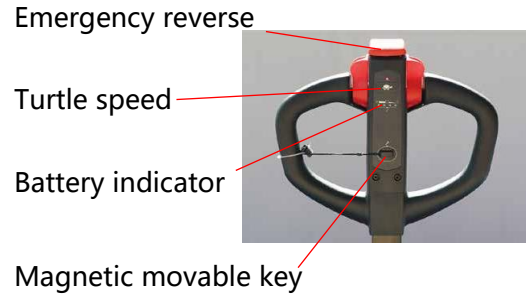

B. Emergency reverse

If you touch the reverse switch while the truck is moving in the direction of the person, the truck will move in the direction of the front fork (as shown in Figure 1). An emergency reverse cannot prevent all injuries.

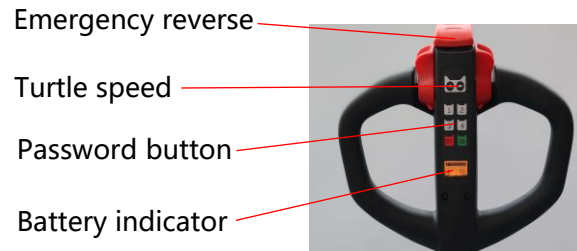

C. Turtle speed

Press the turtle switch on the control handle and turn the forward/backward rocker arm. (As shown in Figure 1)

D. Battery indicator

Show the remaining power (as shown in Figure 1)

E. Power off

Press the red scram switch to disconnect the battery and cut off all power (as shown in Figure 2). Whenever the truck does not work properly, disconnect the battery. The key switch won't cut off all power to the truck. If the truck is not working properly, do not use it and report the problem to your supervisor.

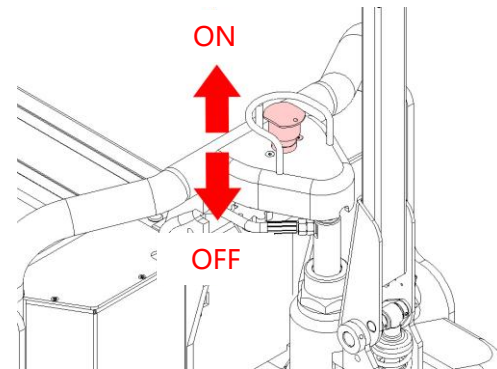

Figure 2

F. Braking

When the handle of the vehicle is in use, the handle can be used normally in the section B through the micro switch. In order to ensure the safety of users, the handle cannot be used normally in the section A and C. (as shown in Figure 3)

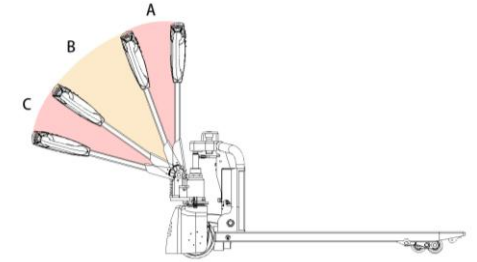

Figure 3

G. Brake control

If you must move the truck in a narrow area, place the handle in the brake area and press the turtle speed switch (as shown in Figure 4). When the indicator light is red, turn the forward/backward button to the slow driving position.

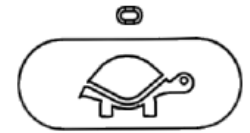

Figure 4



Know the danger



Make sure your brakes work test the brakes on the truck at the beginning of each trip.



H. Lifting or lowering

Push the lifting button (as shown in Figure 5) until the front fork reaches the desired height and then release the button.

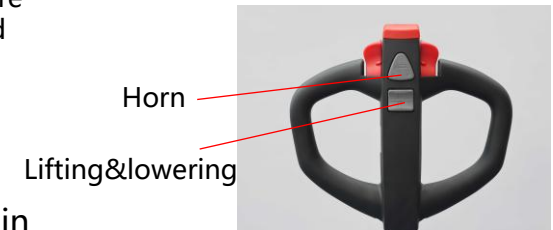

Figure 5

I. Horn

For warning reminders (as shown in Figure 5)

J. Turning

You can control the steering by moving the control handle from side to side. For example, this diagram shows the direction the truck can turn when the control handle is moved to the approximate position shown (as shown in Figure 6).

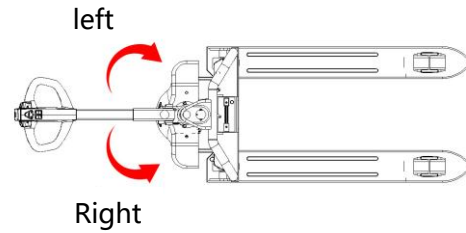

Figure 6



Know the danger

a. Drive steering

Turn carefully when driving the truck. The power plant will swing in the opposite direction. Make sure you have space and be aware of people in the area. (as shown in Figure 7)

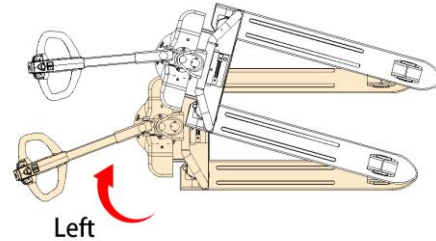

Figure 7

b. Slippery ground, slow driving

Powder or liquid spills can lead to slippery floors. Slow down or you may lose control of steering and braking. Be careful and allow longer parking distances. Do not run over objects on the floor (as shown in Figure 8)



Figure 8

K. Driving

Push the forward/backward button in the direction you want to travel. The further the button moves from the neutral position, the faster the truck moves. (as shown in Figure 9)

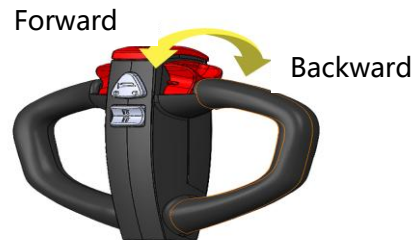

Figure 9

9. Routine safety inspection

**Check your truck before you start work
You must ensure that your truck is safe to use**

1. Walk around your truck and check it out.

Make sure the battery is charged Do not use a flame to check the battery. Make sure battery cables and connectors are not damaged or corroded. View all wheel conditions. Clean the control handle. Make sure the two front forks are straight and not cracked or badly worn. If your truck has this option, make sure the load backrest is in place and secured. Make sure there are no signs of hydraulic leaks under the truck. Test horn. Make sure all controls run smoothly.

2. Test your truck in an uncrowded area.

Test hydraulic function. Check the steering. Operate the forklift slowly in both directions. Operate at full speed forward and backward. Check forward and backward braking distances. Load size and floor conditions affect these distances.

Know the distance needed to stop before you start working. If the braking distance is too long to stop safely, do not use the truck. If anything doesn't look, work, or feel right, don't use the truck. Report problems to your supervisor.

10、 Be a safe operator

- **Make sure you are ready**

Do not use this truck unless you have been carefully selected and certified.
Make sure you understand how truck work and the dangers that come with them. If you have any doubts, do not use the truck.
Understand truck loads.
Some truck are not allowed in areas where there is a fire hazard. Make sure your truck is the right fire safety type and suitable for the job.
Make sure your hands and shoes are clean and dry, and your clothes are fit for work.

- **Make sure your truck is ready**

Check your truck before use. If it doesn't work properly, or if something is broken, Report problems to supervisor. Don't use trucks.
In an open area, test the brake. Drive at a slow speed first, then check at a faster speed. Know how long it will take to stop before you start working.
For wet or slippery floors, slow down, don't crush things, and pay attention to rough surfaces.
Make sure you have room to turn and watch the swing of the truck.
Slow down when turning
Avoid sudden movements and operate the truck at a suitable, even speed.
If you must use a truck in an area where there is a risk of falling objects, be very careful.

- **Pay attention to others**

Drive slowly or stop to let pedestrians go first. When you come to the intersection, please use the horn.
Be careful not to hit anyone.
No one is allowed to ride on the truck.
Other people should stay away from the vehicle while it is working.
No one is allowed to use a vehicle without training and certification.



- **Be careful when driving on ramps**

Stay out of the path of the truck
Regardless of whether there is a load, it should be driven with the fork pointing downhill.
If the load requires the use of a special fork, be more careful. Side operation truck.
Slow down and do not turn on ramps or slopes.

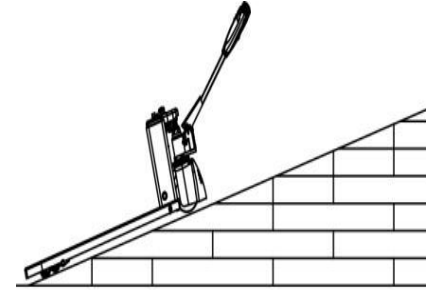

- **Avoid falling**

Stay away from the edge of piers and ramps.
Check whether the loading platform and dock plate are secure. Make sure the trailer wheels are secured to the dock.
Check the load to make sure your truck load is not overloaded.
Make sure the goods you move are stable and centered.
Extra long, tall, and wide goods should be more careful, as they may not be stable.
Do not force the truck onto the elevator unless authorized.
Check load or load limits to make sure no one is present.

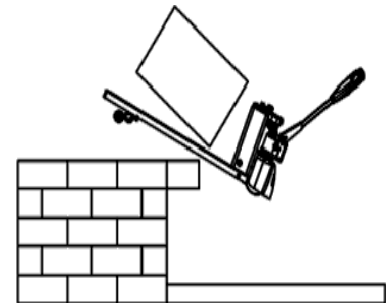

11、 Battery maintenance

Battery

The truck is equipped with industrial lithium-ion batteries, which need to be checked daily.

Recharger

To use a separate external charger, follow the instructions on the charger provided. Turn off the truck. Disconnect the battery connector. Connect the charger plug to the battery connector. Plug the other end of the power cable into an AC power outlet. Check the charging indicator on the charger.

Battery indicator

Green and yellow lights show how much battery power is left, and a blinking red will warn you that your battery is low. Two flashing red lights indicate that you must replace the battery or charge it.



Know the danger

Understand the precautions for dangerous charging

Unless you are trained and authorized to do so, do not attempt to install, remove, or service a truck battery. Charge the battery in the area designated for that purpose. Make sure the truck key switch is off and all controls are in the off or neutral position. For built-in charging, make sure the AC outlet has the same voltage as the battery charger. For external chargers, make sure the charger has the same voltage and amperage as the battery. Read the battery charger instructions. Before connecting the battery to the charger, make sure the charger is turned off, otherwise a spark may occur, which can cause the battery to explode

12、 Schematic diagram

Hydraulic schematic diagram

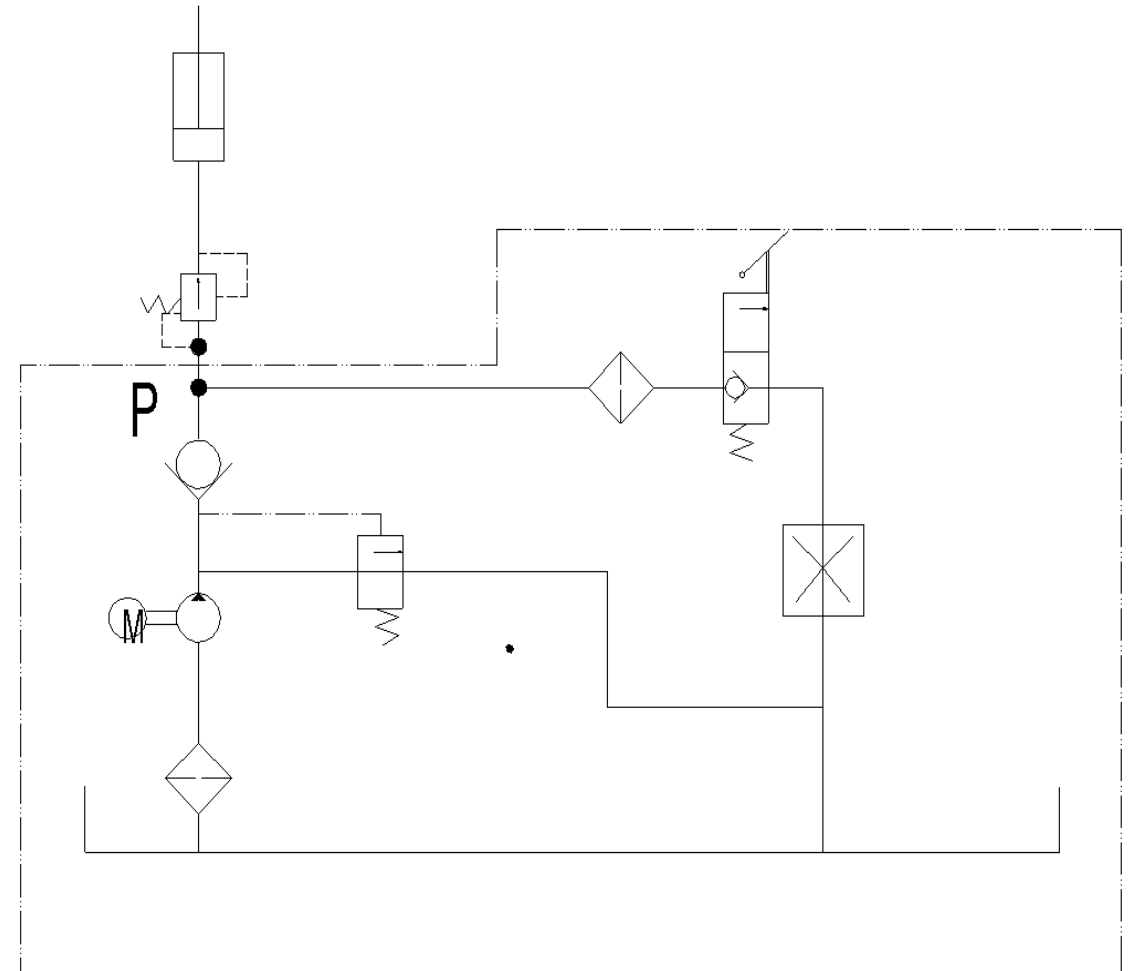

Electrical schematic diagram

