

The Specification

EB20E Serial Full Powered Walkie Stacker

Note: Before using must read this manual and the various warning label!

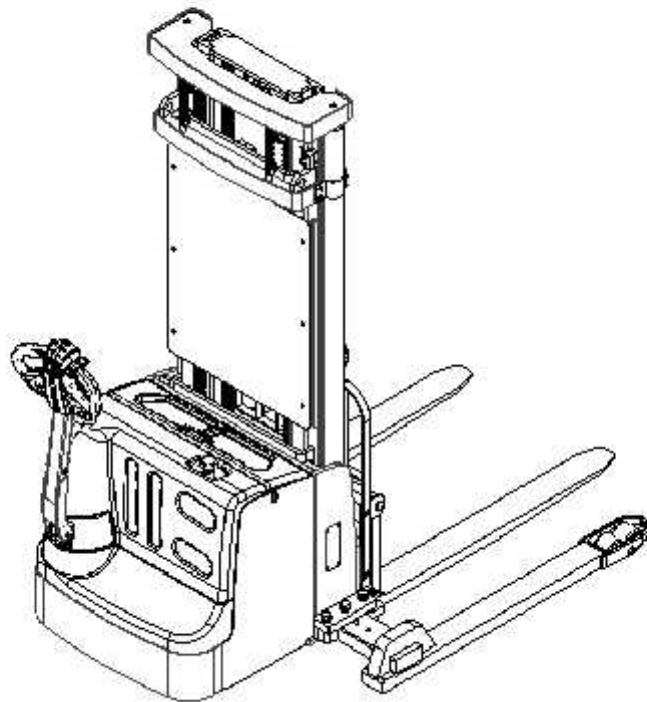

Contents

| | |
|--|-----------|
| 1.The General Introduction | 2 |
| 2.Proper usage | 2 |
| Modification | 3 |
| 3.Introduction of the product | 3 |
| 3.1 Model Overview | 4 |
| 3.2 Model..... | 4 |
| 4.Operating principle..... | 5 |
| Operating mechanism diagram: | 6 |
| 5.Operating principle..... | 6 |
| 5.1 Running system | 7 |
| 5.2 Steering system | 7 |
| 5.3 Braking system | 7 |
| 5.4 Operating System..... | 8 |
| 5.5 Electric System | 8 |
| 5.6 Hydraulic principle | 9 |
| 6.Electrical schematic diagram | 9 |
| 7.Hydraulic Principle Diagram..... | 10 |
| 8.Operating instruction..... | 11 |
| 8.1 Start, run and parking:..... | 11 |
| 8.2 The usage of emergency safety switch | 12 |
| 8.3 The usage of horn button..... | 12 |
| 8.4 Battery capacity indicator | 12 |
| 8.5 Handling stacking operation | 12 |
| 9.Maintenance | 13 |
| 9.1 Safety procedures for repair and maintenance | 13 |
| 9.2 Daily Maintenance..... | 14 |
| 9.3 Professional Maintenance Manual | 14 |
| 9.4 Maintenance, Recharging and Replacement of the accumulator | 16 |
| 10.Safety Precautions | 19 |
| 10.1 general rules | 19 |
| 10.2 Transportation and storage | 19 |
| 10.3 Check before Using..... | 20 |
| 10.4 Safe Operation..... | 20 |
| 11.Repair Manual..... | 22 |
| 11.1 Malfunction analysis | 22 |
| 11.2 preparation work before repair | 22 |
| 11.3 check the oil content of hydraulic oil | 23 |
| 11.4 preparation work before use after maintenance..... | 23 |

1.The General Introduction

EB20E ,this stacker is equipped with a wide view lifting system, a new dc controller and other advanced structures, and a high quality motor, traction battery and a high-power pump station motor. It has the characteristics of superior performance, convenient operation, wide vision, flexible steering, reliable braking, good power performance, less noise, no pollution, good appearance and so on.

This stacker is suitable for working on the smooth ground in warehouse ,if not, please don't use it.

The service environment:

- a. temperature: $-10^{\circ}\text{C} \sim +40^{\circ}\text{C}$;
- b. the gradient less than 3%;
- c. when environment temperature at $+40^{\circ}\text{C}$,the relative humidity should be less than 50%, At low temperature , higher humidity is allowed;
- d. ground need hard and flat;
- e. It is forbidden to use this car in corrosive environment such as flammable and explosive or acid base.

2.Proper usage

Please using the electric stacker accord to this specification.

This is a walkie type electric pallet truck with autonomous control, lifting and lowering is controlled by the handle button. Improper use can cause personal injury or machine damage. Operators or operating companies need to ensure proper using,

The Truck needs to be used on a firm, flat, intact surface and suitable surface ,The truck is designed for indoor use at room temperature from -10°C to +40°C

Use under light load without using permanent barriers or pits, It is forbidden to operate on the slopes.

Lifting or Carrying people is strictly prohibited ,If carried goods .The goods must fall on the lifting point 。

It is prohibited to use this truck on lifting or loading ramps 。

The rated capacity is marked on the capacity label or nameplate. And the operator must pay attention to the warning signs and safety instructions

Operating lighting must be at least 50LUX.

Modification

Any modification that may affect the truck rated capacity, stability, or safety operations must be approved in advance by the Truck's original manufacturer or Its authorized Manufacturer or its successor. This includes the effects of changes such as Braking, steering, Visibility, and the addition of removable accessories.

After the manufacturer or its successor approves the modification or change, The capacity name plate, Label, identification marks, operation and maintenance manual must be changed accordingly

3.Introduction of the product

3.1 Model Overview

This specification is for EB20E series 4400LBS tramp type full powered walkie stacker (follow as stacker) 。

3.2 Model

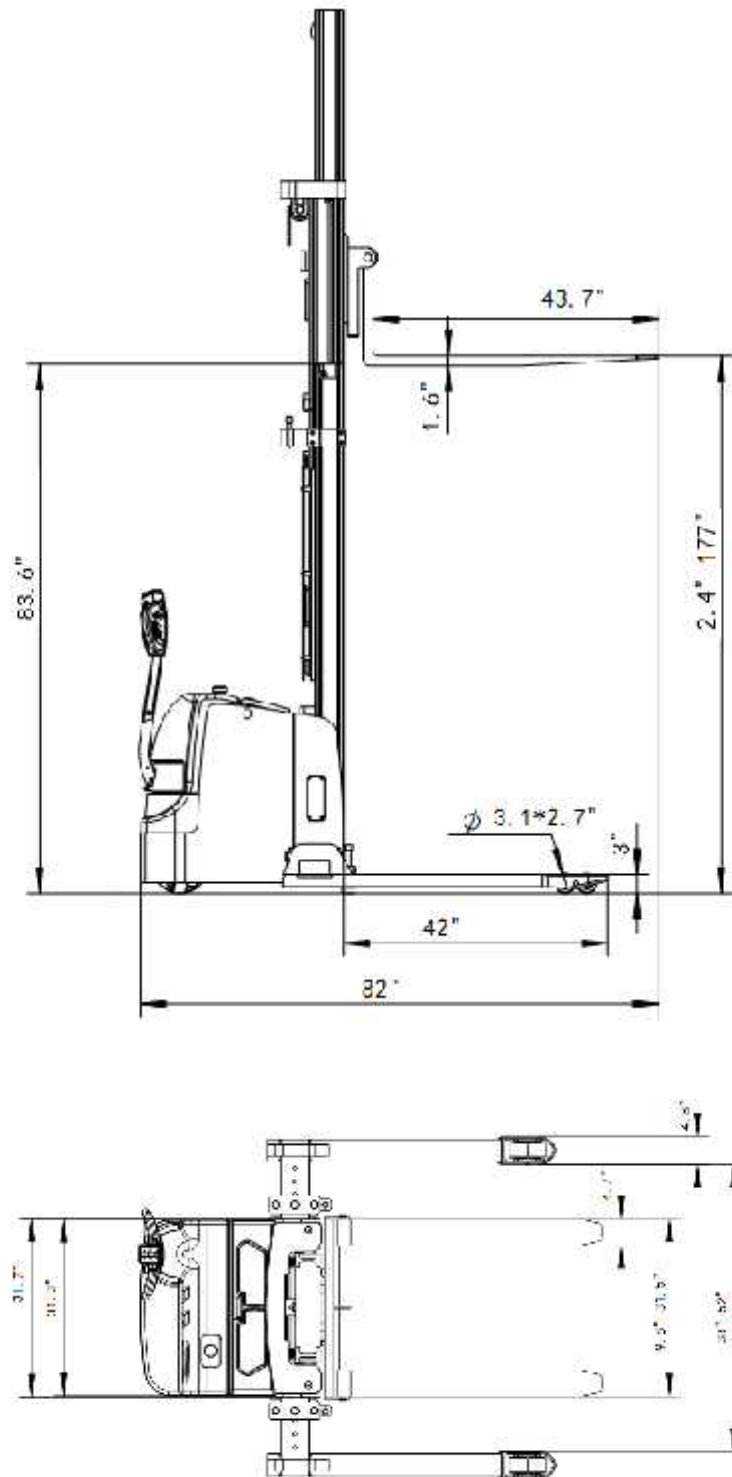

| | | |
|-------------------------|------|------|
| Mode | | |
| Load Capacity | (lb) | 4400 |
| The max. Lifting height | (in) | 177 |
| Load center distance | (in) | 24 |

| | | |
|----------------------|------|---|
| Fork length | (in) | 45.3 |
| Single fork width | (in) | 4.7 |
| Overall fork height | (in) | 9.8-31.5 |
| Lowered fork height | (in) | 3 |
| Fixed leg length | (in) | 42 |
| Adjustable legs | (in) | 45.5-59.1 |
| Turning radius | (in) | 60 |
| Overall length | (in) | 82 |
| Max overall width | (in) | 61 |
| Extended mast height | (in) | 198 |
| Lowered mast height | (in) | 83.6 |
| Battery voltage | V/ah | 24/210 |
| The charger | V/A | 24/30 |
| Lifting motor | V/Km | 3kw.Lift speed, laden/unladen:92/136mm/s; Lowering speed, laden/unladen:112/98mm/s |
| Driving motor | | 1.5kw. Driving speed: laden/unladen:4.0/4.2km/h |
| Service weight | (in) | 3014 |

4.Operating principle

With battery as power producer and controlled by electrical and hydraulic, trucks can do some actions like walking, turning, pallet fork lift, etc.

Operating mechanism diagram:

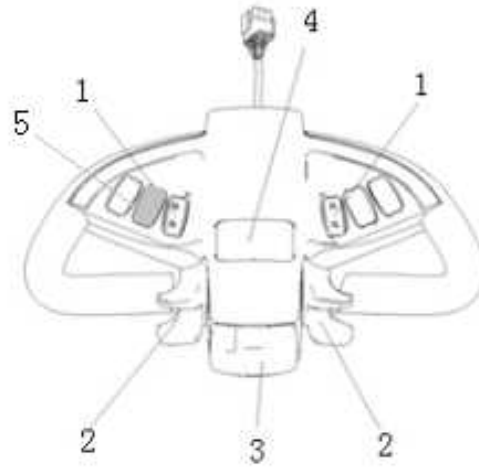

1.Switch for lifting and lowering

2. Switch for driving

3.Belly switch

4.Horn

5.Coulombmeter

5.Operating principle

5.1 Running system

The truck is powered by a battery, which is realized by controlling the AC motor on the drive wheel. The speed of walking is realized by frequency conversion control motor speed, which is controlled by the accelerator.

Gear box in the factory has been posited with enough gear lubricating oil. And please change the gear lubricating oil every 1000 hours under normal circumstances.

If you hear abnormal sound from gear box when using, please stop and check immediately. If there are bearing failure or some problems in gear, please replace and repair them.

5.2 Steering system

The operating handle drives the rotation direction sensor which can send out the turn signals that makes the truck turn around.

5.3 Braking system

Braking performance depends on road conditions and vehicle load conditions。

5.3.1 The brake function can be activated by the following way:

A: Move the Fahrschalter (2) to position '0', The vehicle brake until it stops.

B: Move the travel switch directly to the opposite direction, vehicle regenerative braking until it began in the opposite direction.

C: Vehicle braking, if the handle is moved up and down to the braking area ("B"). If the release handle, the handle automatically moves to the braking area ("B") vehicle brake until it stops.

D: Belly switch (3) Can prevent the operator will be squeezed, if the button to activate, behind the vehicle to slow down or start to ('Bw') driven a short distance, then stop. If the handle is in operation area and vehicles is not driving, please consider this button to throw this situation.

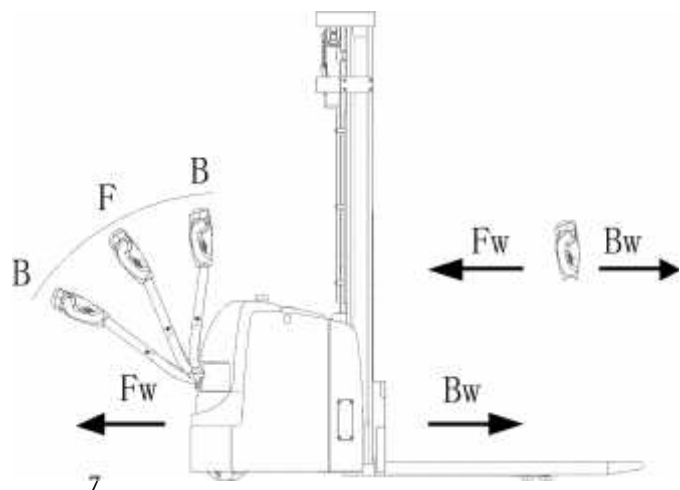

5.3.2 Brake operating principle

As shown in the following figure, the brake consists of magnetic yoke assembly 6, excitation coil 7, spring 2, brake disc 5, armature 1, gear sleeve 4, installation screw 3, etc. The brake is mounted on the end cover of the motor and the mounting screw is adjusted to the specified air gap value. The gear sleeve is fixed on the shaft, its outer tooth and the inner tooth of the brake disc cooperate, when the torque is transferred, the brake disc can move axially on the gear sleeve.

When the actuator coil 7 is energized, the coil produces a magnetic field that causes armature 1 to draw toward the magnet yoke assembly 6 and armature 1 to detach (release) from the brake disc 5. At this time motor drive shaft with brake disc 5 start and operate normally. When coil 7 is cut off, the magnetic flux disappears, armature 1 is released, and spring 2 presses armature 1, and compresses the friction plate on the brake disc, generating friction force to achieve the purpose of braking.

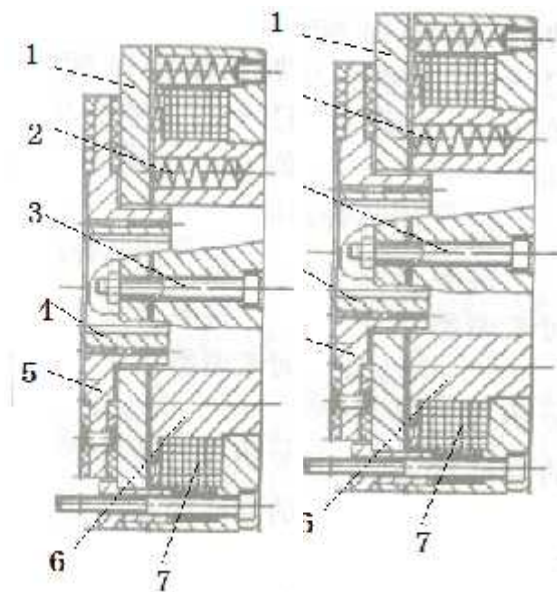

5.4 Operating System

The main working part of truck is fork, which are used to carry the pallet or cargo for transport and short distance transportation. The expansion of the cylinder is realized by the control of the operating handle, and the pressure oil is provided by the pumping station.

5.5 Electric System

The electrical system includes walking and operation control. The truck use AC electric control assembly. The meter has a battery indicator. When the battery power is too low, the electric meter will cut off the starting control line of the oil pump motor. The moving truck can only walk without lifting the fork, and the prompt should be charged immediately. The motor of oil pump is the dc motor for 5 minutes, so the pump motor is not suitable for

long running. That is, the lifting movement should have time interval, cannot continuously carry on, otherwise would make the motor heating, even burn.

Special note: when the truck is used for a long time, the starter of the oil pump motor may fail, and it can't be broken after being sucked or closed. The latter is not throw control handle, the oil pump motor is kept in the rotation, should immediately stop at this moment, to cut off the power supply (unplug battery plug-in), make the oil pump motor stop running, and promptly replace the starter.

5.6 Hydraulic principle

The oil pump motor drives the gear pump to provide hydraulic power, lifting oil cylinder is responsible of fork's lifting and lowering, The control of the lift oil road is controlled by the buttons on the operating handle, The lifting action is controlled by a single action oil circuit on the valve block. This model of the hydraulic system pressure can only be adjusted on the valve block, has been debugging good, before they go out after they leave the our company after-sales personnel or professional maintenance personnel are strictly forbidden to adjust themselves, so as to avoid safety accident.

6.Electrical schematic diagram

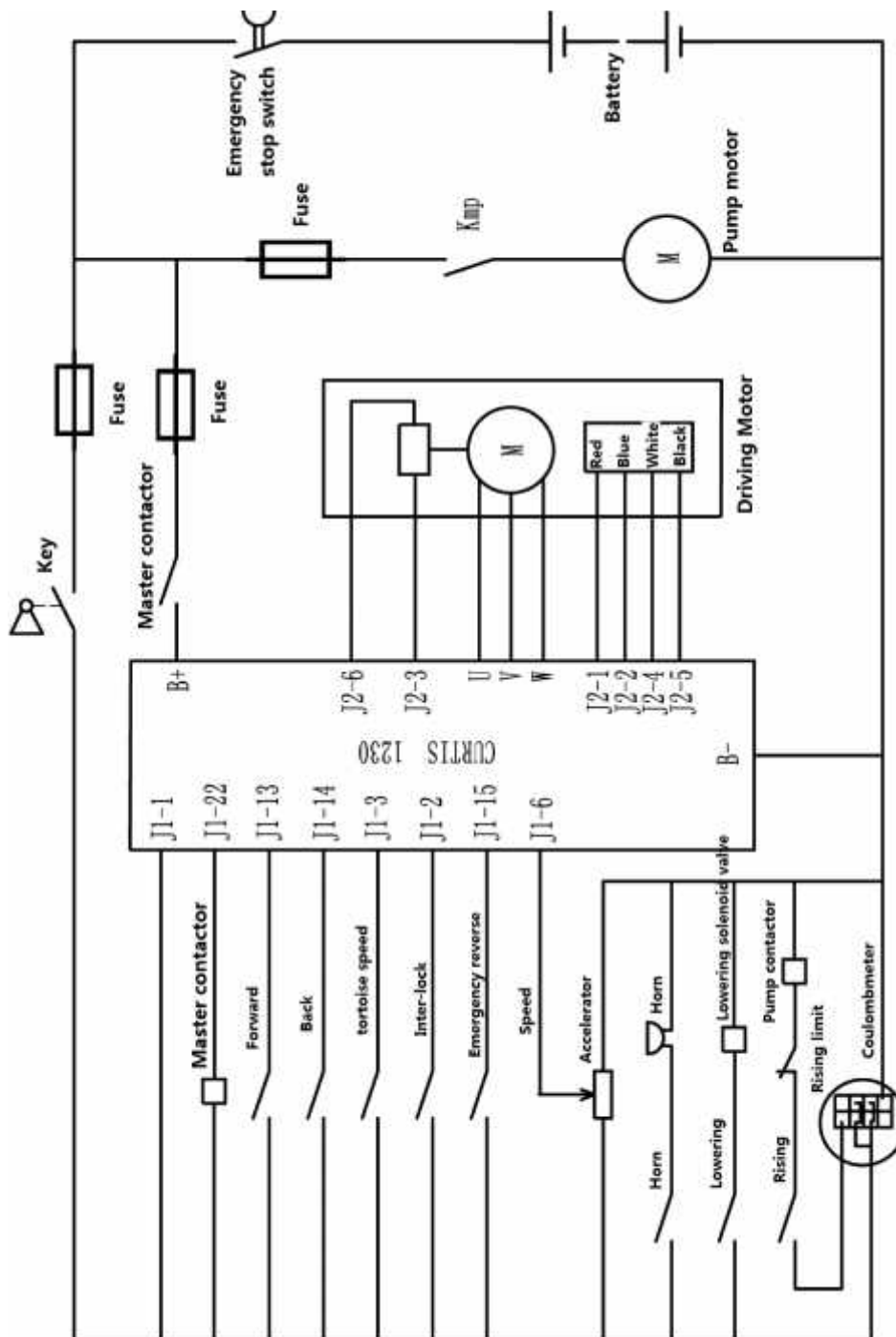

7. Hydraulic Principle Diagram

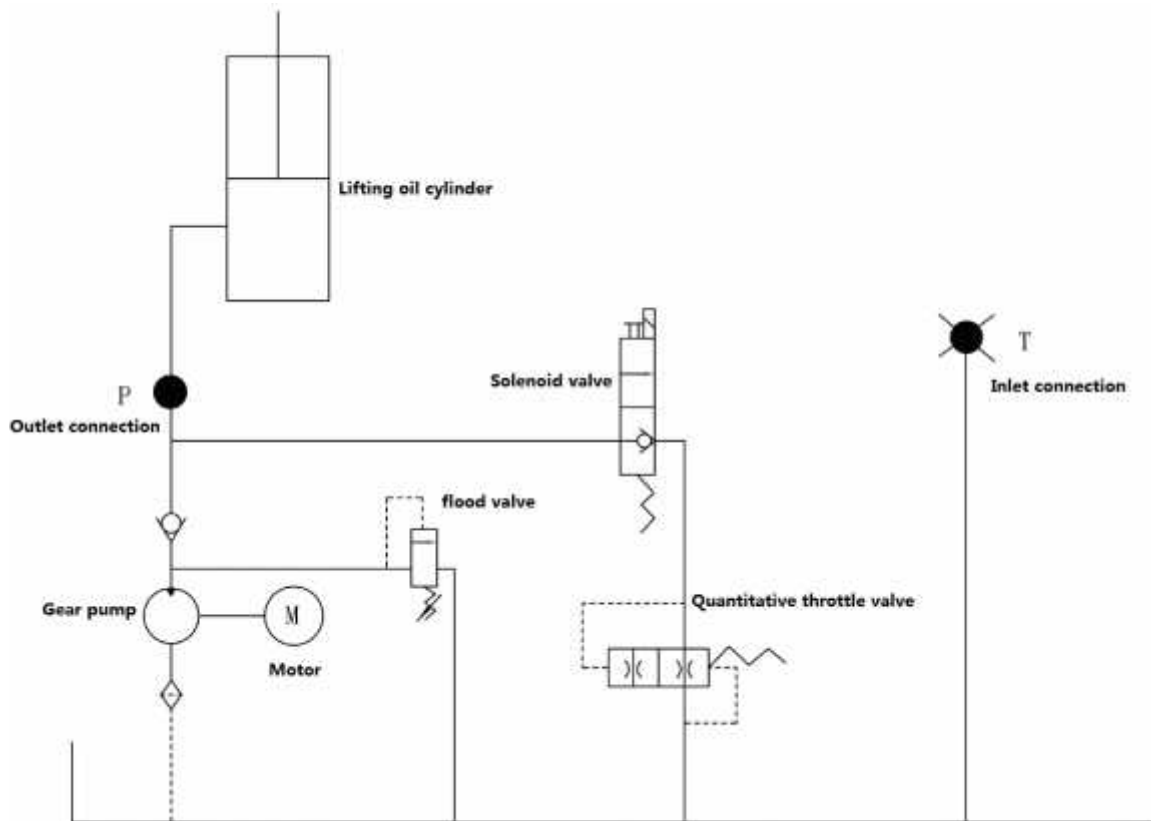

8.operating instruction

Before operation, please be familiar with the function of each switch/button on the instrument panel.

8.1 Start, run and parking:

- 1).Insert the key into the key switch, turn to the right, pull the emergency power safety switch up, open the control circuit.
- 2).Forks rise above ground about 10 cm

3).Turn on the travel switch slowly, till the requested speed

4).Any fault of the truck happening during operation, need to cut off the power immediately, and press the red emergency power switch down.

5).Avoid to take a sudden turn during driving the truck.

6).Using stacker full load climbing a slope, need to know the condition of the slope, and press the travel switch as much as possible to get a maximum grade ability.

7).When stop driving ,put the fork in the bottom, press the emergency switch down, and pull out the key.

8.2 The usage of emergency safety switch

Press the emergency safety switch down, then the truck's power off. Method to open it: pull the red button up.

Emergency safety switch is made of plastic, too much pressure may damage it.

8.3 The usage of horn button.

Press the horn button in the center of handle to notify people around.

8.4 Battery capacity indicator

The stacker battery capacity indicator has electricity capacity display function.

8.5 Handling stacking operation

1). How to transport the goods pile on weight

Will forklift drive to the front of the items which need to carry slowly , make fork parallel to the ground, lifting the fork to height, it can be inserted into the freight insert goods fork and move forward slowly, when the goods completely inserted into the goods after parking and stepping on the brakes, manipulating ascend handle, the heavy lifting to a certain height, make the door frame lean back, slowly astern, don't touch the adjacent goods, when weight completely left the heap of goods, reduce the goods to the right position, then walk for handling.

2). The weight on the heap of goods

Will weight low, lean back door frame, to storage goods moving close to the pile of deceleration, when determining forklift with pile goods into a linear state, stepping on the brakes slowly adjust the door frame Angle to the vertical state, increase the weight will be slightly more than goods pile height, and then slowly driving forklift driving forward to pile top stop. Heap controls control lever slowly, once handling stacked drags the weight, the goods fork

to the hollow position, from the weight of the goods fork, make sure barrier-free backward position, can retreat. After goods fork out weight reduce goods fork, door frame round of the reentry after handling operation.

9.Maintenance

The parts on the vehicle, especially safety devices, shall not be modified without permission, and the driving speed of the vehicle shall not be changed. All parts supplied by the original manufacturer are subject to strict quality inspection. To ensure the safety and reliability of the vehicle, please use the original accessories. Replacement parts, including all oil, must be collected and processed in accordance with local environmental and health laws and regulations.

9.1 Safety procedures for repair and maintenance

Maintenance technician: The maintenance and service should only be performed by special personnel trained by the manufacturer. After the technician sent by after-sales department of the manufacturer completed maintenance and servicing work, they should sign on the service log.

Cleaning Operation: Flammable liquid cannot be used for cleaning the stacker. Before cleaning, take safety precautions to prevent electric sparks (e.g. sparks caused by short circuit). When operating the accumulator, connectors on it must be disconnected. Use soft air suction or compressed air, non-conductive and anti-static brushes to clean electric and electronic components.

Operation of Electric System: Operation on the electric system should only be performed by specially trained personnel. Before performing any operation on the electric system, precautions must be made to prevent electric shock. When operating the accumulator, connectors on it must be disconnected.

Installation: When repairing or replacing hydraulic components, electric and electronic components, make sure to install them back to their original positions.

Wheels: Quality of the wheels has significant effect on stability and driving performance of the stacker. Modification on wheels can be performed only with the approval from the manufacturer. When replacing wheels, ensure that the stacker is levelled as delivery state (wheels must be replaced in pairs, i.e. replace right wheel together with left one).

Lifting chain and rollers: Chain and rollers will be worn quickly without good lubrication. Perform periodic lubrication according to following maintenance table. Shorten the lubrication period under adverse operation conditions (such as in dusty and hot environment).

Hydraulic oil pipe: The oil pipe must be changed every 6 years. When change the hydraulic assembled parts, the oil pipe should be also changed.

9.2 Daily Maintenance

9.2.1 Check every pole, every cable and their covers.

9.2.2 Check if the accumulator box is secured.

9.2.3 Check the stacker for oil leakage.

9.2.4 Check the chain, rollers, fork, oil pipes and horn.

9.2.5 Check the brake.

9.2.6 Check the wear and tear of drive wheels and loading wheels.

9.3 Professional Maintenance Manual

It is very important for safe operation of the truck to perform overall professional maintenance. Failure in performing maintenance according to specified interval may cause malfunction of the truck, and potential risk to human and equipment.

Maintenance periods listed in this manual apply to single shift a day under normal operation conditions. If using in dusty environment, the ambient temperature varies remarkably or in multi-shift situation, the maintenance period has to be shortened.

Maintain the truck according to following maintenance list. Maintenance periods are as follows:

W1 = Every 50 work hours, but at least once a week.

M3 = Every 500 work hours, but at least once every three months

M6 = Every 1000 work hours, but at least once every six months

M12 = Every 2000 work hours, but at least once every 12 months

Additional operations should be performed in trial run period:

(In initial 50 – 100 working hours or after two months)

— Check the nuts on the wheels, and tighten them if necessary.

— Check the hydraulic components for leakage, and tighten them if necessary.

— Replace the hydraulic filter.

Maintenance interval

| | | | W | A | B | C |
|----------------------|-----|--|---|---|---|---|
| Brake | 1.1 | Check the air gap of the electromagnetic brake | | | | |
| Electric system | 2.1 | Check the function of operation switch, display equipment and component | | | | |
| | 2.2 | Check alarm systems and safety devices | | | | |
| | 2.3 | Check the cable for damage. Whether the terminal is firm. | | | | |
| | 2.4 | Check the function of micro switch setting | | | | |
| | 2.5 | Check the controller and the EPS controller | | | | |
| | 2.6 | Cable and motor fixation | | | | |
| Power | 3.1 | Check battery | | | | |
| | 3.2 | Check the charging connector for battery | | | | |
| | 3.3 | Check whether the connection of the battery cable is tight, and smear the electrode with grease if necessary | | | | |
| Driving system | 4.1 | Check the gearbox for noise | | | | |
| | 4.2 | Check the driving mechanism and grease, check the reset function of the operating handle | | | | |
| | 4.3 | Check the drive wheels and bearing wheel for wear and damage | | | | |
| | 4.4 | Check wheel bearings and fixtures | | | | |
| Massive structure | 5.1 | Check the frame for damage | | | | |
| | 5.2 | Check the label for completeness | | | | |
| | 5.3 | Check the fixation status of lifting mast | | | | |
| The hydraulic system | 6.1 | Check the hydraulic system function | | | | |
| | 6.2 | Check that hoses, pipes, and joints are tight and that seals are not damaged | | | | |
| | 6.3 | Check cylinder and piston for damage, seal and fixation | | | | |
| | 6.4 | Check load chain Settings and re-tighten if necessary | | | | |
| | 6.5 | Visually inspect mast roller and inspect roller surface for wear | | | | |
| | 6.6 | Inspect cargo fork and load parts for wear | | | | |
| | 6.7 | Check oil level | | | | |
| | 6.8 | Renewed hydraulic oil | | | | |

9.4 Maintenance, Recharging and Replacement of the accumulator

The truck must be parked in a safe location before any operation on the accumulator.

9.4.1 Maintenance Technician

Battery charging, maintenance and replacement must be operated by qualified professionals. The user manual, supply preparation and charging requirements must be carefully read before the preparation operation.

9.4.2 Fire protection measures

When operating the battery, smoking and open flame are strictly prohibited. Storage batteries and charging should be kept away from combustible materials, and should be kept at least 2 meters away. Places where batteries are placed should be well ventilated and equipped with fire protection facilities.

9.4.3 Battery maintenance

- 1) Keep the nuts on every battery cell dry and clean. Tighten every terminal and cable end, and brush them with grease to prevent corrosion. Naked cable ends and terminal posts should be covered with a skid-proof insulating cover.
- 2) Every two cells should be well-connected. Check the nuts on each pole, if loose, tighten the nuts.
- 3) Keep the surfaces of accumulator clean and dry. After the completion of recharging, clean spilled acid with cotton yarns or brush. And clean with wet towel if necessary.
- 4) Over recharging and over discharging should be avoided, and fast charging and insufficient recharging are also not allowed. Otherwise life span of the accumulator may be affected.
- 5) Do not put conductive objects including metal tools on the accumulator, or short circuit or even explosion may be caused.
- 6) Never spill any hazardous liquid or solid material on surfaces of the accumulator. When using a densimeter or a thermometer, make sure the surface is clean and clear.
- 7) Recharge the discharged accumulator in time. Delayed recharging may damage the accumulator. Do not delay recharging more than 24 hours. Recharging of the accumulator may not work outdoors in cold weather. In this case, move it indoors to perform recharging.
- 8) If the accumulator will not be in use for a long time, it should be recharged and discharged once every month and it should be fully recharged every time.
- 9) During recharging or using, the liquid level of electrolyte lowers because of water evaporation, so pure water should be added. It is not allowed to add electrolyte with a specific weight of 1.280.
- 10) If individual cell fails, identify the cause and repair the cell immediately. Replace the cell when it cannot be repaired.
- 11) The site for recharging should be well ventilated. It is prohibited to smoke or use open fire, avoiding the risk of hydrogen explosion.
- 12) The electrolyte in accumulator is toxic and corrosive. For this reason, always wear working suit and protection glasses to protect your body from contacting the electrolyte in accumulator.

13) If your clothes, skin or eyes are spilled with acid liquid in accumulator, flush with large amount of clean water. For skin and eyes, flush with large amount of clean water and also seek doctor's treatment immediately. Acid spillage must be neutralized and treated immediately.

14) The weight and dimensions of the accumulator have remarkable effect on stability of the stacker. Therefore do not modify the type of accumulator without approval from the manufacturer.

15) Never discharge in large current, for example, performs travelling and lifting simultaneously.

9.4.4 Disposition of worn-out accumulators

Worn-out accumulators should be recycled according to local regulations, and stored in specified zone or cast-off treatment zone. These works should be done by qualified specialized companies.

9.4.5 Specification of the accumulator

| Battery | | Charger | |
|---------------------|-------------------------|------------------------------|---------------------|
| Rated power: 24V | Load capacity: 210Ah | Input: 195/265VAC 50/60Hz | Output: DC24V30A |

The battery's non-insulated terminal must be protected by an insulating cover. When the battery is connected and connected to the socket, the vehicle must be cut off and the switch in the closed position. When replacing or assembling the battery, make sure the battery is securely fixed in the battery box.

9.4.6 Storage, transportation and installation of the accumulator

The truck must be parked on the level ground steadily. To prevent short circuit, naked cable ends and the terminal posts should be covered with insulated covers. When pulling out the accumulator, properly arrange removed accumulator's connectors and cables without blocking access of the accumulator.

9.4.7 Battery power indicator

Battery power display table: ten article showing represent 100% of the battery. With the consumption of battery capacity, the glowing article shows will be from top to down.

The color of LED show the different states :

| Name | LED Color | |
|------|-----------|--|
| | | |

| | | |
|--------------------------------------|--------------|---------|
| The standard battery remaining power | Green | 70-100% |
| | Orange | 30-60% |
| | Red blinking | 0-20% |

Battery discharge on 70%, red lamp will blink “Energy storage”;

Battery discharge on 80%, two lamp will blink “run out of battery”, Must to the accumulator.

9.4.8 Charging

The Electric truck is supplied with a special charger for recharging.

Read the instruction manual carefully before recharging.

The batteries should be recharged in well-ventilated areas. Make sure no metal objects placed on the accumulator.

Check all cables connection and connectors for obvious defects. Observe strictly all safety instructions, e.g. replenishment of the accumulator and preparation for recharging.

For safety working, the truck should be added protective cover before using.

10.Safety Precautions

10.1 general rules

10.1.1 Operators must have the operation qualification of the truck (subject to the training approval of relevant departments).

10.1.2 Operators must read all the contents of the user manual before using, and can only drive it after fully understanding it.

10.1.3 The carrier shall not carry passengers.

10.1.4 Operators should pay special attention to the operating environment when operating, including other personnel nearby and fixed objects.

10.1.5 Do not modify, add or disassemble the moving parts without the manufacturer's approval, so as not to affect its performance.

10.2 Transportation and storage

10.2.1 When shipping in containers or cars, please note:

- ① The front and rear wheels are fixed with a wedge to prevent sliding during transportation.
- ② When using the lasso, pay attention not to put on the fragile structure of the moving vehicle;
- ③ When using the stacker, keep the center of gravity of the truck in the middle of the fork.
- ④ When using the stacker, keep the center of gravity between the two forks.



10.2.2 When the van is not working, it should be parked in a dry and ventilated garage to prevent the sun and rain, and please note:

- ① Turn off the electric lock, cut off the power and unplug the power plug;
- ② After pulling up the stationary truck, the front and rear wheels are well parked.

③ In case of long-term disuse, the battery should be replenished every 15 days.

10.3 Check before Using

10.3.1 If the new vehicle is damaged during transportation, please do not put it into use and contact the supplier in time for proper treatment.

10.3.2 New vehicles have been equipped with lubricating oil and hydraulic oil in the fuel tank.

10.3.3 Storage battery for the moving vehicle. The battery has been charged at the factory. If the factory is long, the power may be low. Attention should be paid to the display of the electric meter before use. When the electric meter is shown to the last two bars of warning, it must be charged immediately. Open the battery cover every day before use or before charging. Check the level. If the level is too low, distilled water should be added before charging. See (battery charging and maintenance) for details.

10.4 Safe Operation

10.4.1 Requirements for drivers: the vehicle must be operated by trained personnel;

10.4.2 Rights, obligations and duties of the driver: the driver must clarify his rights and obligations and have been trained in the operation of the vehicle; Be familiar with the operation manual. If the vehicle is pedestrian controlled, the driver must also wear safety boots while operating.

10.4.3 The use of unauthorized personnel shall be prohibited: the driver shall be responsible for the vehicle during the working period, and he must prevent the unauthorized personnel from driving or operating the vehicle. It is strictly prohibited to use vehicles to transport or lift personnel.

10.4.4 Faults and defects: the management must be notified immediately if the vehicle has a fault or defect. If the vehicle can't operate safely (e.g., wheels are worn down or brakes are faulty), then be sure to stop using them until they are fully repaired.

10.4.5 Safe operation and environmental protection: the contents of inspection and maintenance must be performed according to the time interval on the maintenance list.

The parts on the vehicle, especially safety devices, shall not be changed without permission, and the operating speed of the vehicle shall not be changed.

All the spare parts of the original factory have been verified by the quality assurance department. In order to ensure the safety and reliability of the vehicle operation, the spare parts of the manufacturer must be used only.

Replacement parts such as oil and fuel must be processed in accordance with the appropriate environmental protection rules.

10.4.6 Danger zone: the danger zone usually refers to the following areas: the area where the load lifting device (such as cargo fork or accessories) of the carrier is dangerous to the personnel during operation or lifting action, or the area where the load is being transported. Usually this range extends to the area where the payload or vehicle attachment lands.

Unauthorized personnel must be required to leave the danger area. As long as the person may cause some kind of injury, the driver must give the warning, if the driver asks him to leave but has not left the dangerous area, must stop immediately.

10.4.7 high-risk environment: when working in high-risk environment, special design must be adopted to protect it.

The car is not specifically designed for high-risk environments.

10.4.8 safety devices and warning signs: safety devices, warning signs and warning notices described in the operation manual must be given sufficient attention.

10.4.9 driving in public places: cars are prohibited from driving in public places except special areas.

10.4.10 distance between vehicles: keep in mind that the vehicle ahead may suddenly stop at any time, so keep a proper distance.

10.4.14 operation management: the driving speed must be adapted to local conditions. Vehicles must travel slowly when passing through curves, narrow passages, revolving doors, and in unobstructed areas. The driver must be able to visually detect sufficient braking distance between the vehicle and the vehicle in front of him, and he must always control his vehicle. It is not allowed to stop suddenly (unless urgent), turn in the opposite direction quickly, and chase each other in places where the passage is not open.

10.4.15 visibility: drivers must keep their eyes on the driving direction to ensure that the path ahead is clearly visible. When the vehicle retreats, the cargo is blocked from view and must be accompanied by a second person walking in front of the vehicle to give appropriate guidance and warning.

10.4.16 through ramps: only known ramps are allowed, and the ramps should be clean, non-skid and allowed by vehicle technical specifications. Heavy loads on cargo forks must face upward. Turning around, going sideways, or stopping at the same place on the ramp is not allowed. The ramp must be driven slowly and be ready to brake at all times.

10.4.17 ground load: please check whether the weight of body and load or the pressure of wheels on the ground exceeds the bearing capacity of the ground when the vehicle is working.

10.4.18 vehicle changes: any changes or changes that may affect the rated load, stability or safe operation of the vehicle shall be subject to prior written approval by the original manufacturer or its successor.

11.Repair Manual

11.1 Malfunction analysis

| Fault | cause | Processing method |
|--------------------------|---|--|
| The vehicle can't move | The battery connector is not connected | Check the battery connector , connected if necessary |
| | Electric lock switch on "0" | Electric lock switch turn right |
| | Emergency Stop Switch not open | Open the Emergency stop switch |
| | Battery power runs out | Check the battery charge , If it is necessary to recharge |
| | The truck being charge The fuse is damaged | Interrupt charging process Check the fuse |
| The goods cannot ascend | The truck no running | According to the "vehicle can not move" listed in the fault processing method of operation |
| | Less hydraulic oil | Check the hydraulic oil |
| | The fuse Is damaged | Check the fuse |
| | Over weight | Note the load capacity |
| | the micro switch of lifting contact is not good or damaged | Check the fuse |
| The goods can't drop | The dirty oil blocking control valve | Check the hydraulic oil and cleaning control valve, and if necessary change the hydraulic oil. |
| | Lowering solenoid valve no open or damaged | Check the lowering solenoid valve or change |
| Can't stop rising | Lifting micro switch damaged | Cut the power, change lifting micro switch |
| A direction moving | Micro switch and cable jumper contact is not good | Check the micro switch and connect Jumper witch on the control handle |
| The truck move slowing | Battery power shortage or homologous cable jumper contact is not good | Check the battery power led and homologous cable jumper contact. |
| The car suddenly started | Controller is damaged. | Change the controller |
| | The handle which control the forward or back is no reset. | Repair or change |

If above steps still cannot solve problems, please contact after-sales service department of the manufacturer and have the problems solved by specially trained technicians.

11.2 preparation work before repair

In order to prevent accidents that may occur during the repair and maintenance operation, the following preparations must be completed:

- park the vehicle safely.
- press the emergency stop switch to unplug the battery connector.

11.3 check the oil content of hydraulic oil

Prepare the vehicle for repair and maintenance.

Open the cover of the electrical box.

Check the amount of hydraulic oil in the oil tank.

When checking the hydraulic oil, the fork and frame must be lowered to the minimum.

11.4 preparation work before use after maintenance

The vehicle can only be used after the following operations have been completed.

-- clean the vehicle.

--check whether the brake function is normal.

- check whether the emergency stop switch function is normal.

-- check the horn for proper function.

Several electromagnetic brake tests will be conducted immediately after the test.