

EKKO[®]

MATERIAL HANDLING EQUIPMENT

MOVING **AHEAD**

COUNTERBALANCE STACKER EK14-130Li SERIES

- Load Capacity 3300 lbs.
- Lift Height 130" in.
- EPS (Elec. Power Steer)
- Length 105 in.
- Curtis Instrument Controller
- Tilt 2/5 degree
- Mast Height 84 in.
- Lithium Battery & Charger Included
- 3 Year Limited Warranty



EK14-130Li SERIES

Superior quality, maneuverable, compact, and durable for all your material handling applications. Ideal for small aisles and areas.

WEIGHT CAPACITY: 3300 lbs. @ 24" load center

LIFT HEIGHT: 130" (10.83ft)

FORK LENGTH: 45.3"

MAST HEIGHT: 84"

TURNING RADIUS: 62"

TILT: 2/5 degree

BATTERY / CHARGER: 24V/150AH-Lithium with external direct connect 110A 110VAC plug-in automatic 24V/50A charger (both Included)

BRAKING: Electromagnetic Brakes

SPEED TRAVEL: 3.7 mph empty ; 3.5 mph loaded

LIFTING SPEED: 5.5 ips empty; 4 ips loaded

LOWERING SPEED: 4.7 ips empty; 5.3 ips loaded

DRIVE WHEELS: 9.8" x 3" Polyurethane

LOAD WHEELS: (2) 9.8" x 4.7" Polyurethane

HYDRAULICS LIFTING MOTOR: 24V 3000 Watt lifting motor with hardened chrome moly steel for durability.

DRIVE MOTOR: 24V 2500-Watt German ZF AC drive motor for efficiency and high torque.

STEERING MOTOR: EPS (Electronic Power Steering) 24V 200 Watt

AC CONTROLLER: 24V CURTIS Instrument provides performance through entire range of speed; Constant travel speed regardless of load; Battery discharge indicator combination gauge.

BRAKES: Electro-magnetic braking for secure stopping power; Electronic neutral braking for accurate control.

OPERATOR CONTROLS: EPS (Electric Power Steering), tilt lifting, lowering, horn functions are located in the ergonomic handle; Belly button reverse safety feature allows the unit to stop and reverse to avoid collision or injury.

CHASSIS AND MAST: Robotic Welding; Heavy duty steel chassis with I-beam mast for durability; Telescoping mast.



Counterbalance Stacker

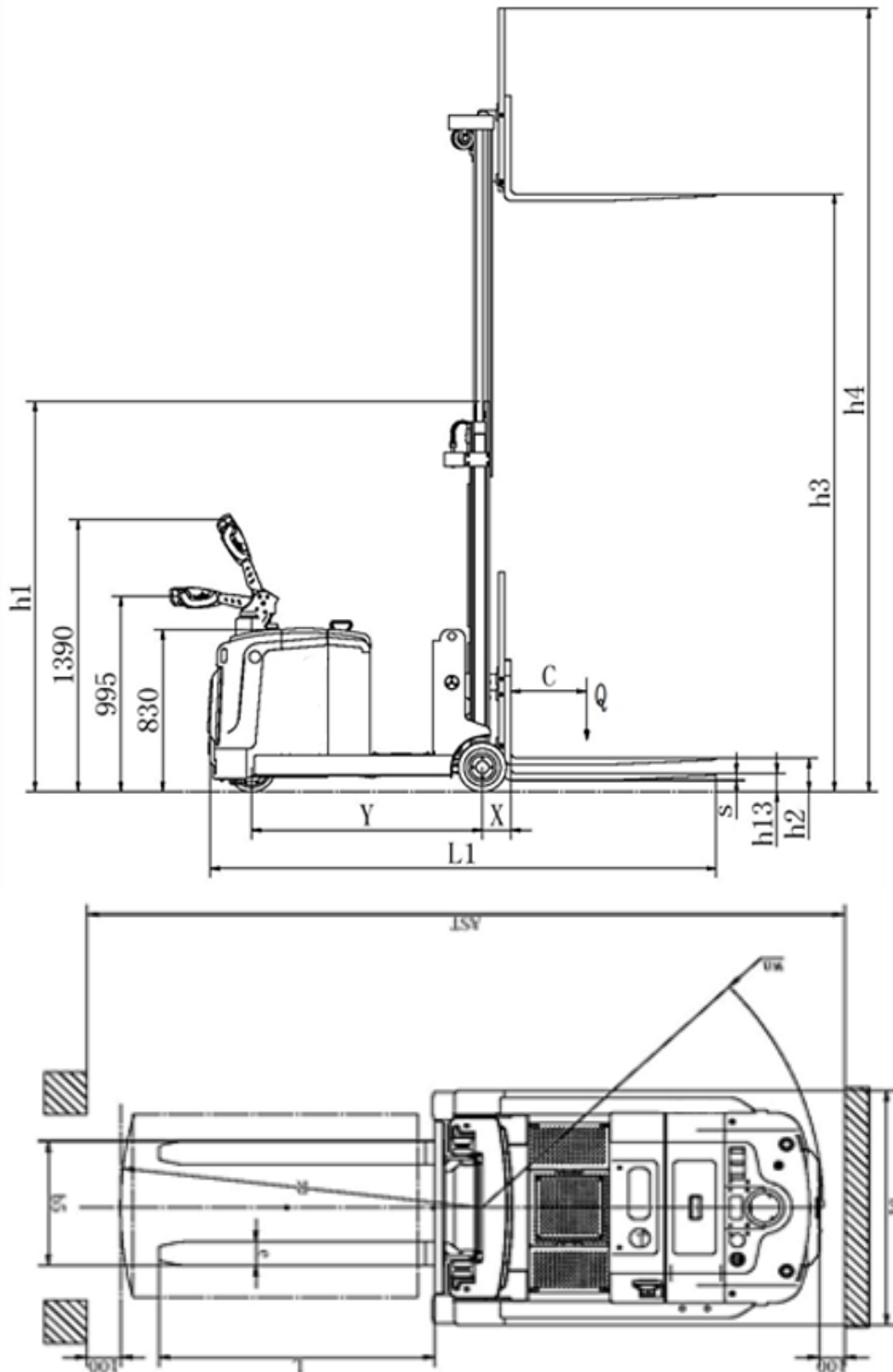

MODEL #	LOAD	MAST	LIFT HEIGHT	MAX MAST HEIGHT	TOTAL LENGTH	SERVICE WEIGHT
EK14-130Li	3300 lbs.	84"	130"	155"	105"	3750 lbs.



1761 W. Holt Ave. Pomona, CA
91768 USA T: (877) 232-6517
F: (909) 222-6861

AUTHORIZED DEALERS ONLY
www.ekkolifts.com