



Operation and Maintenance Manual

EK50LP ;10K Series



Liquid Propane Forklift

with Pattern Cushion Tires.



Foreword

1.1 Application Scope and Instruction on the Manual

- The manual contains the following contents: proper operation, easy maintenance and daily check;
- Before operation, please read the manual thoroughly to guarantee safe and effective material handling through proper operation and maintenance;
- Actual condition may be different from the description in the manual because of product improvement;
- The manual should be attached to the truck when lending or transferring the truck;
- If you have any questions, please consult with the sales department of our company;
- Instructions with  or  mark are very important to your and others safety, Please keep to them.

The OPERATION & MAINTENANCE MANUAL is delivered to you along with the truck. If there is no manual, please contact with local agent or dealer.

1.2 Safety signal, expression and mark

1.2.1

It indicates an imminently hazardous situation which, if not avoided, will result in death or serious injury. You must observe this instruction.



DANGER

1.2.2

It indicates a potentially hazardous situation which, if not avoided, could result in death or serious injury. You must observe this instruction.



WARNING

1.2.3

It indicates a potentially hazardous situation which, if not avoided, could result in minor or moderate injury. You must observe this instruction.



CAUTION

1.2.4

It indicates a statement of directly or indirectly related to the safety of personal and maintenance of the truck.



NOTE

1.3 Applied model

The manual is suitable for the following models:

- CPYD40,50C-PW2H with PSI 4.3 certified engine

1.4 Truck general view

1.4.1 Truck application

It is mainly used for load carrying.

1.4.2 Direction affirming

Direction in this manual is affirmed from the operator's seat.

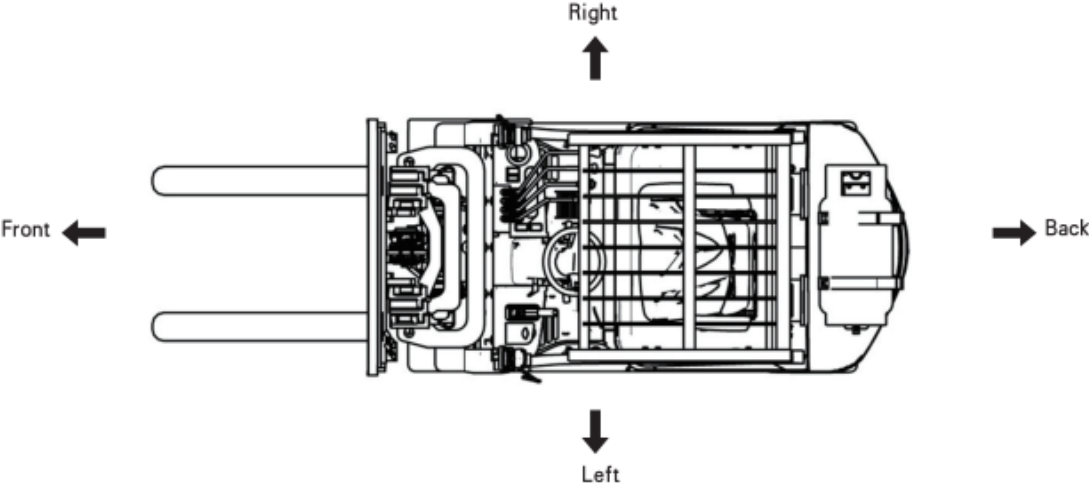

1.5 Measuring unit

The measuring units used in the manual are international system units(SI).

1.6 Operation certification



The truck can only be operated by trained and authorized person, or serious injury or death may be caused by operation by unqualified person.

1.7 Notes on new truck usage

1.7.1 Running-in of new truck

- Though the truck has experienced thoroughly adjust and test before delivery, the truck need moderate operation in the first month (200 hours) until all parts of the truck have full running-in time.
 - If the new truck works at bad environment at very first, the service life of the truck will be shortened and the performance will experience bad impact.
 - Pay attention to the following when the truck is run-in:
 - Keep the engine running at idle speed for 5 minutes after the engine is started;
 - Do not operate the truck when the truck is heavy loaded or travelling with high speed;
 - Avoid sudden start, acceleration, brake or sharp turning.
-

1.7.2 Maintenance of the new truck

The new truck needs oil changing, oil filter cleaning and bolts and nuts retightening during the first month usage (200 hours). EKKO vehicles are to be maintained by EKKO dealers.

1.8 Quality guarantee and maintenance

1.8.1 Parts changing at regular time

EKKO trucks require parts changing at regular time except for the legal rules. Parts which are important for safety will inescapably go bad if they exceed their service time, so whether the parts are damaged, change according to regulated time. Refer to 4.14 CHECK and MAINTENANCE TABLE for the key parts changing.

1.8.2 usage of EKKO specified parts and oil

Problems caused by the usage of non-EKKO specified parts (including oil) are not covered by our warranty.

1.9 Basic information of the truck

Please offer EKKO dealers or agents the basic information of the truck such as a model, truck number, engine series number, accessories, optional devices and so one when maintaining the truck or ordering parts.

1.9.1 Truck basic information table

Model	
Truck number	
Engine series number	
Accessories, optional devices	
Dealer/agent	
Address	
Telephone number, fax number	
Service person	
Sales person	

1.9.2 Displaying position of the truck model and number

The truck model and number is displayed on the truck plate which is on the right side of the engine hood.

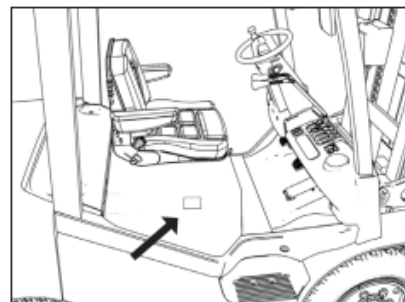

WARNING
IMPROPER OPERATION OR MAINTENANCE
COULD RESULT IN INJURY OR DEATH

MODEL NO. _____ SERIAL NO. _____

ATTACHMENTS _____

CAPACITY WITH ATTACH LISTED ABOVE OR WITH FORKS-UPRIGHTS VERTICAL				
A (in)	B (in)	C (in)	D (in)	lbs

APPROX. WT. lbs _____ ENGINE TRUCK _____

FOR OTHER CAPACITIES CONSULT MANUFACTURER
AS SHIPPED FROM THE FACTORY, THIS TRUCK CONFORMS TO ADR16105:1

Model description

Truck information

Mast information

Truck service weight

Brand information

Model description shows the classification of industrial truck and manufacturer. Truck information includes truck type, serial number. Service weight means the truck weight with standard configuration. Mast information consists the truck model assembled with the mast, mast type and height (M stands for two stage basic type mast, ZM stands for full free two stage mast, ZSM stands for the full free three stage mast. The unit is cm.) Attachments consists types of side shifter, rotator, bale clamps and so on. Please refer to the attachments manual for more details such as model and function. Pay attention that the rated lifting capacity refers to the capacity of the truck with standard mast, standard fork and 24in load center and without any attachments. Brand information includes manufacturer and whether the product meets Europe CE certification.

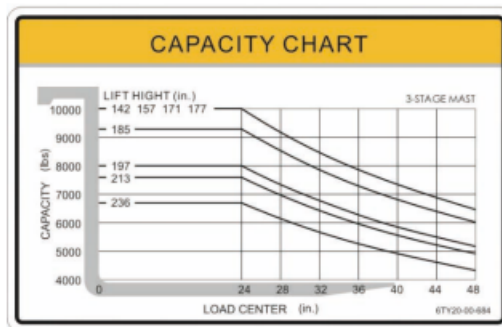
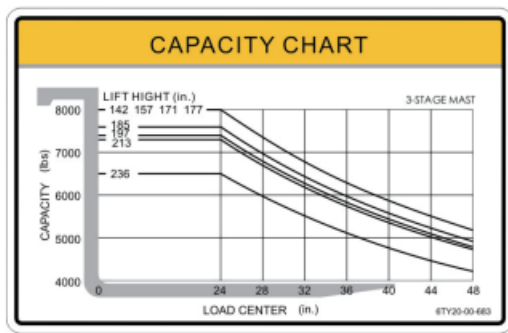

Completed truck actual capacity is related to attachment, load center and lifting height. Please refer to the figure above.

The truck number is also shown on the external plate of the truck.

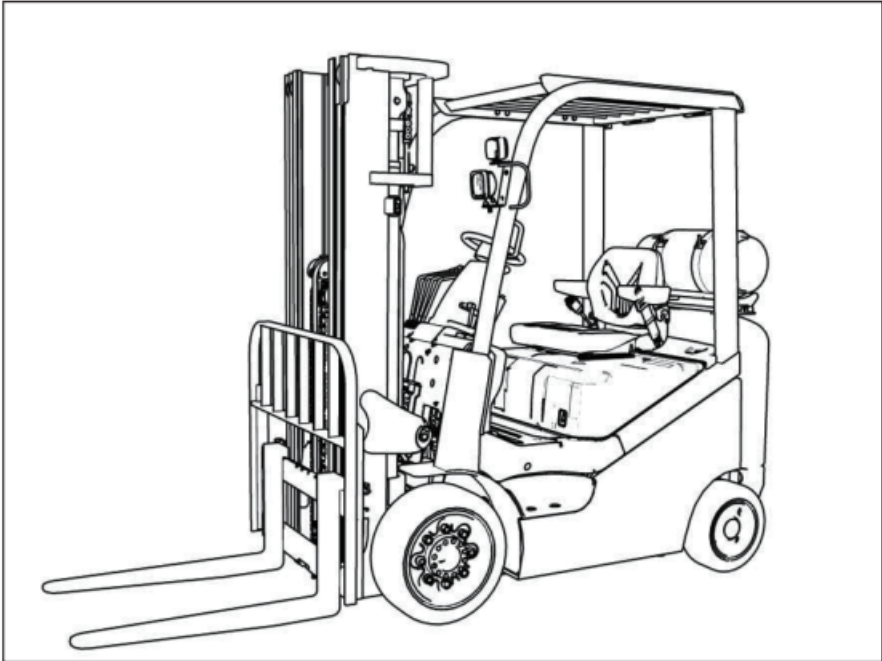

1.9.3 Displaying position of the truck working hours

It is in the middle of the meter.

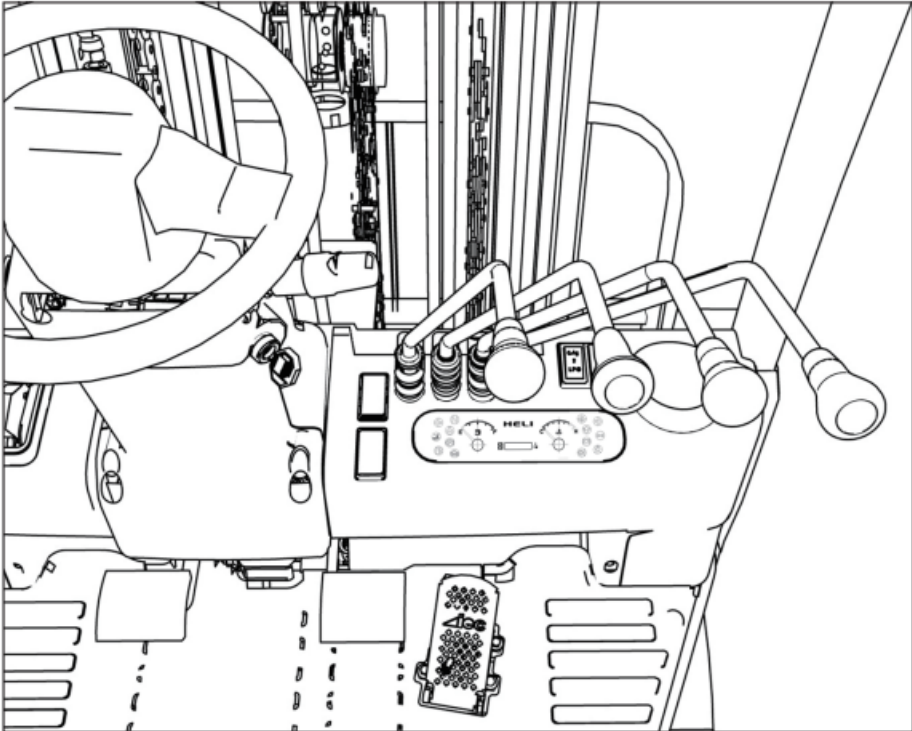

CONTENTS

FOREWORD **01**

1.1 Application Scope and Instruction on the Manual.....	1
1.2 Safety signal, expression and mark.....	2
1.3 Applied mode.....	3
1.4 Truck general view.....	4
1.4.1 Truck application.....	4
1.4.2 Direction affirming.....	4
1.5 Measuring unit.....	4
1.6 Operation certification.....	4
1.7 Notes on new truck usage.....	5
1.7.1 Running-in of new truck.....	5
1.7.2 Maintenance of the new truck.....	5
1.8 Quality guarantee and maintenance.....	5
1.8.1 Parts changing at regular time.....	5
1.8.2 Usage of EKKO specified parts and oil.....	5
1.9 Basic information of the truck.....	5
1.9.1 Truck basic information table.....	6
1.9.2 Displaying position of the truck model and number.....	6
1.9.3 Displaying position of the truck working hour.....	8

CONTENTS **09**

DESIGN DRAWINGS **15**

SAFETY NOTES **19**

2.1 Description of the safety plate.....	20
2.1.1 Position of the safety plates.....	20
2.1.2 Safety plates.....	21
2.2 Protecting against fire.....	24
2.2.1 Protect engine against fire.....	24

2.2.2	Protecting against fire caused by fuel or oil.....	26
2.2.3	Protect against fire caused by adhered flammable things.....	26
2.2.4	Protect against fire caused by wire fault.....	26
2.2.5	Protect against fire caused by oil pipe fault.....	26
2.2.6	Cleaning after operation.....	27
2.2.7	If fire occurs.....	28
2.3	Basic notes.....	28
2.3.1	Follow the rules.....	28
2.3.2	Do not operate fault truck.....	28
2.3.3	Proper wearing when operation	29
2.3.4	Fire extinguisher and first-aid kit.....	29
2.3.5	Note on the safety devices.....	29
2.3.6	Practice before operation.....	29
2.3.7	It is prohibited to jump on and off the truck.....	30
2.3.8	Keep the driver’s cab clean and tidy.....	30
2.3.9	Notes when flushing truck	30
2.3.10	Beware of scalding.....	31
2.3.11	Protection against fire.....	31
2.3.12	If fire occurs.....	32
2.3.13	Do not modify the truck.....	32
2.3.14	Do not disassemble overhead guard and backrest.....	32
2.3.15	Ensure the working area safety.....	33
2.3.16	Beware of the engine exhausting.....	33
2.4	Before operation.....	34
2.4.1	Starting check.....	34
2.4.2	Check and adjust before starting.....	34
2.4.3	Starting check.....	34
2.5	Travelling.....	35
2.5.1	Preparation before travelling	35
2.5.2	Notes when travelling.....	36
2.5.3	Notes on truck stopping and parking.....	41
2.5.4	Notes on towing.....	42
2.6	Load carrying operation.....	42
2.7	Check and maintenance notes.....	47
2.7.1	Be sure to carry out the starting check.....	47

2.7.2	Place a warning sign around during check and maintenance.....	47
2.7.3	Keep the working area clean and tidy.....	48
2.7.4	Notes before check and maintenance.....	48
2.7.5	Let the unauthorized people be away.....	48
2.7.6	Proper using of the tools and devices.....	48
2.7.7	Notes when working under the working devices.....	49
2.7.8	Beware not to be caught by mast or falling.....	49
2.7.9	Beware of the boiling cooling liquid.....	50
2.7.10	Take care of the high pressure oil.....	50
2.7.11	Beware of the rotating belt and fan.....	51
2.7.12	Notes when repairing electric system.....	51
2.7.13	Notes when cleaning with compressed air.....	51
2.7.14	Notes when dealing with battery.....	52
2.7.15	Follow the rules strictly so as to avoid spark.....	52
2.7.16	Note when installing or removing the battery.....	53
2.7.17	Note when dealing with the tyres.....	53
2.7.18	Note when dealing with the waste.....	54
2.7.19	Notes after check and repair.....	54
2.7.20	Regular check on the key parts.....	54
2.8	Transportation and hanging up.....	55
2.8.1	Notes when hanging up truck.....	55
2.8.2	Notes when loading or unloading the truck.....	55
2.9	Truck structure and stability.....	56
2.9.1	Longitudinal stability.....	56
2.9.2	Load center of gravity.....	56
2.9.3	Combined center of gravity and loaded truck stability.....	56
2.9.4	Actual loading capacity	57
2.9.5	Instruction on the capacity chart.....	57
2.9.6	Instruction on safety devices choice.....	58
2.10	Towing.....	59

OPERATON **60**

3.1	General view.....	61
3.1.1	Truck general view.....	61
3.1.2	Instrument and control devices.....	62

3.2	Parts instruction.....	63
3.2.1	Meter.....	63
3.2.2	Imported LPG cylinder	66
3.2.3	Operating devices.....	67
3.2.4	Assembly and disassembly of the attachments.....	71
3.3	Operation.....	73
3.3.1	Starting check.....	73
3.3.2	Getting on and off the truck and operation posture adjusting.....	73
3.3.3	Starting, gear shifting and travelling.....	76
3.3.4	Start and stop on a slope.....	84
3.3.5	Inching.....	85
3.3.6	Steering.....	85
3.3.7	Operate on snow field and icy field.....	86
3.3.8	Truck deceleration and braking.....	86
3.3.9	Fuel changing (double fuel truck model).....	87
3.3.10	Load handling operation	91
3.3.11	LPG charging	93
3.3.12	Check after operation.....	97
3.4	Transporting.....	98
3.4.1	Truck fixing.....	98
3.4.2	Mast transporting and reassembling	100

CHECKING AND MAINTENANCE

102

4.1	About checking and maintenance.....	103
4.2	Check before start	103
4.2.1	Check the abnormal found the day before.....	105
4.2.2	Forklift truck.....	105
4.2.3	Open the engine hood to check.....	108
4.2.4	Check sitting on the chair.....	111
4.2.5	Check when the starting key switch is on ON position.....	113
4.2.6	Check when the engine is started.....	116
4.2.7	Check when travelling slowly.....	118
4.2.8	Check through operating the working devices operation lever.....	118
4.2.9	Safety function check.....	120

4.3 Check after operation and report.....	121
4.4 Simple maintenance.....	122
4.4.1 Lubricating grease and fuel.....	122
4.4.1.1 Notes.....	122
4.4.1.2 Lubricating chart.....	124
4.4.2 Filter element cleaning.....	126
4.4.3 Vaporizer check and tar remove.....	126
4.4.4 Tyre changing	127
4.4.5 Parking brake shank operation force adjusting	129
4.4.6 Fuse changing.....	130
4.4.7 Bulbs changing.....	133
4.5 Steps of dealing with the fault battery.....	134
4.6 Working in cold weather.....	136
4.7 Measures for engine over heating.....	137
4.8 Operate truck in special environment or with force.....	138
4.9 Measures if the fork can not be lowered.....	139
4.10 Truck cleaning.....	140
4.11 Storing for a long time	141
4.12 slinging the truck	142
4.13 Loading and unloading the truck.....	143
4.14 Check and maintenance time table	144
4.15 Change the safety key parts regularly.....	154
4.16 Repair parameter	155

OPTIONAL

156

DESIGN DRAWINGS

A. General view of the truck

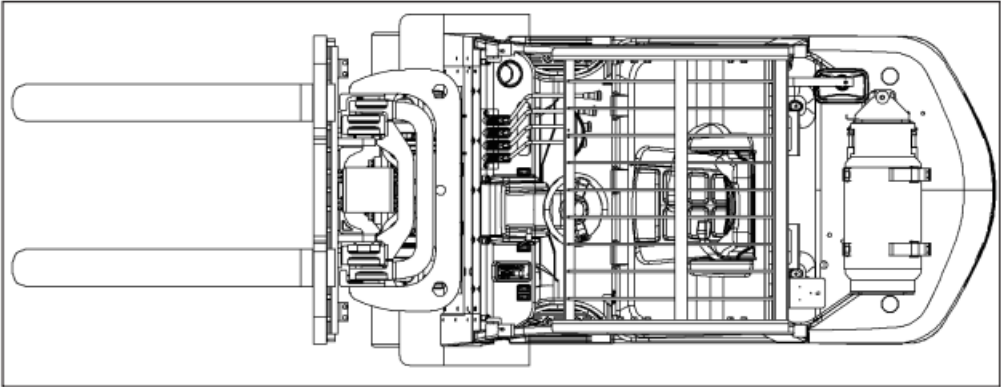
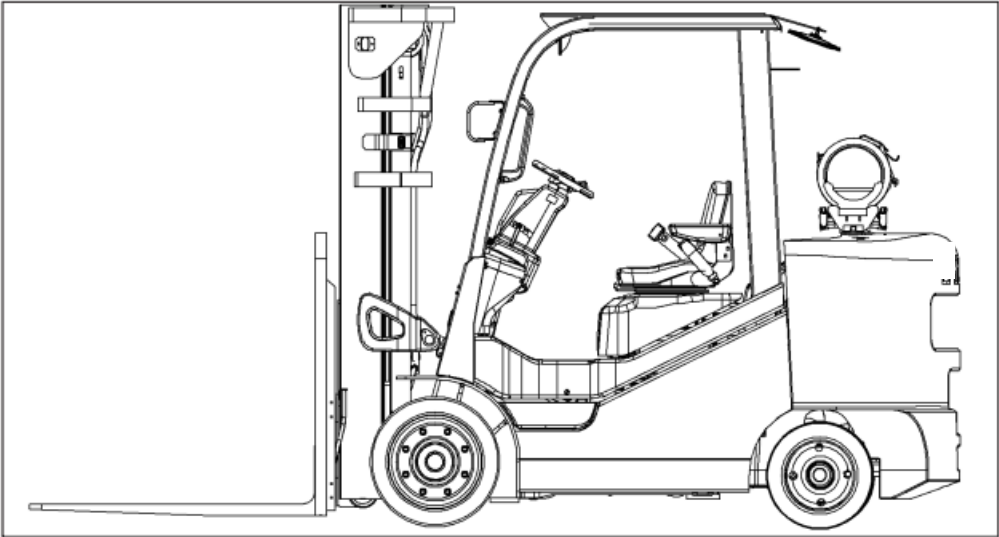



B. Electric principle diagram

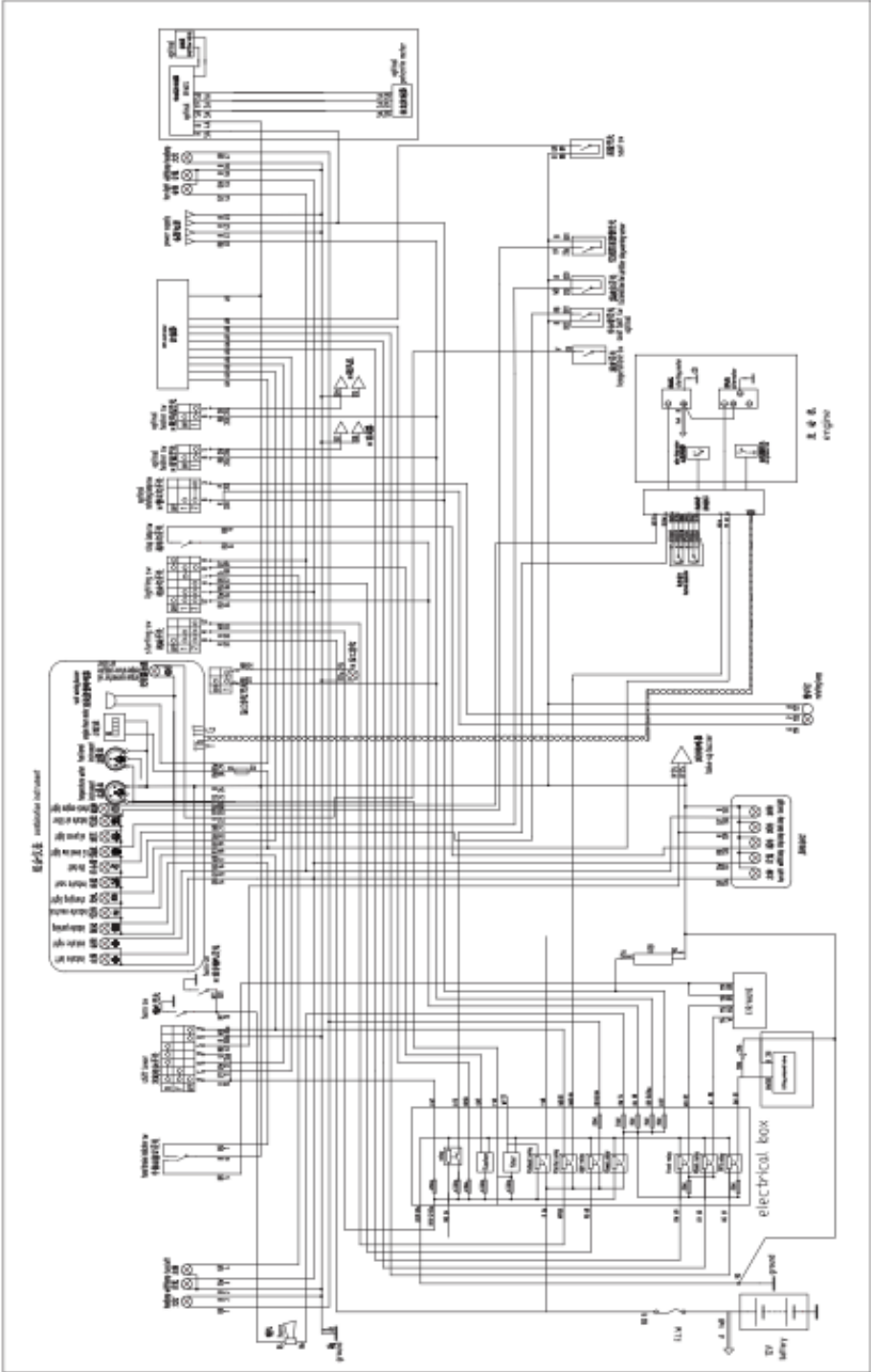

C. Principle diagram of hydraulic system

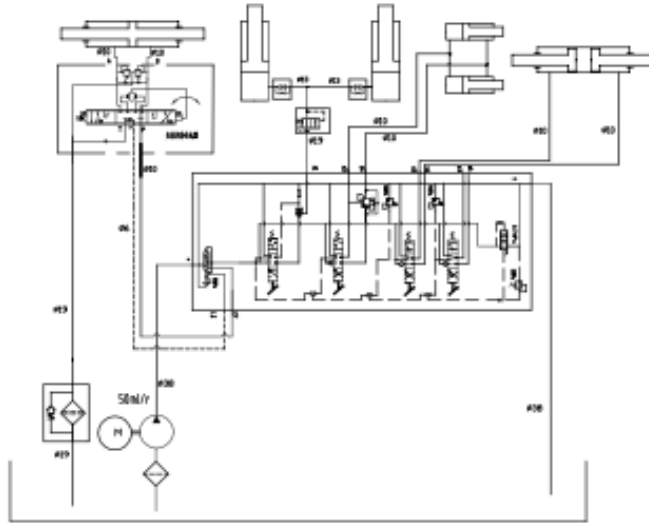

Principle diagram of hydraulic system

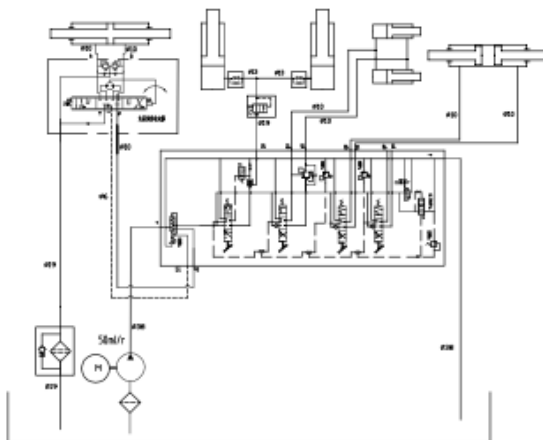

Principle diagram of hydraulic system

D. Principle of brake system

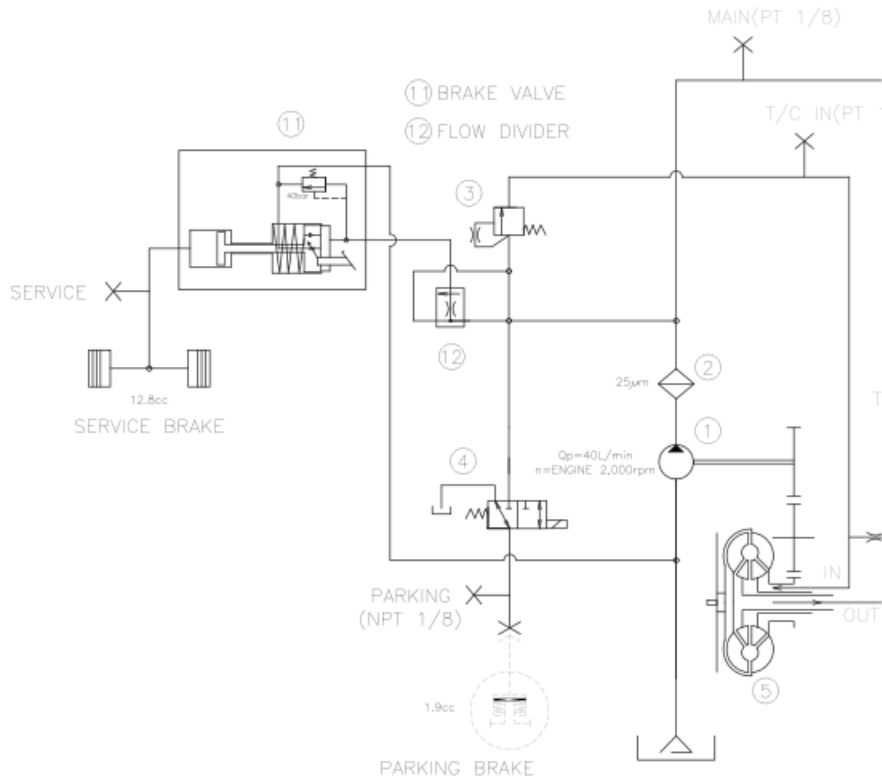

- ① CHARGING PUMP
- ② OIL FILTER
- ③ MAIN RELIEF VALVE
- ④ PARKING SOLENOID VALVE

SAFETY NOTES

 **WARNING**

Please read the manual and safety notes carefully.
When operating the truck, please follow the safety notes or serious injuries may be caused.



2.1 Description of the safety plate

2.1.1 Position of the safety plates

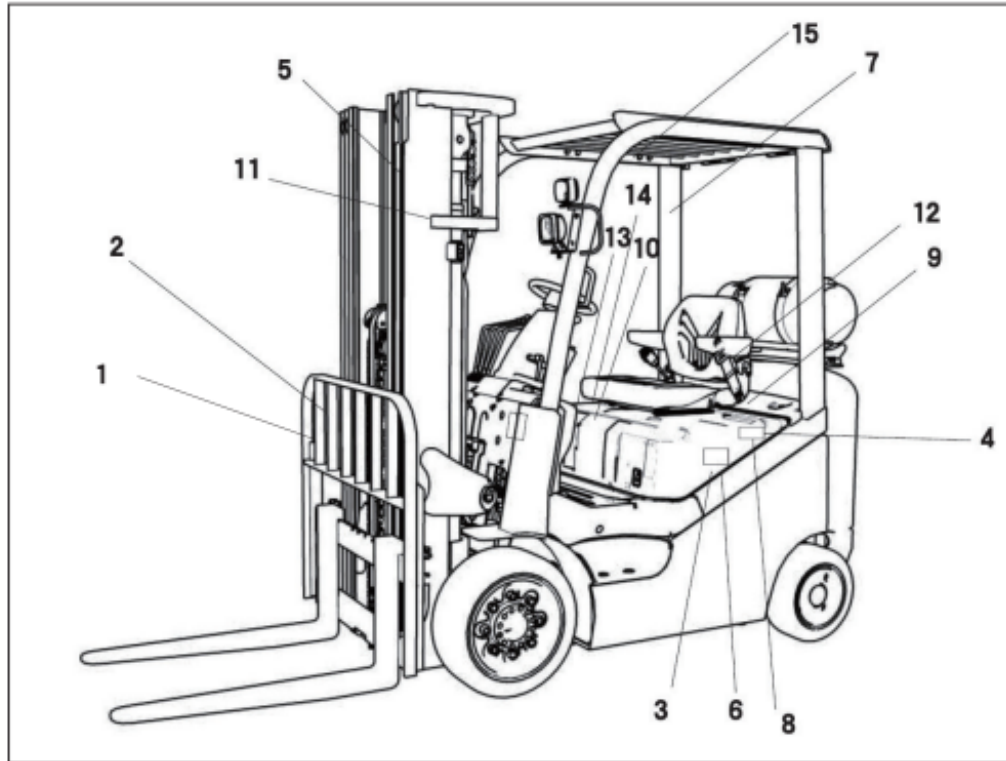

	Safety plate	Position
1	Mind your hands	The rear side of the tilting cylinder mast pillar and top pillar (the middle cross beam of the external mast)
2	Do not enter the space after the mast	The rear side of the tilting cylinder mast pillar and top pillar (the middle cross beam of the external mast)
3	Battery maintenance notes	In the middle of the battery external side
4	Checking points before starting (if there is no the plate, please refer to the usage notes)	The left side of the engine hood surface
5	Sling plate	The right and left side of the external mast
6	Gas spring safe lock	The outside of the left engine hood
7	No flushing water	The outside of the overhead guard right rear leg
8	Fan safety plate	The top of the radiator's wind cover
9	Aluminum radiator warning plate	the radiator's cover
10	Usage note	Right side of the engine hood
11	Safety plate	The right and left side of the external mast
12	Safety belt	The left side of the engine hood surface
13	LPG Safety maintenance notes	Right side of the engine hood surface
14	LPG cylinder changing notes	Right side of the engine hood surface
15	B56.1 safety mark	Right inner side of the overhead guond

■ (2) No jump starting

- Start the engine only when the operator sit well on the seat;
- Never try to make the engine starting circuit short circuit on purpose to start the engine, or serious injury or fire may be caused.



■ (3) Notes when dealing with battery

- The shape and layout may vary from different battery suppliers.
- Do according to the battery maintenance note during usage.

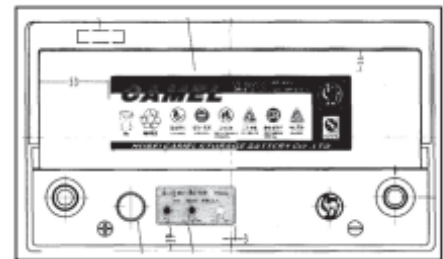

■(4) It is prohibited to enter the space between mast and frame.

- It is prohibited to enter the space between mast and frame.



■ (5) Notes when slinging

- Never sling the truck at the overhead guard top cover.
- Sling the truck at the shown positions.

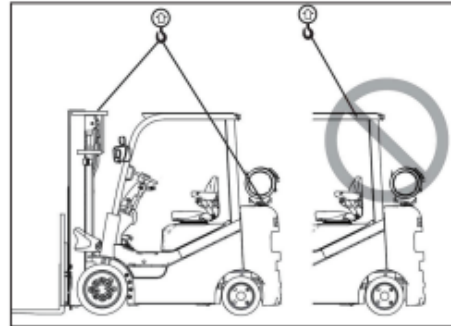

■ (6) Safe usage of the gas spring

- Please press the gas spring safe lock button before shut off the engine hood.

■ (7) Truck washing notes

- Do not flush the electric parts such as cabinet, sensors, connectors and so on.
- It is prohibited to flush the air intake cover of the overhead guard.



■ (8) Be care of cut

- Keep your hand away from the working fan.

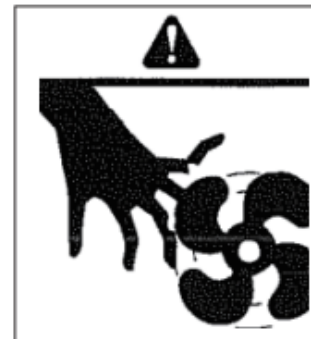

■ (9) Use the radiator with care

- Rotate the radiator cap slowly until the coolant is cool.



■ (10) Notes before operation

- WARNING: Read the OPERATION AND MAINTENANCE MANUAL carefully before operation, maintenance, disassembling and assembling.
- Read the usage note plate to avoid improper operation.
- Check the truck before starting according to the checking points before starting. (if there is no the plate, please refer to the usage notes.)



■ (11) It is prohibited to stay at the area above or below the fork.

- Do not enter the area below the fork.
- Do not stay on the fork.



■ (12) Take care of truck tipping over

- Before operation:
 1. Wear safety belt when operating;
 2. Be sure to read and understand what is said in OPERATION AND MAINTENANCE MANUAL;
 - If there is a possibility of tipping over during operation
 1. Do not jump off the truck;
 2. Body incline opposite the truck tipping over direction;
 3. Grasp the steering wheel tightly;
 4. Support your body with two feet.

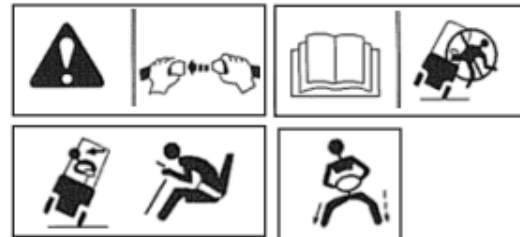

■ (13) Operate with proper posture

- If the truck is operated with such posture (the seat does not bear your whole weight, for example stand or lean against forward, backward or side when operating), the power will be cut for 3 seconds and in that case, the truck will not travel or operate.

It is very dangerous to operate like this when travelling on a slope. The truck will slide down even acceleration pedal is pressed because the power is cut. Accident such as collision or falling will occur.



2.2 Protecting against fire

2.2.1 Protect engine against fire

Before starting the engine, check the following parts: if the battery terminal is loose, fix it. And if there is dirt such as smudginess, leaf or paper, remove it.
If problems still exist, contact with HELI dealer for repair.

- 1. Check around engine
 - Check if there is any leaves or paper around engine;
 - Check if there is engine oil or fuel leakage around engine;
 - Check if the muffler and air exhaust pipe are well;

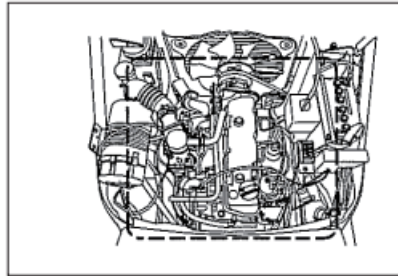

- Check if the wire and wire clamps are loose or damage.

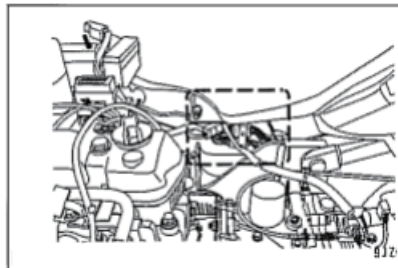

- 2. Check around the battery
 - Check if the battery terminal, contactors or wire clamps are loose or rust;
 - Check if there are leaves, paper or metal around battery;
 - Check if the cables or harness are damaged.

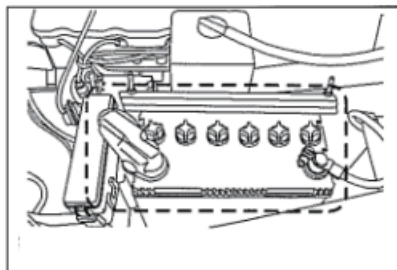

■3.Check if oil or LPG leaks

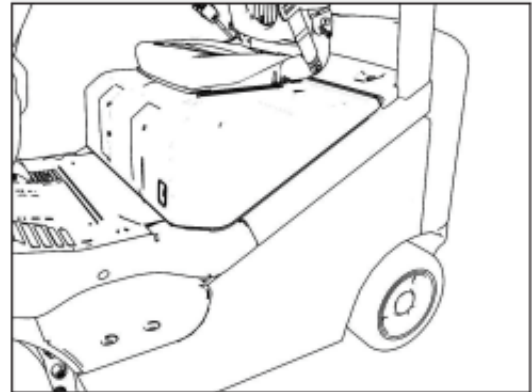

- Check if there are leaves or paper around fuel tank or hydraulic oil tank;

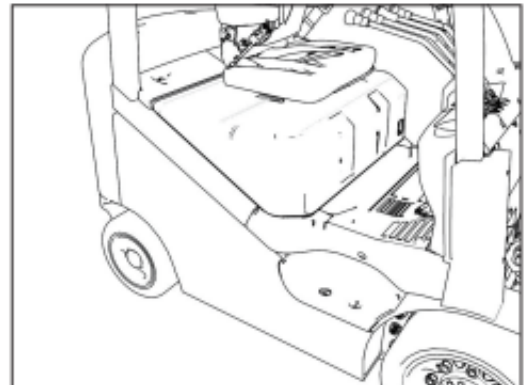

- Check if there are dirt gathering under the truck chassis (engine or transmission system), especially the truck with floor board.

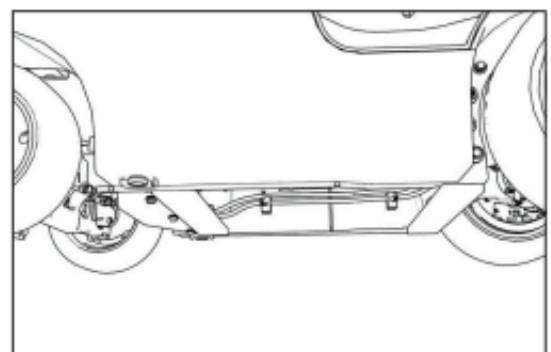

2.2.2 Protecting against fire caused by fuel or oil

■ Keep the fuel, oil, cooling liquid and window washing solution which are flammable away from the open flame. Obey the following instruction in actual operation;

- Do not smoke or keep the fire near the fuel, oil, cooling liquid or wind washing solution and clothes sucked with these liquid;
- Shut off the engine before fuel adding;
- Do not go away when oil or fuel adding;
- Tighten the oil adding cap;
- Do not let the fuel run out onto the hot surface or electric parts;
- Keep the fuel and oil in well ventilated shaded place;
- Keep the fuel and oil in specified place away from people;
- Remove the spilled fuel, oil and grease after oil adding;
- Keep the clothes sucked with oil and other flammable things in a safe container and store in a specified safe place;
- When checking or maintaining the truck with devices and equipments, take care and protection measures of the fire caused by spark or flame.

Serious injuries or death will be caused if these safety measures are not obeyed.

2.2.3 Protect against fire caused by adhered flammable things

■ Adhering or blocking of flammable thing around engine air exhausting manifold, muffler, air exhausting pipe, battery and inside of floor board will cause fire. Remove these flammable things.

2.2.4 Protect against fire caused by wire fault

- Fire will be caused by short circuit of wire.
- Clean all wire contactors and fix them;

The damaged harness must be repaired or changed by an EKKO dealer or agent.

2.2.5 Protect against fire caused by oil pipe fault

■ Be sure the snap clip, guard board and cushion pad are proper fixed. Loose pipe or hose may be damaged because of vibration or friction with other parts when operated and fire or injury may be caused by ejection of high pressure liquid.

2.2.6 Cleaning after operation

- Remove the dirt, leaves or paper with fan after operation.

- Around engine
Clean around air exhausting manifold.

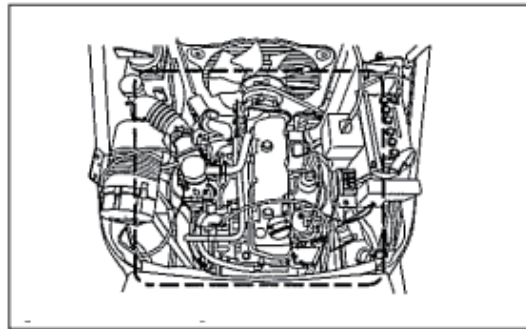

- The bottom of the chassis
Lay emphasis on the truck with bottom plate where dirt is easy to gather.

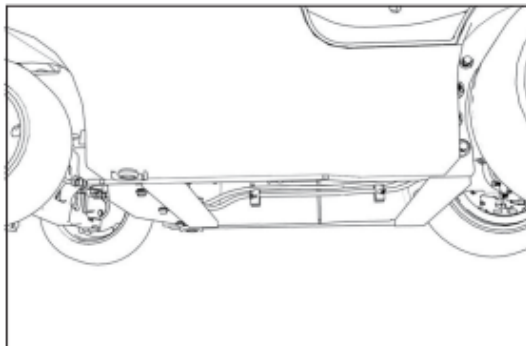

- Floor board



- Around the muffler

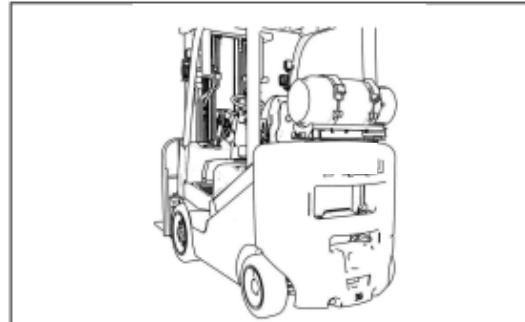

2.2.7 If fire occurs

- If fire occurs, turn the starting switch to OFF position to shut off engine.
- Do not jump off the truck in a hurry. Support yourself with handle and pedal in order to leave safely.

2.3 Basic notes

2.3.1 Follow the rules

- Only trained and authorized person can operate the truck.
- Fully understand and obey the OPERATION AND MAINTENANCE MANUAL.
- Do not operate the truck when you have tired, mix emotional problems, drugs or alcohol.

- Make a safety plan in advance.
 - Before operation, make operation plan according to the working environment, truck type, truck capacity and road condition.
 - Assign a towerman and operate according to his guide when travelling in a narrow place or loading or unloading big goods.
 - The main responsibility during operation is safety. Ensure the safety of yourself, truck, place around working and other property in the working area.

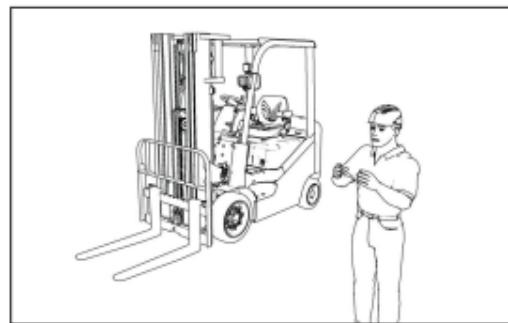

2.3.2 Do not operate fault truck

- If there is any abnormal during check or operation (such as noise, vibration, smell, abnormal of meter, smoking, miss-working of alarming device and monitor), report it to manager and take proper measures.
- Do not operate the truck until it is repaired.
- Remove the key from the fault truck and place a mark in the cab avoiding miss-using.
- If the truck with the fork lifted has to be stopped because of fault, place a mark on the fork and take measures preventing touch by pedestrian and truck.
- Place the truck where no person or truck will pass by avoiding person going under the fork.

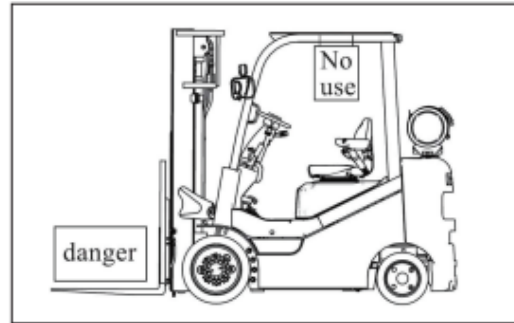

2.3.3 Proper wearing when operation

- Do not wear loose clothes and fittings. It is very dangerous if it is caught by control lever or other protrusions.
- Do up long hair or it may be caught by rotating parts.
- Wear safety cap and shoes. Wear equipments fits working condition or requirements.
- Before operation, check if the safety equipments are well.

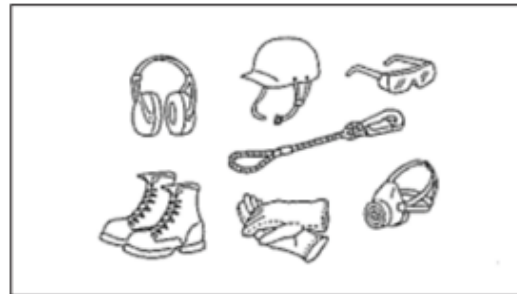

2.3.4 Fire extinguisher and first-aid kit

- Be aware of the position of fire extinguisher and first aid kit and know how to use then in case of fire or injury.



2.3.5 Note on the safety devices

- Check if the protection cover, shield and back mirror are proper fixed.
- Make sure you know the usage of safety devices fully.
- Do not disassemble the safety devices and make sure they are in good condition.

If there is damage or loose of overhead guard or back rest, do not operate the truck until EKKO dealer or agent fix it well.

2.3.6 Practice before operation

- Before operation, learn with enough time until all parts are familiar.
- Take care when driving even you are familiar with the truck or injuries or damage may occur.
- Truck even in same model has its own character in brake, accelerator and load handing device and so on. Before operation, be familiar with the truck if you change a new one. Take care when braking.

2.3.7 It is prohibited to jump on and off the truck

- It is prohibited to jump on and off the truck.
- Do not jump onto the truck to try to stop it when it moves accidentally without any operation.
- Get on or off the truck from the left side.
- Support yourself at least in three points with hand and foot when getting on or off the truck. Step on the step, grasp the handle with left hand and grip the seat back or seat when getting on and off.
- Do not grasp control lever and steering wheel when getting on or off the truck.

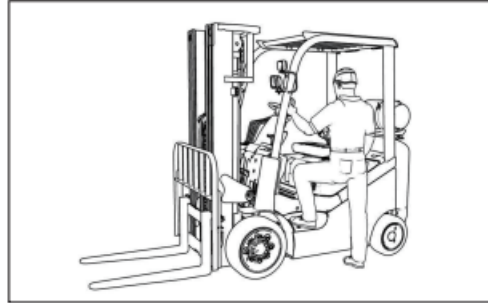

2.3.8 Keep the driving area clean and tidy

- Keep the driving area and area such as handle, step and floor board clean and tidy. Oil, mud, dust adhering around driving area or parts scattering around may cause slipping or fabric caught in which will cause accidental falling or miss-operation.

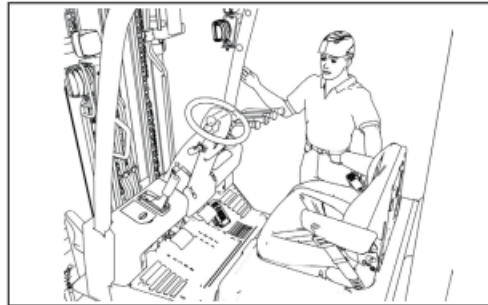

2.3.9 Notes when flushing truck

- Do not flush the electric parts (controller, sensor and contactor) or fault may occur. Or flush the truck with high pressure washer (steam washer).

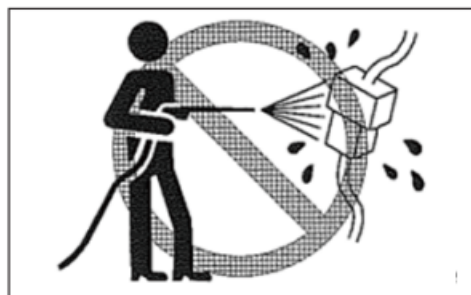

2.3.10 Beware of scalding

- Cooling liquid with high temperature
 - The cooling liquid is in high temperature if the truck is just stop. There is a danger of scalding caused by the ejecting of steam or boiling water if the radiator cap is removed at once. Remove the radiator cap slowly after the cooling liquid is cool.



- Parts and oil with high temperature
 - Check and maintain the truck until it is cool in order to preventing scalding by oil ejecting from the high temperature parts.



2.3.11 Protection against fire

- Protect against fire caused by fuel and oil;
- Protect against fire caused by adhered flammable things;
- Protect against fire caused by wire fault;
- Protect against fire caused by pipeline fault;



2.3.12 If fire occurs

- If fire occurs, turn the starting switch to OFF position to shut off engine.
 - Do not jump off the truck in a hurry. Support yourself with handle and pedal in order to leave safely.
-

2.3.13 Do not modify the truck

- Contact with EKKO sales and service agent before carrying out any modification (fix, disassembly and change) on the truck, accessories, optional parts because accidents or illegal occasion may happen.
- We are not responsible for any injuries, damages and accidents caused by unauthorized modify by EKKO.

2.3.14 Do not disassemble overhead guard and backrest

- The overhead guard and backrest are used to protect operators against harm from falling goods. Do not disassemble overhead guard and backrest.
- Do not operate the truck without overhead guard and backrest.
- The overhead guard is made according to the safety standard, but it may not satisfy with any occasion. Beware of the harm caused by the falling goods.

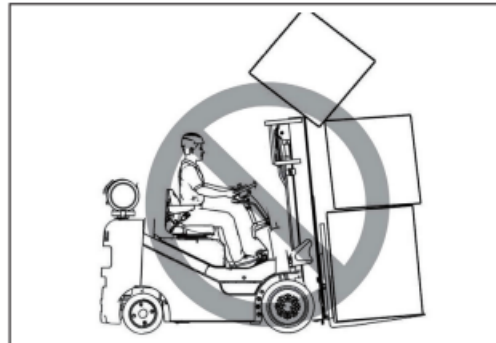

2.3.15 Ensure the working area safety

- Ensure the flatness of the road and working area and clean the oil and grease on the working area avoiding injury caused by bump and slip.
- When working in place that has a danger of falling such as dock, platform and so on, place blocks avoiding truck travelling surpassing boarder.
- Place a warning in dangerous place in working area to warn the drivers stay away.
- Identify the limit speed, temporary parking line and no entering of other vehicles and pedestrian and such plate clearly in working area.

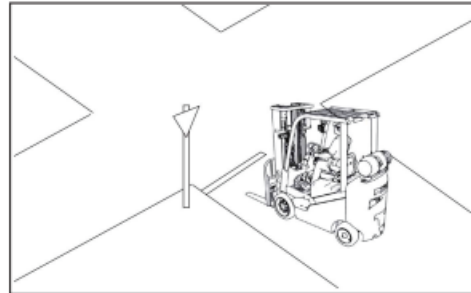
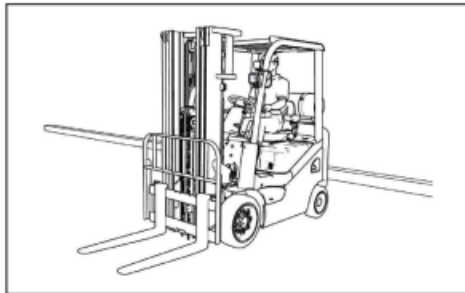

2.3.16 Beware of the engine exhausting

- The engine exhausting has carbon monoxide which is poison. Do not make the engine run all the time in poor ventilated place. Open the door and window to keep good ventilation.

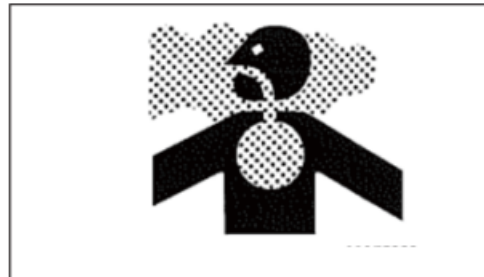

2.4 Before operatio

2.4.1 Starting check

Carry out starting check every day in order to ensure truck safe operation. Refer to “check and maintenance” for the detailed check item.

2.4.2 Check and adjust before starting

- Check the following item before starting
 - Check the lever of cooling liquid, fuel and engine oil. Check if air cleaner is blocked.
 - Adjust seat (seat position, back angle), steering wheel and back mirror. Make sure all lock devices are locked.

- Note when starting engine
 - Before starting, check if the parking brake is applied and operation levers (forward/backward and high/low speed lever) are in neutral position;
 - Before starting, sound the horn to warn around;When starting, check if it is safe around and sit on driver’s seat;
Never try to make the engine starting circuit short circuit on purpose to start the engine, or serious injury or fire may be caused. Do not start the engine through pushing the truck;

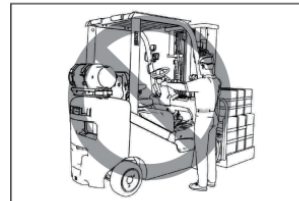

- Use gas or soap to check if LPG pipelines leak. It is prohibited to check with flame. If there is leakage, turn off all valves, keep the truck away from the open flame and contact your EKKO dealer.

2.4.3 Starting check

- Check the working condition of the meter especially the alarm light;
- Make sure the operator presence sensing system work well;
- If there is any abnormal such as noise, vibration, heating, smell, improper adjusting of meter, engine oil or fuel leakage, be sure to remove the faults before operation.

2.5 Travelling

2.5.1 Preparation before travelling

- Wear safety belt
 - Wear safety belt before operation;
 - Check if the safety belt is well;
 - Injury may occur if safety belt is improper fixed.

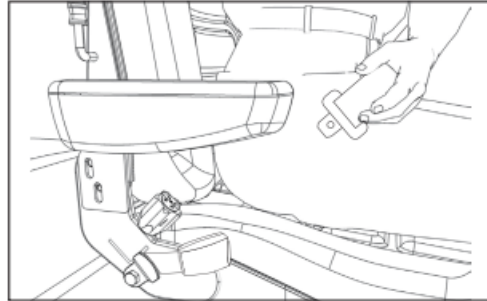

- Proper seat posture
 - If you operate the truck with improper seat posture or away from the seat, accident may occur.



- Standard operation posture
 - Do not put your hand and foot outside the overhead guard;
 - Keep your body under the overhead guard all the time.

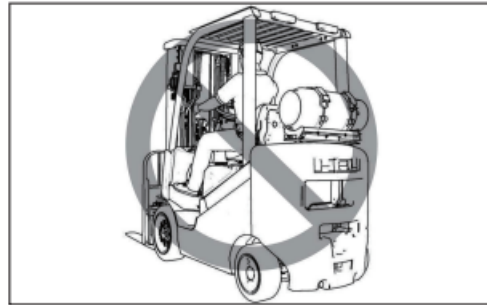

- Take care of the safety around before travelling;
 - Before travelling, check if there is any barrier around such as pedestrian, other vehicles or goods.
 - Lift the truck 15-20cm above and tilt back the mast;
 - Sound the horn if possible.

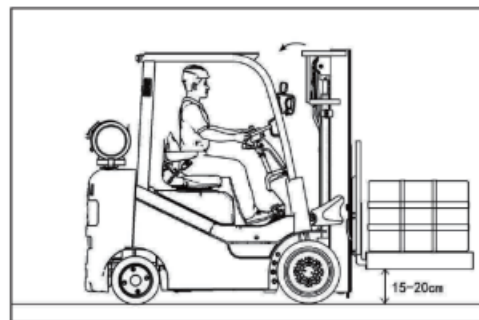

2.5.2 Notes when travelling

- Avoid sudden start, stop and direction change;
- Stop truck (hydraulic-powered truck) before direction change.

- Keep safety in mind during travelling
 - Avoid sudden start, brake and sharp turning;
 - Keep the travelling road with good visibility;
 - Slow down and keep a safe distance with the passing truck when passing truck;
 - Comply with the regulated limit speed and keep a safe distance with the other truck;
 - Pay attention to the area around the truck especially the travelling direction or when steering;
 - Never try to overtake other trucks in narrow road or area with poor sight such as crossroad;
 - Stop to ensure the safety around and sound the horn if necessary when turning at crossroad or travelling into narrow road;
 - Even the horn is sounded, pay attention to the moving of people around;
 - Do not let people enter the working area;
 - Give way to the loaded truck on ramp or in narrow area.

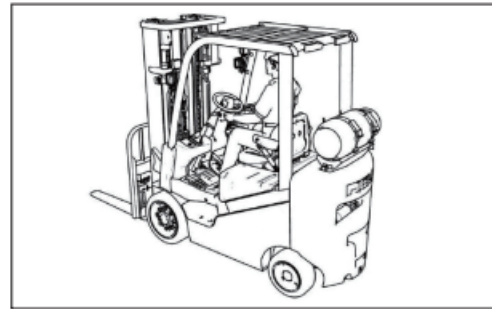

- Do not ride any people on the truck.
 - Do not ride any people on the truck at any case;
 - Do not ride people on the truck as a counter weight.

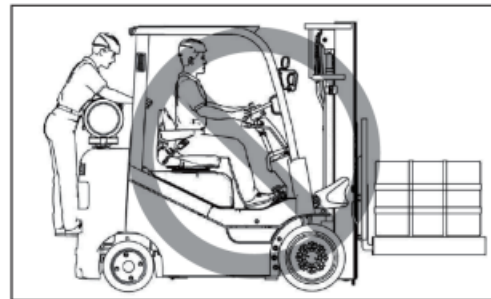

- Do not shut off the engine during travelling;
 - If starting key is turned to off position during travelling, the operation force on the powered steering will be increased and what is more accidents will be caused.

- Do not keep your foot on the inching pedal
 - Keep foot away from the inching pedal during normal travelling or the untimely worn out of the clutch and overheat of transmission unit;
 - Brake unit will be ineffective if the pedal is pressed to haft engaged with the clutch.

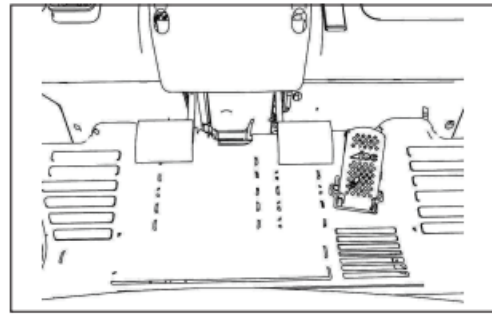

- Take care to control the reversing direction when travelling backward.
 - When travelling backward, check the back area visually. Do not depend on the backview mirror which is just an auxiliary device only completely when travelling backward.
 - Take care if there is anybody backward even the horn is sounded.

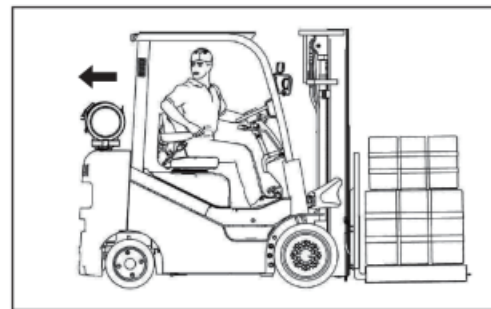

- Assign a towerman or travel backward when carrying a load with huge size.
 - Assign a towerman or travel backward if the front view is cut off in order to ensure the safety around;

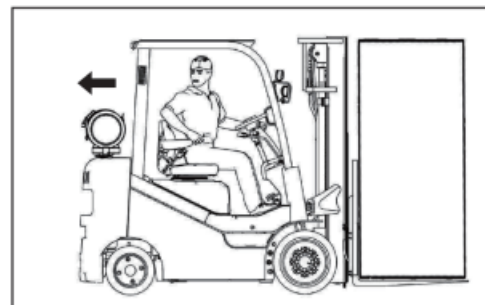

- Take care of the backview for the truck with LPG container.
 - Keep in mind that the truck with LPG container has poor backview which has a danger of collision of people around or goods. So make sure to check the back view, please look through the rear view mirror.:
- Contact with EKKO agent or dealer for detail with alarming devices such as a backward flasher, backward sensor, back view mirror and so on are needed.

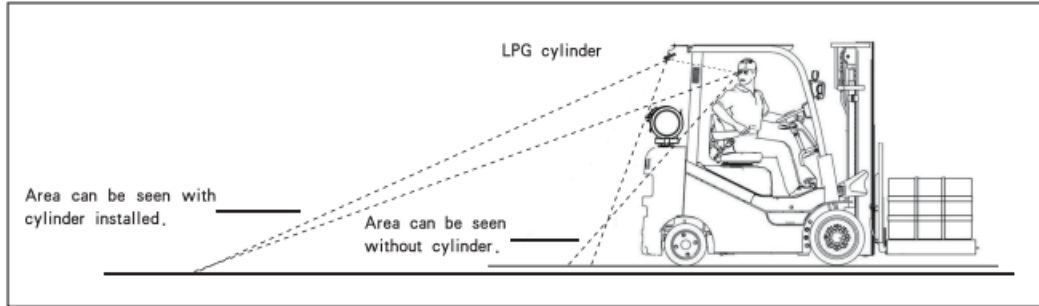

- Avoid travel with goods lifted.
 - The center of gravity will be lifted if there is loading device or lifted load. So there is a risk of tipping over. Do not travel with goods lifted. (lift the goods 15~20cm above and tilt back mast.)

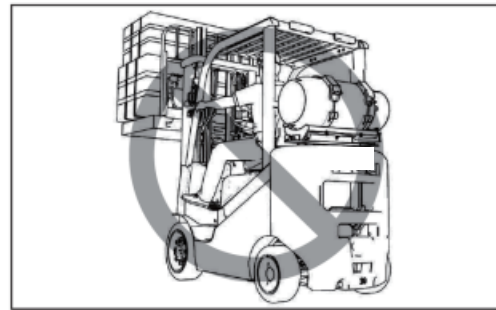

- Do not jump off the truck when the truck is tipping over.
 - Wear safety belt in case of truck tipping over;
 - Read the OPERATION AND MAINTENANCE MANUAL carefully and operate, check and maintain properly in order to avoid accident such as truck tipping over;
 - Do not jump off the truck if the truck tips over or serious injury may caused by truck ;
 - Body incline opposite the truck tipping over direction;
 - Grasp the steering wheel tightly;
 - Support your body with two feet.
- Practice the actions below and ensure you know how to do in case of emergency.

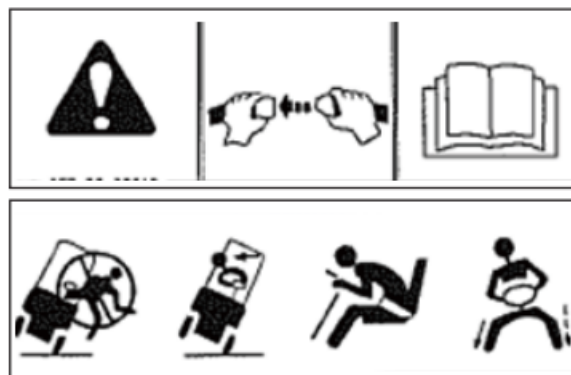

- Beware of the rear part rotation;
 - The steering wheel of the truck is its rear wheel which is different from the other kind of truck;
 - Keep a safe distance with the wall because the counter weight will rotate outside when steering.

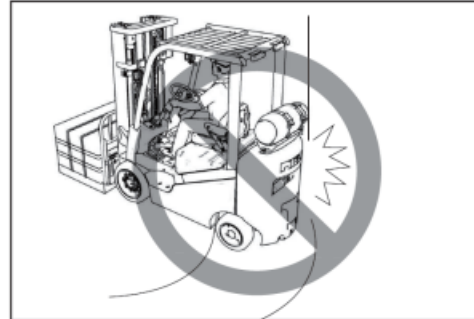

- Pay attention to the max. height and width of the truck
 - Make sure there is enough height and width when truck passing;
 - Keep a safe distance with mast, harness and pipeline;
 - Take care of the height of the mast and backrest when fork is lifted high.

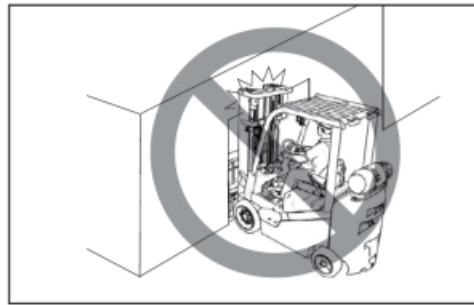

- Do not travel on uneven or slipping road.
 - Do not travel on uneven or soft road or serious accident will occur if steering is out of control or tire is sunk into mud;
 - Avoid travel slipping road with water or oil, or you will lose control of braking and steering.

- Pay attention to the load weight limit.
 - Never overloaded when travelling on road with weight limit.

- Do not travel over the barriers directly.
 - Avoid sundries, road teeth, rail, open trench and other barriers and do not travel over them. The compact force will cause body harm such as backpain.

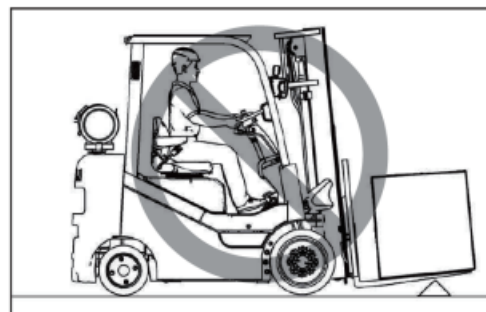

- Avoid travel on road shoulder.
- Do not travel close to the road shoulder which may sink.
- Keep a safe distance from the road shoulder or platform in preventing of truck falling.

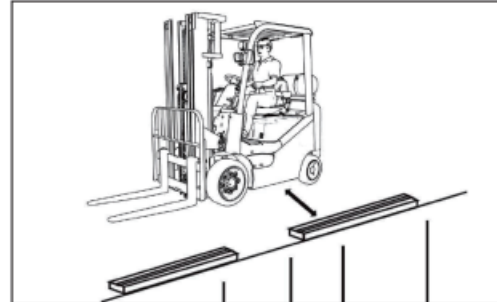

- Notes when travelling on a slope
- Do not make a sharp turn on the slope and take care of the distance from other truck, and departure angle avoiding danger;
- Before travel on a slope, stop the truck and adjust the distance between the fork and ground to keep the bottom of fork and pallet away from the ground, so as to avoid the fork top inserting to ground.

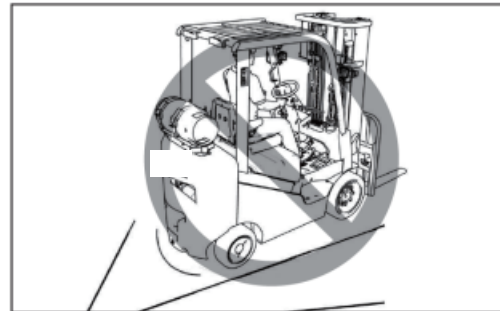

■ Safe travel on a slope

Loaded: travel forward when driving uphill; travel backward when driving downhill;

Unloaded: travel backward when driving uphill; travel forward when driving downhill;

- Travel downhill slowly with engine brake;
- It is prohibited to move your hip away from the seat when travel up or down the slope if the hydraulic-powered truck is assembled with OPS device or the power will be cut and accident will occur.

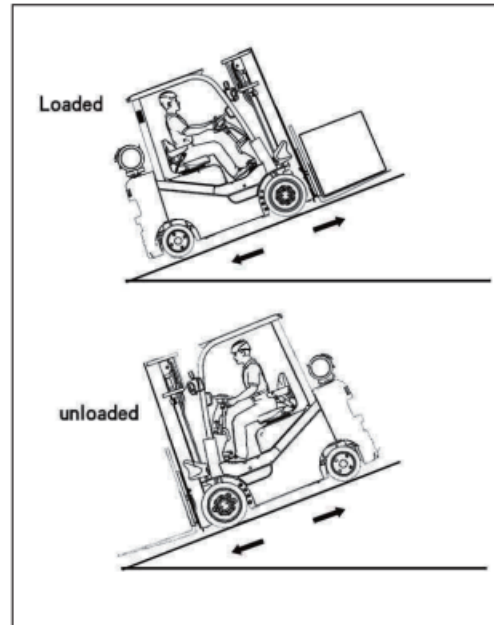

■ Notes when travel into railway lorry or container

• Check the brake and block applying to the lorry, trailer and container and make sure they are well stopped;

• Do not move the vehicles before the load carrying operation is finished;

• Make sure the board connecting to the vehicles can hold the travelling of forklift truck;

• Board should be connected firmly between lorry and trailer;

• Do not travel near the border of the platform or dock or the truck may fall down.

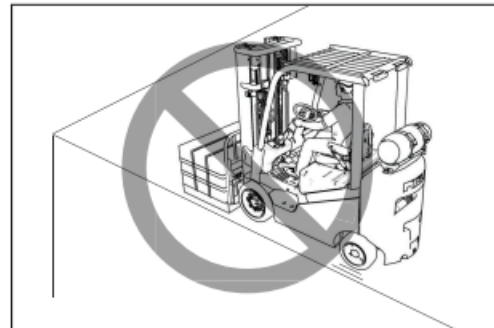

2.5.3 Notes on truck stopping and parking

■ Stop and park the truck according to proper procedures.

- Park the truck on solid and flat ground;
- Apply parking brake avoiding truck moving;
- Place the gear shifting levers on neutral.
- Tilt the mast and lower the fork to the ground;
- Turn the starting switch to the OFF position;
- Remove the starting switch key.



■ Park the truck at a safe place.

- Place the truck on solid and flat ground;
- Do not parking at the emergency exist or around safety devices; park at the place that does not disturb any passersby or other trucks;
- Do not park the truck on slope. If it has to, wedge the wheels.

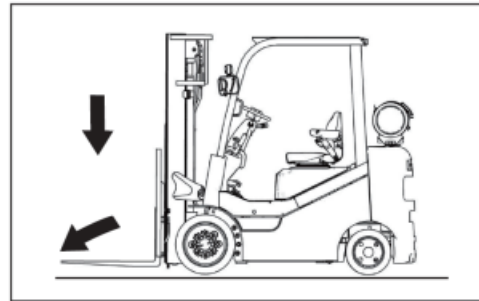

2.5.4 Notes on towing

- Proper using of traction pin
 - Traction pin is designed for the towing when it is sunk into channel or mud;
 - Do not use it for towing or lifting;
 - Use the traction pin as a fasten point when carrying by lorry.

- Do not tow damaged truck.
 - If there is any fault on the brake or steering system, do not tow with the other truck. Damaged truck may have accident during travelling.

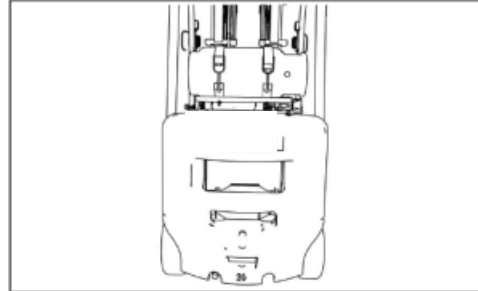

2.6 Load carrying operation

- When carrying loads, people and trucks without permit should leave the working area except for the towman.
 - Let the unauthorized persons and trucks be away from the working area except towman when loading and unloading to avoid accidents.
 - Assign a towman if necessary to ensure sight and other safety reasons;
 - Do according to the towman if towman works together.

- Do not stay under the lifted fork.
 - Lifted fork may fall down accidentally which may damage people under the fork. So stay away from the lifted fork.

- It is prohibited to work on fork.
 - Do not place load manually directly onto the fork;
 - Do not unload the load manually directly from the fork;
 - Do not step on the fork to load or unload goods because goods may slid from the fork;
 - Do not support the goods with hand because the sudden moving may cause load falling onto people.



- Take care not to be caught by mast.
 - Do not put hand, feet or other parts of your body into mast;
 - There is a danger of being caught by moving parts and serious injury.

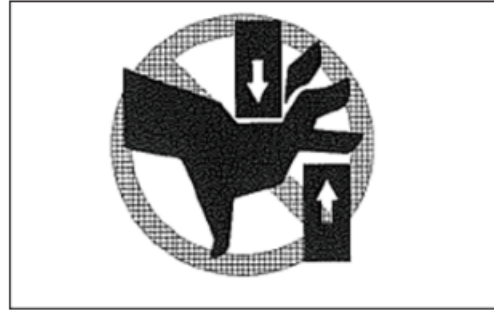

- Do not stand between the mast and driver's cab because serious injury or death may be caused by extruding.
- Operate the mast and fork from the driver's cab.

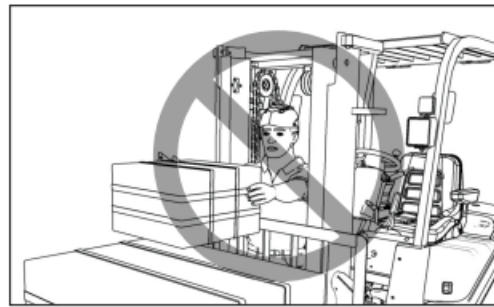

- Do not climb the mast or backrest.
 - There is danger of being caught by moving parts or falling if you climb onto the mast or backrest.

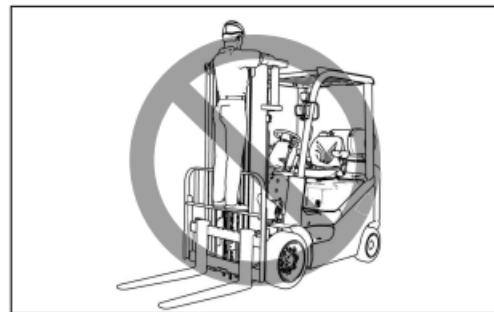

- Use the pallet with enough strength.
 - Use pallets and sliding plates with strong structure. Do not use damaged one.
 - Before travelling, check if the goods are placed on the pallet firmly and safety.

- Take care when carrying long and wide goods;
 - Take care when carrying long and wide goods. Lift the goods slowly so as not to collide anything around;
 - Keep the goods as low as possible and keep balance when changing direction.

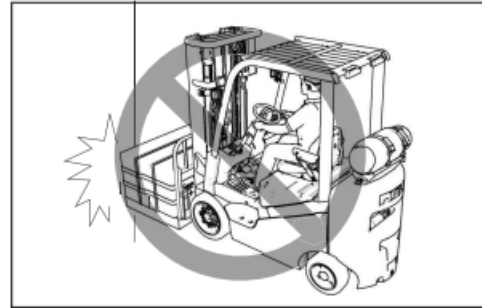

- Pay attention to the mast height
 - The mast height will increase with the lifting of fork. Take care when carry out such operation;
 - Take care not to touch electric wire, pipeline, water sprinkler, cross beam and so on. If there is any touch, goods on fork may fall.

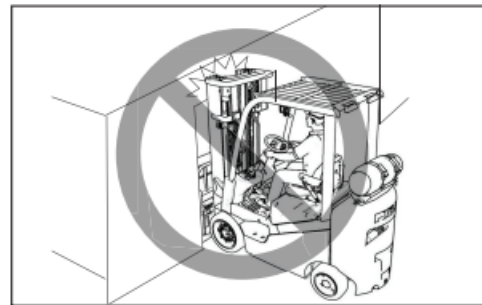

- No over loading.
 - The rear wheel will be away from the ground if the truck is over loaded and thus the truck will be out of balance. Do not exceed the max. capacity listed in the chart.

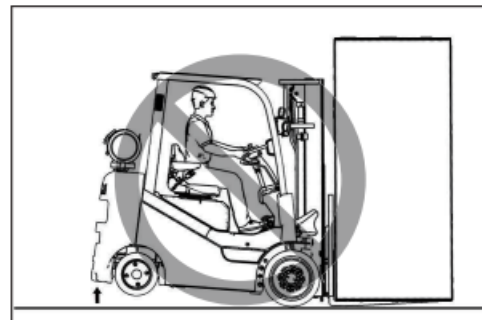

- Do not tilt the mast forward if there is load on the fork.
 - Do not tilt the mast forward when the load is lifted, or the good may fall down and truck may tip over;
 - Do not travel with the mast tilt forward.

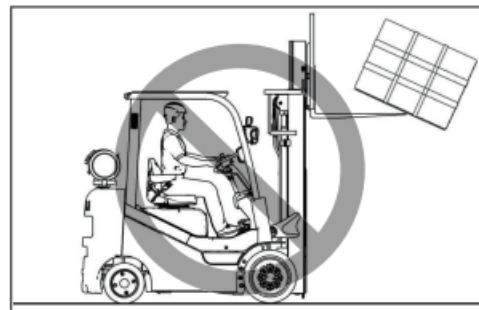

- Do not carry goods with insecurity measure.
 - Make sure the goods' center of gravity is in the same line with the truck's center of gravity. Do not carry unbalanced goods;
 - Fix the goods avoiding falling or collapse. Do not carry unstable goods;
 - Keep the goods in touch with the backrest.

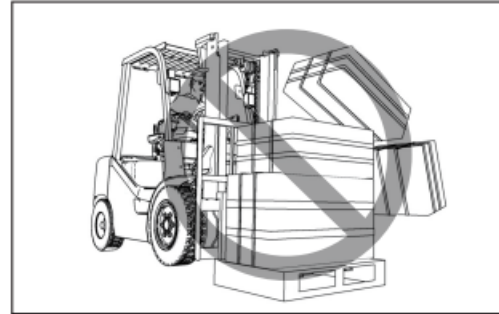

- Do not load and unload on a slope.
 - The truck will be out of balance and tip over when loading and unloading on the slope.

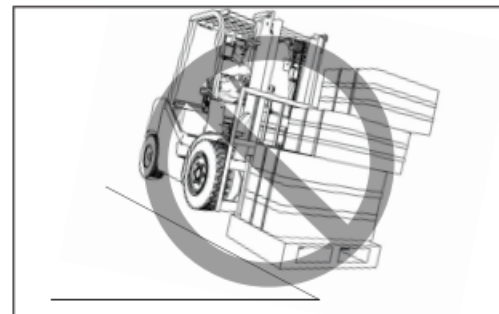

- Do not lower the loaded fork sharply.
 - Do not operate fork carelessly or stop it suddenly. Sudden lowering may cause goods to sink or fall down and thus the truck will be out of balance and tip over.

- Do not carry goods higher than the back rest.
 - If the goods are higher than the backrest, there is a danger of goods falling onto driver. So never carry goods higher than the back rest.

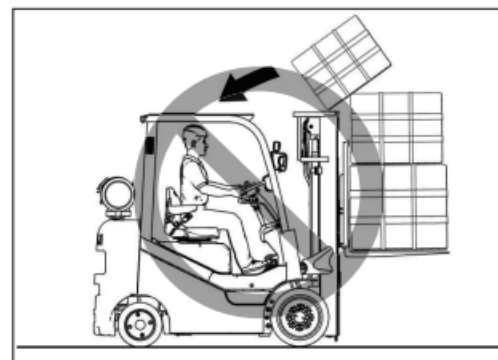

- Do not push goods by the tip of fork.
 - Do not push goods by the tip of fork or the good may break away from the fork tip and be damaged. The reaction may cause the truck and goods to move accidentally and is dangerous.

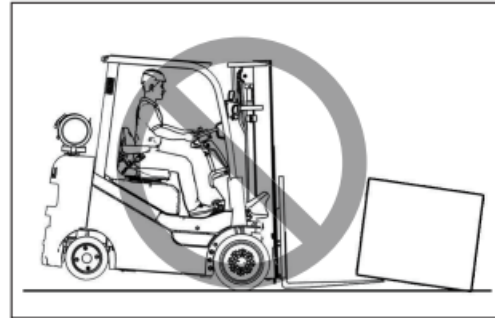

- Do not push or pull goods by fork.
 - There is a danger of goods damage or falling down.

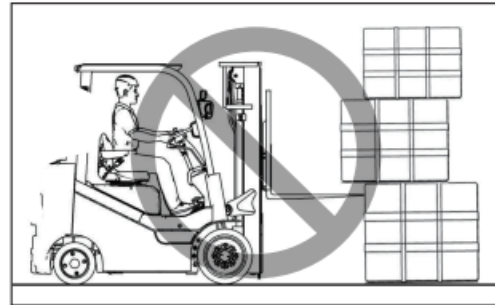

- Do not use the truck in other applications.
 - Do not use the truck in other applications except carrying goods with forks and other attachments;
 - Do not open or close the door of the wagon or warehouse;
 - Do not push or pull other vehicles;
 - Do not lift goods with rope. The rope hanged on the fork may slip, break away from the fork or be damaged. And meanwhile the truck may be out of balance because of the rotating of goods.

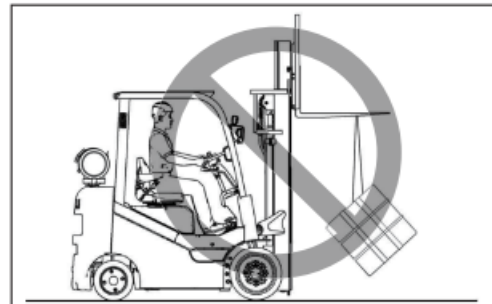

2.7 Check and maintenance notes

2.7.1 Be sure to carry out the starting check

- Only easy check and maintenance are included in the operation and maintenance manual. For the check and maintenance that should be carried out by trained and qualified people, please contact your EKKO dealer/agent.

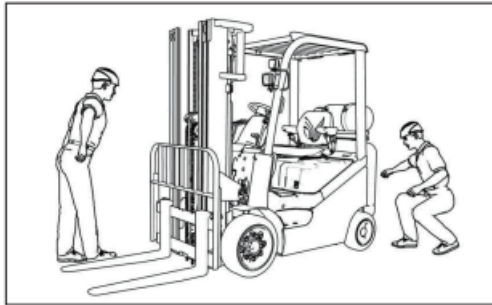

- Do not start the truck before starting check;
- If there is any abnormal, report to the manager at once and do not operate the truck until it is repaired;
- Serious accident and adverse effect may be caused by improper check, maintenance and repair. For safety reason, contact your EKKO dealer/agent for certain check, maintenance and repair.

2.7.2 Place a warning sign around during check and maintenance

- Place a warning mark on the steering wheel or operation lever when checking and maintaining. If necessary, place the mark near the truck.
- During check and maintenance, Nobody is allowed to start engine or operate levers except the checking and maintenance person, or serious injury may be caused.
- Assign a responsible person and do according his guide when check or maintenance are carried by more than one person.

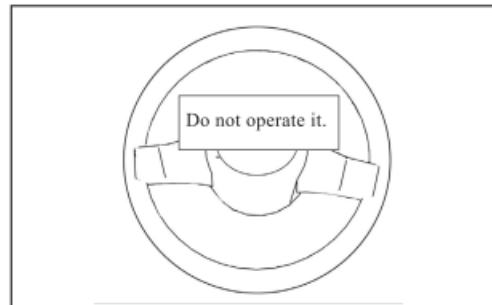

2.7.3 Keep the working area clean and tidy

- Keep the working area clean and tidy. Remove the barriers, grease and oil.
 - The truck should work on flat ground with enough space.
 - Ensure good ventilation if the truck works inside a building.
-

2.7.4 Notes before check and maintenance

- Allocate a fire extinguisher and know its position and using method;
 - Keep the people with long or fluffy hair or loose clothes away from the mast during operation;
 - Wear proper working suits and safety equipments (safety cap, safety shoes, glasses and gloves);
 - Lower the fork to the ground and apply parking brake. Place all levers on neutral position and turn the starting key to OFF position and shut off engine;
 - Wedge up wheels.
 - Take preventive measures to prevent check and maintenance devices or equipments from causing spark, flame or other fire danger.
-

2.7.5 Let the unauthorized people be away

- Unauthorized people should not stay near the truck during maintenance.

2.7.6 Proper using of the tools and devices

- Use the proper tool correctly. Do not use damaged or deformed tool and tool using for other purpose or serious accident will be caused.



2.7.7 Notes when working under the working devices

- Support fork and mast avoiding falling when working under the fork or serious accident will be caused.

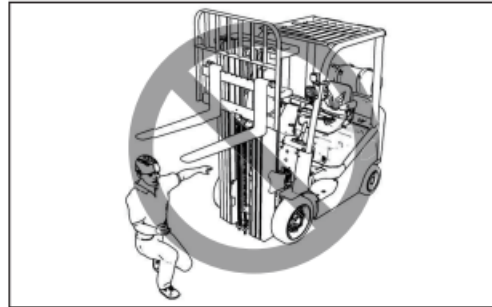

2.7.8 Beware not to be caught by mast or falling

- Do not put your hand, foot or other part into mast or there is a danger of being caught.
- Do not stand between the mast and overhead guard or you may be extruded and serious injury or death may be caused.



- Operate the mast and fork inside of the overhead guard.
- Do not climb onto the mast, backrest or splash guard, or you may slip into or be caught by moving parts. Check and maintain the top area with ladder.

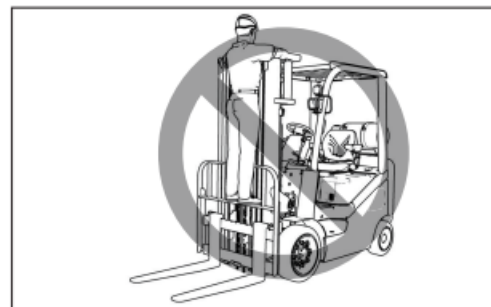

2.7.9 Beware of the boiling cooling liquid

- Do not remove the radiator's cap as soon as the truck is stopped because the cooling liquid has high temperature and pressure, or you may be scalded.
- When removing the radiator's cap, rotate it slowly until the cooling liquid is cool to release inside pressure.



2.7.10 Take care of the high pressure oil

Remember: the hydraulic system is under the pressure condition all the time. Before check or change hoses or pipes, check if the hydraulic system has pressure or serious accident may occur. Please abide the following description:

- Do not touch the hoses or pipes with hand directly when checking if there is leakage. The hoses and pipes may be pressurized.



- If your skin or eye is harmed by high pressure oil, wash with clean water at once and go to see a doctor.

2.7.11 Beware of the rotating belt and fan

- Keep your hand away from the rotating belt and fan.

- Shut off the engine before open the engine hood which is only can be done by authorized person.



2.7.12 Notes when repairing electric system

- Disconnect the cable of the positive terminal in order to disconnect the power when repairing electric system.

2.7.13 Notes when cleaning with compressed air

- Dust is harmful to health when washing with compressed air.
- Wear protection devices such as glasses, gloves and mask.

2.7.14 Notes when dealing with battery

The battery will produce hydrogen and oxygen during charging which may explode and electrolyte contains dilute sulphuric acid. Personal injury, explosion or fire may be caused if the battery is improper dealt. Please follow the rules below:

- Do not use the battery or charge the battery if the electrolyte is lower than the min. level. Or explosion may be caused.
- Wear safety glasses and rubber glove when dealing with the battery.
- Do not smoke or make the open flame be close the battery.

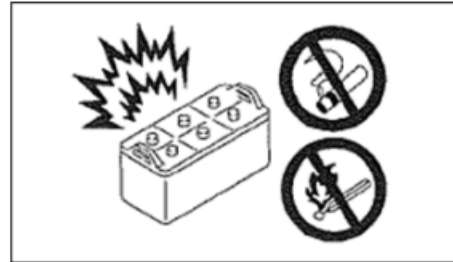

- Wash with plenty of tap water at once if any part of your body contact with the electrolyte.

- If electrolyte gets into eye, wash with plenty of tap water at once and see a doctor in time.
- Turn the starting switch to the OFF position when dealing with the battery.

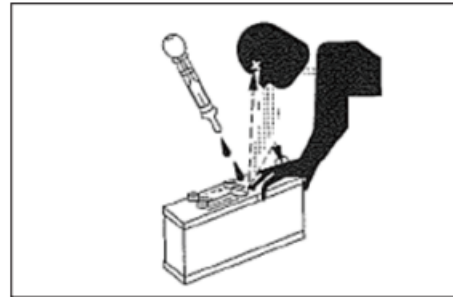

2.7.15 Follow the rules strictly so as to avoid spark

2.7.15 Follow the rules strictly so as to avoid spark

- Do not place tools or other metal object on battery for they may contact with the battery positive and negative terminals.
- Disconnect the negative terminal cable first when disconnecting the batter cable. On the opposite side, connect the positive terminal cable first when connecting.

2.7.16 Note when installing or removing the battery

- When installing or removing the battery, take care not to damage the battery or electrolyte may leak.



2.7.17 Note when dealing with the tyres

■ Maintain the tyres once a month. Check if there is abrasion loss, scratch, deformation, split, delaminating, aging and so on. Clear foreign matters in the tyre or pattern in order to avoid puncturing of the tyre. Check if the tyre and rim are properly installed.

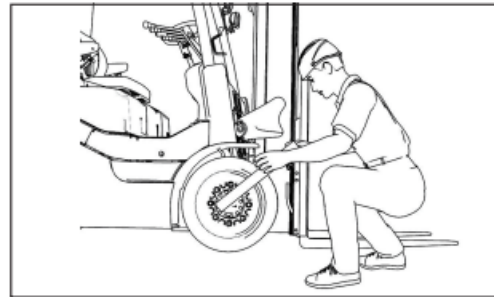

- Rim will not fit the tire well if it's improperly assembled or there is any fault with the tire or there is any fault with the tire or rim. Rim should connect well with the tire in place. If necessary, contact your EKKO dealer.

2.7.18 Note when dealing with the waste

Take care to deal with the waste in order to protect the environment.

- Keep the waste liquor such as engine oil and electrolyte in a container like jar. (Do not keep the electrolyte in a metal container and be sure to keep it in a plastic container). Never drain the waste liquor into earth, river, drainage ditch, sea or lake.
- When dealing with injurant such as engine oil, fuel, cooling liquid, solution and battery, stick to the relative law.



2.7.19 Notes after check and repair

- Wipe off the oil and lubricating grease at once. If the truck is dirty, fault such as crack is hard to be found.
- Check if there is any abnormal after the truck is repaired.

2.7.20 Regular check on the key part

- Lubricate, check and maintain the truck especially the key parts regularly in order to ensure the truck safety and long service life. Change then regularly.
 - Parts will go bad, worn or fatigued if they overrun their service time and serious injury and damage will be caused. Parts service life is hard to be distinguished by visual check.
 - Replace the key parts regularly.
 - If there is any abnormal, change the key part even it is undue.
-
- Note:
 - Check and change of the key parts and lubrication grease adding should be carried out an EKKO dealer or agent.

2.8 Transportation and hanging up

2.8.1 Notes when hanging up truck

- Do not hang up the truck at the overhead guard.

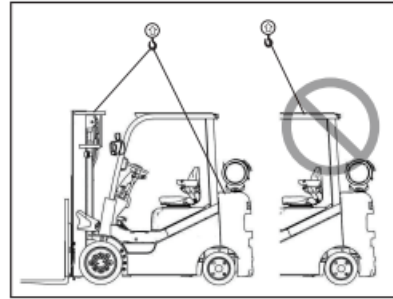

- Before hanging up, check if the bolts of the mast and counter weight are tighten to the regulated torque.
 - Refer to the “maintenance data” for torque value of the counter weight fixing bolts.
 - Refer to the “maintenance data” for torque value of the lower mast fixing bolts.
- When hanging up truck, hook the hole on the bottom of the external mast and the counter weight and rear axial.
- Do not stay under the lifted truck.
- Use undamaged slings and steel rope with enough strength.
- Please contact your EKKO dealer or agent for special sling equipment if the truck has to be hung up frequently.

2.8.2 Notes when loading or unloading the truck

There is a danger of tipping over and falling when loading or unloading the forklift truck onto or from the trailer. So follow the rules below:

- Park the trailer on a flat road. Apply parking brake and wedge the wheels.
- Use connection board with proper length, width and strength.

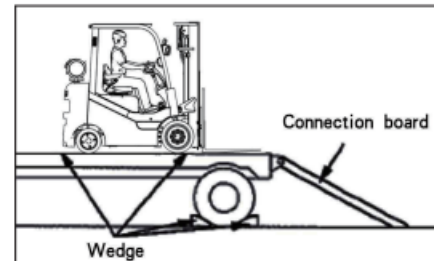

- Operate the truck with proper posture.
- If the truck which is hydraulic powered type and is assembled with OPS is operated with such posture (the seat does not bear your whole weight, for example stand or lean against forward, backward or side when operating), the power will be cut for 3 seconds and in that case, the truck will slide down even acceleration pedal is pressed or the truck is going uphill. If necessary, assign a towerman, so that the driver is not necessary to stand or lean forward or side to observe around.
- Place the board to form a gentle slope when using it. Align the center of the forklift truck and trailer's and lock firmly avoiding displacement.
- Do not change the direction when travelling on a board. If necessary, place the board again according to the needed direction and travel again.

2.9 Truck structure and stability

2.9.1 Longitudinal stability

- Load is balanced with the weight on the rear wheel with the front wheel as the supporting point so as to avoid truck tilting forward.
- If the truck is overloaded, the rear wheel will lift away from the surface. It is dangerous and serious accident will occur such as tipping over.

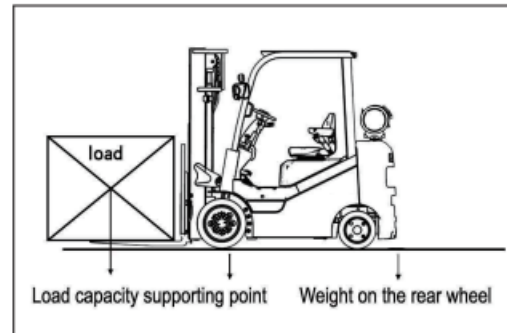

2.9.2 Load center of gravity

- Shapes of goods are different.
- Ensure load center of gravity is very important for truck stability.

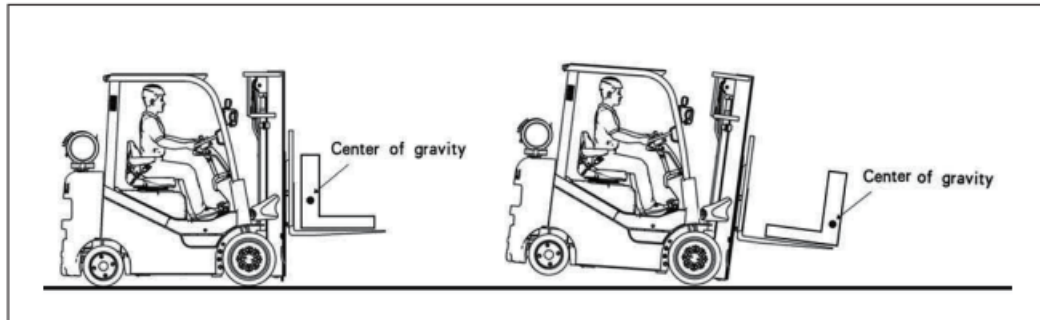

2.9.3 Combined center of gravity and loaded truck stability

Combined center of gravity

The loaded truck's center of gravity is moved to the combined center of gravity of the truck and goods. The combined center of gravity is lifted as the goods are lifted.

Combined center of gravity and stability

The stability in both longitudinal and horizontal direction will be poorer and poorer with the center of gravity being higher and higher. Besides, swinging and vibration during travelling and loading affect the truck stability.

- Truck stability will change because of the following factors:
 - Load size, weight and shape (center of gravity)
 - Lifting height
 - Mast tilting angle
 - Tyre inflation pressure
 - Acceleration and deceleration during travelling and lading and unloading and steering speed
 - Road condition and gradient
 - Attachments type

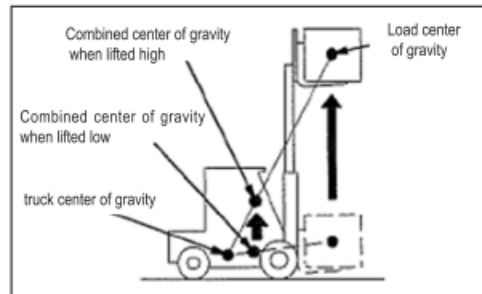

Do not travel when the fork (goods) is lifting; do not steer sharply; do not brake suddenly; do not lift or tilt fork suddenly; or there is a danger of accident such as tipping over.

2.9.4 Actual loading capacity

- Load center refers to the horizontal distance from the center of gravity on the fork to the backrest. Actual loading capacity is the max. loading capacity on certain load center.
- Capacity chart on the name plate can be seen from the driver's seat. It shows the relationship between the actual loading capacity and the load center.
- When load center moves to the fork tips, lower the load capacity to maintain the balance in actual operation.

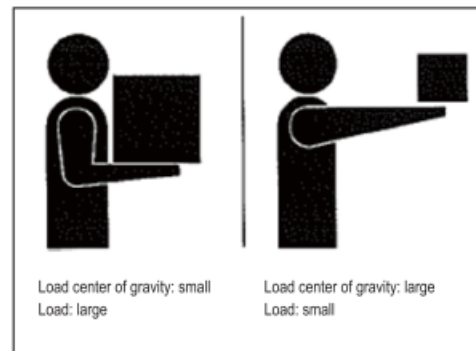

2.9.5 Instruction on the capacity chart

- Instruction on the capacity chart
 - The actual loading capacity and max. load capacity are shown in the capacity chart. Before loading, make sure the load center and load capacity are in the allowed range.
 - Fix the load if it has complex shape in order to make the heaviest part lay against backrest and the horizontal center stay on the center of the two forks.
 - The rear wheel will be away from the ground if the truck is over loaded and thus the truck will be out of balance. Ensure the load capacity stays in the allowed range.
- Series number plates on the truck shows the work permit range. Contact your EKKO dealer or agent to change the damaged or unclear plate.

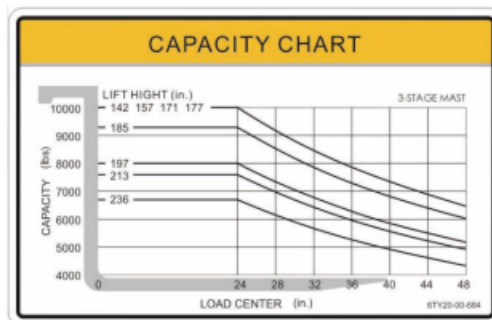
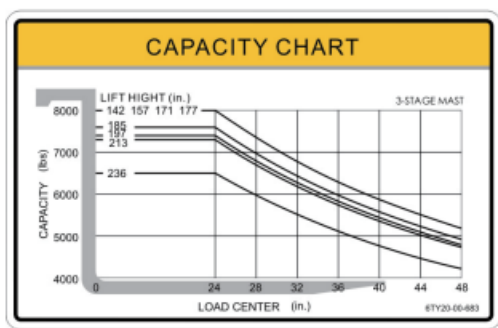

If the load capacity exceeds the requirements in the capacity chart, the truck’s rear wheel may be lifted away from the ground. In that case, steering may be out of control and the truck may tip over. If the truck is assembled with attachments such as side shifter, clamp, rotator and so on, the allowed capacity will be lowered than the capacity of the truck without attachments. The reasons are below:

- a) The capacity is attachment weight lower than the one of the truck without attachment.
 - b) Long attachments make the center of gravity forward and thus the loading capacity will be reduced.
- According to the truck and attachment brochures, calculate the actual capacity through the loading capacity formula if attachment is assembled by yourself or contact with our company.

2.9.6 Instruction on safety devices choice

Safety devices are optional. Contact your EKKO dealer or agent for detail. Devices and equipment’s listed below may not work in certain conditions. Install the devices according to the instructions for safety reason.

- Working light
 - on top of the truck and at the rear side of the truck

- Travelling (forward/backward) or approaching alarm
 - rotating warning light and flash light

- Speed alarm
 - Speedometer and buzzer

- Fire extinguisher

2.10 Towing

■ Fault truck towing

Be care if there is any of the fault below when towing a truck:

- Fault of brake
- fault of steering
- fault of tyre
- fault of traction pin
- Move the truck on a abrupt slope

The truck is hard to control if the steering motor does not work. if there is no power, there is no powered steering. Do not tow the truck which has no power, or truck may be damaged or slip because of improper towing.

If towing on a abrupt slope, apply another brake power to stop the truck.

Never handle the fault truck with another forklift truck unless it has to be moved and it can not be towed. The handling truck must has the capacity equals to or larger than the weight of the fault truck. The towing truck's fork length must larger than the width of the whole fault truck. Keep the weight of the fault truck stay on the center of two forks. Take care not to damage the bottom of the truck.

■ Towing

Towing method:

- The towed truck must have operator.
- Tow the truck slowly.
- Lift the pallet and mast for towing.
- If a forklift truck is used to tow a fault truck, the truck's capacity must be no less than the fault one.

When towing, load the truck with goods that have half of the rated capacity's weight to increase the towing force and keep the goods as low as possible.

- Connect the two truck's towing pin on counter weight with a steel traction chain.

OPERATION



WARNING

Please read the manual and safety notes carefully.
When operating the truck, please follow the safety notes or serious injuries may be caused.

3.1 General view

3.1.1 Truck general view

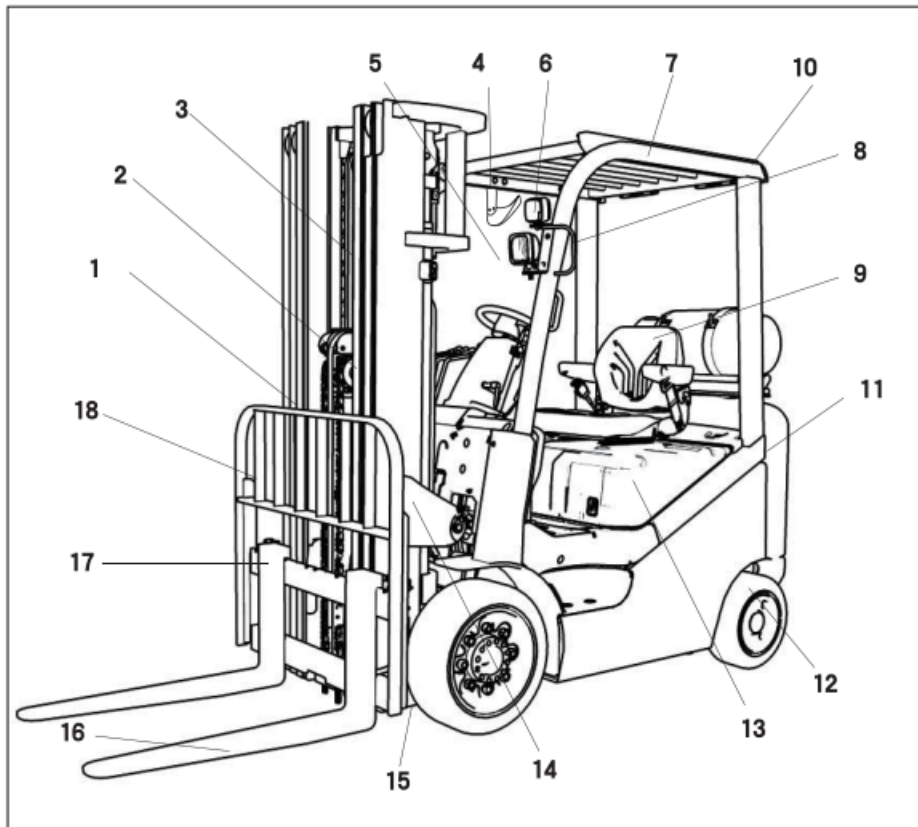

- | | |
|---|--------------------|
| 1. mast | 11. counter weight |
| 2. Lifting chain | 12. Rear wheel |
| 3. Lifting cylinder | 13. Engine hood |
| 4. Rear view mirror | 14. tilt cylinder |
| 5. Front lamp | 15. Front wheel |
| 6. Steering light and stopping light | 16. Fork |
| 7. Overhead guard | 17. Fork bracket |
| 8. handle | 18. Backrest |
| 9. Seat | |
| 10. Rear combined light (steering light, backward light, braking light , width light) | |

3.1.2 Instrument and control devices

■ Cab

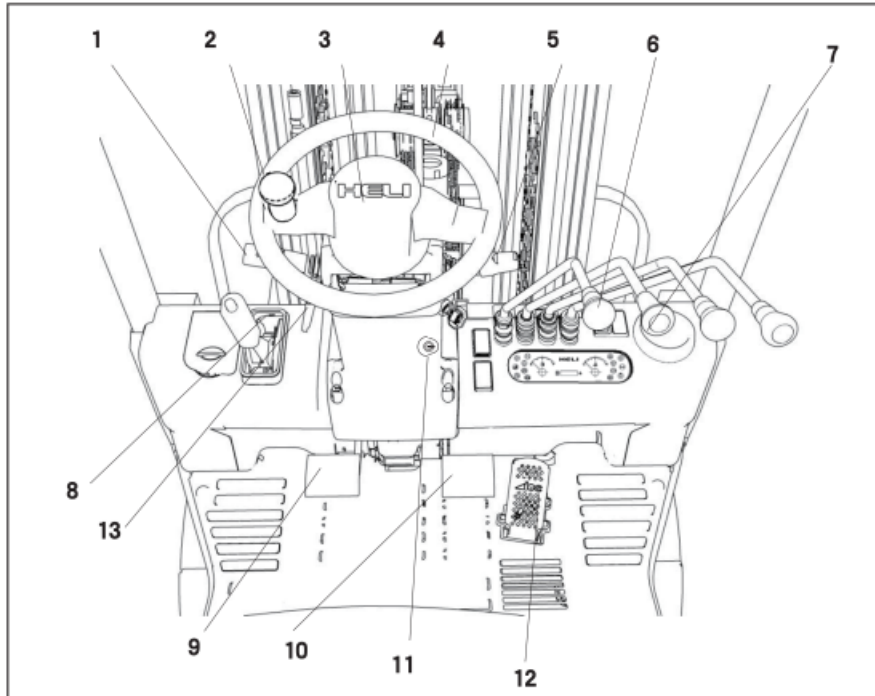

- | | |
|-------------------------------------|--|
| 1. forward/backward operation lever | 9. Inching pedal |
| 2. Steering wheel spherical handle | 10. Brake pedal |
| 3. Horn | 11. Starting motor switch |
| 4. Steering hand wheel | 12. Acceleration pedal |
| 5. Combined light switch | 13. Tilttable steering hand wheel lock lever |
| 6. Lifting lever | |
| 7. Tilting lever | |
| 8. Parking brake | |

3.2 Parts instruction

■ Devices necessary for the truck are described below.

It is very important to be familiar with the devices in order to operate the truck properly.

3.2.1 Meter

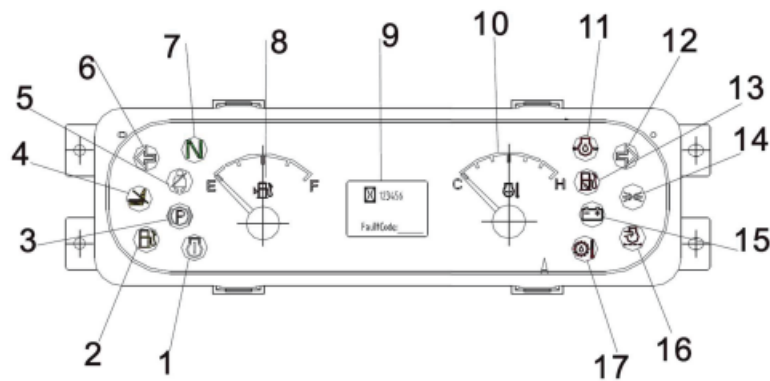

1. Engine fault signal
2. Low fuel alarm
3. Parking brake signal
4. OPS indicator
5. Safety belt indicator
6. Left turning indicator
7. Neutral indicator
8. Fuel gauge

9. Hour meter
10. Engine coolant temperature meter
11. Engine oil pressure alarm indicator
12. Right turning indicator
13. Low liquid level alarm indicator
14. Instrument lighting
15. No charging alarm indicator
16. Air cleaner block alarm indicator
17. Torque converter oil temperature alarm indicator

■ Methods of alarm indicators' bulbs checking

• Make sure the alarm indicators light on when the engine is not working and the starting switch is turned to ON position.

- Check if the bulbs are damaged if any of the indicators is off. It is abnormal when the alarming indicator is on during operation. Repair it and contact the HELI dealer or agent.

■ Fuel gauge

Oil quantity is shown on the fuel gauge. Check it on a flat ground. Check the oil quantity when the engine starting switch is on ON position.

Position E: it means that the oil level is low.

Position F: it means the oil tank is full.

Add fuel before it runs out.

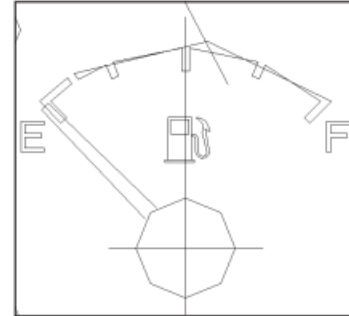

■ Neutral indicator

Neutral indicator means the forward/backward operation lever is on neutral position.

When the starting switch is on ON position, the neutral indicator will light on if the forward and backward operation lever is on neutral position. The indicator turns off when the lever is on forward or backward position.

Before starting the engine, turn the starting switch to the ON position and check if the neutral indicator is on.

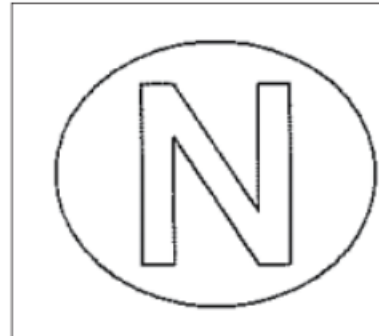

■ OPS indicator

When OPS is activated, the indicator turns on and the transmission box power is cut.

When you sit on the driver's seat with proper posture and place the forward/backward operation lever, the indicator turns off and the truck is ready for travelling.

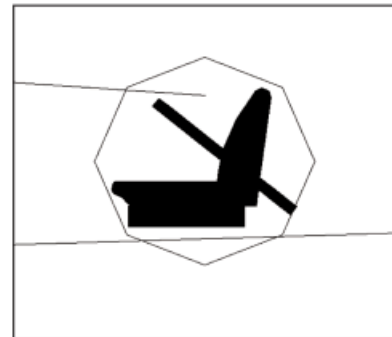

■ Engine oil pressure alarm indicator

It means the abnormal of the engine lubricating oil pressure.

The light will turn on when the starting switch is turned to ON position and it will turn off after the engine is started.

During operation, stop the engine and check the engine lubricating system and engine oil level when it turns on.

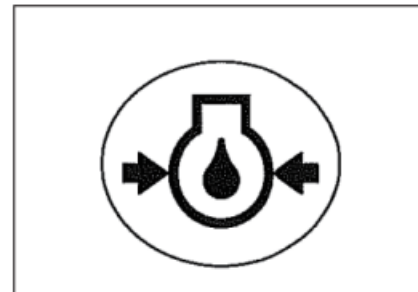

■ No charging alarm indicator

When the engine is working, the alarm indicator means the abnormal of the AC type generator's charging system.

When the starting switch is turned to ON position, the indicator will turn on and it will turn off after the engine is started.

During travelling, if the indicator turns on, check the electric system and if the V belt is loose.

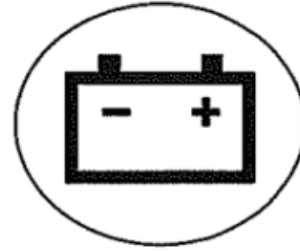

■ Working indicator

The hourglass signal on the left side of the hour meter means the hour meter is working.

The signal flickers when the engine is working.

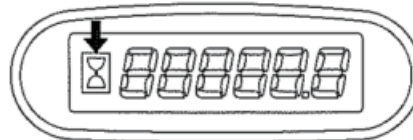

■ Hour meter

When the engine is started, the hour meter begins to work and accumulated working time is displayed. (when the hour meter is working, the operation indicator keeps flickering.

Affirm the checking interval and working hours referring to the hour meter.

If the engine works 6 minutes continually, 1 is carried over to the last digit (it means 0.1 hour.)

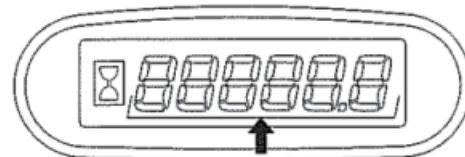

■ Engine coolant temperature meter

Engine coolant temperature is indicated by a pointer.

White range: normal

Red range: over heat

Important

Stop operating the truck at once and park it in a safe place if the pointer point to the red range and then carry out corresponding measures.

For engine overheating, refer to 4.7 Measures of engine overheating.

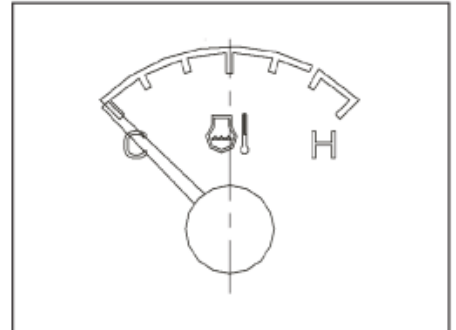

3.2.2 Imported LPG cylinder

Charging port: When charging, it is connected with charging equipment.

Charging valve: it is only open when charging. it should be closed at any other time.

80% liquid level hole: when charging, turn on the hole. When 80% liquid level hole is reached and there is white vaporific LPG gas belching out, then stop charging at once.

Releasing port: it is connected with truck LPG pipeline.

Releasing valve: Turn on or turn off the valve achieve its function.

Safety valve: when the pressure inside of the cylinder exceeds the regulated value, it will open automatically to release the pressure inside to a safe value and then close automatically.

3.2.3 Operating devices

■ Starting motor switch

The switch is used to start or shut off the engine.

(1) [0] position: on OFF position, you can insert or draw out the starting key.

(2) [I] position: on ON position, the electric circuit has electricity. For truck with diesel engine, preheating is started automatically.

(3) [II] position: On starting position, starter begins to work so as to start the engine. The key will be back to [I] position automatically when you loose the engine starting key after the engine is started.

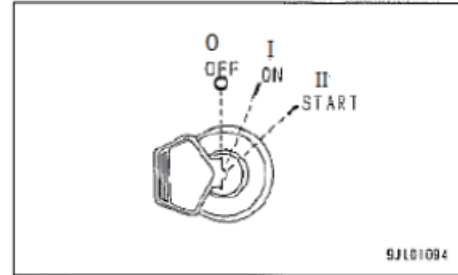

Important

Do not let the starting key stay on the [I](ON) position or battery electricity will be reduced and is hard to start the engine.

■ Horn

Press the button on the middle of the steering hand wheel and the horn will sound.

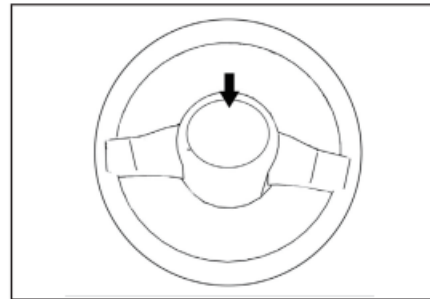

■ Forward / backward operating lever

The lever is used to change the truck travelling direction (forward/backward).

↑ : F(forward)

● : N(neutral)

↓ : R (reverse)

Engine will not be started if the lever is not on N (neutral) position.

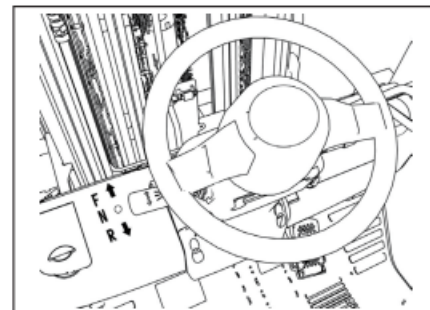

■ Combined light (lighting/steering signal switch)
The knob is fixed with lighting and steering signal switch.

■ Lighting switch
When the switch is turned according to the arrow mark, lights will turn on or off as shown below.

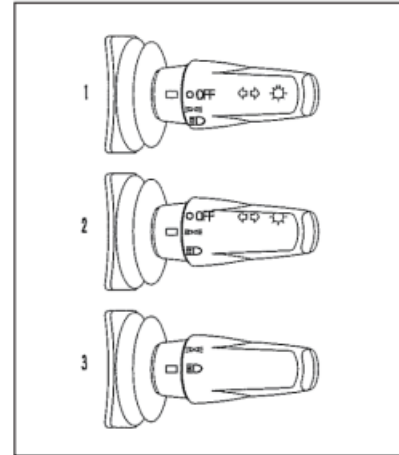

NO.	Front light	Meter light, side marker, front width light, rear width light and tail light
1	OFF	OFF
2	OFF	ON
3	ON	ON

■ Steering signal switch
Left turning (L): push the knob forward
Right turning (R): pull the knob backward
When turn the steering hand wheel backward, the knob will go back to neutral position.

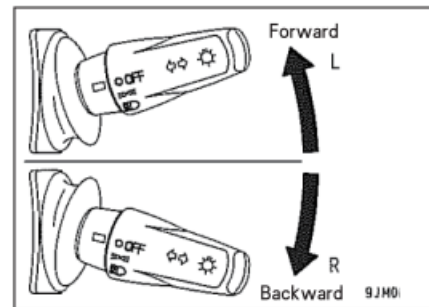

■ Parking brake handle

The handle is used to operate parking brake.
Pull the handle back completely (to lock position) and the parking brake is applied.
When releasing parking brake, pull the handle back and press down the button on top of the handle at the same time. Then press the button and push the handle forward at the same time to make the handle to be placed at the very leading position.

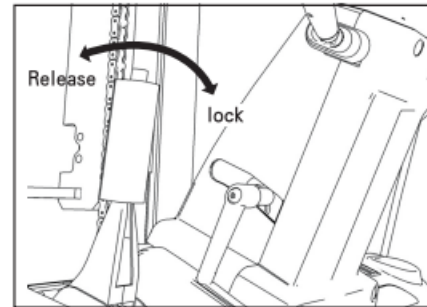

■ Acceleration pedal

The pedal is used to adjust travelling speed.
Engine rotation speed will increase according to the stepping distance.

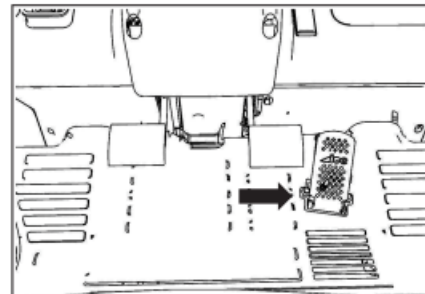

■ Brake pedal

The pedal is used to stop or slow down.

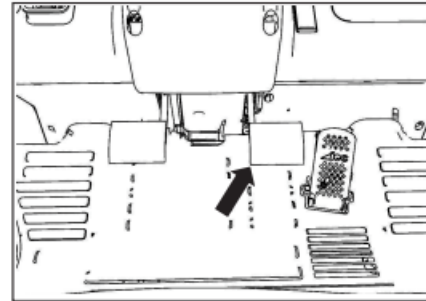

■ Inching pedal

When travelling with low speed (such as loads handling operation), the pedal is used to adjust the travelling speed.

Step on the pedal slightly to make the clutch half engaged and the truck will inching forward. Step the pedal more and the brake pedal together, the brake force is applied. Step on the pedal fully and the clutch will be separated and brake force will be applied.

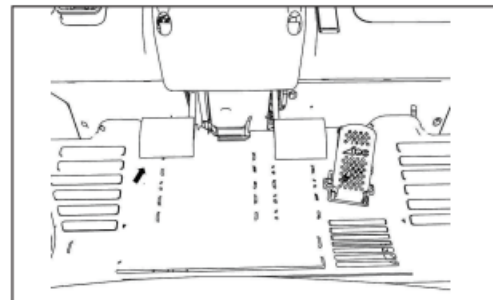

■ Lifting control lever

It is used to control the fork lifting and lowering.

Lifting: press the control lever downward;

Lowering: push the control valve upward.

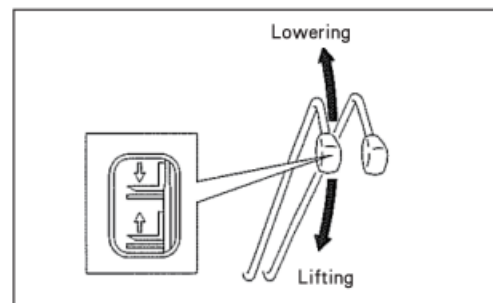

- Tilting control lever
It is used to tilt the mast forward or backward.
Tilt forward: Push the control valve upward;
Tilt backward: Press the control lever downward

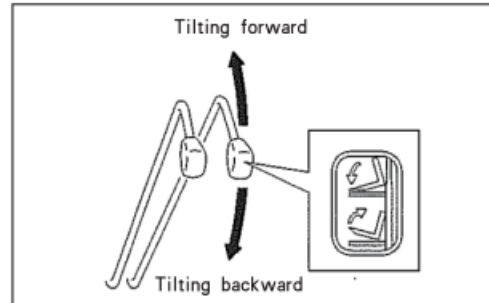

- Steering hand wheel
Steering hand wheel is used to change the left-right direction.

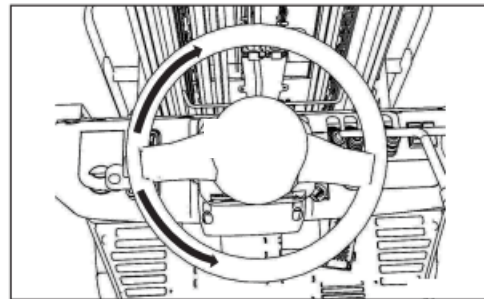

- Tiltable steering hand wheel lock lever
The lever is used to adjust the steering hand wheel tilting angle (upward/downward). Raise the lever, the steering hand wheel lock nut will lose and the steering hand wheel tilting angle can be adjusted. Push the lever down to lock the steering hand wheel after adjusting.

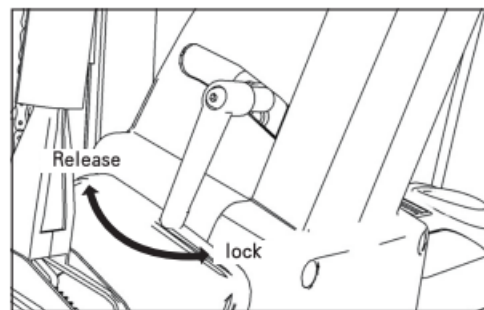

3.2.4 Assembly and disassembly of the attachments

Safety notes

 **WARNING**

Attachments and main parts are heavy and serious injury will be caused if they are carried improperly.

1. When working under the lifted attachments with goods, fix them avoiding lowering. Do not walk or stay under the impending goods. Use load support equipments such as steel rope and steel chain with good condition.
2. If work is done, fix the truck avoiding truck moving accidently.
3. When repairing or changing the hydraulic or electrical parts, observe truck related set value.
4. Any person is prohibited to stay in the dangerous place around the truck.

■ Fork

- Lower the fork bracket and until the fork contact with the ground and the lifting chain is under the tight condition.
- Lose the fork stopper and move the fork to the middle position. Put the lower hook to the cut and disassemble the fork.
- The steps of assembly are opposite from the disassembly. Apply grease to the fork hook and adjust the fork to proper width.

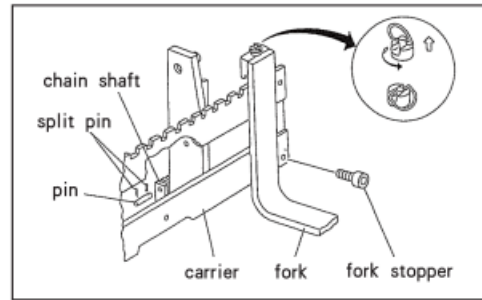

■ Fork bracket

- Lower the fork bracket until the fork contact with the ground.
- Disconnect the lifting chain and connect the end of the chain to the upper beam of the outer mast.
- Lift the inner mast with the lifting equipment until the bottom of the inner mast be away from the roller assembly on top of the carrier.
- Make sure that the chain does not kink when lifting.
- Reverse the truck and make it be away from the carrier.
- The steps of assembly are opposite from the disassembly. If there is no side shifting carrier, move the fork bracket to the limit several times and exhaust the air in the system.

■ Mast

Before disassemble the mast, disassemble the fork bracket and fork referring to the instruction before. Disassemble the driving wheel (if needed)

1. Suspend the lifting slings to the lifting eye on the upper cross beam and lift the mast. Remove the tilt cylinder from the mast pin roll.
2. Disconnect the hydraulic pipeline from the lifting cylinder and block all open mouth in preventing foreign matters entering.

CAUTION

The remaining oil will be exhausted out when disconnected.

3. Tilt the mast a little forward and disassemble the assembling bolts.

The steps of assembly are opposite from the disassembly. Take care of the following notes:

- 1) Replace the cotter with new ones;
- 2) Tighten the mast locking bolts to proper torque. (refer to the maintenance data)
- 3) Lubricate all pins.
- 4) If assembly and disassembly affects the tilting angle, check and adjust the tilting angle.

3.3 Operation

3.3.1 Starting check

⚠ CAUTION

Do not operate the truck until all checks are done.
If there is any abnormal, report to the manager and do not operate the fault truck until it is repaired.

Carry out the starting check for safety.
Refer to 4.2 Starting check for detail.

3.3.2 Getting on and off the truck and operation posture adjusting

■ Getting on and off the truck

⚠ CAUTION

Get on or off the truck until the truck is stopped well.
It is prohibited to jump on and off the truck.
Do not grasp operation lever and steering wheel when getting on or off the truck.
Keep the handle and steps clean. And if damaged, repair it.
Do not use the handle in other applications except when getting on or off the truck.
Get on or off the truck from the left side.
Support yourself at least in three points with hand and foot when getting on or off the truck. Step on the step(3), grasp the handle with left hand (1) and grip the seat back or seat(2) when getting on and off.

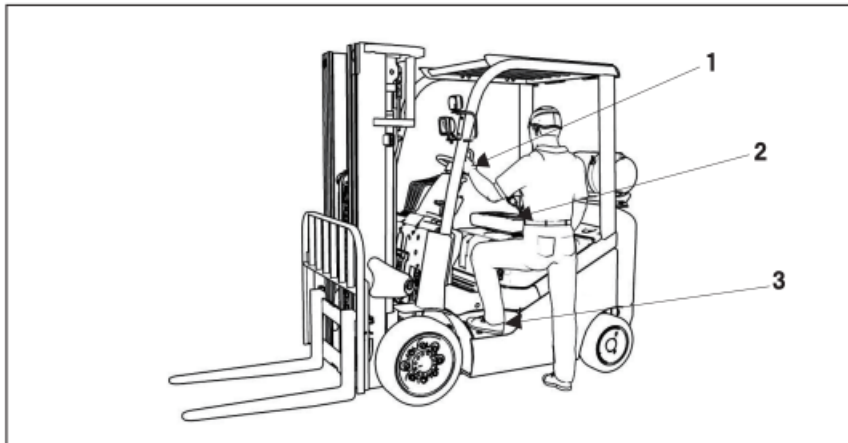

■ Seat position adjusting

 CAUTION

Adjust the seat position before getting on the truck or changing a driver. (Adjust only the truck is well stopped.

Make sure you can step the brake pedal fully when you lay against the seat.

1. For truck parking, refer to 3.3.8 STOPPING FOR A WHILE for detail.
2. Pull the knob to the right side when sitting on the seat. (on this position, operator can slide forward or backward when sitting on the seat.
3. Lose the knob until the satisfied position is found and then the seat is locked.
4. Pull the seat forward or backward after adjusting to make sure the seat s locked.



Seat back angle adjusting:

1. Rotate the knob right, the angle is increased and the back turn towards back.
2. Rotate the knob left, the angle is decreased and the back turn towards front..



Suspension adjusting

Adjust the suspension level through adjusting knob. Pull the knob upward if the operator is light. Push the knob downward if the operator is heavy. Place the knob in middle position if the operator is moderate.

Weight adjusting range: 50-120kg.

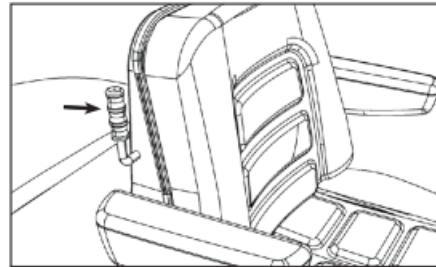

■ Fasten and lose the safety belt

 CAUTION

Wear safety belt during operation.

1. Insert the spring bolt on the left side belt to the lock on the right side. Safety belt is locked when you hear a click.
2. Hold the safety belt with left hand and press the red button on the lock with right hand when loose the belt.
3. Hold the spring bolt to roll the belt slowly.

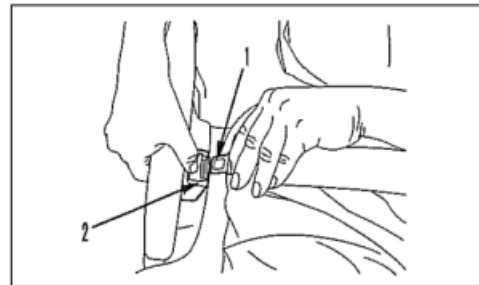
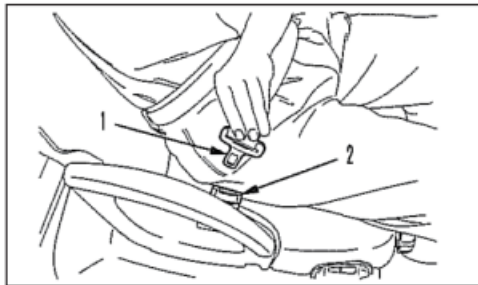

■ Steering hand wheel position adjusting

CAUTION

Park the truck well before adjusting the steering hand wheel position.
After adjusting, move the steering hand wheel forward and backward to check if it is locked.

1. Stop the truck.;
2. Lift the steering wheel lock lever to A position;
3. Move the steering wheel forward and backward to choose proper position;
4. Push the steering wheel lock lever to position B to lock the steering wheel;
5. After adjusting, check if the steering wheel is locked well.

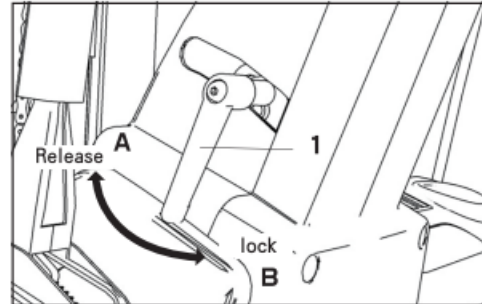

3.3.3 Starting, gear shifting and travelling

■ Engine starting when it is powered by gasoline (double fuel truck model)

CAUTION

Never try to make the engine starting circuit short circuit on purpose to start the engine, or serious injury or fire may be caused.

CAUTION

Start the engine only when the driver sits on the seat.
Before starting the engine, place the forward/backward operation lever and high speed/low speed lever on neutral position and push the parking brake backward.
Keep the working area well ventilated when starting the engine inside or in a poor ventilated place because the exhausting air is poison.
If the truck is operated with such posture (the seat does not bear your whole weight, for example stand or lean against forward, backward or side when operating), the power to engine will be cut and the truck may slide down. In that case, accidents or collision may occur. Keep proper posture when going on a slope. (Truck with OPS seat)

1. Place forward/backward operation lever on neutral position.

Note: Engine can not be started unless the forward/backward operation lever is placed on neutral position.

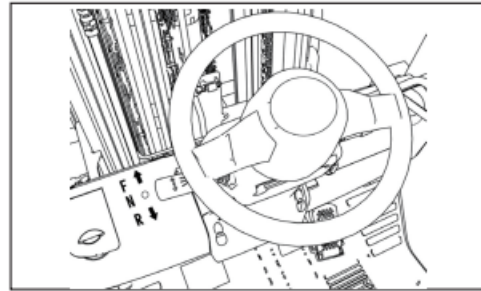

2. Releasing the parking brake

When releasing parking brake, pull the handle back and press down the button on top of the handle at the same time. Then press the button and push the handle forward at the same time to make the handle to be placed at the very leading position.

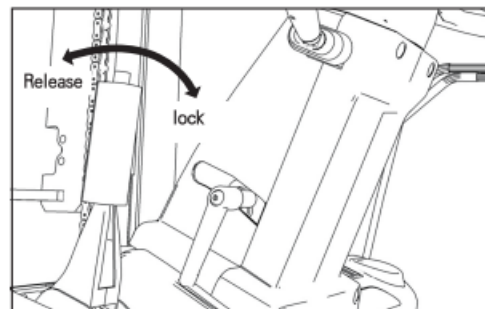

3. Place the fuel selecting switch to the GAS position.

4. Step on the inching pedal.

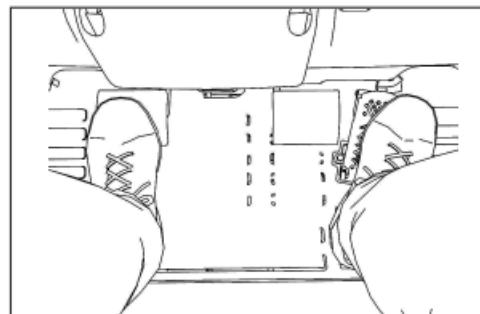

5. Starting switch operation

Turn the starting key switch to the START position (II) when your foot move away from the acceleration pedal and then the engine will be started.

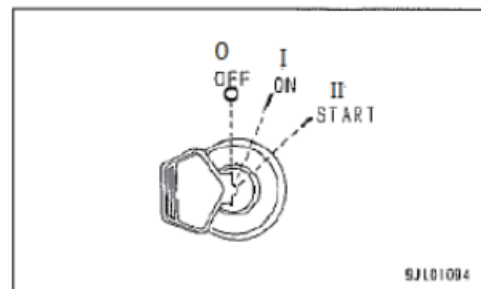

The starting key switch will go back to the ON (I) position automatically when undo the engine starting key switch as soon as the engine is started. When the engine is working, make sure the key stays at the position.

■ Starting engine

1. Place forward/backward lever on neutral position.

Note: Engine can not be started unless the forward/backward lever is placed on neutral position.

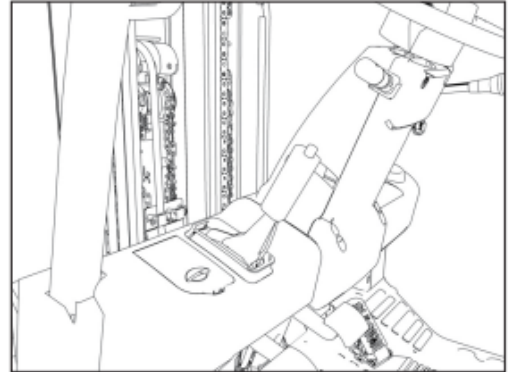

2. Pull the parking brake lever to the lock position.

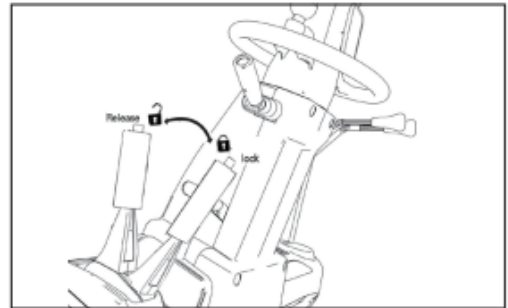

3. Turn on the releasing valve fully (Rotate in anti clockwise direction.)

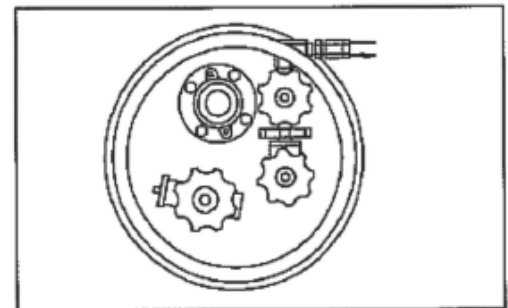

5. For hydraulic powered truck, please step on the inching pedal.

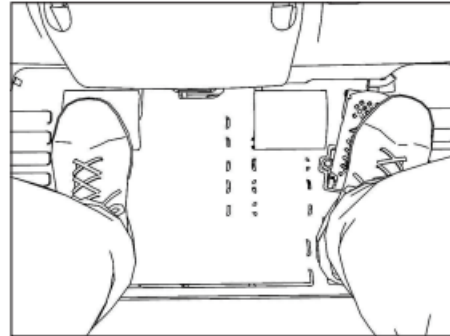

6. Starting switch operation

Turn the starting key switch to the START position (II) when your foot move away from the acceleration pedal and then the engine will be started.

The starting key switch will go back to the ON (I) position automatically when undo the engine starting key switch as soon as the engine is started. When the engine is working, make sure the key stays at the position.

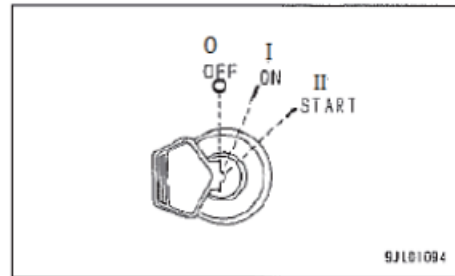

NOTE: • because of the vaporization of LPG, water accumulated on the vaporizer will frozen during the vaporization of LPG and engine will be out of work. When the frozen ice melt, start the engine again.

IMPORTANT

- Keep the starting key switch on OFF (0) position when the engine is not working. Do not keep it on ON (I) position or battery quality will be reduced which causes the engine be hard to be start.
- Do not make the starting motor work over 10s. (*)
- Operate the starting motor again after 20s. (*)
- When the engine is working, do not turn to starting key switch to the START (II) position.

■ Drive the truck

1. Step on the inching pedal and place the forward/backward operation lever to the forward (↑) (F) or (↓) (R) position.

2. Releasing the parking brake

When releasing parking brake, pull the handle back and press down the button on top of the handle at the same time. Then press the button and push the handle forward at the same time to make the handle to be placed at the very leading position.

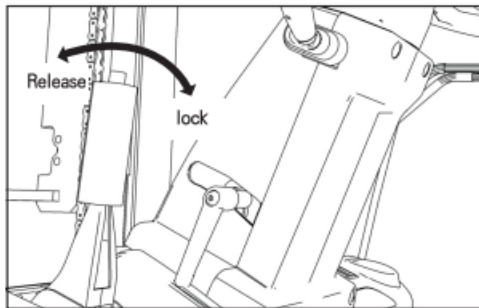
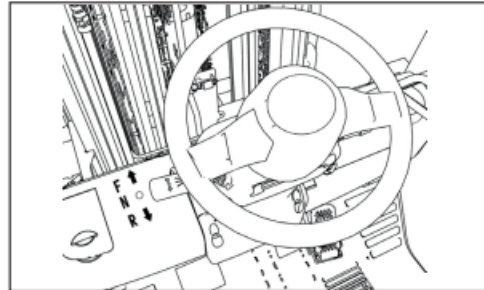

IMPORTANT:

If the parking brake is not released when the truck is traveling, the brake will overheat and worn. What is more, the brake function will be affected.

Contact your EKKO dealer or agent for check if the truck travels with parking brake applied for long distance.

3. Check the safety around the truck and in the travelling direction.

4. Slowly release the inching pedal (4) when you softly step on the acceleration pedal, and then the truck will travel. Once it begins to travel, move your foot away from the inching pedal (4).

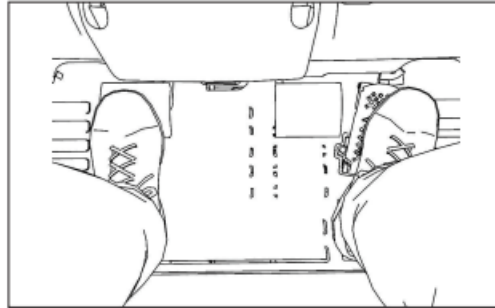

IMPORTANT

Do not stay on the inching pedal or brake pedal unless it is necessary.

■ OPS

- If the seat does not bear your whole weight, for example stand or lean against forward, backward or side when operating, the safety device will prevent the truck from working. If you operate the truck with such posture, the OPS will be activated in 5s and transmission box power will be cut. In that case, the truck can not move even acceleration pedal is pressed or forward/backward lever is operated.
- When the OPS is activated, the OPS indicator on the meter will light on.
- Return to travel condition: sit on the seat with proper posture and place the forward/backward lever on neutral position and then the truck will be ready for travel. Ensure the safety around.
- The OPS only cut the power but not put the brake into effect.



■ Direction changing

1. Release the acceleration pedal (1) and step on the brake pedal (2).
2. Before truck stopping completely, shift the forward/backward operation lever to (↓)(R) position from (↑)(F) position.

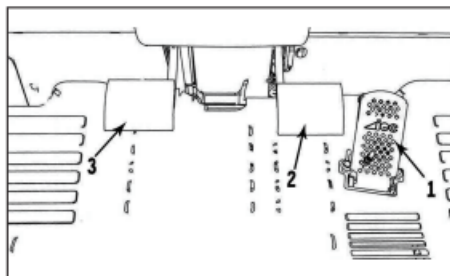

IMPORTANT

Change the direction only when the truck is completely stopped.

- Stop the truck
 - Stop the LPG powered truck
1. Place the forward/backward lever (1) on neutral position.

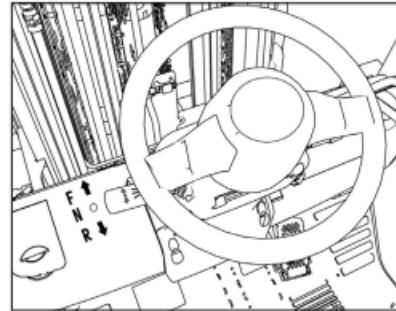

2. Pull the parking brake to the lock position.

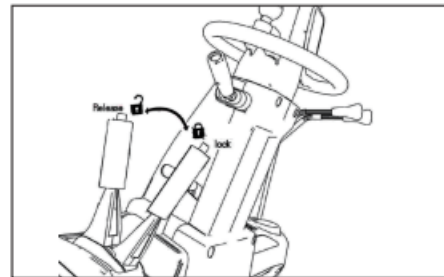

3. Keep the engine running for 5 minutes at an idle speed for cooling.

4. Turn off the releasing valve (rotate in clockwise direction) and wait until the engine is stopped naturally.

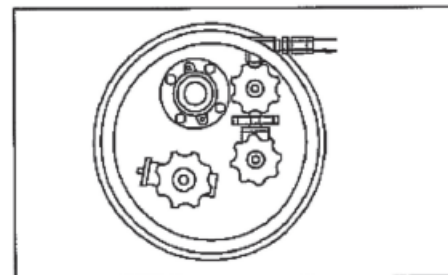

Note: the engine will stop until the LPG remained in the pipe is used up.

5. Turn the key switch to OFF position.

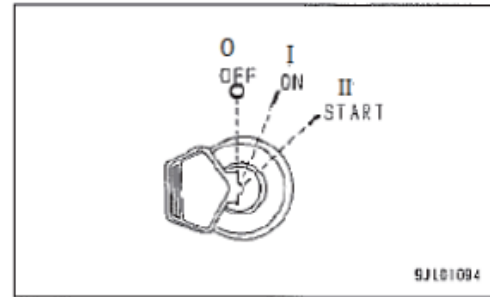

6. Draw out the key switch and leave.

Note: if the parking brake is unlocked when leave the truck, the alarm will sound up. (Optional)

Important:

- If the engine is stopped when it is hot, its service life will be badly affected. Do not stop the truck emergently unless necessary.
- If the engine is hot, do not stop suddenly. Stop it in idle speed.

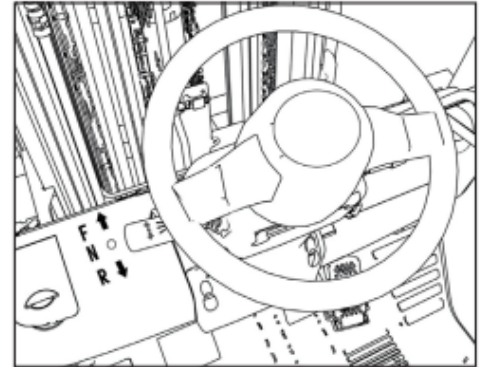

● Stop the gasoline powered truck

1. Place the forward/backward lever (1) on neutral position.

2. Pull the parking brake to the lock position.

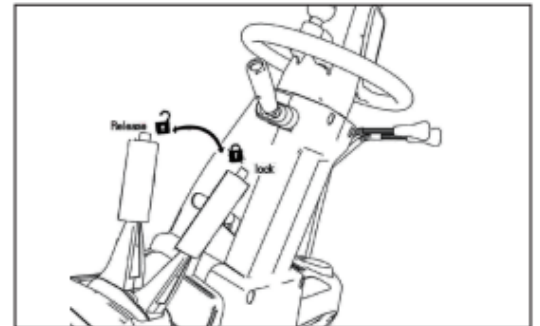

3. Keep the engine running for 5 minutes at an idle speed for cooling.

5. Turn the key switch to OFF position.
6. Draw out the key switch and leave.

Note: if the parking brake is unlocked when leave the truck, the alarm will sound up. (Optional)

Important:

- If the engine is stopped when it is hot, its service life will be badly affected. Do not stop the truck emergently unless necessary.
- If the engine is hot, do not stop suddenly. Stop it in idle speed.

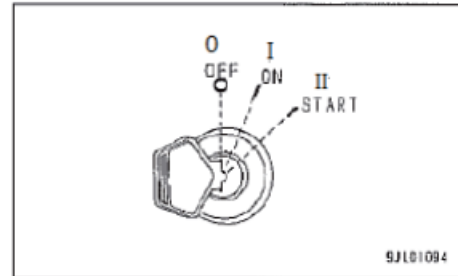

3.3.4 Start and stop on a slope

1. Apply the parking brake when starting on a slope.
2. Slowly release the parking brake when pressing the acceleration pedal (1) increasingly, and then the truck can go uphill.
3. Release the parking brake completely when truck reaches certain speed. The going uphill speed can be controlled by the pressing distance of the acceleration pedal.
4. When stop or deceleration on a slope, release the acceleration pedal (1) slowly and step on the brake pedal at once before stopping.
5. Apply the parking brake when the truck is stopped.

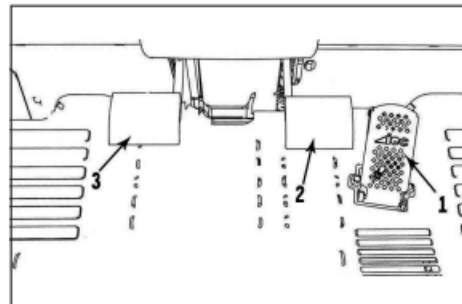
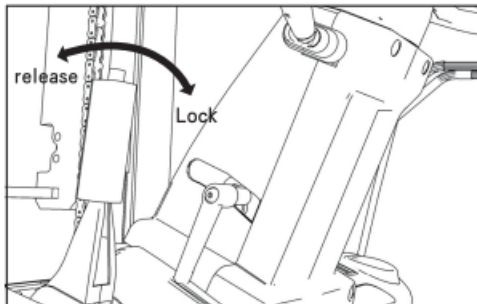

3.3.5 Inching

 **CAUTION**

Do not make the truck inching through stepping on the acceleration pedal and adjusting brake pedal pressing distance.

Make the truck inching through inching pedal.

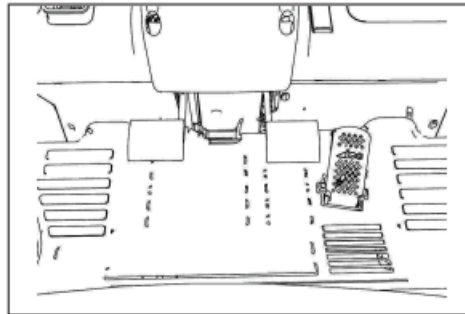

3.3.6 Steering

 **CAUTION**

When steering, take care that the external side of the counter weight may collide with the person or object around.

The rear wheel is steering wheel. if it travels forward when steering, it is near the insides; if it travels backward when steering, it is near the outside.

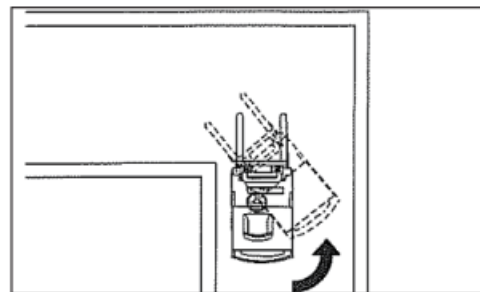

NOTE

- Turning fixedly will accelerate the wear of the tyres.
- Steering with low speed is good for tyre.

3.3.7 Operate on snow field and icy field

 CAUTION

Slipping can not be prevented completely even the truck is assembled with anti-slipping tyre or chain.

Some model may not be suitable to assemble anti-slipping tyre or chain.

- When travelling on snow or icy field, assemble anti-slipping tyre or chain.
- Avoid sudden brake, acceleration or steering on snow or icy field. Take care to operate acceleration pedal in case of slipping.

3.3.8 Truck deceleration and braking

 CAUTION

Park the truck away from the traffic area.

1. hydraulic-powered truck: release acceleration pedal and press the brake pedal (1).

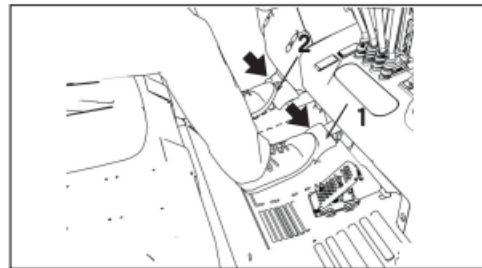

2. Apply parking brake after the truck is stopped. Before it is completely stopped, place the forward/backward operation lever to neutral position.

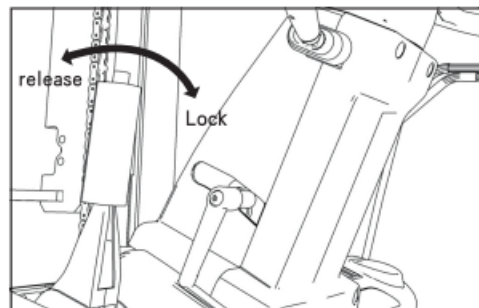

■ Truck parking procedures

1. Park the truck on flat ground.
2. Apply parking brake.
3. Place the forward/backward operation lever on neutral position.

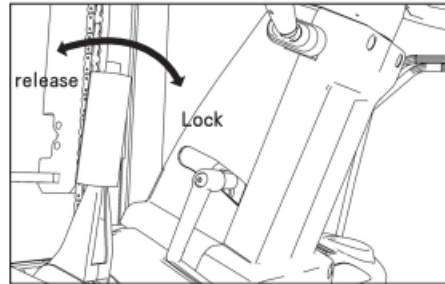

4. Tilt the mast forward and lower the fork to the ground.
5. Turn the starting key switch to OFF (0) position.
6. Draw out the key and go away from the truck.

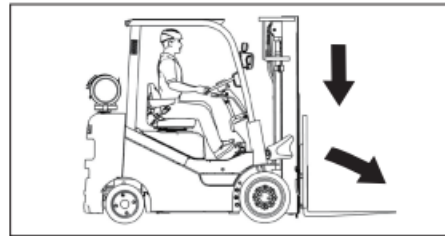

3.3.9 Fuel changing (double fuel truck model)

- Change the fuel type from LPG to GAS(gasoline)
Do according to the following steps:

1. Place the forward/backward lever (1) on neutral position.

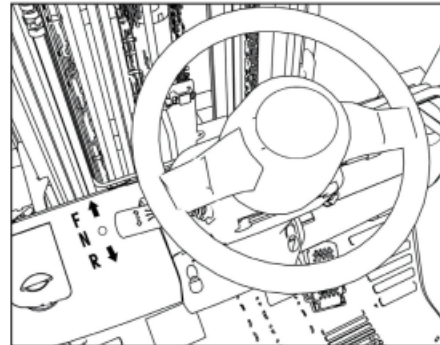

2. Pull the parking brake to the lock position.

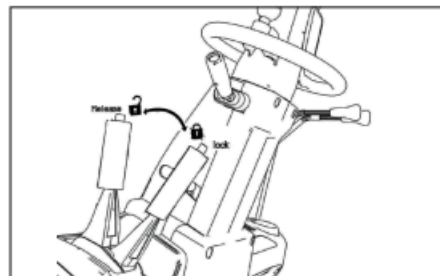

3. Turn off the releasing valve (rotate in clockwise direction) and wait until the engine is stopped naturally.

Note: the engine will stop until the LPG remained in the pipe is used up.

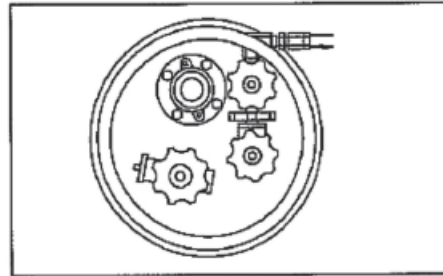

4. After the engine is stopped, turn the key switch to OFF position.

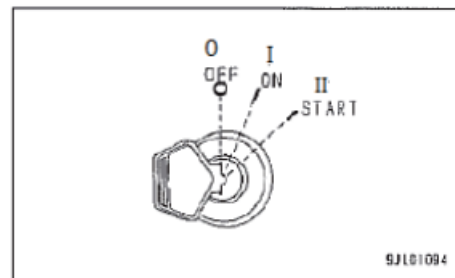

5. For hydraulic powered truck, step on the inching pedal.

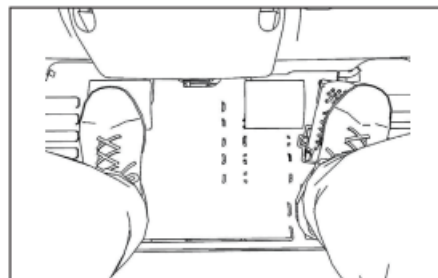

6. Starting switch operation

Turn the starting key switch to the START position (II) when your foot move away from the acceleration pedal and then the engine will be started.

The starting key switch will go back to the ON (I) position automatically when undo the engine starting key switch as soon as the engine is started. When the engine is working, make sure the key stays at the position.

- change the fuel type from GAS to LPG

Do according to the following steps:

1. Place the forward/backward lever (1) on neutral position.

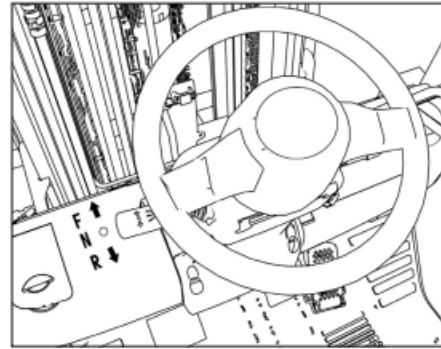

2. Pull the parking brake to the lock position.

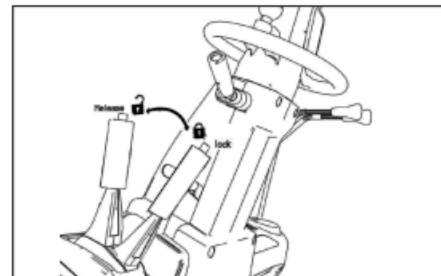

4. After the engine is stopped, turn the key switch to OFF position.

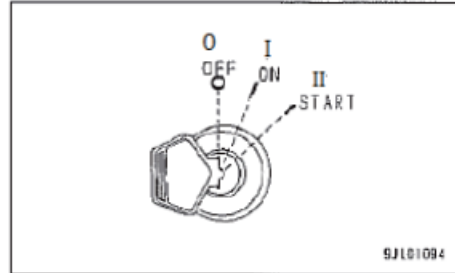

5. Turn on the releasing valve (rotate in anti clockwise direction)

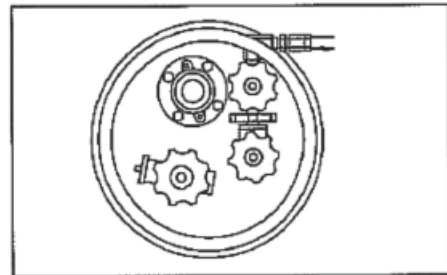

6. For hydraulic powered truck, step on the inching pedal.

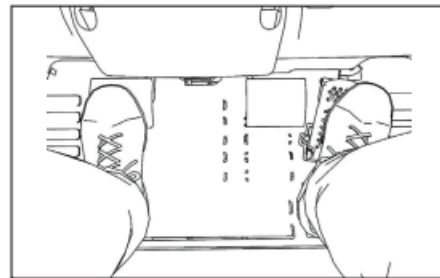

7. Starting switch operation

Turn the starting key switch to the START position (II) when your foot move away from the acceleration pedal and then the engine will be started.

The starting key switch will go back to the ON (I) position automatically when undo the engine starting key switch as soon as the engine is started. When the engine is working, make sure the key stays at the position.

3.3.10 Load handing operation

■ Space between fork adjustment

Adjust the space between the fork before loading to suits pallet size and loads.

 CAUTION

Take care not to make hand or finger be caught when adjusting.

1. Stop the truck right before the loads.
2. Make the mast be vertical and lift the fork 10cm above the ground.
3. Tilt the mast forward.
4. Lift the fork stopper and rotate 90° to releasing position. (fork can move left or right under this condition.)
5. Adjust the space between fork according to loads size and align the loads center of gravity with the truck.
6. Make the mast be vertical and rotate the stopper 90° to the lock position. (At this time, fork is locked.)
7. After space adjusting, check if the fork is locked by stopped. If not, the fork may move towards two sides and goods may fall down when travelling.

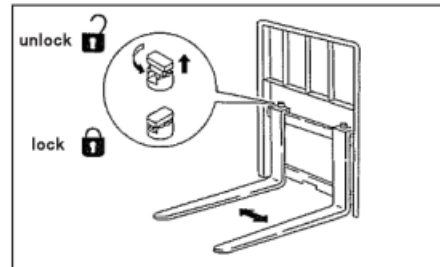

■ Operation lever

 CAUTION

Sit on seat properly and ensure the safety around when operating lifting operation lever. Improper operation and even serious injury may be occur if operating with improper posture or operating outside of the cab.

Lifting operation lever
Lifting: press the operation lever downward.
Lowering: push the operation lever upward.

NOTE
Lifting and lowering speed can be adjusted by the operation lever tilting degree; lifting speed can be adjusted by the pressing distance of the acceleration pedal.

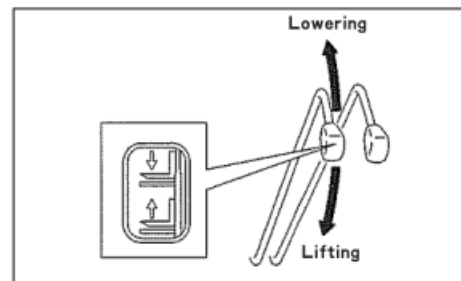

Tilting operation lever

Tilting forward: push the operation lever upward

Tilting backward: press the operation lever downward

NOTE

The fork forward and backward tilting speed can be adjusted by the operation lever tilting degree and pressing distance of the acceleration pedal.

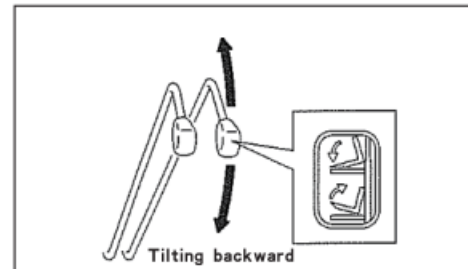

Load picking

1. Insert the fork to the load bottom.
2. if it can not be done once, drive the truck forward until 2/3-3/4 of the fork is inserted into the pallet. Then lift the load 5-10cm and drive the truck backward 10-20cm. At last, lower the load and drive the truck forward until the fork is inserted to the pallet completely.
3. Lift the load 5-10cm and drive the truck backward to where load can be lowered.

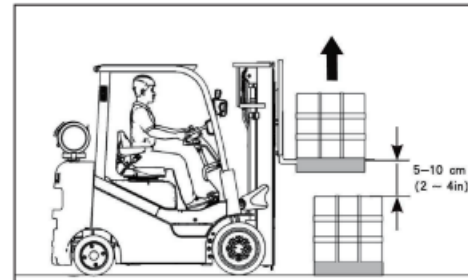

4. Lower the load to be 15-20cm above the ground and tilt the mast backward.

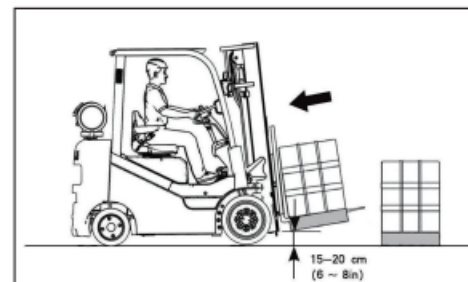

Stacking

1. Make the mast be vertical and lift the fork to be 5-10cm higher than stacking position. And then move the truck forward slowly.
2. Put the truck on desired position.
3. Draw the fork out.

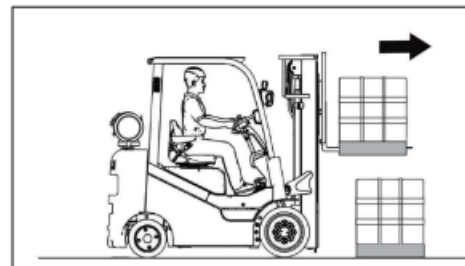

3.3.11 LPG charging

Warning

Change the LPG cylinder in well ventilated place and be away from open fire.

Notes

The LPG cylinder for the truck must confirm to GB 17259 LPG cylinder for automotive vehicle and regulations for cylinder safety supervision. LPG for the truck must confirm to GB 19159-2012 and other relative standards. Charging must be carried out by professionals.

■ Charging through changing LPG cylinder

Warning

- LPG cylinder is installed on cylinder bracket and check if cylinder is locked safely.
- Push the cylinder slightly after it is locked by safety switch and make sure it is locked safely.
- Push the cylinder slightly after it is locked by safety lever and make sure it is locked safely.

Forklift truck with rotating steel cylinder bracket
1. Turn off the releasing valve.

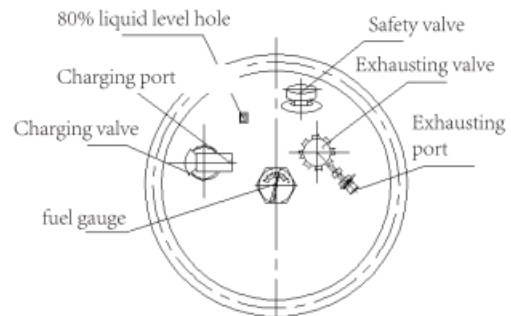

2. Loose LPG cylinder connecting bolt (2) and remove the high pressure pipe to the engine(3).

3. Loose two lock plate (4) and then remove the cylinder from the bracket (5).

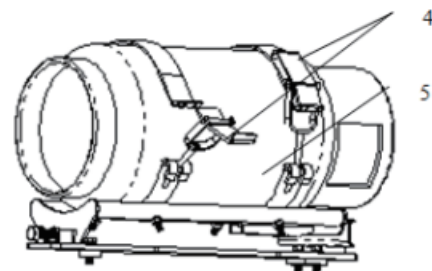

4. Replace the cylinder with a full one.
5. Push the lock plate (4) until it is locked. Push the LPG cylinder slightly (5) and check if it is safely locked.
6. Tighten the LPG cylinder connecting bolt (2) and connect the high pressure pipe (3) to engine.
7. Turn on the releasing valve fully (1) and check if LPG leaks from high pressure pipe (3).

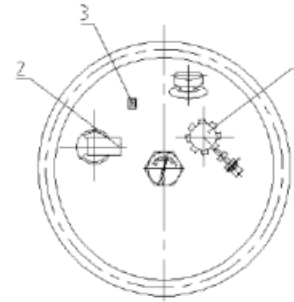

Forklift truck with rotating and tilting steel cylinder bracket

1. Turn off the releasing valve (1).
2. Loose LPG cylinder connecting bolt (2) and remove the high pressure pipe to the engine(3).

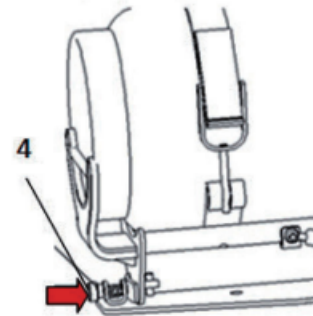

3. Pull the right side safety lever(4) to the right side and then swing the LPG cylinder (5) to the left side.

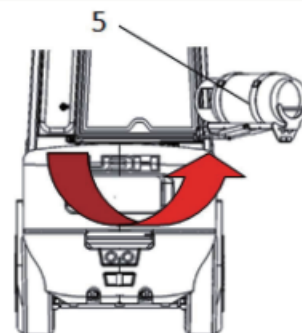

4. Pull the LPG cylinder bracket safety switch (6).

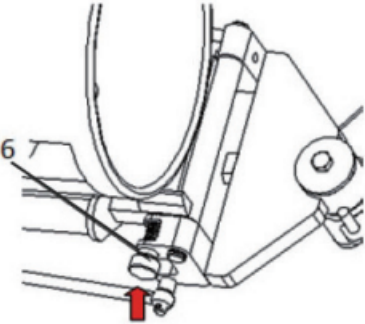

5. Lay down the LPG cylinder (5) and loose two lock plate (7). Then remove the cylinder (5) from bracket.

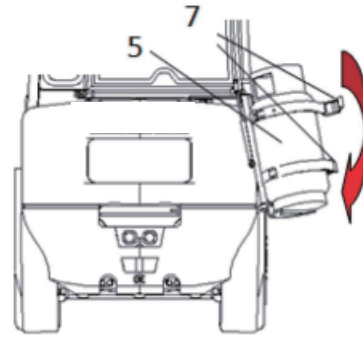

6. Replace the cylinder from the bracket and keep the cylinder valve side up. When installing cylinder, the side with valve must be kept up.

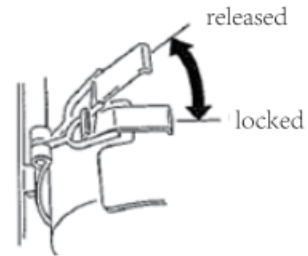

7. Put LPG cylinder (5) on bracket and push the lock plate (7) to the lock position. Push the LPG cylinder slightly (5) and check if it is safely locked.

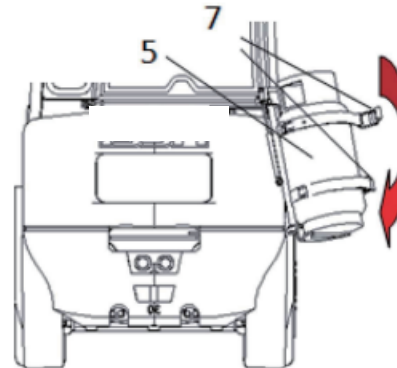

8. Uplift the cylinder (5) and bracket.

9. Pull out the safety switch (6) and make it align to the hole on the bracket. Insert the switch (6) to the hole. Push the LPG cylinder bracket slightly and check if it is safely locked.

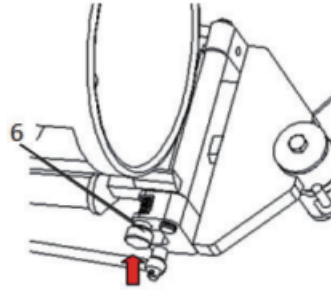

10. Swing the LPG cylinder (5) to the right side and lock with safety lever (4). Push the LPG cylinder (5) slightly and make sure the cylinder is locked safely.

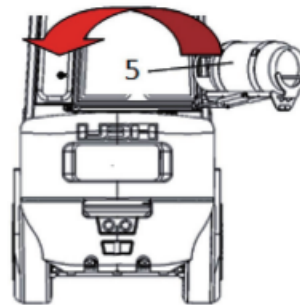

11. Tighten the LPG cylinder connecting bolt (2) and connect the high pressure pipe (3) to the engine.

12. Turn on the releasing valve (1) and check if LPG leaks from high pressure pipe (3).

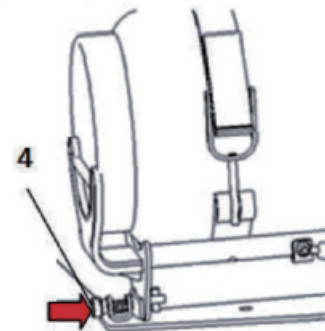

■Charging without changing cylinder

1. Drive the truck to the LPG charger.
2. Turn off the releasing valve (1).
3. Remove the charging port plug (2) and connect with the charger through LPG pipe.
4. Open the 80% liquid level hole and valve on the charger to fill LPG to the cylinder.
5. Charge the cylinder until there is white vaporific LPG gas belching out, then stop charging.
6. Turn off the 80% liquid level hole (3) and the valve on the charger.
7. Disconnect the charger and cylinder and put the plug (3) into the charging port again.
8. Turn on the releasing valve (1).

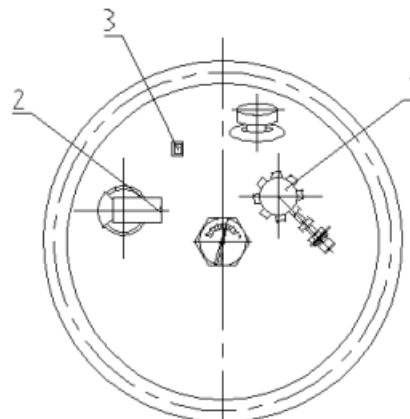

3.3.12 Check after operation

Carry out all checks described above and clean the truck. Before storing, carry out the checks below:

1. Check if there is leakage of fuel, battery and electrolyte.
2. Check if there are any cracks or damage.
3. If there is any fault, report it the manager and place a mark or sign on the truck. (if necessary)
4. Lubricate the truck if necessary.

Refer the following points for other information:

- Refer to 4.6 WORKING IN COLD WEATHER for notes when working in cold weather.
- Refer to 4.7 MEASURES OF ENGINE OVERHEATING for measures when the engine is overheating.
- Refer to 4.11 STORING FOR A LONG TIME for storing for a long time.
- Refer to 4.13 LOADING AND UNLOADING for relative operation.

3.4 Transporting

Refer the technical parameter for truck size and weight.

Refer to the following figure for truck center of gravity. For more information, please contact with HELI dealer.

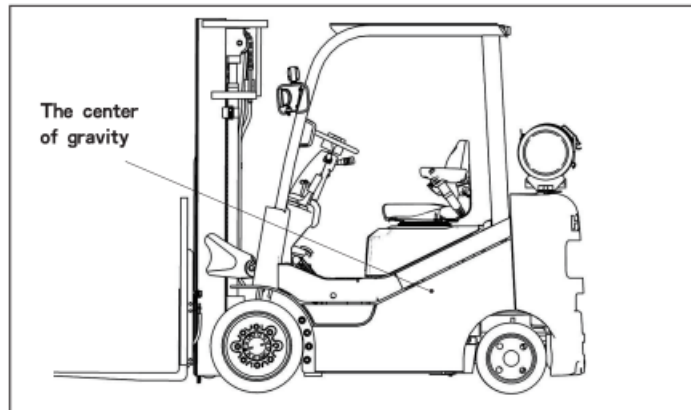

3.4.1 Truck fixing

CAUTION

Authorized transporting company is recommended to transport the truck through highway, railway and waterway.

No matter which method is chosen to transport the truck, a common fixing method is needed which can reduce the truck and paint damage possibility.

Forklift truck fixing method on a lorry:

1. Keep a proper distance (at least 10cm) between two trucks for safety during transporting.
2. Put a wood block under the rear axle surface avoiding a bad effect on rear wheel because of the large gravity of counter weight. Apply the parking brake.
3. Bind the truck carefully avoiding appearance damage. Avoid direct contact with the rope. Put a rag on each binding point.
4. when binding, chose the position which can bear large force. Usually, chose the center beam as the front fixing point and hole on the counter weight as the rear fixing point.
5. The steel rope and iron wire must not interfere with the truck important parts such as tilting cylinder, lifting cylinder avoiding deforming because of force.
6. Fix the truck according to the sketch map below in order to bear small force.
7. In principle, place the truck facing opposite the lorry travelling direction. Because a spin may be caused during travelling if center of gravity is moved to one side. According to practical condition, placement of facing the lorry travelling direction and opposite the travelling direction can be mixed. Be sure to fix the load firmly.
8. After arriving, loose the fixing steel rope when unloading. Then lift the counter weight with lifting equipment and remove the wood block. At last the truck can be driven.

Forklift truck fixing method in a container:

1. For container space limit, trucks position is compact. The min. distance between the two trucks is 20-30mm to ensure disconnecting with each one.
2. Protect the left and right sides of the frame and counter weight with felt pads before going to the container avoiding truck appearance damage.
3. Lift the counter weight with lifting device and put a metal block under it avoiding a bad effect on rear wheel because of the large gravity of counter weight. Apply the parking brake.
4. Wedge the wheels with metal blocks and fix them to the floor board of container for safety.
5. Bind the truck carefully avoiding appearance damage.
6. Chose the lifting holes on top of the mast as front fixing points. For the outside, connect the listing hole with the hook on container. For the middle, connect the two trucks' lifting holes with steel wire. And connect the fork cross beam with the lower hook on the container. Chose the traction pins on the counter weight as rear fixing points. For the outside, connect the pin with the lower hook on the container. For the middle, connect the two trucks' pins with steel wire.
7. When binding, put rag or felt pad to protect the paint on the fixing point from damage.
8. After arriving, loose the fixing steel rope when unloading. Remove the wheel blocks. Lift the counter weight with lifting equipment and remove the metal block. At last the truck can be driven.
9. In principle, trucks should be placed side by side. Placement of facing the travelling direction and opposite the travelling direction can be mixed or placement of facing the travelling direction. Be sure to fix the load firmly.

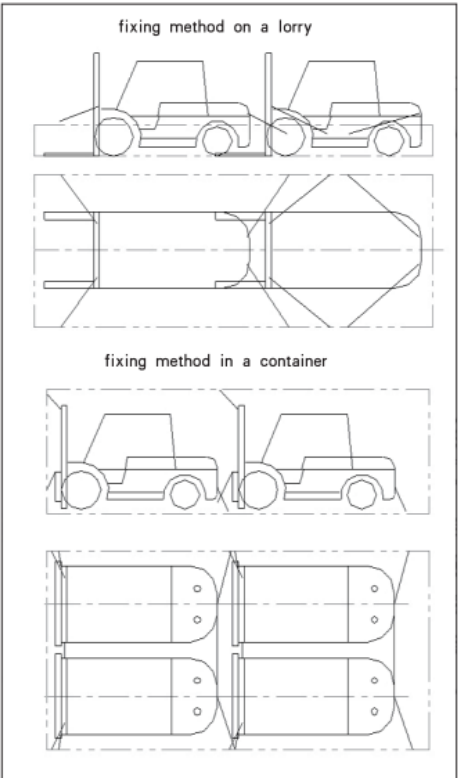

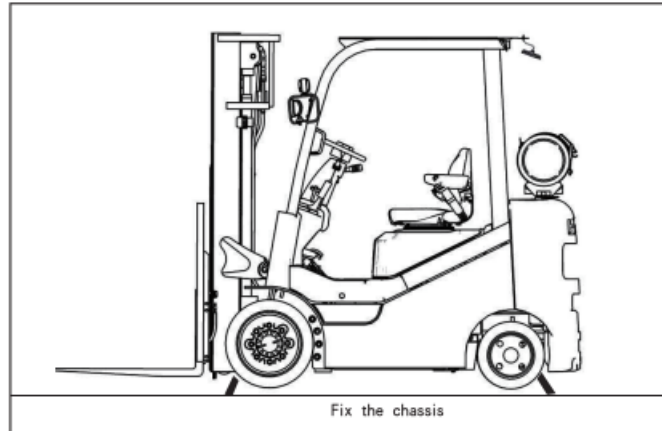

3.4.2 Mast transporting and reassembling

Some mast has to be disassembled during transporting for height limit.

1. Seal the hydraulic pipeline disassembling ends after disassembly. Fix the pipelines with belts. Wrap the connectors and transport with the whole truck.
2. Reassemble the mast after arriving by professionals.

Main technical requirements are followed:

(1) Mast assembly

- a. Check the clearance between the mast and side rollers.
- b. connection between the mast support and frame: apply lubricating grease to bushing. The tighten torque of the mast support bolts: 260Nm. Apply anaerobic adhesive GY-340.
- c. Assembly of the tilting cylinder ear fixing bolts: tighten torque 120Nm. Apply anaerobic adhesive GY-340 (do after mast tilting angle adjustment and check).
- d. The connection and moving trend of pipelines are reasonable. Fix the pipeline with clamps

(2) After mast assembly

- a. Check the mast tilt angle referring to the parameters;
- b. Adjust the chain tension after reassembly.
- c. The pipeline can not interfere with the mast moving.

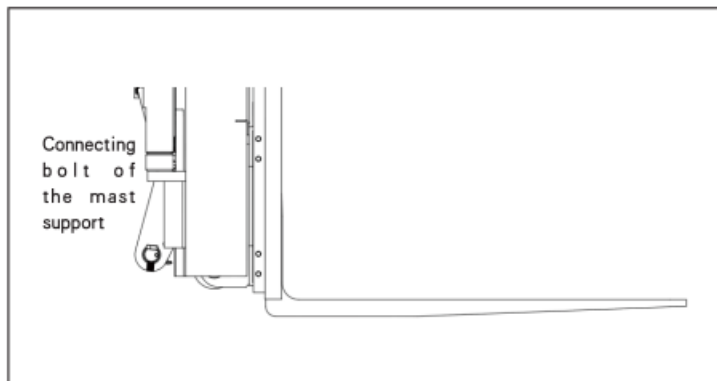

Connecting bolt of the mast support

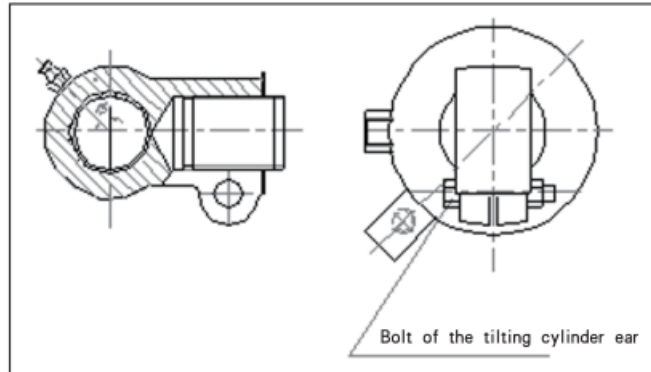

The disassembled mast usually is transported through horizontal method. Place the mast into the container vertically by special clamp in particular. When loading, refer to the practical space. Fix the mast to the middle hook in the container. Block the connecting point between mast support half and the floor board avoiding damage to the container floor.

■ Electricity and hydraulic connection

Block all connecting points of the electricity and hydraulic system in disconnecting condition.

Lifting

The lifting plate shown in the figure shows the proper lifting points. The points are on the mast and counter weight.

For more information, contact with HELI dealer or agent.

IMPORTANT

Make sure all slings have the safe capacity to lift up the truck.

Make sure the mast is under vertical condition before lifting up the truck.

■ Lifting the truck

Put proper lifting equipment on the lifting points.

1. Put sealing material where the lifting equipment may connect the truck avoiding appearance damage.
2. Tighten the slack rope and be away from the truck.
3. Carry out one lifting test to ensure balance lifting. If not, lower to the ground and adjust the lifting equipment.
4. If all above descriptions are correct, lift the truck to required position slowly.
5. Place the truck to required place and remove the lifting equipment.

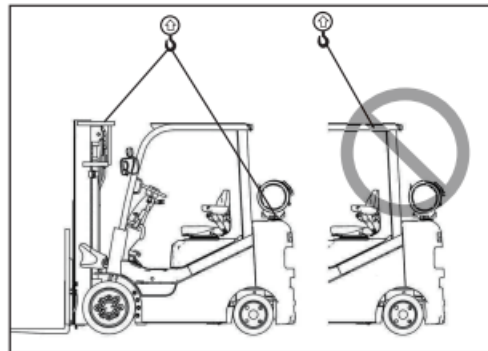

Sling plate

CHECKING AND MAINTENANCE



WARNING

Please read the manual and safety notes carefully.

When checking and maintaining the truck, please follow the safety notes or serious injuries may be caused.

4.1 About checking and maintenance

Starting check, oil change, filter cleaning and other simple maintenance work are described below. For others that are not described, contact with HELI dealer or agent.

Refer to the second chapter SAFETY NOTE for safe checking and maintenance.

Improper maintenance and repair may cause serious accident and shorten truck service life. Please contact with HELI dealer or agent for maintenance and repair.

4.2 Starting checking

CAUTION

- Do not operate the truck before checking.
- If there is any abnormal, report to the manager. Do not operate the truck until it is repaired.

-
- For safety, carry out the starting check before operation.
 - Record checking results in checking record.

Starting checking parts table

Item	Checking parts
-	Check the abnormal found the day before
Forklift truck	Leakage of oil and electrolyte
	Crack, damage and fixing condition (overhead guard, fork, backrest and so on)
	Tightness of the locking nut of the tilting cylinder piston rod
	Check if the light and glass cover are clean or damaged.
	Check if the backview mirror and truck plate are clean or damaged.
	Check the tightness of hub nuts.
	Check if the tyre and rims are damaged or out of shape.
	Check the cylinder valve and fuel level.
Open the engine hood	Hydraulic oil level
	Engine oil level and check if it is dirty.
	Check the tightness of the battery connection.
	Coolant level
	Brake liquid level
Sit on seat	Performance of the safety belt
	Seat and hand shark
	Brake pedal clearance and height
	clearance and height of clutch pedal and inching pedal
	Parking brake operation lever operation force
	Horn
	Cleanness, damage and angle of the backview mirror
Turn the starting switch to ON position	Alarming indicator on the meter (check through switch the starting switch to ON and OFF position)
	Light
	Fuel level
Start the engine	Abnormal noise and vibration
	Exhausting air color
	Hand wheel clearance
	Check if the high pressure pipe leaks.
Drive slowly	Hand wheel operation condition (radial run-out and unstable driving)
	Brake operation condition (respond)
	Inching and clutch pedal operation condition

Item	Checking parts
Load handling	Mast operation condition
	Tightness of lifting chain; check if it is damaged or rust.
Safety function check	OPS
	Parking brake



4.2.1 Check the abnormal found the day before

Check the abnormal found the day before. Make sure there is no fault.

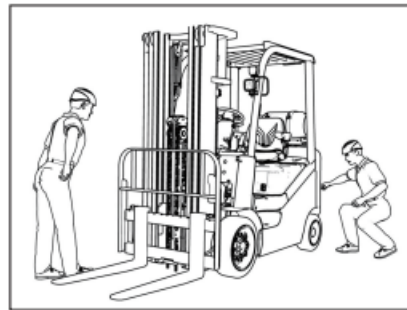

4.2.2 Forklift truck

- Check if there is leakage of oil and electrolyte.
 - Check if there is leakage of oil, fuel, coolant and battery electrolyte.
 - check if there is leakage of oil and electrolyte under the truck.

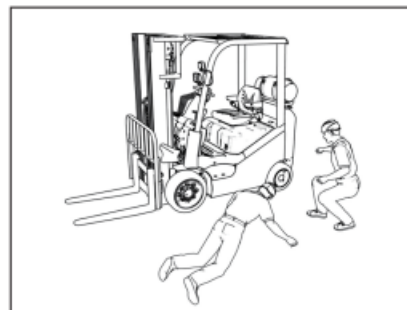

■ Crack, damage and fixing condition check

Check if there is any damage, cracks, loose and clearance through visual check. Check the following parts preferentially:

- Overhead guard
- Fork
- Backrest
- Fork bracket
- Mast
- Fuel tank
- Hydraulic oil tank

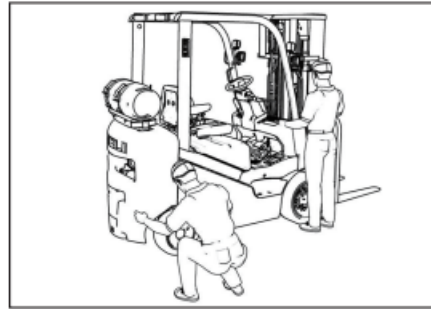

■ Check the tightness of the locking nut of the tilting cylinder piston rod

Check if the tilting cylinder piston rod, piston head and locking nut are loose visually.

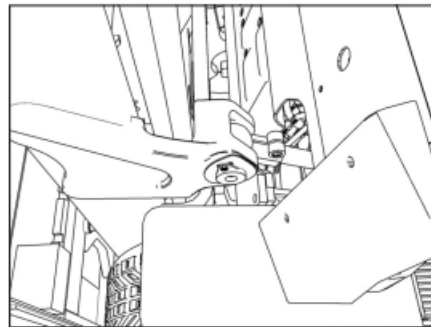

■ Check if the light and glass cover are clean or damaged.

Check if the light and glass cover are clean or damaged visually.

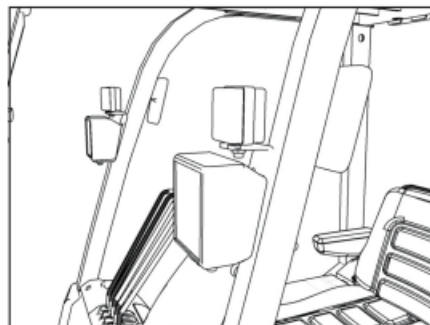

■ Check if the backview mirror is dirty or damaged.
Check if the backview mirror is dirty or damaged visually.

■ Check if the rim nut is loose.

Check if there is loose nut by wrench.

IMPORTANT

Tighten the rim nut to the regulated torque.

For proper tighten torque, refer to 4.16 REPAIR PARAMETER.

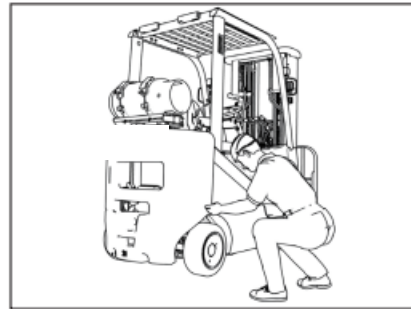

■ Tyre and rim checking

● Check if the tyres are worn, damaged. Check if there is any adhered nail and other foreign matters. Check if the rim is out of shape or damaged.

● If the tyre tread depth is less than 5mm or there is tyre worn alarming mark, change the tyre.

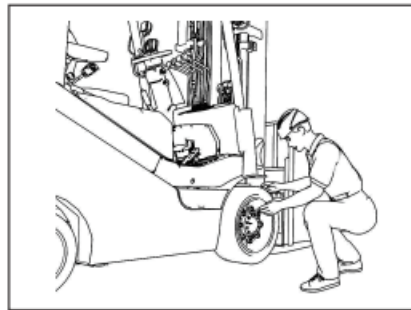

■ LPG cylinder valve and liquid level

● Check charging valve and releasing valve

Make sure the charging valve and releasing valve are turned off.

● Check the LPG level through fuel gauge.

Note: Low level alarm is equipped on the truck. when the LPG level is low, the indicator on the meter will remind the user to charge.

4.2.3 Open the engine hood to check

 **CAUTION**

- Before opening the engine hood, shut off the engine.
- Take care not to press your hand when opening or closing the engine hood.
- Only authorized person is allowed to open the engine hood.

1. Release the hood lock through pushing the hand shank on the left front of the engine hood.
2. Push then engine hood upward until the red stopper of the engine hood supporting gas spring is taken its place.

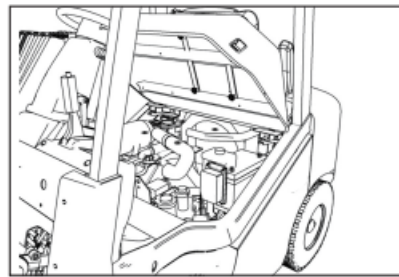
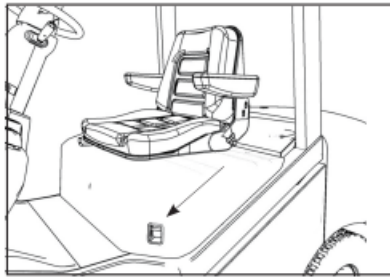

■ Methods of closing the engine hood

- Press the support's red stopper (marked with press) to the direction of arrow (backward) with one hand and close the engine hood with the other hand slowly.
- Check if the engine hood is closed and locked.

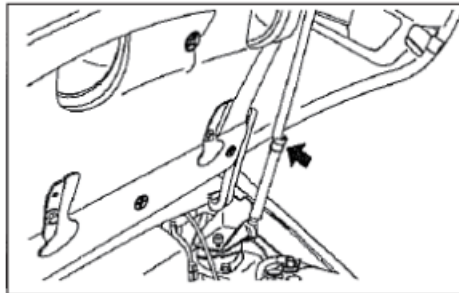

■ Hydraulic oil level check

Check if the hydraulic oil is added to regulated level.

1. Place the truck on a flat ground. Lower the fork to the ground and keep the mast be vertical.
2. Draw out the oil dipstick on the right side of the truck (integrated with the ventilating device). Clean the oil dipstick with rag and then insert it to the oil tank.
3. Draw out the oil dipstick and check if the adhered oil is in normal range.
4. Add oil if oil level is low; if oil run out, clean it.

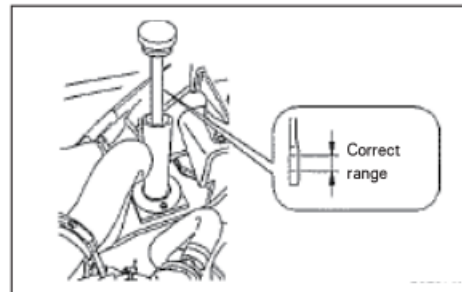

IMPORTANT

Only pure EKKO hydraulic oil or recommended oil can be used.

■ Engine oil level check

1. Check if the engine oil is in normal range.
2. Draw out the oil dipstick on the left side of the truck. Clean the oil dipstick with rag and then insert it to the oil tank.
3. Draw out the oil dipstick and check if the adhered oil is in normal range.
4. Add oil if oil level is low; if oil run out, clean it.

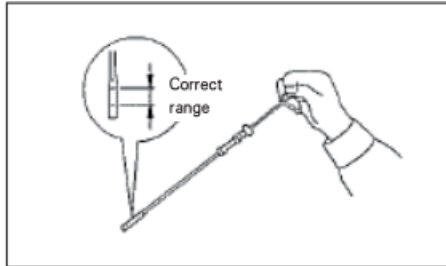

IMPORTANT

If the engine oil is polluted or goes color, change the engine oil.

Only pure EKKO engine oil or recommended oil can be used.

■ Electrolyte level check



CAUTION

Flammable hydrogen produced by the battery is explosive. Dilute sulphuric acid is also contained in the electrolyte. Serious injuries, explosion and fire may be caused if it is handle improperly. Stick the notes described in 2.7.14 NOTES WHEN DEALING WITH BATTERY.

- Keep the ventilation device and battery terminals clean. Make sure there is no adhered dust.

IMPORTEANT

- If the battery electrolyte runs out, replace with the same type electrolyte.

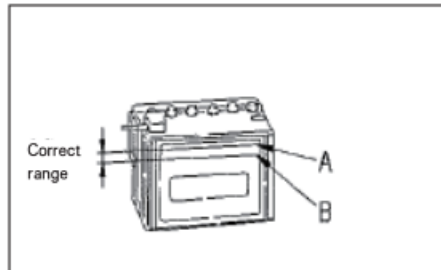

■ Transmission and drive axle oil level check

1. Open the hood and rear floor, check the oil gauge.
2. Check if the liquid stays between the MAX and MIN ,if it is low, add to the upper limit.

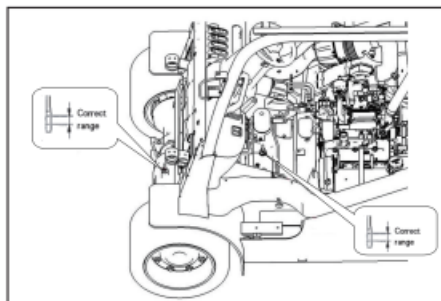

■ Coolant level check

 **CAUTION**

Do not open the radiator cap as soon as the truck is stopped. Because the coolant temperature is very high, burning water may ejected out and burn others. Slowly remove the radiator cap slowly after the coolant is cool.

1. Check if the coolant in the auxiliary radiator stays between the FULL and LOW mark when he coolant is cool.

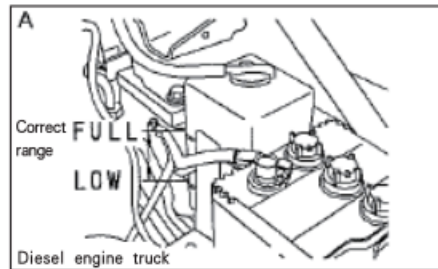

2. If the level is low, add it to the full position.
3. Check if the radiator and radiator hose leak.
4. When the coolant in auxiliary radiator runs over, open the radiator cap and add coolant to the radiator and auxiliary radiator.



■ Check the V belt's deflation

For the V belt tension check, press the middle of the belt with 98N.

The belt deflation should be 10-13mm.

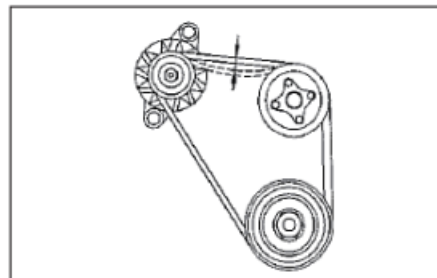

NOTE: Change the belt if it is stretched and there is no adjusting possibility, or it is damaged. Please contact your EKKO dealer or agent for belt change.

4.2.4 Check sitting on the chair

■ Safety belt check

Check the safety belt first.

- Check if the belt and connectors are damaged.
- Check if the belt can be pulled out and withdrawn smoothly; check if the connector can be locked or loosen normally.
- Check if the belt can be locked when pulling suddenly.

■ Check the position of the seat and steering hand wheel.

Check if pedals, operation levers and switches can be operated stably when sitting on seat.

■ Brake pedal check

Check if the brake pedal operation force and pedal distance are correct.

Refer to 4.16 REPAIR PARAMETER for clearance standard value (S1) and pedal height (H) during brake.

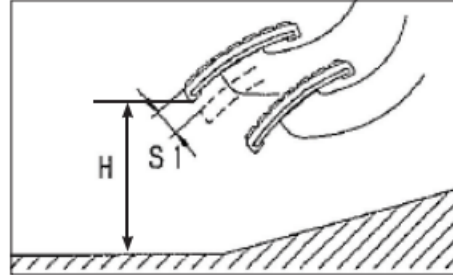

■ Inching pedal check

Check the inching pedal operation force, clearance and interlocking distance. Refer to 4.16 REPAIR PARAMETER for clearance standard value (S2) and interlocking distance (S3).

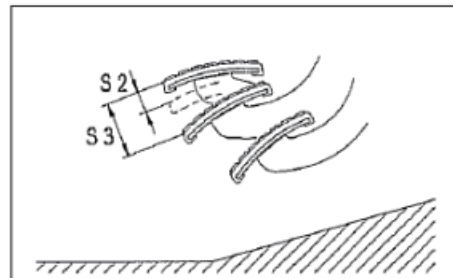

■ Parking brake handle check

Check if the parking brake handle can be pulled back to the lock position; check if the parking brake can be pushed to the released position smoothly. Check if the button can return to initial position smoothly after pressed. For parking brake handle operation force standard value, refer to “parking brake handle operation force adjustment”.

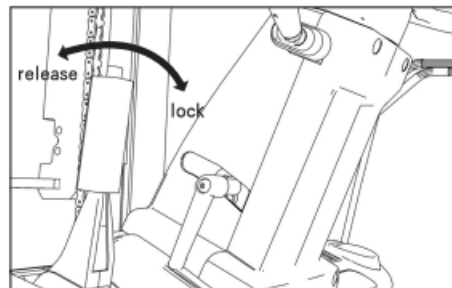

■ Horn check

Check if the horn can sound normally.

■ Rear mirror check

Check if the driver can see the rear view easily from the rear mirror. Check if it is dirty or damaged.



4.2.5 Check when the starting key switch is on ON position

■ Alarm indicator check

When the starting switch stays on ON position, check if indicators (engine oil pressure alarm indicator, engine fault indicator  and no charging alarm indicator) are on.

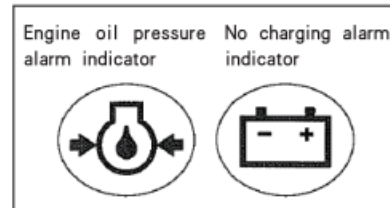

■ Neutral position indicator

If the indicator turns on when the starting switch is on ON position and it turns off when the forward/backward operation lever is on forward or backward position, the neutral indicator is ok.



■ Engine coolant temperature meter

When the engine is cold, the pointer points to the left side and when the engine is preheated, the pointer points to the white range.

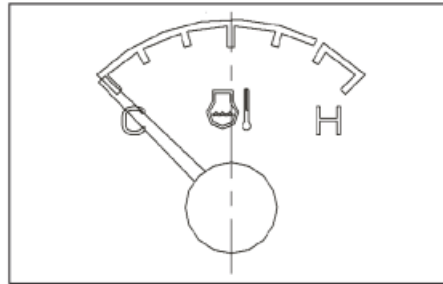

■ LPG low fuel indicator & light

The LPG in the tank almost run out while it light on .you need to adding the LPG following the step described in “3.3.11 LPG charging”

■ Lights check

- Check if the front lamp, contour light, steering signal, brake light and reversing light are normal.

■ 19.LPG level check and adding

- Check the fuel gauge on the top of the LPG tank and make sure it's enough for work . If the pointer points below "E", please follow the “3.3.11 LPG charging” step.

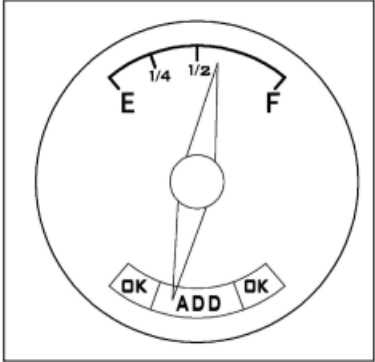

- Back buzzer check
Check if the back buzzer sounds when the operation lever is placed on backward position.

4.2.6 Check when the engine is started



CAUTION

- Take care of the ventilation condition when starting engine indoor or in poor ventilated place because the exhausting air is poison.

■ Alarm indicator on the meter

- Check if the alarm indicator on the meter turns off as soon as the engine is started.
- Engine pressure alarm indicator may turns off a little later. But that does not mean the indicator has fault.

■ Abnormal noise and vibration

- Especially check if the engine and hydraulic pump has abnormal noise and vibration.

■ Exhausting air color

- Check if the exhausting air is black or white.

■ Clearance check

- Rotate the steering wheel to check the clearance. If it is between 10-15°, it is normal.
- Check if it is loose through shake in both vertical and horizontal direction.

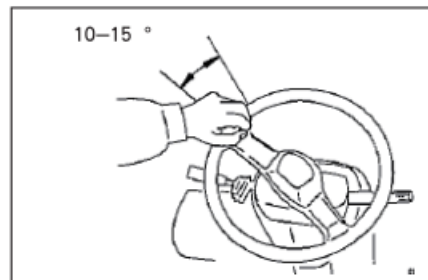

■ Check if high pressure pipe leaks

 **Warning**

If high pressure pipe leaks, turn off the exhausting valve at once and contact with HELI dealer. Keep the truck away from the open fire before technician arrives.
Do as follows to make the LPG flow to the vaporizer inlet port and then check if the high pressure pipe leaks.

1. Turn on the releasing valve.

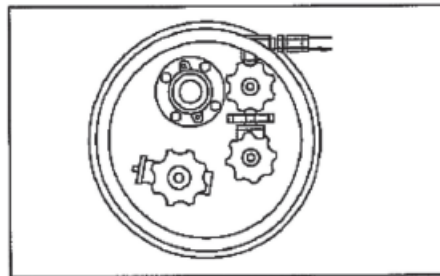

2. Place the fuel selecting switch on LPG position (double fuel truck model).
3. Turn the key switch to ON position and start the engine for a little time.

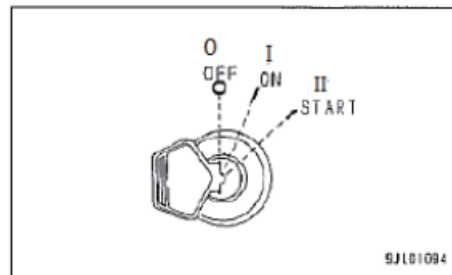

4. Check if the high pressure pipe leaks with leakage checking liquid or soap.

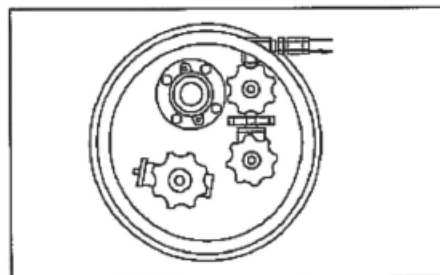

4.2.7 Check when travelling slowly

■ **Steering wheel check**

Check the steering wheel when driving slowly:

- Check if there is clearance;
- Check if the steering wheel is stable in left and right side when driving straightly;
- Check if the steering wheel is heavy or if there is abnormal shake when rotating the steering wheel.

■ **Brake check**

Check the brake respond through stepping on the brake pedal when driving slowly.

- Check if brake can meet the requirements.
- Check if the brake forces on two sides are equal.

■ **Inching pedal check**

Check its function through stepping on the inching pedal when driving slowly.

- Check if travelling speed can be adjusted according to pressure applied on the inching pedal.
- Check if the truck can be stopped completely when the inching pedal is pressed down fully.

■ **Abnormal noise and smell check**

- Make sure there is no abnormal noise and smell when travelling slowly.
-

4.2.8 Check through operating the working devices operation lever

■ **Mast, abnormal noise and smell check**

- Check if the fork can be lifted or lowered smoothly and mast can tilt forward and backward smoothly when operating the levers. Before everyday working, operate the piston fully 2 or 3 times.
- When operating working devices operation lever, make sure there is no abnormal noise and smell.

■ Chain tension check

 CAUTION

- If the chain tension is not equal on left and right side, then the load will be applied on one side. In that case, the chain may be broken and goods may fall down and then truck may tip over.
- Before checking, place the forward/backward lever on neutral position, apply the parking brake, shut off the engine and get down from the engine avoiding truck uncontrolled moving and check person being caught.
- Never put feet under the fork for they may be pressed.

1. Lift the fork 5-10cm above the ground (A).
2. Press the middle of the chain with finger to check if the tension are equal on left and right side.

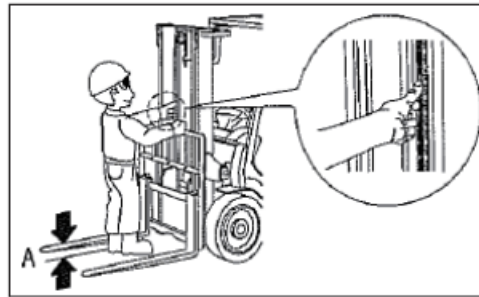

■ Lifting chain check

 CAUTION

- If the lifting chain is broken, the goods may fall down or truck may tip over. If there is any fault with the chain, contact with HELI dealer/agent to replace the lifting chain.
- Rust on the chain is the main cause of chain damage, so keep the chain from rusting in early stage.

1. Check if the chain is damaged, broken or rusted through visual check.
2. Check the lubricating condition. If the chain is rusted or poor lubricated, coat the chain with engine oil.

■ Accessories, abnormal noise and smell check (truck with accessories)

Check the accessories referring to the relative operation manual.

4.2.9 Safety function check

 **CAUTION**

- Park the truck on a flat ground before carrying out the check.
- Make sure there are no people and barriers around and there is enough driving space.

■ OPS (travelling function) check

The truck is not allowed to move by the OPS system when the driver goes away from the seat. Check the safety function.

■ Checking steps

1. Park the truck on a flat and solid ground and apply the parking brake.
2. Place the forward/backward operation lever on neutral position and lift the fork 15cm above the ground.
3. Move foot way from the brake pedal, inching pedal and acceleration pedal.
4. Place the forward / backward operation lever on forward or backward position and move you buttock away from the seat.
5. Check if the OPS alarm indicator on the meter lights on after 5s.
6. Release the parking brake.
7. Make sure the truck will not move when you press the acceleration pedal with buttock away from the seat.
8. Release the OPS (driving function).

Sit on the seat with correct posture and place the forward/backward operation lever on neutral position. The truck will return to normal operation condition and the flickering OPS alarm indicator turns off.

■ OPS (loading function) check

The truck is not allowed to lift by the OPS system when the driver goes away from the seat. Check the safety function.

■ Checking steps

1. Park the truck on a flat and solid ground and apply the parking brake.
2. Place the forward/backward operation lever on neutral position and lift the fork 1m from the ground.
3. Move foot way from pedals and move your buttock from the seat.
4. Check if the OPS alarm indicator on the meter lights on after 5s.

5. Ensure the following points:

Fork will not be lifted or lowered even the lifting and lowering operation lever is operated.

Mast will not tilt forward or backward even the tilting operation lever is operated.

6. Release OPS (loading function)

The truck will return to normal operation condition and the flickering OPS alarm indicator turns off when sitting on the seat with correct posture.

■ Neutral position safety function check

The function is used to avoid truck moving suddenly when starting the engine as the forward/backward operation lever is placed on forward or backward position.

■ Checking steps

1. Park the truck on a flat and solid ground and apply parking brake.
2. Place the forward/backward operation lever on neutral position and shut off the engine.
3. Make sure the starting motor and engine do not work even starting switch is turned to starting position when the forward/backward operation lever is placed on forward or backward position.
4. Release the neutral position safety function.

Place the forward/backward lever on neutral position after checking. Then the function is released and engine returns to normal condition. The engine will start when the starting key switch is turned to starting position.

■ Alarm buzzer on no applying of parking brake check

■ checking steps

1. Place the truck on a flat and solid ground and apply parking brake.
2. Place the forward/backward operation lever on neutral position and lower the fork to the ground. Tilt the mast forward until the fork contact with ground.
3. Shut off the engine and draw out the key switch. Release the parking brake and go away from the seat.

4.3 Check after operation and report

Check after operation and report everyday are important things which is helpful for next day's operating preparation. Before clean and store the truck after operation, check the following points and report to the manager.

1. Check if the engine oil and electrolyte leaks.
2. Check if there are cracked, damaged or loose parts.
3. Lubricate parts if necessary.
4. Check the abnormal parts found during operation.

4.4 Simple maintenance

4.4.1 Lubricating grease and fuel

4.4.1.1 Notes

When lubricating according to STARTING CHECK and CHECK AFTER OPERATION, please understand the following notes.



CAUTION

- Do not check the pipeline or hose with hand directly when checking if there is leakage because the pressure may be applied and danger may be caused.
- If your skin or eye is harmed by high pressure oil, wash with clean water at once and go to see a doctor.
- Please let the EKKO dealer to carry out the visual checking items except the leakage.

• Engine oil, hydraulic oil, transmission oil and gear oil that used under bad condition (high temperature and high pressure will go bad as time pass by. Change the oil regularly referring to OIL AND GREASE and LUBRICATING CHART.



- Change the oil in regulated time even if it does not go bad.
- Be sure to use EKKO specified engine oil. Oil listed in the OIL TYPE TABLE if filled in the truck before delivery.
- Do not use oil mixing with different degrees and numbers.
- Most fault may be caused if foreign matter goes into oil or grease. Take care not to let foreign matters fall into oil or grease during storing and lubricating.
- Add oil with proper quantity because fault may be caused because of insufficient oil or too much oil.
- If the hydraulic oil becomes turbid or there is a possibility of air or water going into oil, fault may be caused if measures are not taken. In that case, please contact your EKKO dealer or agent.
- When changing oil, change the corresponding filter. Please contact your EKKO dealer or agent for oil and filter changing.

■ Fuel



Only an EKKO specified fuel is allowed to be used or the cleanness of exhaust air can not meet the standard requirement. For your health and environment, use EKKO specified fuel.

■ Coolant

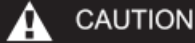

- The coolant temperature is very high when the engine is stopped and there is high pressure inside the radiator. Do not remove the radiator's cap in this case or serious burn may be caused. Rotate the cap slowly before remove it so as to release the pressure when the coolant temperature is lowered.
- Please use new EKKO special coolant. It is prohibited to add hard water such as tap water, mineral water, river water, well water to the cooling system avoiding radiator corrosion or scale forming which will reduce radiator performance and service life.
 - The coolant filled in the truck can not only protect the truck against freezing above -35°C , but also protect the cooling system from corrosion, scale-forming and increase the coolant boiling point remarkable.
 - Change the coolant once a year. If the coolant is bad in less than one year, change it when necessary. When changing the coolant, clean the interior of the cooling system. The freezing point of the coolant should be at least 10°C lower than the lowest environment temperature.
- - Lubricating grease
 - The lubricating grease is used to prevent the connecting parts from lock, rust and producing noise.
 - Only recommended lubricating grease is to be used and lubricate the parts according the interval. For lubricating grease type, refer to the LUBRICATING CHART.
 - Clean the lubricating grease pressed out after lubricating. Clean the lubricating grease from the parts adhered with sand and dirt.

■ Filter

Filter is a very important part which prevents the impurity in oil and hydraulic oil circuit from getting into the machine. Change the filter regularly. Please contact EKKO dealer or agent.

Filter changing note no matter it is carried out by yourself or EKKO dealer or agent:

- Do not use the filter (drum type) again after cleaning.
 - When changing the filter, check if there is metal powder adhered on the filter. If there are powder, find out the reason and take proper measures.
 - Before assembly, do not open the new filter's package too early .

NOTE:

Only EKKO pure filter is to be used.

- Filter with poor quality may affect truck performance and durability. Quality assurance is invalid.

4.4.1.2 Lubricating chart

Oil and grease adding chart (oil and grease adding position and maintenance interval).

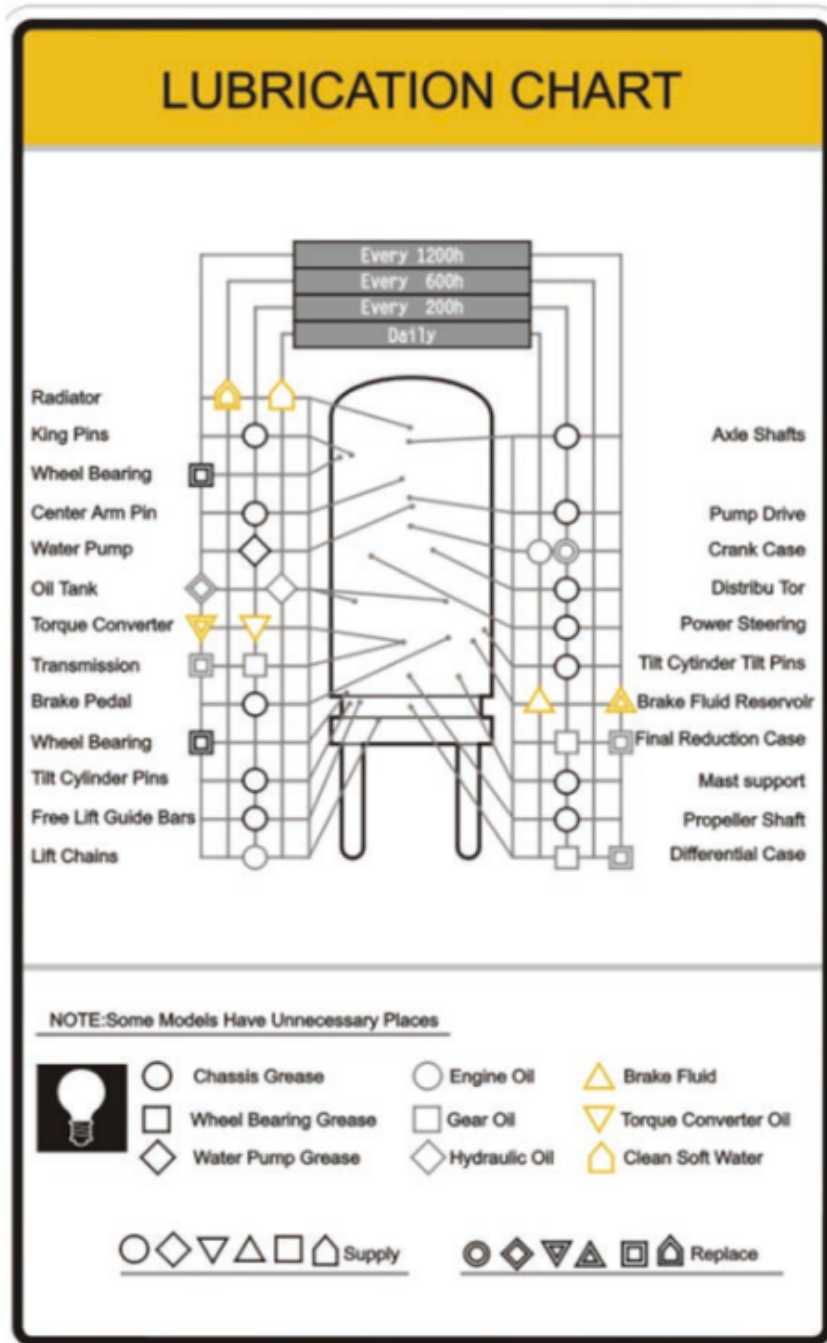

■ Oil type table

Type		Oil number, oil code and applying temperatur			
Engine oil(SM)(refer to note)	Viscosity degree	5W/30	10W/30	15W/40	20W/50
	Applying temperature (°C)	-30 ~ +30	-25 ~ +30	-20 ~ +40	-15 ~ +50
Hydraulic oil	HLW-40				
	Normal temperature: Mobil DTE 10 Excel 25 Shell Tellus S2 V 46	Low temperature: Mobil DTE Excel 46 Shell Donax TC 10W			
Hydraulic-powered transmission oil	HLT-9(Dedicated for HELI)				
	Mobil ATF 220				
Lubricating grease	3# general lithium grease				
Heavy duty tuck gear oil	Mobil Fluid 424				
Anti-freezing liquid	Code	FD-1	FD-2	FD-2A	FD-3
	Applying temperature(°C)	≥ -25	≥ -35	≥ -45	≥ -50

Note: Please refer to ENGINE MAINTENANCE MANUAL for gasoline number and applying temperature. Use gasoline and engine oil meeting relative quality standard. Please refer to ENGINE MANUAL for quality standard or consult with EKKO dealer/ agent.

Oil level table(L)

Parts capacity Model	Hydraulic transmission (torque converter included)	Transmission box	Hydraulic oil tank (full free 3-stage mast)	Axle oil	Radiator
4-5t	8	15	80	13	9

Important

- Use EKKO specialized lubricating grease.

4.4.2 Filter element cleaning

CAUTION

- When the engine is working, serious injury may be caused by fan or belt. Shut off the engine before disassemble or clean filter element.
- When cleaning filter element, dust on it may get into eye or be breathed inside. Wear protection glass, dust-proof cover and other protection devices. Clean it where has no people around.

1. Disassemble clamps (three positions) on air cleaner and disassemble the filter element.

2. Knock the filter element gently avoiding damage the sealing surface or clean the element with compressed air (no more than 0.68MPa) carefully from inside to the outside.

3. Check the filter element visually after cleaning. If there is any damage or dirt still, change the filter element.

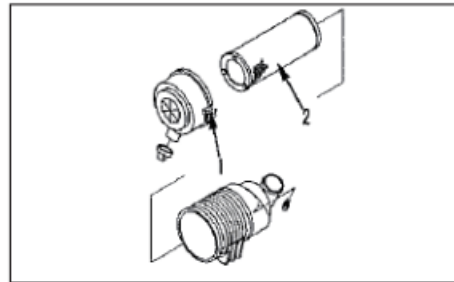

IMPORTANT

Dust may enter into the engine and may be damaged when checking, cleaning or maintaining the filter element with engine running.

Carry out the maintenance work after shutting off the engine.

4.4.3 Vaporizer check and tar remove

Vaporizer is used to adjust LPG pressure and supply heat for fully vaporization when the truck is powered by LPG. During this process, a thick layer of tar will be produced and accumulated in vaporizer. If there is too much tar, it will badly affect engine idling performance.

Warning

- Make sure releasing valve on the LPG cylinder is turned off. If it is not turned off fully, when removing plug, an accidental injury may be caused because of the pressure in the fuel supplying pipe.
- Be sure to wear safety glass and gloves.
- Do not use open fire or smoke in working area.

1. Preheat the engine fully for 5 minutes in idling state.
2. When engine is running, turn off the exhausting valve fully on LPG cylinder and make the engine stop naturally.
Note: The engine will stop when the remaining LPG in the pipe is used up.

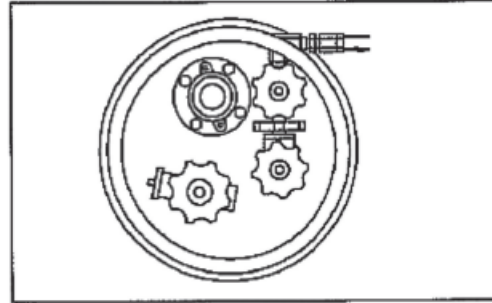

3. Turn the key switch to the OFF position when the engine is stopped.

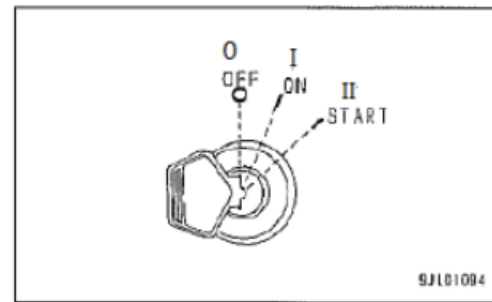

4. Put a piece of cloth under vaporizer and connect the tar.
5. Remove the plug at the bottom of the vaporizer.

6. After the tar is removed, insert the plug.
Important: remove the tar at least once a month.

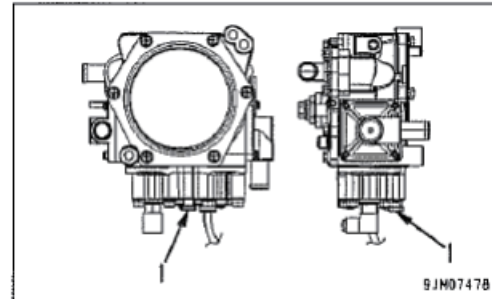

4.4.4 Tyre changing

 **CAUTION**

- Be care not to be pressed by jack when it slips away. when using jack, ensure the supporting position is firm. Do not crawl under the lifted truck.

1. Unload the goods on truck and park the truck on flat and solid ground. Apply parking brake.

2. Place blocks under the tyres needed to be replaced.

3. Lift the truck at the required position.

- (1) Replace the front tyre: (A) under the outer mast
- (2) Replace the rear tyre: (B) under the counter weight

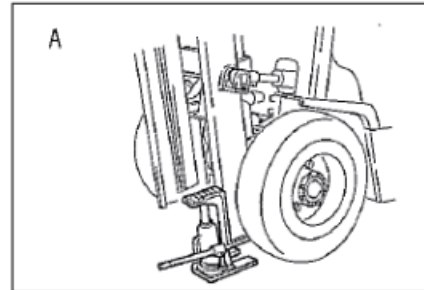

4. Lift the truck to the position where the tyre connects with the ground a little and place a support under the frame. When replacing front tyre, place a support under the forepart and when replacing rear tyre, place one under the rear part.

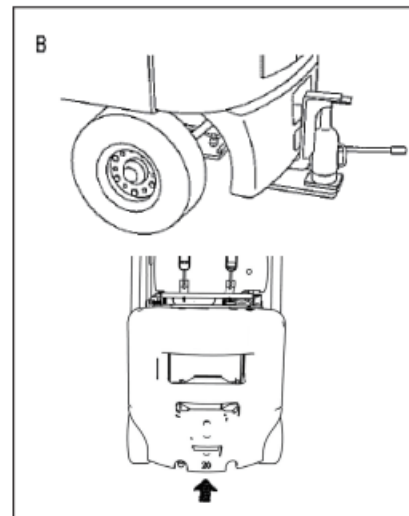

5. Disassembling the tyre



(1) Front wheel: Loose the hub nut with hub nut wrench or other tools until it can be rotate by hand; rear wheel: remove the hub cover and cotter pin and then loose the hub nut with socket until it can be rotate by hand.

(2) Lift the truck with jack to the position where the tyre leaves the ground a little. disassemble the hub nut and tyre.

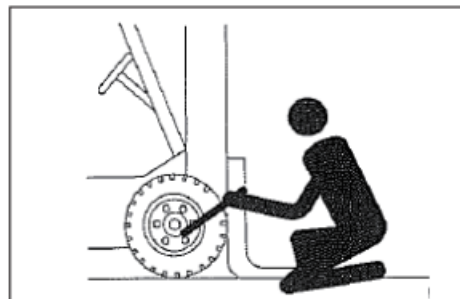

6. Install a new tyre to the hub. For the front wheel, rotate the nut one by one, then tighten the nut diagonally; for the rear wheel, fix the bearing inner ring to the steering knuckle (2), then fix the bearing outer ring and oil seal to the hub successively. Then join the rear wheel assembly and hub. At last, fix bearing outer ring, inner ring, washer, nut, cotter pin and hub cover successively.
 7. Move the support away from the frame. Lower the jack and tighten the hub nut to regulated torque. For standard torque value, refer to REPAIR PARAMETER.
 8. After changing, carry out a test run to check if the hub nuts are loose. If necessary, tighten it.
-

4.4.5 Parking brake shank operation force adjusting



- Wedge the front and rear tyre before adjusting.

1. Press the button (1) and release the parking brake (2) to position B.
2. Adjust the nut (3) until the operation force of the parking brake is reached.

The operation force is 250Nm before delivery. The output brake force may be reduced because of the wear of brake and clearance adjusting mechanism.

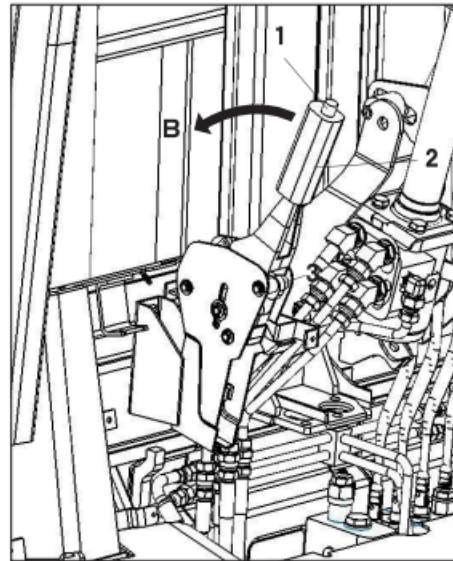

4.4.6 Fuse changing

Fuse may be broken if lights or indicators or the controlling system do not work. Check if the fuses protecting each devices and systems are burn.

CAUTION

- Before changing the fuse, turn off the power. (turn the starting switch to OFF position)
- Change the fuse with the same standard and capability.
- If the replaced fuse is burn again, it may be caused by the abnormal electric system. please contact with HELI dealer or agent.

1. Switch the starting key switch to OFF position.
2. Open the engine hood, fuses are in the electric cabinet n the left side of the truck.
3. Disassemble the fuse box cover and puller inside the fuse box.
4. Clamp the fuse with puller and remove it. Check if it is broken visually.
5. If fuse is broken, change it with the same standard and capability.

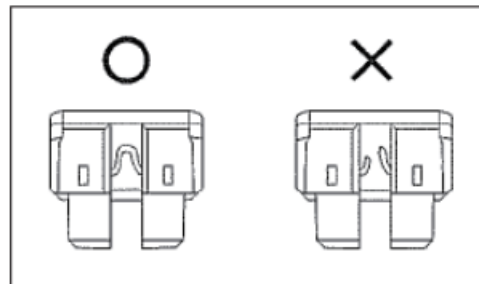

- Electric cabinet
Refer to the following table for fuse capability and corresponding electric parts.

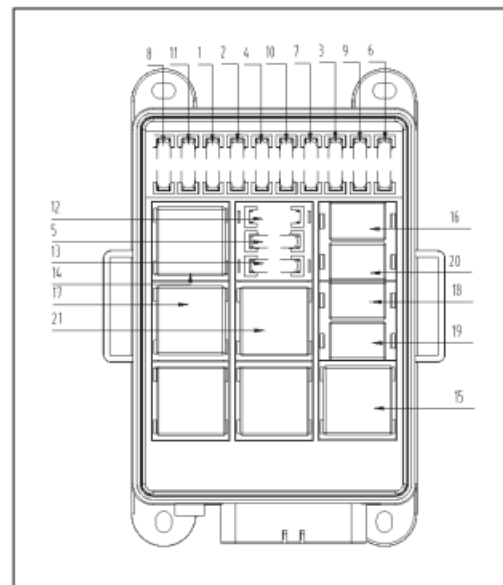

Number	Capability	Color	Corresponding electric parts	Note
1	7.5A	Brown	Meter	
2	7.5A	Brown	Steering light	
3	7.5A	Brown	Horn	
4	7.5A	Brown	Shutting off valve	
5	7.5A	Brown	Commutator	
6	7.5A	Brown	Lifting valve	
7	10A	Red	Width lamp, brake lamp	
8	10A	Red	Reversing light	
9	10A	Red	Spare	
10	15A	Blue	Cab power	
11	15A	Blue	Controller	
12	20A	Yellow	Front lamp	
13	30A	Green	Starting	

Refer to the following table for relay capability and corresponding electric parts.

Number	Capability	Corresponding electric parts	Note
14	70A	Power relay	
15	40A	Light relay	
16	20A	Shutting off vave	
17	70A	Starting relay	
18	20A	Forward relay	
19	20A	Backward relay	
20	20A	Lifting /tilting relay	

Controller

The controller has OPS function.

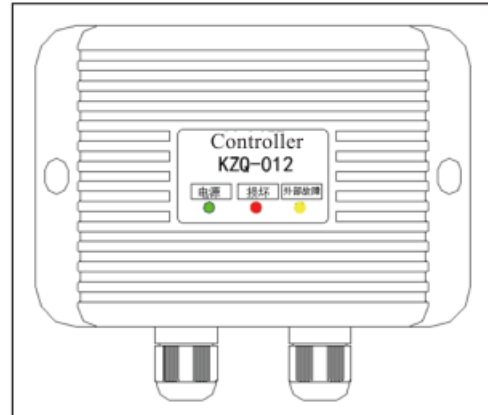

- OPS (driving function)

If the condition that the seat switch is open or driver goes away from the seat or sits on the seat with improper posture is detected by controller for 5s, the controller will disconnect the power of transmission commutator and thus driving power will be disconnected. The locking condition will be released when seat switch is closed and direction switch is placed on neutral position.

- OPS (Loading function)

If the condition that the seat switch is open or driver goes away from the seat or sits on the seat with improper posture is detected by controller for 5s, the controller will disconnect the power of solenoid valve of the control valve and thus lifting and lowering operation will be locked.

- Alarm function

If the condition that the seat switch is open is detected by the controller for 1s, meter buzzer will alarm and the alarm indicator will light on. if the direction switch is not returned to neutral position and the seat switch is open, the buzzer will alarm continually to remind the operator that the OPS is on starting condition.

3 indicators are fixed on the controller so as to know the working condition of the controller. They are power indicator, outer fault indicator and controller fault indicator. If the green power indicator lights on, it means the controller has electricity; if the yellow outer fault lights on, it means the external of the controller has fault; if the red controller fault indicator lights on, it means the controller itself has fault and has to be changed.

4.4.7 Bulbs changing

If the bulb does not light on, the bulb itself may be broken except the fault of fuse. Change the bulb after checking if the fuse is broken.



CAUTION

- Change the bulb with the same standard.
- If the bulb still does not light on, it may be caused by abnormal system. Please contact with EKKO dealer or agent.

1. Switch the starting key and light switch to the OFF position.
2. Remove the glass cover and change the bulb.

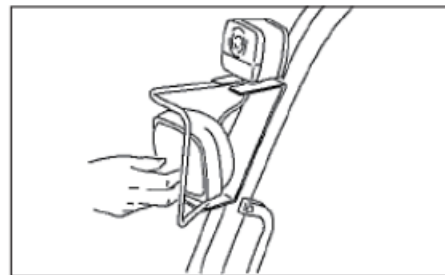

Light power
Front lamp: 12.5W(12V)

4.5 Steps of dealing with the fault battery

If a battery has fault, start the truck with jumper cable to use other truck's battery.

- Notes when disconnecting and connecting jumper cable

CAUTION

- Never connect the positive(+) and negative (-) terminal when connecting the jumper cable.
- Wear safety glass and rubber glove when starting engine with jumper cable.
- Take care not to let the fault truck contact with the normal one when starting the engine with other truck. Hydrogen which is flammable is produced by battery is easy to be lighted by small spark around battery.
- Turn the starting key switch on two trucks to OFF position when connecting jumper cable or truck may move suddenly after the power is connected.
- Connect the jumper cable correctly. Connect the positive cable first when connecting while disconnecting, disconnect the negative cable first. When connecting, connect the last cable to the engine block of the fault truck which produces spark. Keep the connecting point away from the battery.
- When disconnecting cable, never make the clamp connect with the other clamp or the truck.
- The two truck must have the same voltage.

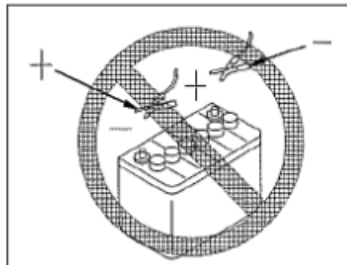

- Jumper cable connecting

Turn the starting key switch on both truck to OFF position and place the forward/backward lever on neutral position. Check if the parking brake is applied. Connect the cables referring to the figure.

- (1) Connect the clamp of jumper cable A to the positive terminal of the fault truck;
- (2) Connect the other clamp of jumper cable A to the positive terminal of the normal truck;
- (3) Connect the clamp of jumper cable B to the negative terminal of the normal truck;
- (4) Connect the other clamp of jumper cable B to the engine block of the fault truck.

IMPORTANT

- Use proper connecting jumper cable and clamp with proper size according to the battery size.
- Two trucks must have batteries with same capacity.
- Make sure the clamps and cables are not damaged or corroded.
- Connect the clamps to terminals or blocks correctly and firmly.

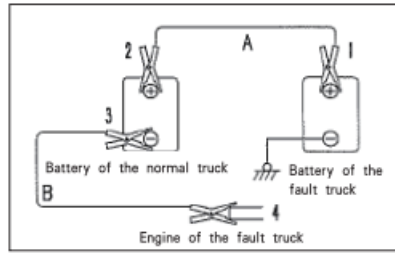

■ Engine starting



Check if the forward/backward operation levers of two trucks are placed on neutral position and if parking brakes are applied.

1. Make sure clamps are connected to battery terminal firmly.
 2. Start the normal truck's engine and make it run at highest speed.
 3. Turn the starting key switch on the fault truck to the STARTING position to start the engine.
- If the engine is not started, start it again 2 minutes later or after a longer time.

■ Cable disconnecting

After the engine is started, disconnect the cable according to the opposite order.

1. Disconnect the other clamp of jumper cable B from the engine block of the fault truck.
2. Disconnect the clamp of jumper cable B from the negative terminal of the normal truck;
3. Disconnect the other clamp of jumper cable A from the positive terminal of the normal truck;
4. Disconnect the clamp of jumper cable A from the positive terminal of the fault truck;

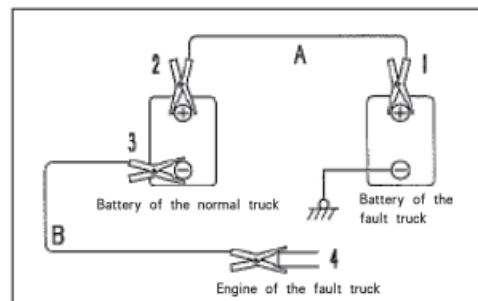

4.6 Working in cold weather

■ Notes when the temperature is low

It is hard to start the engine when the temperature is low. What is more, the coolant may be frozen. Do as the following:

■ Fuel, lubricating oil and hydraulic oil

Use fuel, lubricating oil and hydraulic oil with low viscosity.
For regulated viscosity, refer to OIL TYPE TABLE.

■ Coolant



CAUTION

- Coolant is poison and take care not to get in touch with your skin. If so, wash with lots of clean water and see a doctor.
- Contact professional company or EKKO dealer or agent to deal with the drained coolant. Never pour it onto ground or drainage ditch because it is poison.

IMPORTANT:

Use EKKO specified coolant.

When delivery, coolant suits for the -35°C environment temperature is filled.

Notes when adding or changing coolant:

- Check if radiator, water pump and pipes leak.
- Drain out the coolant and clean the interior of the system before adding coolant.

■ Battery

 CAUTION

- Battery will produce flammable gas and keep it away from open flame.
- Electrolyte is poison and take care not to get in touch with your skin. If so, wash with lots of clean water and see a doctor.
- Never pour electrolyte onto ground or drainage ditch because it is poison.
- If electrolyte gets in touch with the truck, clean it with clean water.
- If battery freezes, do not charge it or start the engine with other power, or the battery may explode.
- Battery performance will be badly affected under low temperature environment and thus engine will be hard to start. Battery with insufficient charging will freeze. So charge the battery fully for next day's start.
- Battery performance will be badly affected under low temperature environment so disassemble it from the truck to keep it in a warm place and assemble it the next day. (Especially when the temperature is low or the truck will not use for a long time.)

■ Note after working

Drain out the water in fuel pipeline in preventing of freezing.

Please refer to the WATER AND GAS EXHAUSTING OF THE WATER-OIL SEPERATOR for oil-water separator water draining of the diesel engine.

■ When the cold weather is over

Do the following as the weather gets warm.

- According to the OIL TYPE TABLE, change the fuel and engine oil to regulated viscosity.

4.7 Measures for engine over heating

■ Measures for engine overheating

 CAUTION

There is a danger of scalding caused by the ejecting of steam or boiling water if the radiator cap is removed at once. Remove the radiator cap slowly after the cooling liquid is cool.

Take the following measures when the coolant temperature gauge points to the red range:

1. Park the truck in a safe area.
2. Keep the engine idling and open the engine hood for good ventilation.
Shut off the engine at once if cooling fan does not work.
3. Shut off the engine hen the coolant temperature gauge points to the white range:
4. Check the following items when the engine is cool:
 - coolant level
 - check if fan belt is cut or loose;
 - engine oil level
 - check if the radiator is blocked;
5. If the coolant or engine oil level is low. add to proper level.

If the fault reasons, contact a manager and stop use of the truck. Then contact your EKKO dealer or agent.

- Clean the interior of the cooling system.
- If waterlogging or rust is produced in the cooling system, it means the cooling system efficiency is poor and it causes overheating.

- Please contact with EKKO dealer or agent for maintenance because the cooling systems needs periodical checking and cleaning with radiator washing solution.
 - Cleaning of the radiator

 **CAUTION**

- Wear glasses in preventing of foreign matters getting into eye.
 - Never make the compressed air, steam or water flow point to people or serious injury may be caused.
- Engine overheat may be caused if radiator is blocked, clean it with gas flow, steam or water flow. Set the gas flow or steam to the regulated pressure and adjust the nozzle to proper angle:
Gas pressure: lower than 0.98MPa (10kgt/cm²)
Water pressure: lower than 0.49MPa (5kgt/cm²)

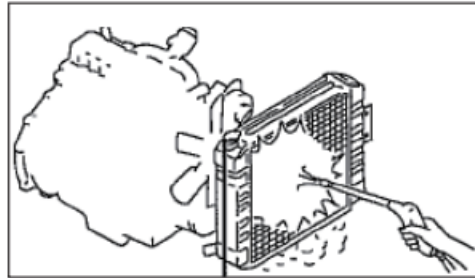

- Check the fan belt tension
If the belt is loose, adjust it to regulated tension.

4.8 Operate truck in special environment or with force

The truck is designed and tested for normal working condition and environment. If it is used under special environment and condition, truck will be badly affected such as aging, life time reducing, parts harm even maintenance free parts.

If the truck has to be operated under special environment, the truck needs special maintenance and measures to bear the harsh working condition or environment. For detail, please contact your EKKO dealer or agent.

- Examples when using the truck in special environment or with force
 - Truck travel on road with saline water, chemicals (acidity or alkalinity) or solution directly or contact with such environment indirectly through driver's hand or feet;
 - Environment full with erosive gas;
 - Blow by salty sea wind;
 - Environment with dew or often soaked by water.
 - Dusty environment;
 - Other applications other than the design purpose;
 - Specialized or special working for a long time;
 - Applications prohibited in this manual;
 - Others.

IMPORTANT:

EKKO will not bear responsibility if the truck is used under the special environment or with force.

- Technology may not involve in certain condition.
- The truck can not be used where has a danger of explosive.

4.9 Measures if the fork can not be lowered



CAUTION

- Stop working at once if the fork can not be lowered during operation. Never use the truck before repair.
- Place signs such as NO ENTERING or NO USING on the truck in preventing of people going under the lifted fork.
- Do not touch mast, fork, chain or other working devices or truck may move accidently and serious accident may be caused.

Contact your EKKO dealer or agent for repairing coordination.

1. Stop working at once if the fork can not be lowered during operation.
2. Park the fault on a flat ground away from the emergency exit and fire extinguisher. For parking, refer to STOPPING AND PARKING and STOPPING AND PARKING FOR A TIME.
3. If the loaded fork can not be lowered during operation, check if there is a danger of goods falling. Make sure there is a wide area marking NO ENTERING or park the truck facing the wall.

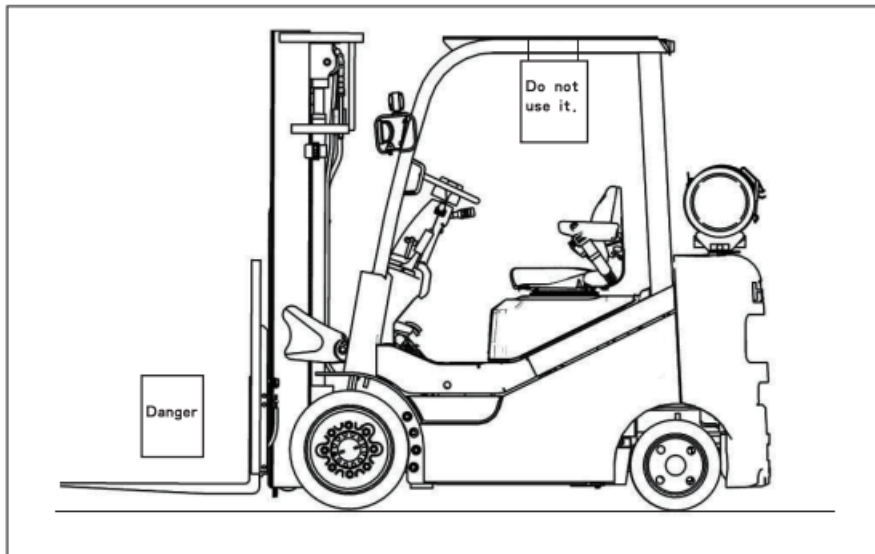

4.10 Truck cleaning

⚠ CAUTION

There is a danger of truck being out of work or mis-moving if water entering into electric system (controller, sensor, contactor and so on). Do not clean the electric system with water or air with high pressure.

Cleaning steps

1. Turn the starting key switch to the OFF position and draw out the key.
2. Clean the parts (1~4) shown in the figure and follow the notes described in the table.
3. Dry the cleaning parts.
4. Insert the key and turn it to ON position after the cleaning parts are dry completely. Check if there is any abnormal and then begin to operate.

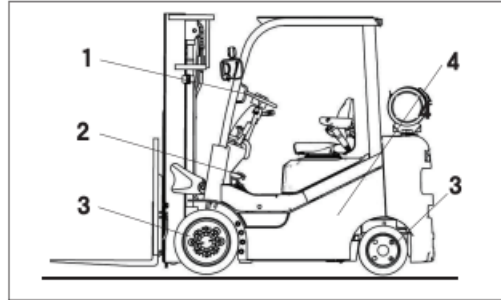

No.	Cleaning parts	Cleaning method
1	Cabinet surface	Clean it with water from pipeline
2	Front floor board	NOTE: when cleaning, reduce the water flow so as to reduce the water pressure as shown in the figure below. (for part 1 and part 2)
3	Front and rear tyres Front and rear axle	Clean with air or water with high pressure from pipeline
4	External parts except the parts above	Clean with air or water with high pressure from pipeline
Other notes		1. Do not clean the interior of the meter; 2. Cover the engine, transmission box and their electric devices such as electric wire, contactor and fuses and so on with water proof cloth when cleaning engine hood and parts under the floor board with high pressure air and water.

4.11 Storing for a long time

Stick to the following points when storing the truck for long time (more than one month).

■ Before storing

Before storing the truck, carry out the following maintenance after cleaning the parts. If the truck has to be kept outside, park the truck on a flat ground and cover it with canvas.

- Add the fuel tank fully so as to prevent water from depositing.
- Apply lubricating grease and change the engine oil.
- Apply lubricating grease to the exposed part of the hydraulic cylinder piston rod.
- Disconnect the battery negative terminal and cover it or disassemble it from the truck and store it inside.

● Use EKKO specified coolant to avoid freezing.

- Operate or drive the truck once a month so as to ensure the lubricating parts are protect by oil film completely during storing.
- Clean the lubricating grease on hydraulic piston rod when operating working devices.
- Charge the battery once a month because the battery will discharge even it does not work.
- When the truck has to be stored for a long time, turn off the all LPG valves. Make sure the remained fuel in the pipe is used up. Store the truck in a well ventilated and cool place.

■ After storing

Carry out the following maintenance before operation after storing.

- Clean the lubricating grease on hydraulic piston rod.
- Apply lubricating grease and engine oil where necessary.
- Check the engine oil before and after engine starting. If the engine oil is mixed with moisture, change the engine oil.

IMPORTANT

Please contact your EKKO dealer or agent before operation when using the truck without anti-rust maintenance once a month.

4.12 slinging the truck

CAUTION

- Put the sling into the specified holes on top of the overhead guard and counter weight.
- Never sling the truck at the over head guard and cab base (if cab is assembled), or there is a danger of falling down.
- Put the sling into the specified holes on top of the overhead guard and counter weight after ensuring the mast and counter weight are assembled firmly.
- Any person is not allowed to stay under or near the truck.

1. The slinging positions are the top part of the over head guard and the holes of the counter weight.

2. Check if the mast and counter weight are assembled firmly.

Tighten the counter weight bolts to regulated torque.

Tighten the mast lower part fixing bolts to regulated torque.

Please refer to 4.16 REPAIR PARAMETER for torque value.

3. Use undamaged sling and steel rope with enough strength.

4. When slinging the truck, be care not to let the over head guard or cab contact with steel rope and so on. Adjust the steel rope to proper length so as to avoid truck tilting. Do not hit the truck when slinging.

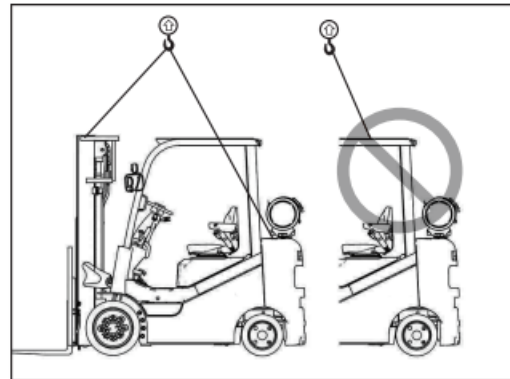

4.13 Loading and unloading the truck



CAUTION

There is a danger of tipping over and falling when loading or unloading the forklift truck. So follow the rules below:

- Park the trailer on a flat road. Apply parking brake and wedge the wheels.
- Use connection board with proper length, width and strength.
- Operate the truck with proper posture.
- If the truck is operated with such posture (the seat does not bear your whole weight, for example stand or lean against forward, backward or side when operating), the OPS will act and engine power transmission will be cut. In that case, the truck will slide down even acceleration pedal is pressed or the truck is going uphill. If necessary, assign a towerman, so that the driver is not necessary to stand or lean forward or side to observe around. Please refer to the OPS (driving function) for detail.
- Place the board to form a gentle slope when using it. Align the center of the forklift truck and trailer's and lock firmly avoiding displacement.
- Do not change the direction when travelling on a board. If necessary, place the board again according to the needed direction and travel again.

1. Use a trailer with enough capacity according to forklift truck weight and size.
2. Park the trailer on a flat ground. Apply the parking brake and wedge the wheels.
3. Connect the loading platform and ground with connection board and make sure it will not disconnect.
4. Do not move the trailer before loading is finished.
5. Operate the truck slowly with proper posture when loading or unloading the truck.
6. Wedge the wheels of the truck and fix the truck with steel rope or chain in order to prevent the truck from moving during transportation.

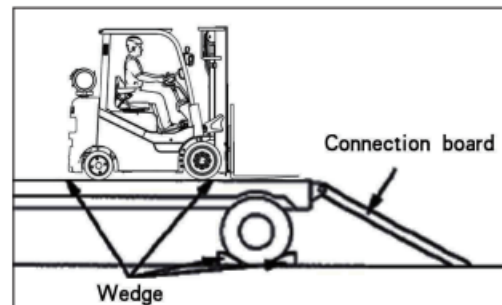

4.14 Check and maintenance time table

- Please contact your EKKO dealer or agent for checking and maintenance items not described in the manual.
- A serious accident may be caused, or truck service life may be affected if the truck is not checked or maintained improperly. For safety reasons, please contact your EKKO dealer or agent for check, maintenance, and repair.
 - Check and maintenance time table
- Check and maintain the truck as recommended by EKKO.
- Table 1-9 are EKKO internal combustion forklift truck maintenance time table based on standard working time and condition (8 hours for one day, 200 hours for one month). If the truck works under harsh condition, maintain ahead of schedule.

○ refers to check, maintain and replenish. ● refers to

change. Please refer to gasoline truck maintenance for LPG truck maintaining.

Table 4-1 Engine maintenance time table

Item	Checks	Tool	Check and maintenance interval				
			Daily (8 hrs)	Monthly (200hrs)	Quarterly (600hrs)	Semiannually (1200hrs)	Annually (2400hrs)
Engine	Engine working condition by visual check		○				
	Engine sound		○				
	Exhausting gas color		○				
	Clean or change filter element			○	●		
	Cleanness of crankcase				○		
	Clearance of adjusting valve	Thick plug gauge				○	
	Tighten cylinder head bolt	Torque wrench		○ (gasoline engine, first time)		○	
	Cylinder compression pressure	Pressure gauge					○
Crankshaft ventilation	Check if valve and pipeline are blocked or damaged.				○		
Speed controller or injection pump	Check the max. rotation speed without load	Speedometer				○	
Lubricating system	If engine leaks		○				
	Check the oil level and cleanness		○				
	Change engine oil			● (5liters for the first time, every 200hrs in the future)			
	Change engine oil filter element			● (5liters for the first time, every 200hrs in the future)			

Item	Checks	Tool	Check and maintenance interval				
			Daily (8 hrs)	Monthly (200hrs)	Quarterly (600hrs)	Semiannually (1200hrs)	Annually (2400hrs)
LPG system	Check the LPG tank and its connector		○	○	○	○	○
	Check the LPG hose and its connector		○	○	○	○	○
Cooling system	Coolant level		○				
	Leakage condition		○				
	Pipeline ageing condition				○		
	Performance and mounting condition of the radiator cap			○			
	Clean or change the coolant					●	
	Check the tension of fan belt and condition		○				



Table 4-2 Transmission system maintenance time table

Item	Checks	Tool	Check and maintenance interval				
			Daily (8 hrs)	Monthly (200hrs)	Quarterly (600hrs)	Semiannually (1200hrs)	Annually (2400hrs)
Hydraulic- powered transmission box	Leakage condition		○				
	Check the oil level or change the oil			○		●	
	Gear shifting lever operation condition and check if it is loose.			○			
	Performance of controlling valve and hydraulic-powered clutch		○				
	Inching valve performance		○				
	Spare travel of inching pedal and its working condition		○				
	Change filter element					●	
Front axle	Leakage check		○				
	Change the oil					●	
	Check if the fixing bolts are loose.			○			

Table 4-3 Wheel maintenance time table

Item	Checks	Tool	Check and maintenance interval				
			Daily (8 hrs)	Monthly (200hrs)	Quarterly (600hrs)	Semiannually (1200hrs)	Annually (2400hrs)
Tyre	Crack or damage		○				
	Wear condition	Depth meter		○			
	Abnormal wear condition		○				
	Check if there are any foreign matters on the tyre such as nail.			○			
Tyre mounting	Check if the bolts are loose.	Test hammer	○				
	Check if there is any damage.		○				
Rim and spoke	Check if the rim, spoke and plate wheel have any damage.		○				
Wheel bearing	Check if there is any loose and noise.			○			
	Clean and apply the lubricating grease again.					●	
Axle	Check if the axle body is deformed, has any crack or damages.			○			

Table 4-4 Steering system maintenance time table

Item	Checks	Tool	Check and maintenance interval				
			Daily (8 hrs)	Monthly (200hrs)	Quarterly (600hrs)	Semiannually (1200hrs)	Annually (2400hrs)
Steering wheel	Clearance check		○				
	Check if there is any loose in axial direction.		○				
	Check if there is any loose in radial direction.		○				
	Check the operation condition.		○				
Steering unit	Check if the fixing bolt is loose.			○			
Knuckle of the rear axle	Check if the king pin is loose or damaged.	Test hammer		○			
	Check if there is any curve, deformation, crack or damage condition.			○			
	Check the mounting condition.			○			
Steering cylinder	Check the operation condition.		○				
	Check if there is any leakage.		○				
	Check if there is any loose when mounting and Hinged.			○			

Table 4-5 Braking system maintenance time table

Item	Checks	Tool	Check and maintenance interval				
			Daily (8 hrs)	Monthly (200hrs)	Quarterly (600hrs)	Semiannually (1200hrs)	Annually (2400hrs)
Brake pedal	Spare travel		○				
	Pedal travel		○				
	Operation condition		○				
Parking brake operation	Check if brake works well and has enough travel.		○				
	Operating performance		○				
Rod, cable and so on	Operating performance			○			
	Check if the connection is loose.			○			
Pipeline	Check if there is any damage, leakage or crack.			○			
	Check the condition of connection and clamp parts.			○			
	Check if there is air in the brake pipeline.		○				
Master cylinder	Leakage condition		○				
	Check the oil level and change it when necessary.		○			●	
	Working condition of master pump						○
	Check master cylinder for leakage or damage.						○
	Check the wear condition of the master pump, piston cup, one-way valve. Change if necessary.						●
Brake floor board	Check if the floor board deforms.						○
	Check if it is crack.	Penetrant test					○
	Check if it is loose when mounting.	Test hammer					○

Table 4-6 Lifting system maintenance time table

Item	Checks	Tool	Check and maintenance interval				
			Daily (8 hrs)	Monthly (200hrs)	Quarterly (600hrs)	Semiannually (1200hrs)	Annually (2400hrs)
Fork	Check forks for damage, deformation and wear condition.		○				
	Check for stopper pin for damage or wear.				○		
	Check fork base and hook welding for defective cracks or damage.			○			
Mast and fork bracket	Check if the welding between the inner mast, outer mast and cross beam has crack and damage.			○			
	Check tilt cylinder bracket and mast for defective weld, cracks or damage.			○			
	Check inner and outer mast for defective weld, cracks or damage.			○			
	Check fork bracket for defective weld, cracks or damage.			○			
	Check roller for looseness			○			
	Check mast support bushings for wear or damage.			○			
	Check mast support cap bolts for looseness.	Test hammer		○ (only the first time)		○	
	Check lift cylinder tai bolts, piston rod head bolts, U-bolts and piston head guide bolts for looseness.	Test hammer		○ (only the first time)		○	
	Check roller, roller axle and welded parts for cracks or damage.			○			
Chain and sheave	Check chains for tension, deformation, damage or rust.		○				
	Chain lubricating			○			
	Check connection of chain anchor pin and chain for looseness.			○			
	Check sheaves for deformation or damage.			○			
	Check sheave bearing for looseness.			○			
Attachments	Check working condition of attachments			○			
Lifting cylinder	Check piston rod, rod screw and rod end for looseness, deformation or damage.	Test hammer	○				
	Operating condition		○				
	Leakage condition		○				
	Check pins and bearings for wear or damage.			○			
Hydraulic pump	Check hydraulic pump for leaks or noise.		○				
	Check pump drive gear for wear.			○			

Item	Checks	Tool	Check and maintenance interval				
			Daily (8 hrs)	Monthly (200hrs)	Quarterly (600hrs)	Semiannually (1200hrs)	Annually (2400hrs)
Hydraulic oil tank	Oil level check and oil change		○				● (1500hrs for the first time, every 2400hrs in the future)
	Clean oil suction filter element					○	
	Remove the foreign matter					○	
Return oil filter	Change the return oil filter				● (300hrs for the first time)	●	
Control lever	Check if the connection is loose		○				
	Operating condition		○				
Control valve	Oil leakage		○				
	Working condition of safety valve and tilting self lock valve			○			
	Safety valve pressure measurement	Oil pressure gauge				○	
Pipeline connectors	Check for oil leakage, looseness, crack, deformation and damage.		○				
	Pipeline change						● 1-2 years
Gasket for hydraulic oil tank cover and fuel tank cover	Change (without disassemble)						2 years
	Change (with disassemble)						Disassemble and change

Table 4-8 Electric system maintenance time table

Item	Checks	Tool	Check and maintenance interval				
			Daily (8 hrs)	Monthly (200hrs)	Quarterly (600hrs)	Semiannually (1200hrs)	Annually (2400hrs)
Ignition device (for gasoline engine)	Check distributor cap for check.				○		
	Check spark plug for burn.						○
	Adjust spark plug clearance				○		
	Clean spark plug				○		
	Check distributor cap high-voltage cord for installation						○
	Check distributor cap for burn						○
	Check distributor center piece for wear or damage						○
	Apply grease on spindle					○	
	Check high voltage wire for damage						○
Starting motor	Engagement of small gears				○		
Battery	Electrolyte level, cleaning				○		
	Proportion of electrolyte				○		
Wire	Wire harness damage and loose condition				○		
	Electric circuit connection condition				○		
Generator	Generator connection condition				○		
	Generator belt loose or damage condition					○	
	Generator electricity generating condition						○
Electric box	Check plug and connector condition				○		
	Check the box and plug and connector anti-water function.				○		

Table 4-9 Safety devices and accessories maintenance time table

Item	Checks	Tool	Check and maintenance interval				
			Daily (8 hrs)	Monthly (200hrs)	Quarterly (600hrs)	Semiannually (1200hrs)	Annually (2400hrs)
Overhead guard and backrest	Check if the mounting is firm	Test hammer	○				
	Check if there is deformation, crack and damage		○				
Steering indicator	Working and mounting condition		○				
Horn	Working and mounting condition		○				
Light	Working and mounting condition		○				
Buck buzzer	Working and mounting condition		○				
Rear view mirror	Check if there is dirt or damage		○				
	Rear view condition		○				
Meter	Meter working condition		○				
Seat	Check if the bolts are damaged or loose			○			
Body	Check if the frame and cross beam are damaged or cracked.				○		
	Check rivet or bolts are loosed.	Test hammer			○		
	If necessary, check the parts that repaired before.		○				
	Overall check				○		
Grease adding and oil change	Check the chassis's lubricating condition after cleaning	Grease gun		○			

4.15 Change the safety key parts regularly

Safety parts listed in the table below should be changed regularly for safety reason.

If the parts exceed their service life, they may be aging and go bad. Their condition is hard to be known through regular maintenance. So no matter how are the parts, change them if their service life is reached. If there is any abnormal before its service life is reached, repair or replace the part at once. If the pipe clamp has any damage such as deformation or crack, change the pipeline along with the clamp.

■ Key parts table

Number	Parts name	Service life
1	Main cylinder, wheel cylinder cup, dust sealing and so on	1
2	Rubber parts of brake booster	1
3	Brake pipeline	2
4	Oil reservoir and pipeline	2
5	Parking brake switch (hydraulic type)	2
6	Fuel pipeline	2
7	Rubber parts inside of the steering system	2
8	Lifting chain	2-4
9	Hydraulic pipeline	2

4.16 Repair parameter

Parts	Checks	Unit	4-5t		
Driving system	Hub nut	Tighten torque	Front tyre	Nm	480–560
			Rear tyre	Nm	130–194
Steering system & braking system	Steering hand wheel	Clearance (when pump is working)	mm	10–15°	
	Inching pedal	Clearance	mm	1–3	
		Inching travel	mm	0	
		The initial height of the front floor board	mm	110	
	Brake pedal	Clearance	mm	0	
		The initial height of the front floor board	mm	110	
Brake	Operation force of the parking brake	N	250		
Overhead guard	Leg fixing bolt	Tighten torque	Nm	90	
	Top connecting bolt	Tighten torque	Nm	90	
Counter weight		Tighten torque	Nm	950	
Front axle fixing bolt		Tighten torque	Nm	530–720	

Optional

Optional item	Optional details
Mast type	Normal
	Full free 3-stage mast
Tyre choice	Electro-hydraulic direction changing
	Black ,No pattern
	Black, pattern
	Environmental protection type, No pattern
Tilting angle	6° -5°
	3° -5°

Optional item	Optional details
Number of throw	Two throw
	Three throw
	Four throw
Overload choice	Overload protection (the third throw)
Air cleaner	Normal air cleaner
	Dry type double air cleaner
	Wet type double air cleaner
Thread	Metric thread
Speed limit choice	Speed limit alarm
Warning light choice	Rotating type warning light
	flickering type warning light
	Rotating buzzer warning light
Seat choice	Grammer full-suspension seat (with safety switch)
	Gaoyou suspension seat(with safety switch)
	Tiancheng semi-suspension seat (with safety switch)
	Tiancheng full-suspension seat (with safety switch)

Optional item	Optional details
Key	Non-universal key
	Universal key
Wind shield and ceiling	Front windshield glass
	Rear windshield glass
	Head rain shield glass
	Iron sheet ceiling
OPS system	OPS (driving function)
	OPS (whole set)
Fire extinguisher	Fire extinguisher
Fan	Fan
Additional choice	Sling
Power switch	Power switch
Rear working light	Rear working light
Protection net	Protection net (before overhead guard)
Plate	Chinese
	English
	French
	German
	Polish
	Finnish
	Persian
	Spanish
	Portuguese
	Slovenija



Operation and Maintenance Manual
EK50LP ;10K Series
Liquid Propane Forklift
with Pattern Cushion Tires.

