

EKKO[®]

MATERIAL HANDLING EQUIPMENT

MOVING **AHEAD**

WALKIE PALLET JACKS

EP20E / EP25E

- 4400-5500 lbs. Capacity
- Forks 27x48"
- AC Vertical Drive Motor
- Internal Charger
- Polyurethane Wheels
- Electromagnetic Braking
- Curtis Instrument Controller
- Batteries and Charger Included



EP20E | EP25E

Superior quality, maneuverable, compact, and durable for all your material handling applications. Ideal for small aisles and areas.

WEIGHT CAPACITY: 4400-5500 lbs.

LIFT HEIGHT: 7.9"

FORK LENGTH: 27x48"

TURNING RADIUS: 60"

EP20E BATTERY | CHARGER: 24/100 V/ah | 24/15 V/A

EP25E BATTERY | CHARGER: 24/210 V/ah | 24/30 V/A

SPEED TRAVEL: 3.3 mph empty; 3.0 mph loaded

LIFTING SPEED: 1.1 IPS empty; .8 IPS loaded

LOWERING SPEED: 1.5 IPS empty; 1.5 IPS loaded

WHEELS: polyurethane

HYDRAULICS LIFTING MOTOR: 24V 800 Watt lifting motor with hardened chrome moly steel for durability.

DRIVE MOTOR: 24V/1300-Watt AC Drive motor for efficiency and high torque.

AC CONTROLLER: 24V CURTIS Instrument provides performance through entire range of speed; Constant travel speed regardless of load; Battery discharge indicator combination gauge.

BRAKES: Electro-magnetic braking for secure stopping power; Electronic neutral braking for accurate control.

OPERATOR CONTROLS: Throttle, lifting, lowering, turtle mode and horn functions are located on the ergonomic handle; turtle button; belly button reverse safety features allow the unit to stop and reverse to avoid collision or injury.

CHASSIS AND MAST: Robotic Welding; Heavy duty steel for durability.



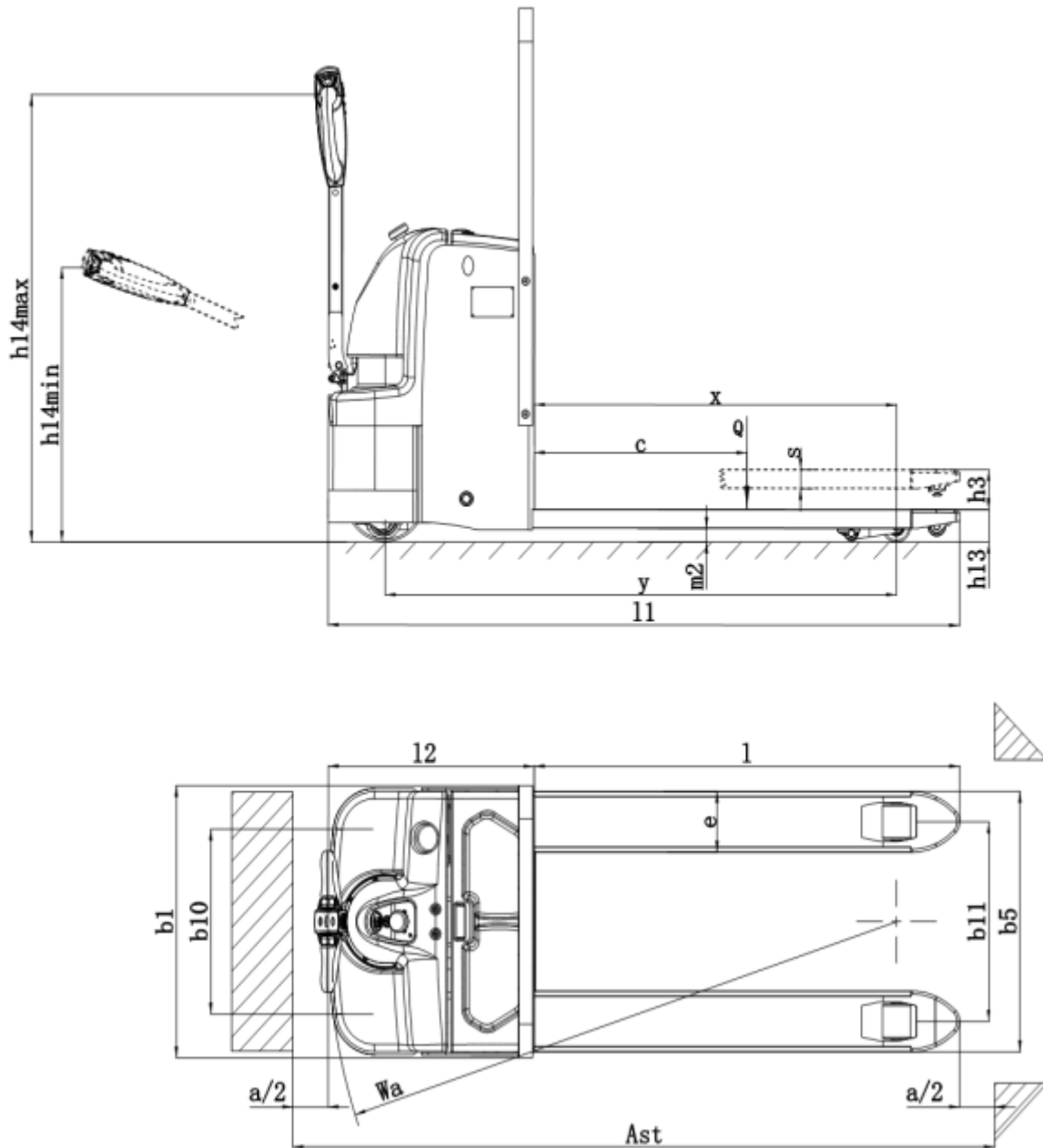

MODEL #	LOAD CAPACITY	FORKS	Lithium BATTERY	SERVICE WEIGHT
EP20E	4400lbs	27x48"	24V/100Ah	952lbs
EP25E	5500lbs	27x48"	24V/210Ah	1108lbs