



**MOVING AHEAD**

# Lithium Walkie Reach Stacker

ER15-138LI / ER15-177LI / ER15-189LI / ER15-216LI

- 3300 lbs. load capacity
- Lift height 138-216"
- Side Shift
- Free Lift
- Reach 19.7"
- EPS
- Center AC Drive Motor
- AC Lift Motor
- 63.4" Turning Radius
- Curtis Controller
- Battery and Charger
- Synchronous Lift Control



# Lithium Walkie Reach

ER15-138LI / ER15-177LI / ER15-189LI / ER15-216LI



Feature				
Brand			Three-Stage Mast	Two-Stage Mast
Model			ER15-177/189/216LI	ER15-138LI
Power Type			Battery	Battery
Operation Mode			Walk-behind	Walk-behind
Rated Load Capacity	Q	LBS	3300	3300
Load Center Distance	C	Inches	24	24
Wheelbase	Y	Inches	55.7	55.7
Tire				
Tire Material, Drive Wheel/Load Wheel			Polyurethane (PU)	Polyurethane (PU)
Number of Drive/Load Wheels (X=Drive Wheel)			1X,2	1X,2
Dimensions				
Fork Angle (Front/Rear)	$\alpha/\beta$	$^{\circ}$	2 $^{\circ}$ /5 $^{\circ}$	2 $^{\circ}$ /5 $^{\circ}$
Overall, Height (Mast Retracted)	h1	inches	82.3/86.2/89	92.9
Free Lift Height		inches	60.2/64.2/66.9	0
Rated Lift Height	h3	inches	177.2/189.0/216.5	137.8
Overall, Height (mast extended)	h4	inches	224.6/236.2/263.5/184.8	184.8
Overall Length	L1	inches	86.6	86.6
Overall Width (Body/Legs)	b1/b2	inches	32.3/48.5	32.3/48.5
Fork Size	s/e/l	inches	1.4x4.0x45.3	1.4x4.0x45.3
Fork Outside Width	b5	inches	32.2	32.2
Inner Width of Legs	b4	inches	48	48
Minimum Ground Clearance	m1	inches	2.1	2.1
Turning Radius	Wa	inches	63.4	63.4
Body Length (Excluding Forks)	L4	inches	65.2	65.2
Performance				
Travel Speed, Loaded/Unloaded		in/s	12.8/13.1	12.8/13.1
Lifting Speed, Loaded/Unloaded		in/s	590/787	590/787
Lowering Speed, Loaded/Unloaded		in/s	1181/1181	1181/1181
Forward Speed, Loaded/Unloaded		in/s	27.6/23.6	27.6/23.6
Maximum Gradient, Loaded/Unloaded		%	15/6	15/6
Drive Brake Type			Electromagnetic Brake (E/M)	Electromagnetic Brake (E/M)
Motor				
Drive Motor Rated Power S2 60 minutes		KW	1.5	1.5
Lift Motor Rated Power S3 15%		KW	4.5	4.5
Battery Voltage/Rated Capacity K5			24V/200Ahn (Lithium)	24V/200Ah (Lithium)
Other				
Drive Control Type			AC Speed Control	AC Speed Control
Synchronous Proportional Lift Control Valve			Yes	Yes

# Lithium Walkie Reach

ER15-138LI / ER15-177LI / ER15-189LI / ER15-216LI

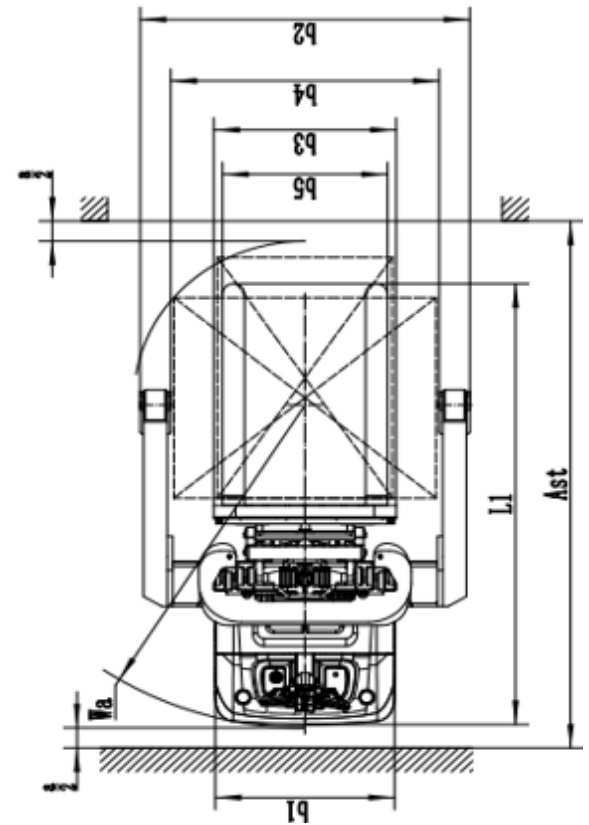
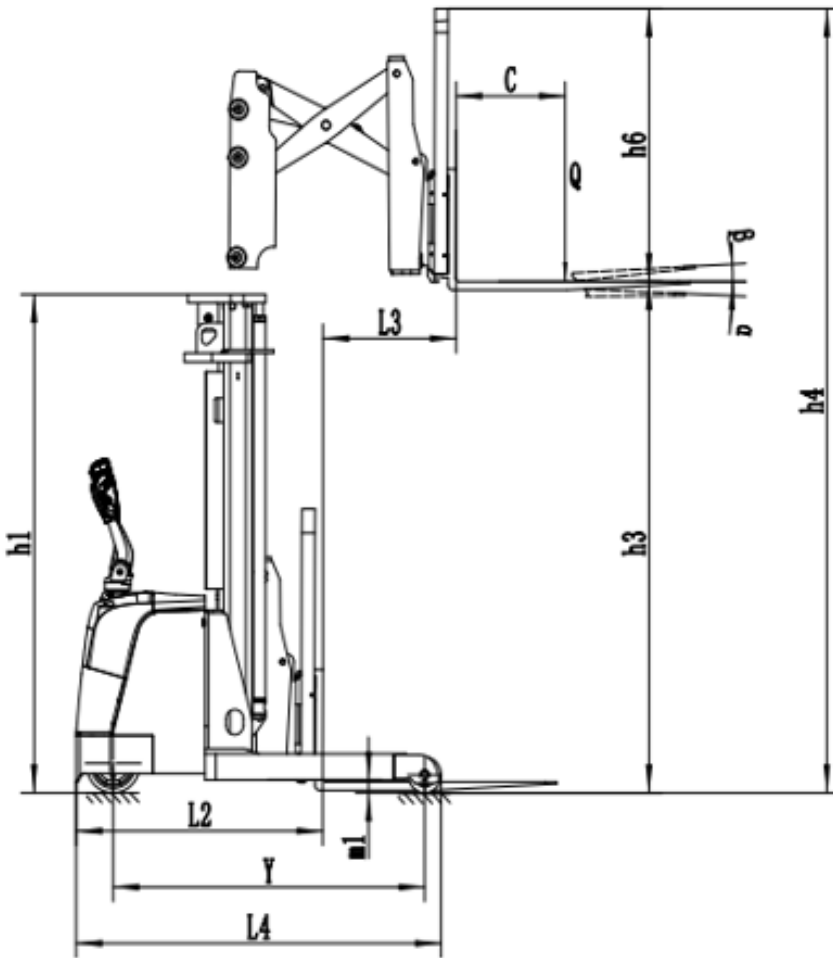

MODEL #	CAPACITY	LIFT HEIGHT	FREE LIFT	SERVICE WEIGHT
ER15-138Li	3,300lbs	138"	NA	3780lbs
ER15-177Li	3,300lbs	177"	60.2	4565lbs
ER15-189Li	3,300lbs	189"	64.2	4590lbs
ER15-216Li	3,300lbs	216"	66.9	4700lbs



1761 W. Holt Ave.  
Pomona, CA 91768 USA

AUTHORIZED DEALERS ONLY  
[www.ekkolifts.com](http://www.ekkolifts.com)

T: (877) 232-6517 F: (909) 222-6861