

EKKO[®]

MATERIAL HANDLING EQUIPMENT

MOVING **AHEAD**

MANUAL PALLET JACKS A25



- 5500 lbs. Capacity
- Forks 27x48
- Compact & Economical
- Polyurethane Wheels
- Robotic Welding
- German Seal System
- 3 Lever Handle
- Ergonomic Handle
- 3 Year Limited
Warranty

A25 SERIES MANUAL PALLET JACK

Superior quality, maneuverable, compact, and durable for all your material handling applications. Ideal for small aisles and areas.

- WEIGHT CAPACITY:** 5500 lbs.
- LIFT HEIGHT:** 7.5"
- FORK LENGTH:** 27x48"
- TURNING RADIUS:** 55"
- DRIVE WHEELS:** (2) 7" x 2" polyurethane
- ENTRY WHEELS:** (2) 1.75" x 1" Nylon
- LOAD WHEELS:** (2) 2.75" x 3.5" polyurethane
- HYDRAULIC PUMP:** German Seal system, Chrome piston rod,
- ERGONOMIC HANDLE:** Three control positions for Lowering, lift and neutral.
- CHASSIS AND MAST:** Robotic Welding; Heavy duty steel for durability.

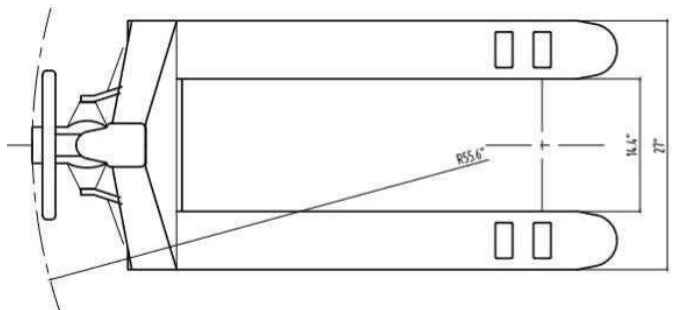
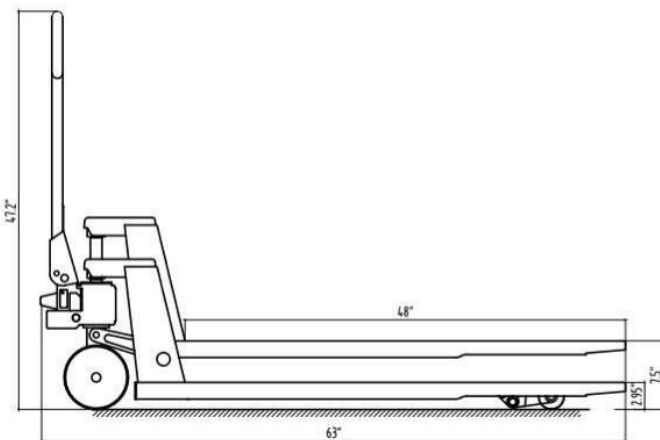

MODEL #	LOAD CAPACITY	FORKS	SERVICE WEIGHT
A25	5500lbs	27x48	160lbs