



# Operations & Maintenance Manual

## Lithium Pallet Jack

EP15JLI/EP18JLI/EP20JLI

EP15JLIC/EP18JLIC/EP20JLIC





## **Warning**

**Before using this Pallet Jack, first pay attention to the following matters: :**

- **Please read this manual carefully and operate the vehicle safely.**
- **Do not operate this vehicle without training.**
- **Please comply with ISO3691 "Safety Specification for Motor Vehicles Industry".**
- **Please do not modify or modify parameters or adjust pressure without authorization. Damage to the vehicle will be your responsibility and you will lose our warranty.**
- **Overload is prohibited. The load weight and load center shall comply with the requirements of the parameter table in this manual.**
- **When the vehicle is used for stacking, the center of gravity of the goods must be within two cargo forks. Stacking loose goods is strictly prohibited.**
- **No standing is allowed on the forks.**
- **After operations are completed, the power should be turned off.**

**Special reminder: The company adheres to the strategy of innovation and sustainable development; therefore, it can improve the technology of its products. Therefore, we reserve the right to make changes and improvements to any product described in this specification without prior notice.**

# 1. Main parts overview

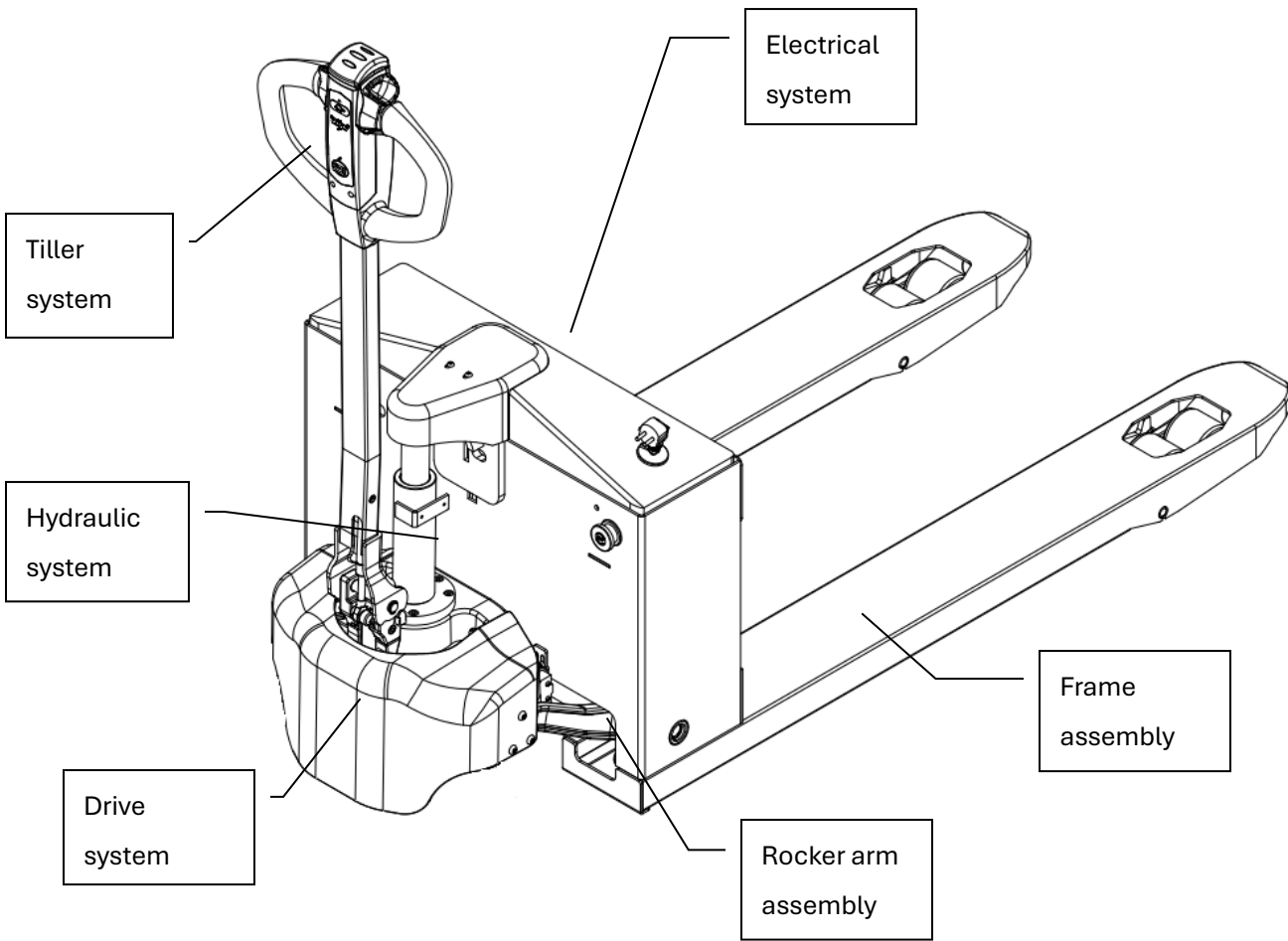

## 2. Main technical parameters

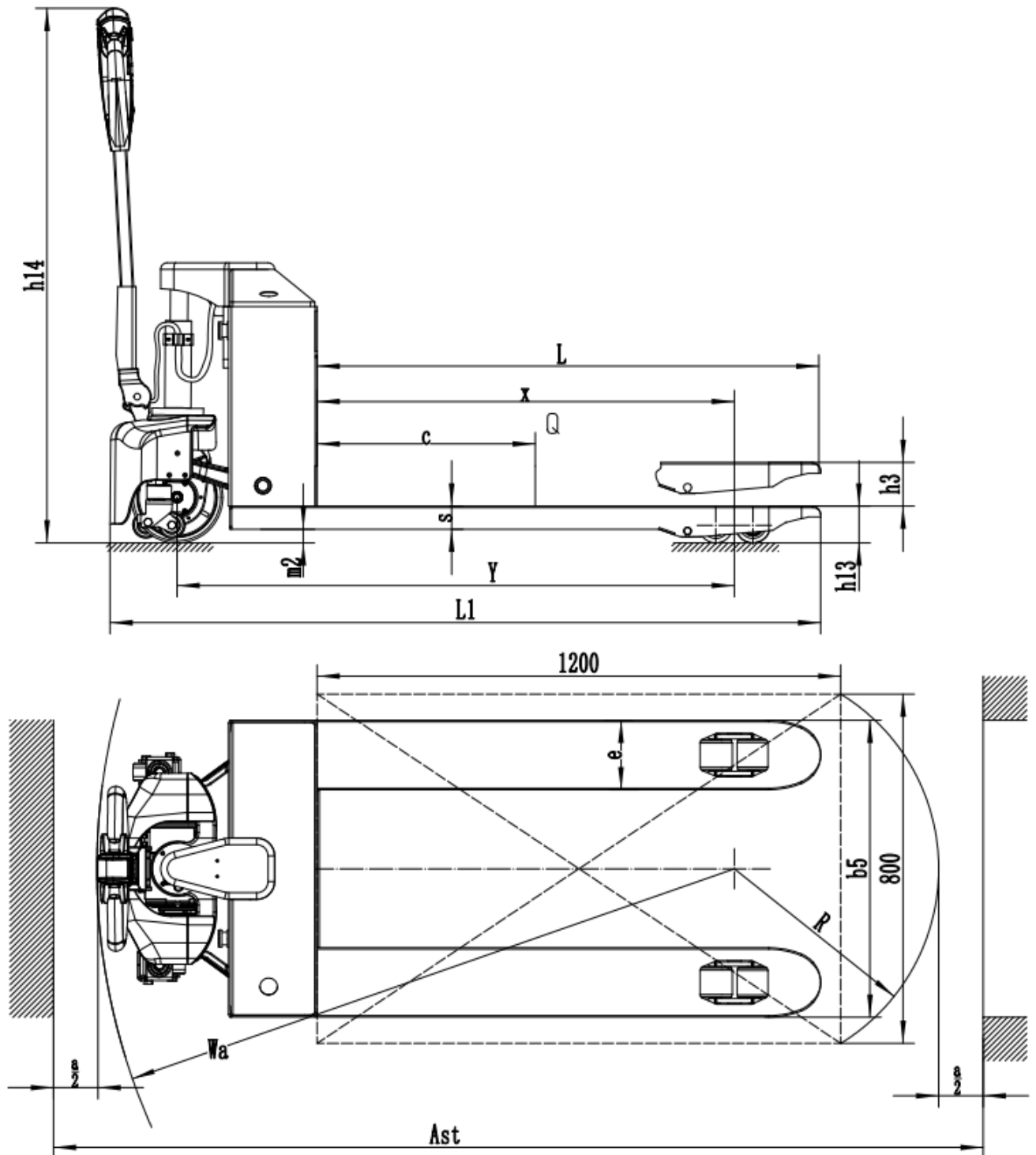

Figure 1-1

<b>Features</b>	<b>Model number</b>		EP15-18-20JLIC
	<b>Rated load</b>	Q(lbs.)	3,300 - 4,000 - 4,4000
	<b>Load center distance</b>	in.	24
<b>Weight</b>	<b>Service weight with battery</b>	lbs.	463
<b>Wheel</b>	<b>Front wheel</b>	in.	$\Phi 8.26 \times 2.95$
	<b>Rear-wheel</b>	in.	$\Phi 2.91 \times 3.66$
	<b>Wheel layout</b>		Three supports
<b>Dimensions</b>	<b>High height</b>	h3 (in)	7.48
	<b>Lowered height</b>	h13 (in)	2.9
	<b>Total length</b>	l1 (in)	64
	<b>Body width</b>	b1 (in)	26.7
	<b>Fork size</b>	s/e/l (in)	2.2 / 6.2 / 45.2
	<b>Outside width of forks</b>	b5 (in)	26.77
	<b>Turning radius</b>	Wa (in)	57.48
<b>Property</b>	<b>Highest/lowest dimensions of joystick</b>	h14 (in)	48.18
	<b>Travel speed, full/empty</b>	mph	2.6 / 2.8
<b>Electric machine</b>	<b>Climbing ability, full load/no load</b>	%	6 / 10
	<b>Drive motor power</b>	kw	0.75
	<b>Boost motor power</b>	kw	0.8
	<b>Battery voltage/rated capacity</b>	V/Ah	24/40

### 3. Use and usage environment

The electric pallet truck uses lithium batteries as the power source and cooperates with the DC drive system to implement electric driving and electric lifting. It has the features of labor saving, light weight, high efficiency, stability, simple operation, safety and reliability, low noise, and no pollution.

**Use environment:**

- a. Electric vehicles are suitable for use on hard and flat surfaces indoors but are not suitable for use on slopes and uneven surfaces. The ground should be free of pits and gravel that would interfere with wheel rolling.
- b. The altitude does not exceed 3,930 feet.
- c. Ambient air temperature shall not exceed +140°F, not lower than -77°F.
- d. When the ambient temperature is +140°F, the relative humidity is not more than 50%, and at lower temperatures, a larger relative humidity is allowed.
- e. It is prohibited to use the pallet jack in flammable and explosive, or acid and alkali corrosive environment.

## 4. Instructions for use

Correct use and operation of the vehicle will bring great convenience to your work. Improper operation and use of the vehicle will damage the vehicle or bring danger to your personal safety and cargo.

Before use, please check whether the vehicle is normal: whether the hydraulic pipeline is leaking oil, whether each set of wheels is intact and normal, and whether there is any jamming. The use of defective vehicles is prohibited.

### 4.1. Instrument desk

There is a power switch on the instrument bench, which is the basic control of the vehicle, as shown in Figure 2-1.

4.1.1 Power switch: When lightly pressing the power-off button, turn the power-off button clockwise about 5 to 10 degrees, and the button will automatically move upward, which turns on the vehicle's main power supply. Press the off button again and the power is cut off.

4.1.2 Magnetic switch: magnetic key can operate the vehicle.

4.1.3 Only after the power switch and electric door lock are turned on, the electricity meter will display the battery status, which is displayed by the four-color indicator light.

A. If the indicator of the meter is green, the power supply is sufficient.

B. The indicator of the meter is blue, indicating that the power supply is sufficient for normal use.

C. Meter indicator light shows yellow, indicating that there is still a small amount of power, please pay attention to charging.

D. Meter indicator light shows red, indicating insufficient power supply, please charge immediately!

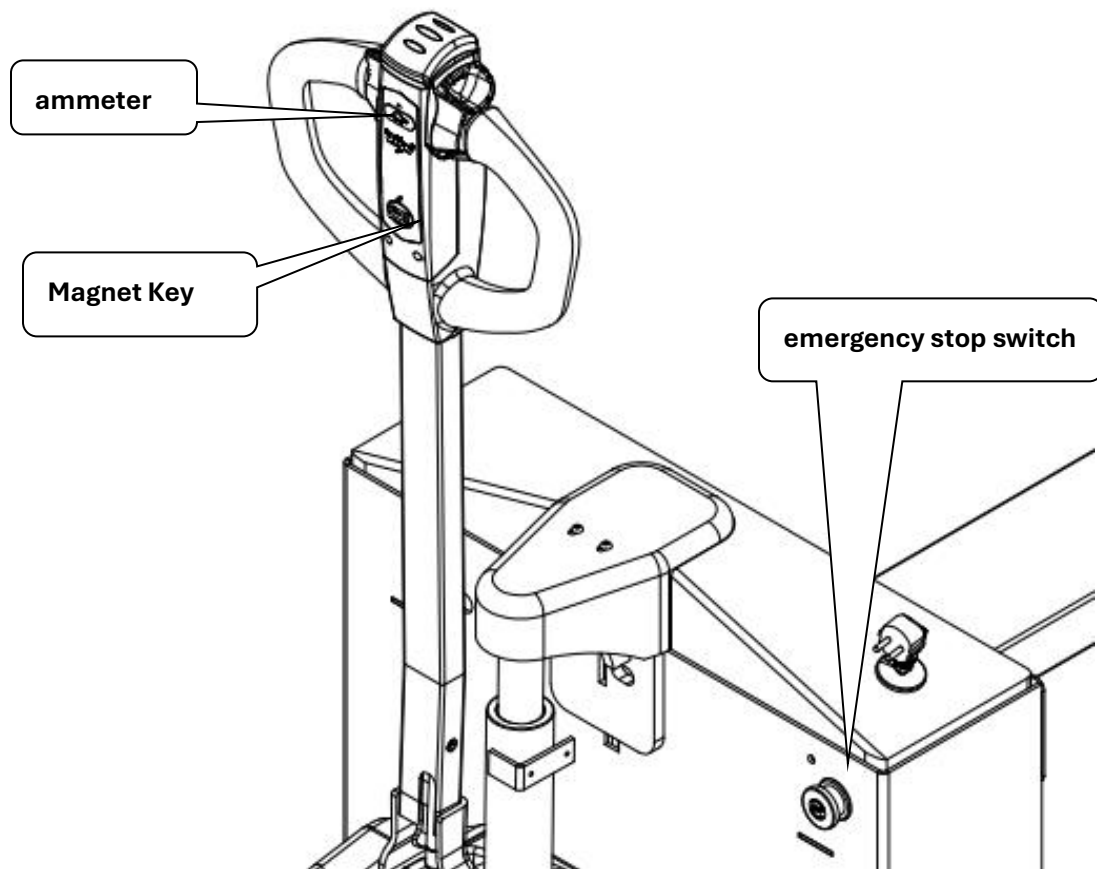

Figure2-1

#### 4.2. Forward driving and reverse driving

The flower-shaped turning knob located above and left of the rudder handle is used for running speed control. It can be operated with the left-hand thumb or the right-hand finger in a single action or at the same time, as shown in Figure 2-2.

a Push the speed button forward, the vehicle to move forward, the speed is proportional to the Angle, release the finger, the speed button will return to 0 position, the vehicle will gently stop.

b Push the speed button down and back, the vehicle moves backward, the speed is proportional to the Angle; after releasing the finger, the speed button will return to 0 position by itself, and the vehicle will stop gently.

#### 4.3 Emergency Reverse Switch

The red button at the top of the rudder handle is an emergency reverse switch, as shown in Figure 2-2.

When this switch is touched, the vehicle will reverse course.

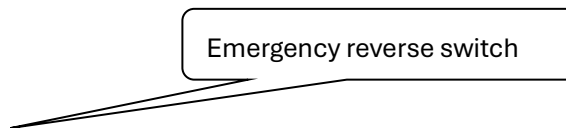

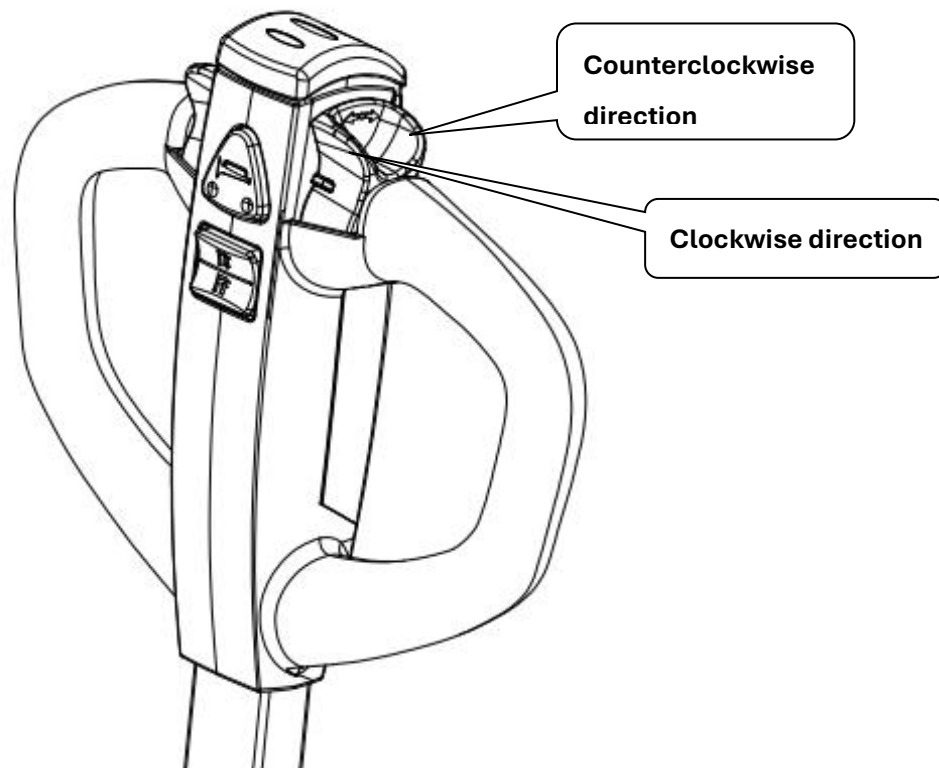

Figure 2-2

#### 4.4 Lift and drop switches and horn buttons, as shown in Figure 2-3

The lift button is located on the right side above the rudder handle. Press this switch to make the fork move upward.

The drop button is located on the left side above the rudder handle. Press this switch to make the fork drop.

The horn button is located in the middle above the rudder handle. Press this switch to sound the horn.

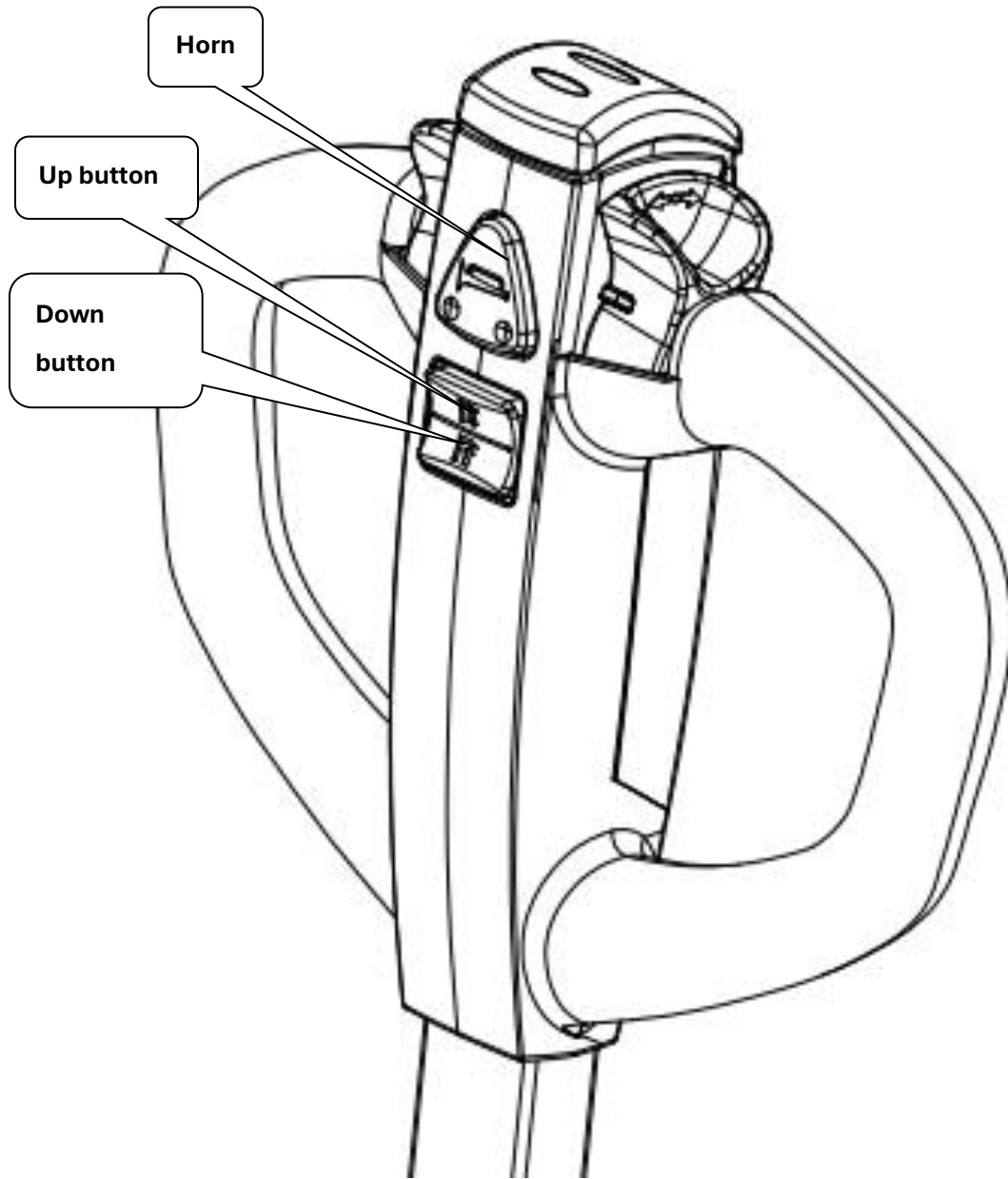

Figure 2-3

#### 4.5 Running and braking

The rudder handle is divided into three sections A, B and C in the vertical plane, and the two zones A and C are the braking zones.

When the rudder handle is located in zone A or zone C, the vehicle is in the braking state.

If the rudder handle is located in area B, the vehicle is in normal running condition.

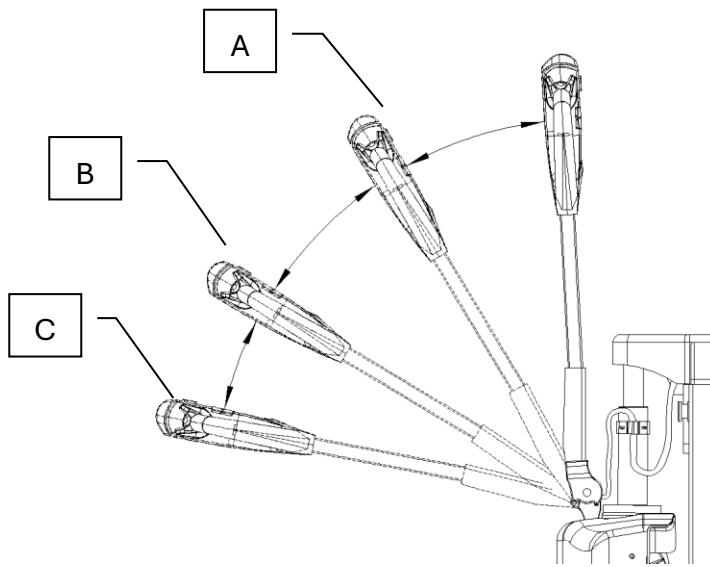

Figure 2-4

#### 4.6 Vehicle Running

The direction of the vehicle is controlled by the rudder handle. See Figure 2-5

a Turn the rudder bar to the left and the vehicle turns to the left.

b Turn the rudder bar to the right and the vehicle turns to the right.

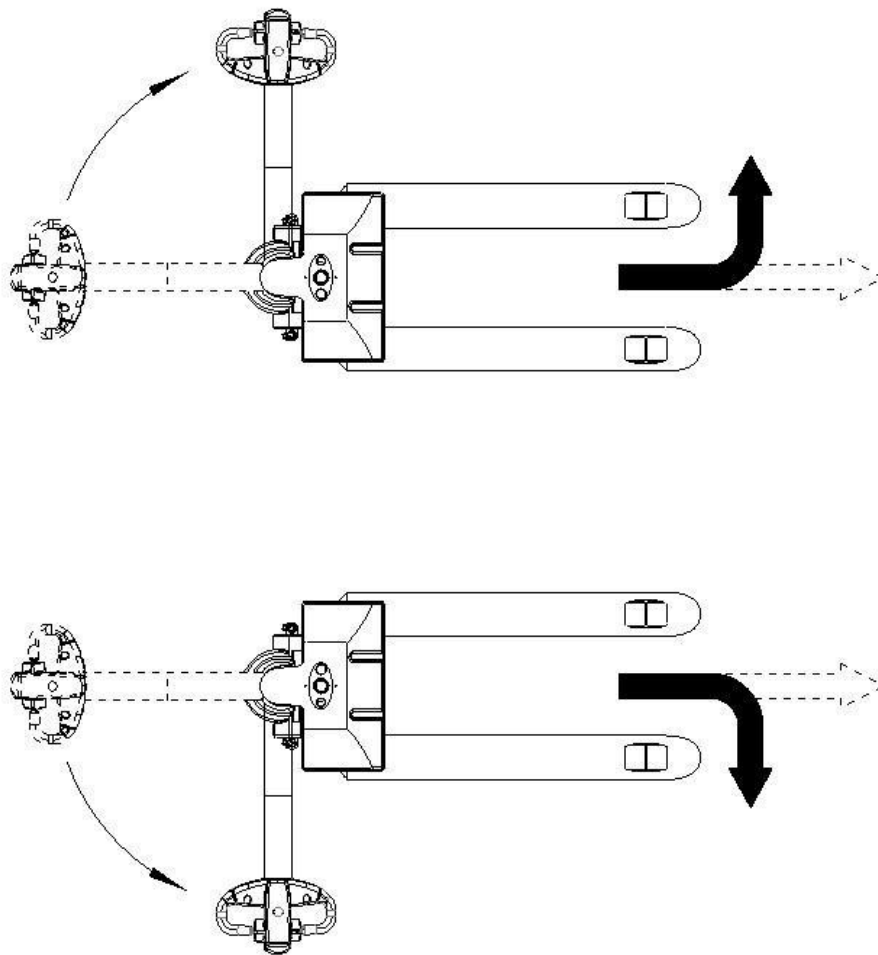

Figure 2-5

## 5. Use and maintenance of lithium batteries.

- (1) Do not put the battery pack into water or get it wet!
- (2) Do not charge the battery pack under fire or extreme heat conditions! Do not use or store battery packs near heat sources such as fire or heaters! If the battery leaks or gives off an odor, remove it immediately from near an open flame. When using a battery for the first time, fully charge the battery before using it.
- (3) Do not reverse the positive and negative terminals!
- (4) Do not put the battery pack into the fire or heat the battery pack!
- (5) Do not use wires or other metal objects to short-circuit the positive and negative batteries!
- (6) It is prohibited to pierce the battery pack housing with nails or other sharp objects, and it is prohibited to hammer or pedal the battery pack.
- (7) Disassembly of battery packs and cells in any way is prohibited! .
- (8) Do not use battery series in parallel.
- (9) Do not use the battery if it has an odor, heat, deformation, discoloration or other abnormality; if the battery pack is being used or charged, remove it from the device or charger immediately and stop using it.
- (10) Do not use battery packs in extremely hot environments, such as direct sunlight or inside a truck on a hot day. Otherwise, the battery pack will overheat, which will affect the performance and shorten the service life of the battery pack.
- (11) The ambient temperature will affect the discharge capacity, when the ambient temperature exceeds the standard environment ( $77 \pm 41^{\circ}$  F), the discharge capacity will be reduced.
- (12) Battery pack in the charging process, if there is an odor or abnormal sound, please stop charging immediately.
- (13) When the battery needs to be stored for a long time, please charge the battery to about 50% of the electricity (after the discharge, charge 1~2 hours with the charger (100A)), put it in a dry and ventilated place, and charge it for 1~2 hours with the charger every 2 months.
- (14) Battery pack and charger should be stored in a clean, dry, ventilated place, should avoid contact with corrosive substances, away from fire and heat sources
- (15) If the above phenomenon occurs, please contact the manufacturer, do not disassemble.

## 6. Typical faults and troubleshooting

Symptom	Trouble Reason	Troubleshooting
Battery with no-output	Battery output cable is not connected	Connect the output line properly in accordance with the specifications
	Battery pack is out of power	Charging the battery pack
Battery pack cannot be charged	Charger output plug loose	Check the charger output plug and battery plug is firm or not
	Battery pack is fully charged	Battery pack can be used normally

## 7. Possible faults and troubleshooting methods during use

Fault Description	Fault Cause	Solution
Oil leakage or leakage	The sealing washer is damaged or invalid, and the thread joint is loose	Replace the new seal ring and tighten the joint
The lifting height does not meet the design requirements	There's not enough hydraulic fluid in the tank	Add hydraulic oil
Fork not rising	The oil circuit is blocked or damaged	Repair or replace
Fork not rising (gear pump not working)	The lifting microswitch is loose or damaged	Adjust or replace
	The motor or line is faulty	Overhaul
The fork does not fall after it rises	Hydraulic station solenoid valve out of control	Repair or replace
The truck cannot stop while it is moving	The contactor contacts are damaged and the moving contacts are misaligned.	Cut off the power supply and replace the contactor contact

## 8. Packaging and transportation

The vehicle is packed in/on wooden pallets and is not allowed to be turned over or inverted during transportation. It is strictly prohibited to collide with the vehicle when lifting and loading it. Take care to not damage the exterior of the vehicle when unpacking.



# 10. Electrical schematic diagram

