



# Operations & Maintenance Manual

Electric Straddle Stacker

EB14C-118/138

EB14C-98LI/118LI/138LI/145LI

EB14CS-118LI/138LI/145LI



## **Instructions for use**

Please read this manual carefully and operate the vehicle safety.

- Do not operate this vehicle without training.
- Please comply with ISO3691 “Safety Specification for Motor Vehicles Industry”.
- Please do not modify or change the repair parameters, including adjusting the pressure. Any loss or damage to the vehicle resulting from such actions will be your responsibility, and doing so will void our warranty commitment.

### **SPECIAL WARNING:**

The company is committed to innovation and sustainable development. As part of this commitment, we continually improve the technology of our products. Therefore, we reserve the right to make changes and improvements to any product described in this specification without prior notice.

# 1. Main parts overview

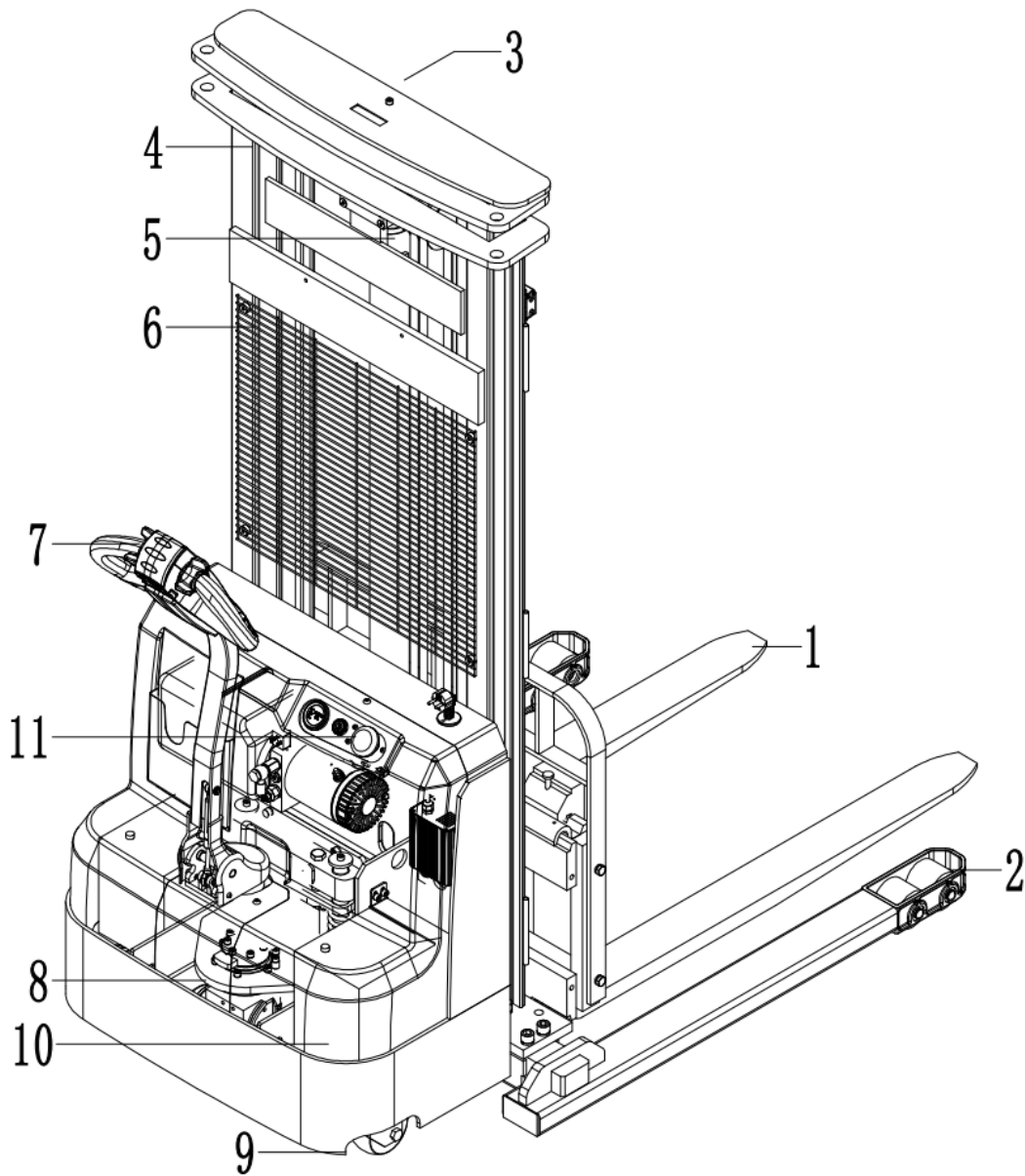

| Item no. | Description   | Item no. | Description           |
|----------|---------------|----------|-----------------------|
| 1        | Fork          | 7        | Handle                |
| 2        | Loading wheel | 8        | Drive wheel           |
| 3        | Inner mast    | 9        | Balance wheel         |
| 4        | Outer mast    | 10       | Battery               |
| 5        | Oil pump      | 11       | Emergency stop button |
| 6        | Mesh guard    |          |                       |

## 2. External drawing

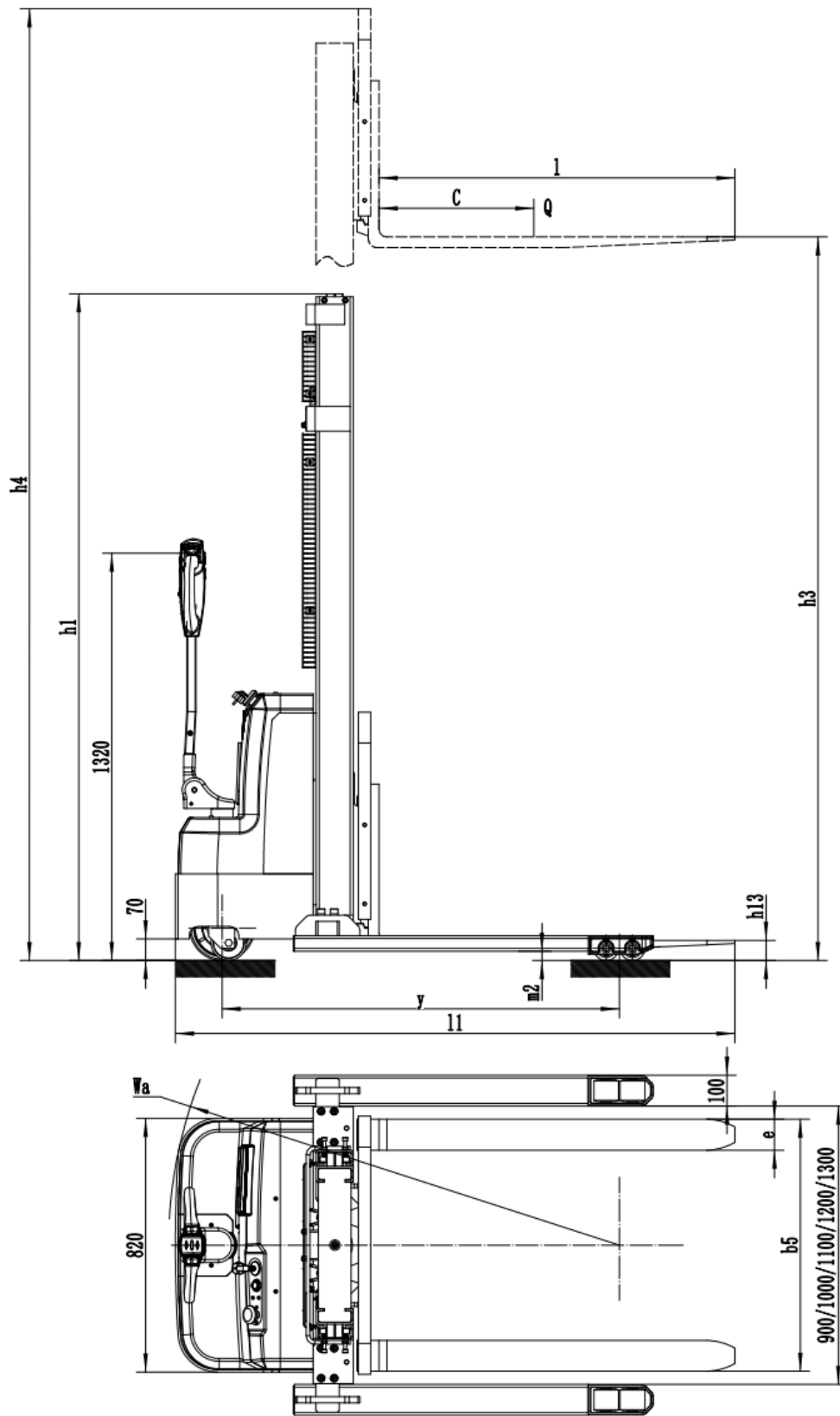

Figure 1-1

### 3. Main technical parameters

|                  |     |  |            |   |                       |
|------------------|-----|--|------------|---|-----------------------|
| Trait            | 1.1 | Model number                               |            | EB14C   | EB14CS (Side Shift)   |
|                  | 1.2 | Driving mode                               |            | Electric (battery)                                |                       |
|                  | 1.3 | Driving mode                               |            | WALKIE  |                       |
|                  | 1.4 | Rated load                                 | Q(lbs.)    | 2860  |                       |
|                  | 1.6 | Load center distance                       | c(in)      | 20  |                       |
| Wheel            | 4.1 | Lifting height                             | h3(in)     | 98/118/138/145                                    | 118/138/145           |
|                  | 4.2 | Height when mast is lowered                | h1(in)     | 75.2/85/94.8/98.81                                | 81.6/91.5/95.47       |
|                  | 4.3 | Maximum vehicle height during operation    | h4(in)     | 127.5/147.2/167/174.8                             | 147.2/167/174.8       |
|                  | 4.2 | Lowered fork height                        | h13(in)    | 2.5   |                       |
|                  | 4.3 | Overall length                             | l1(in)     | 73.7  |                       |
|                  |     | Inner leg width                            | (in)       | 35.4/39.4/43.3/47.24/51.2                         |                       |
|                  | 4.5 | Fork size                                  | S/e/l (in) | 1.37/3.93/45.2                                    |                       |
|                  | 4.6 | Outer width of forks                       | b5(in)     | 8.6~32.08   |                       |
|                  | 4.7 | Minimum ground clearance                   | m2(in)     | 1.18  |                       |
| Dimension        | 5.1 | Drive speed                                | Mi/h       | 2.48/2.48   |                       |
|                  | 5.2 | Lift speed, laden / unladen                | in/s       | 3.7/5.1   | 3.93/4.92             |
|                  | 5.3 | Slope Gradability                          | %          | 5/10  |                       |
|                  | 5.4 | Service brake                              |            | Electromagnetic - regenerative braking            |                       |
| Performance data | 6.1 | Drive motor power                          | kW         | 0.75  |                       |
|                  | 6.2 | Boost motor power                          | kW         | 2.2   |                       |
|                  | 6.3 | Battery voltage/rated capacity             | V/Ah       | Lithium battery 24/50<br>Lead-acid battery 24V/85 | Lithium battery 24/50 |
| Electric machine | 7.1 | Noise level at driver's ear meets DIN12053 | dB(A)      | <70   |                       |

## 4. Purpose and scope of use

The electric straddle stacker is powered by a battery and features a DC drive system for electric walking and lifting. It is designed to be labor-saving, lightweight, efficient, stable, simple to operate, safe, reliable, low-noise, and environmentally friendly.

Use environment:

- a. The stacker is suitable for use on hard, flat indoor surfaces and is not designed for slopes or uneven terrain. The ground should be free of pits or gravel that could hinder wheel movement.
- b. The operating altitude should not exceed 3,937 feet.
- c. The ambient air temperature should not exceed 104°F and should not drop below -13°F.
- d. At an ambient temperature of 104°F, the relative humidity should not exceed 50%. At lower temperatures, higher relative humidity is permissible.
- e. The stacker must not be used in flammable, explosive, or corrosive environments with acid or alkali exposure.

## 5. Instructions for use and operation

Proper use and operation of this vehicle will enhance efficiency and convenience in your work. However, improper operation or misuse may result in damage to the vehicle or pose risks to personal safety and cargo.

Before use, inspect the vehicle to ensure it is in proper working condition. Check for oil leaks in the hydraulic system, verify that all wheels are intact and function correctly, and ensure there are no obstructions or signs of malfunction. **Do not use the vehicle if any faults are detected.**

### 5.1. Instrument panel

The instrument panel includes a power switch, USB charging port, charging plug, and indicator lights. These serve as the primary controls for the vehicle, as illustrated in Figure 2-1.

5.1.1 Power switch: To turn on the vehicle, gently press the power button and rotate it clockwise approximately 5–10 degrees. The button will automatically pop up, indicating that the vehicle's main power supply is connected. To turn off the power, press the button again.

5.1.2 Charging plug: The vehicle features a built-in charger with a spring wire design. Simply pull out the plug to charge.

### 5.1.3 The indicator lights include:

- Charging Indicator: Displays the charging status.
- Fault Indicator: Alerts you to any issues with the stacker.

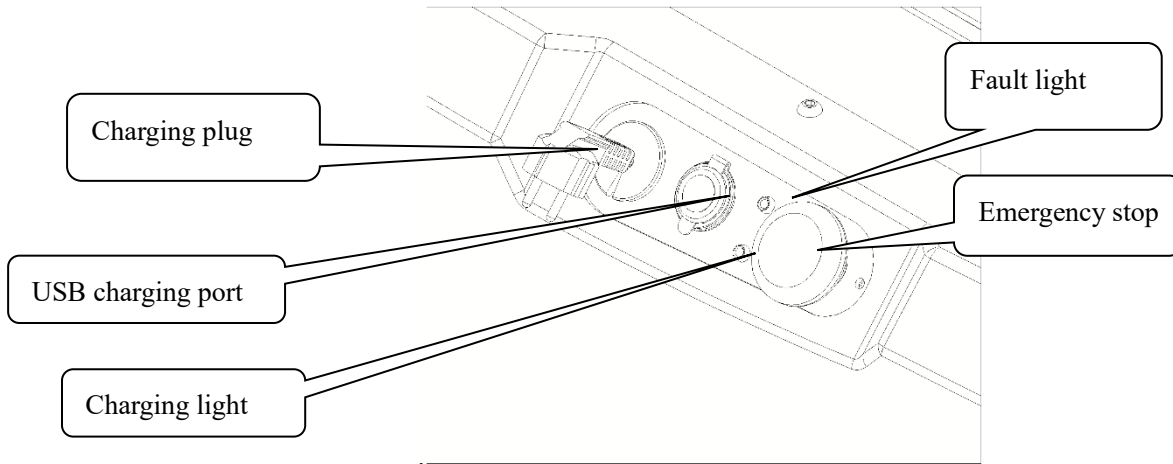

Fig 2-1

## 5.2. Forward and reverse driving

The flower-shaped turning knob, located above and to the left of the rudder handle, is used for speed control. It can be operated using the left-hand thumb or the right-hand fingers, either individually or simultaneously, as shown in Figure 2-2.

### A. Forward Driving

- Push the speed control button forward to move the vehicle forward. The speed is proportional to the angle of the button.
- When you release the button, it will automatically return to the 0 position, and the vehicle will come to a smooth stop.

### B. Reverse Driving

- Push the speed control button downward and backward to move the vehicle in reverse. The speed is proportional to the angle of the button.
- When you release the button, it will automatically return to the 0 position, and the vehicle will gently stop.

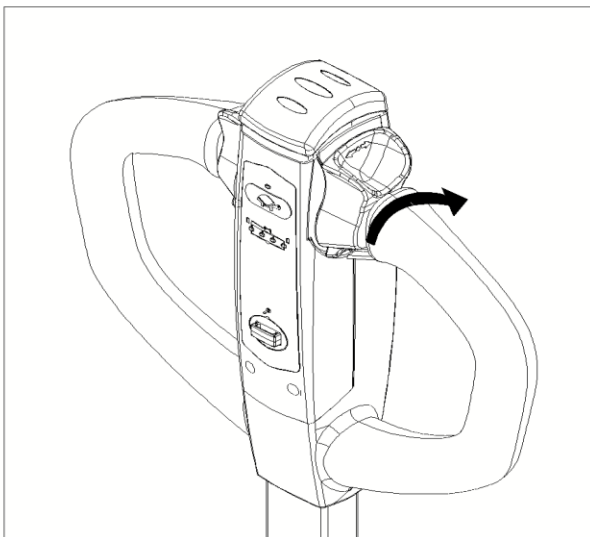

Turn forward

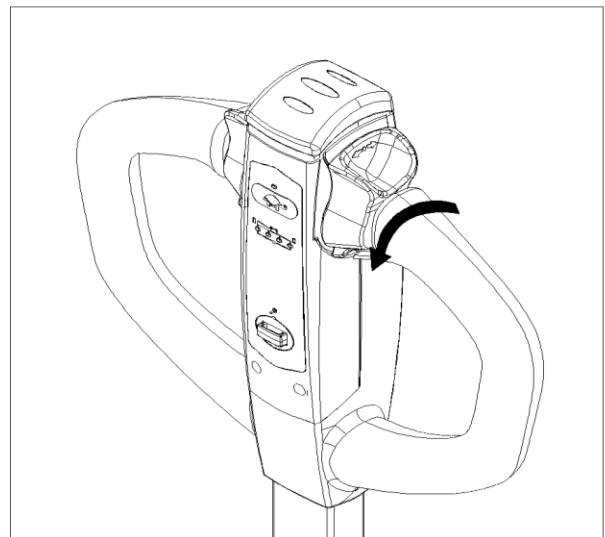

Turn backward

Figure 2-2

### 5.3 Emergency Reverse Switch

The red button located at the top of the rudder handle serves as the emergency reverse switch, as shown in Figure 2-3.

When this switch is activated, the vehicle will immediately reverse direction.

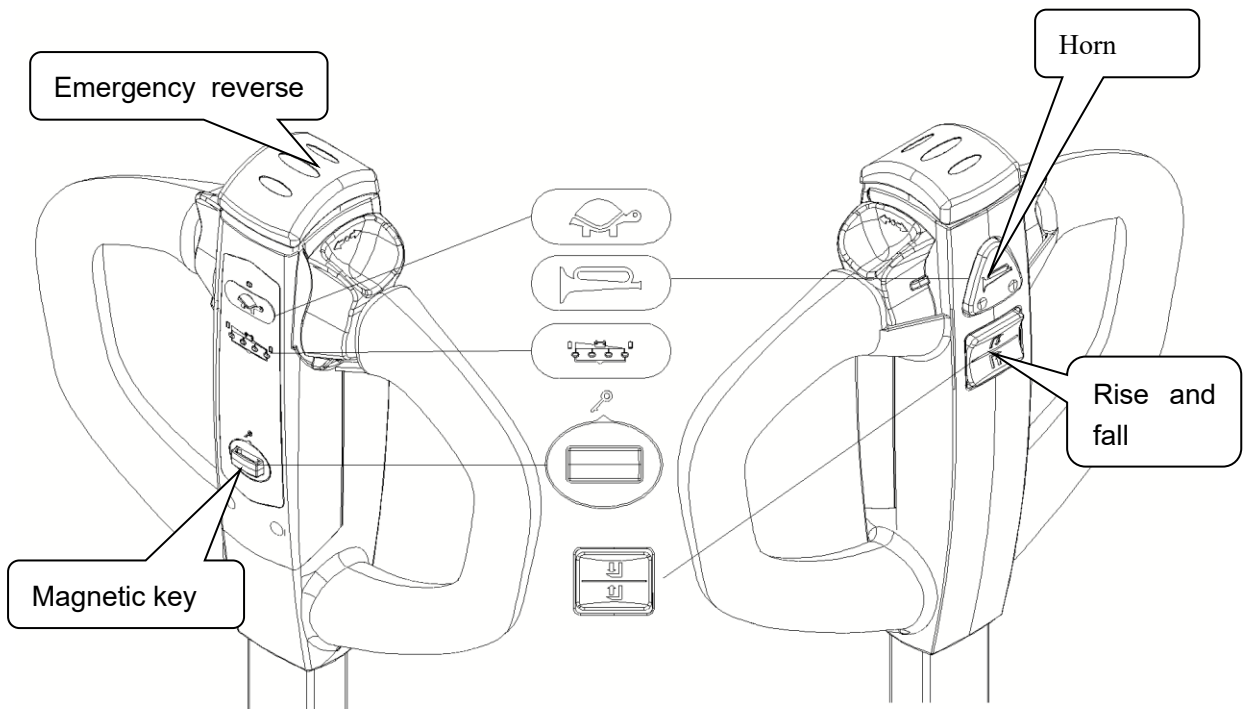

Figure 2-3

### 5.4 Lift and Drop Switches, and Horn Button

The lift and drop switches, along with the horn button, are located as shown in Figure 2-4:

- The **lift button** is positioned on the right side above the rudder handle. Press this switch to raise the forks.
- The **drop button** is located on the left side above the rudder handle. Press this switch to lower the forks.
- The **horn button** is in the center above the rudder handle. Press this switch to sound the horn.

Figure 2-4

### 5.5 Driving and Braking

The rudder handle operates in three vertical zones: **A**, **B**, and **C**:

- **Zones A and C** are braking zones. When the rudder handle is in either of these positions, the vehicle is in a braking state.
- **Zone B** is the normal operating zone. When the rudder handle is in this position, the vehicle is in a driving state.

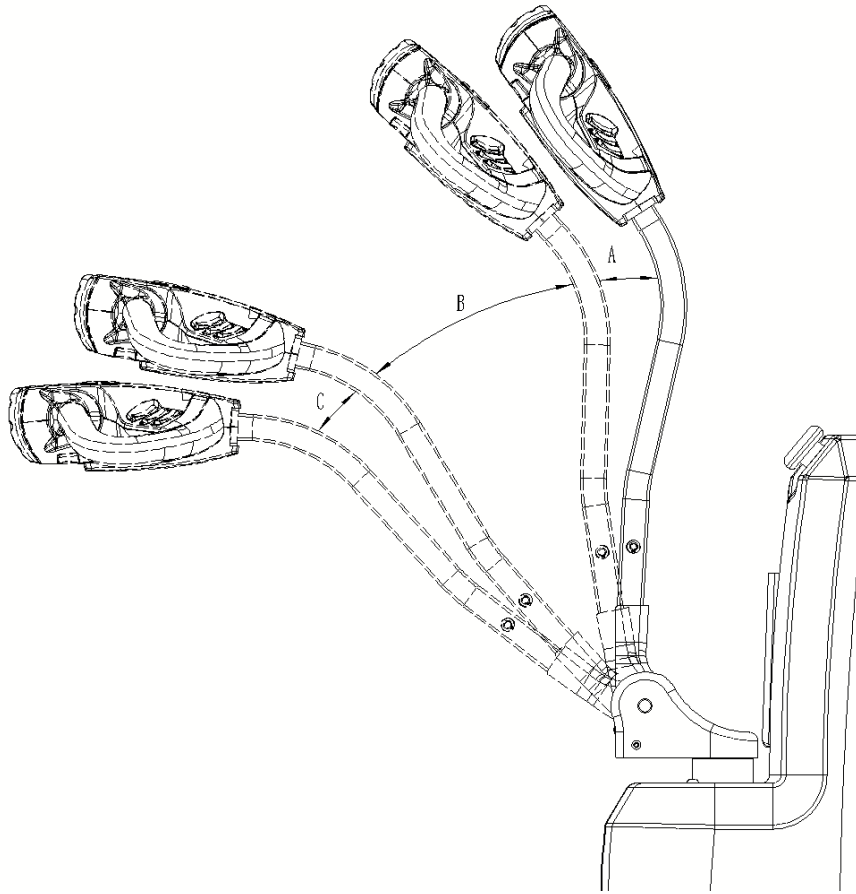

Figure 2-5

## 6. Use and Maintenance of Batteries

**Timely Charging:** Ensure the battery is fully charged regularly. Avoid letting the battery drain completely before charging, as excessive discharge can damage the battery.

**Connection Check:** Frequently inspect the battery connections to ensure they are secure, and the terminal surfaces are clean for proper contact.

**Safe Cleaning:** Avoid using dry cloths or fibers to clean the battery surface, as static electricity could cause an explosion.

**Exhaust Vent Maintenance:** Ensure the battery exhaust vent is not blocked. In winter, prevent it from being sealed by ice or water, as this could increase internal pressure and cause the battery casing to burst.

**Avoid Metal Near Terminals:** Keep metal objects away from battery terminals to prevent short circuits or ignition that could damage the battery.

**No Short-Circuit Testing:** Never use a short-circuit ignition method to test the battery's power.

**Storage Maintenance:** If the battery is not used for an extended period, disconnect or remove the negative terminal. Store the fully charged battery in a dry, frost-free location, and recharge it monthly to maintain readiness.

**Use the Proper Charger:** Always use the charger provided with the vehicle. Using other chargers may damage the battery.

**Prevent Physical Damage:** Protect the battery from external mechanical forces to avoid damage.

Replacement Consistency: Use replacement batteries identical to the original. Using incompatible batteries may harm the vehicle.

Proper Disposal: Dispose of old batteries according to local laws and regulations for recycling. Do not discard them improperly.

## 7. Possible faults during use and troubleshooting methods

Table 2 shows common troubleshooting methods for reference in fault diagnosis and maintenance.

| No. | Breakdown  | Cause analysis   | Elimination method  |
|-----|--|--|---|
| 1   | The meter does not display after the power switch is turned on.  | The 10A fuse on the panel of the electrical box is blown or the power switch is damaged. | Replace the fuse or power switch.   |
| 2   | The lifting height does not meet the design requirements.  | There's not enough hydraulic fluid in the tank.  | Add hydraulic oil.  |
| 3   | The hydraulic station motor is running, but the fork cannot lift or lowers improperly.                 | The solenoid valve of the hydraulic station is blocked or stuck with dirt.               | Remove solenoid spool and clean with gasoline or kerosene.  |
| 4   | After turning on the power switch, the power indicator is active, but the lifting fork does not raise. | The lifting loop 175A fuse is blown or the battery protection controller is damaged.     | Replace the fuse or battery protection controller. If it is replaced and broken, check whether the circuit is short circuiting, or the device is damaged. |
| 5   | Oil leakage or leakage   | The sealing washer is damaged or invalid, and the thread joint is loose                  | Replace the new seal ring and tighten the joint   |

Table 2

## 8. Packaging and transportation

The stacker is packed in a palletized wooden box and must not be overturned or flipped upside down during transportation. Avoid collisions while lifting and loading the vehicle. When unpacking, take care not to damage the external surface of the stacker.

## 9. Warning (Precautions)

9.1 Before operating the stacker, please read the instructions and familiarize yourself with the stacker's performance.

9.2 To avoid damage to the goods and the stacker, do not press the lifting and lowering buttons while the vehicle is moving, and avoid switching between the lifting and lowering buttons quickly or frequently.

9.3 This unit is an electric stacker and does not require shaking the handle in rapid or high-frequency motions!

9.4 Do not quickly load heavy objects onto the fork.

9.5 Overloading is strictly prohibited. Do not carry additional weight or exceed the operating load, as this increases the risk of accidents.

9.6 The center of gravity of the load should be positioned evenly between the two forks. Otherwise, the forks may be damaged, or the load may fall during operation. Reduce the load if it is unbalanced.

9.7 Do not load loose or unstable cargo!

- 9.8 Do not leave the goods on the stacker for extended periods!
- 9.9 Sharp turns in narrow passages are strictly prohibited. Slow down and turn gradually to ensure the safety of personnel and cargo.
- 9.10 When the stacker is not in use, lower the forks to their lowest position to avoid injuring pedestrians with the forks.
- 9.11 Do not place any part of your body under heavy objects or forks!
- 9.12 The stacker is suitable for use on flat surfaces or flat work platforms. Long-term parking on slopes is strictly prohibited. Do not perform high-altitude or heavy-duty operations on uneven terrain.
- 9.13 Overloading or driving on inclines is strictly prohibited. This could cause the wheels to slip, damaging the wheels, motor, goods, and endangering personal safety.
- 9.14 Each stacker connector should be protected from exposure to rainwater. If water intrusion occurs, wipe it off promptly.
- 9.15 It is strictly prohibited to use the stacker below the specified voltage of 20.4V.
- 9.16 Unless the stacker has a built-in charger, it is strictly prohibited to connect the stacker directly to external AC power.
- 9.17 This vehicle is a station-driven electric stacker; do not operate it while standing, for your safety and comfort.
- 9.18 Unauthorized repairs are strictly prohibited without proper training.
- 9.19 When the lifting height of the fork exceeds 19.7 inches, the vehicle must travel at the minimum speed, and the continuous distance traveled should not exceed 6.6 feet.

# 10. Electrical schematic diagram

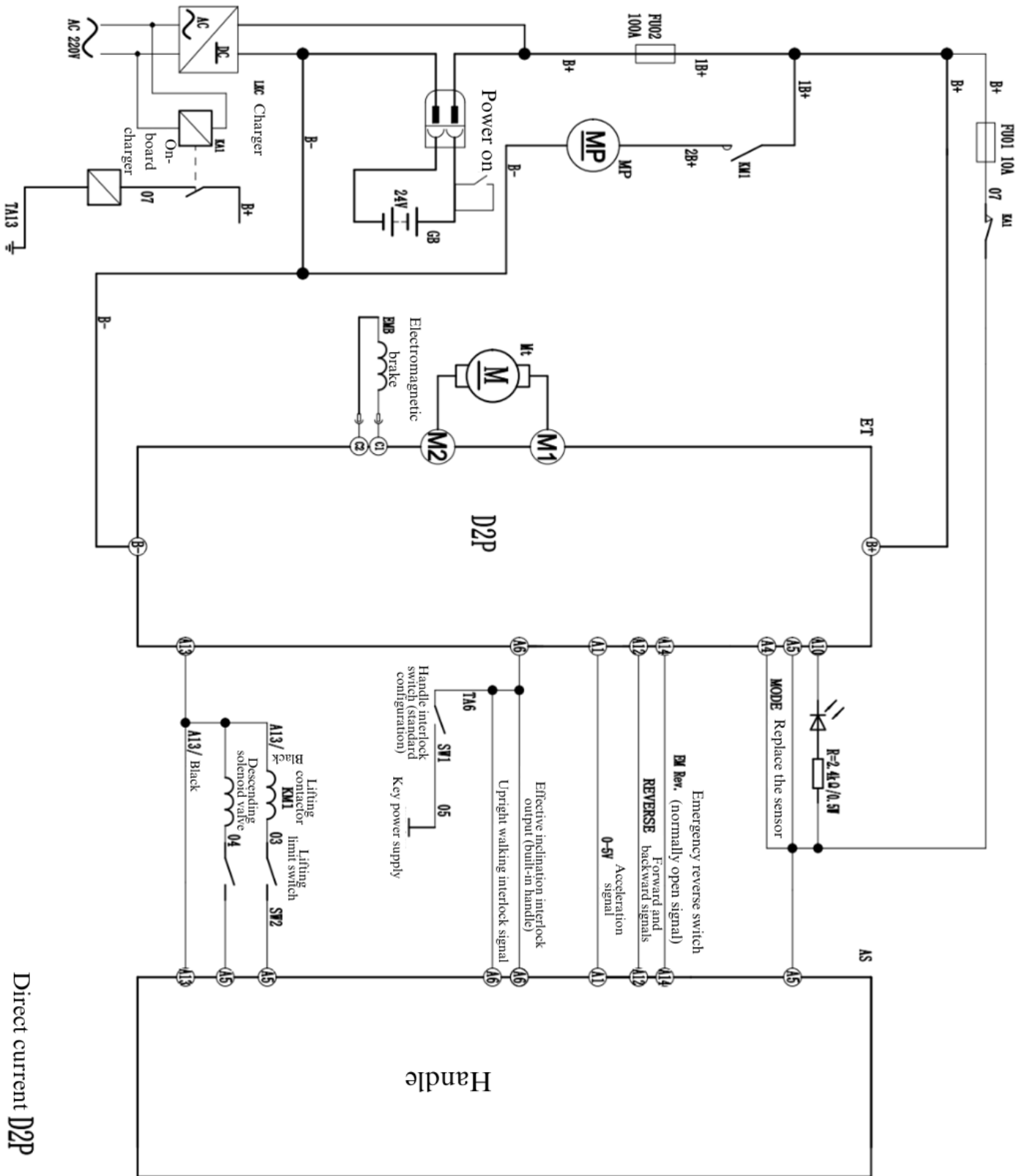

# 11. Hydraulic schematic diagram

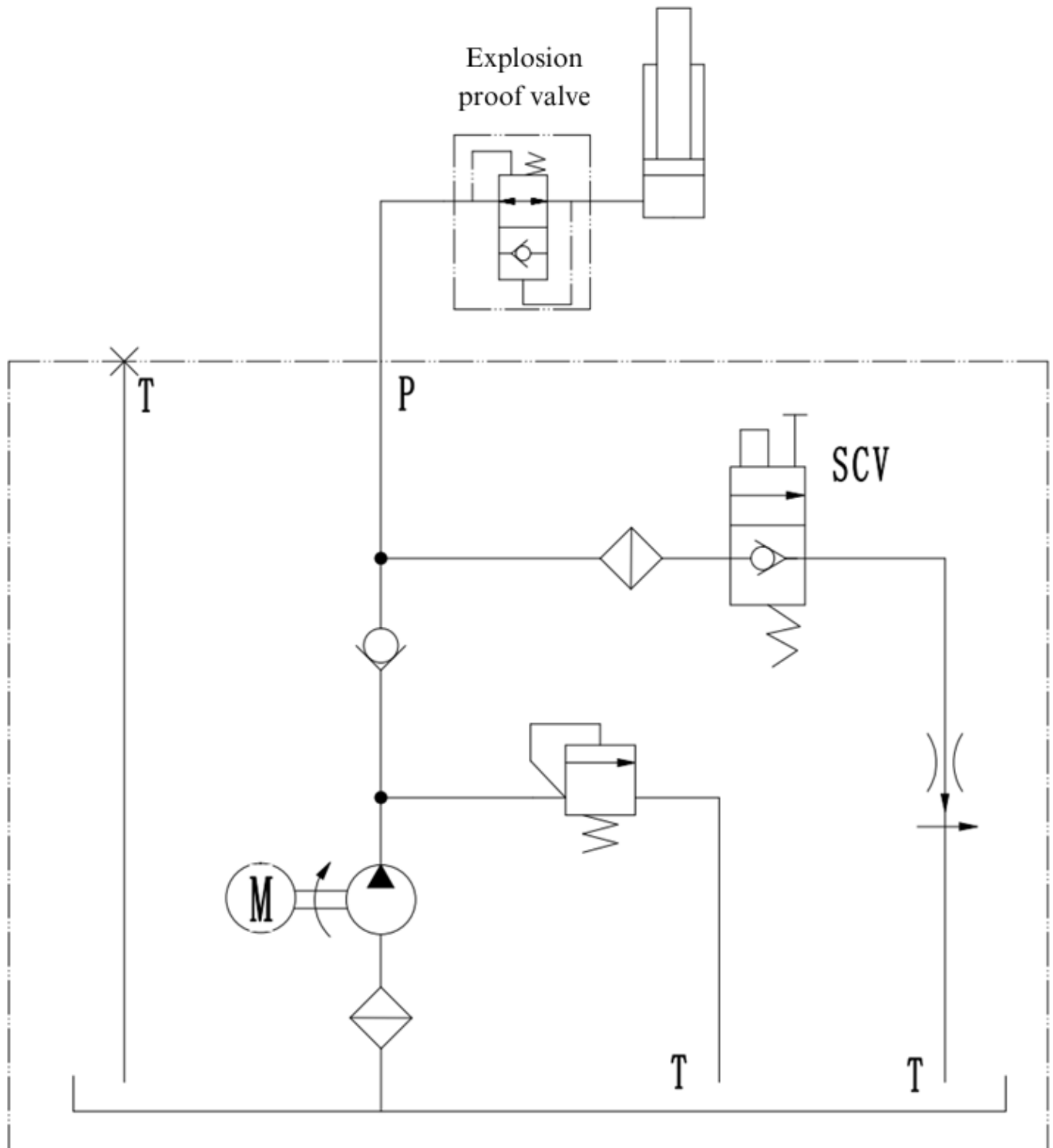

1. oil tank 2. oil filter 3. DC motor 4. gear oil pump 5. relief valve 6. check valve 7. Electromagnetic reversing valve 8. built-in balancing valve 9. cylinder