



**Operations &
Maintenance Manual
Lithium 4-Wheel Forklift**

GT-LI Series

**EK20GT-LI / EK25GT-LI
EK30GT-LI / EK35GT-LI**



1. ISSUES ABOUT SAFETY

CONTENTS

FOR SUPERVISORS.....	1 - 1
PROPER AND IMPROPER USES.....	1 - 2
PLANNING AND WORKING AREA.....	1 - 3
TRAVELING ON PUBLIC ROADS.....	1 - 6
OPERATORS	1 - 7
TYPES OF VEHICLES AND LOADS.....	1 - 9
INSPECTION	1 - 12
INSPECTION/TRANSPORTING THE LIFT TRUCK.....	1 - 13
HOW THE LIFT TRUCK WORKS.....	1 - 14
TRAVELING	1 - 17
LOAD HANDLING.....	1 - 22
PARKING.....	1 - 26
INSPECTION AND SERVICE.....	1 - 27
CAUTION PLATES.....	1 - 32

This manual and the decals affixed to the truck use the following safety alert indications.

SIGNAL WORD	CLASSIFICATION
⚠ DANGER	Failure to follow the instructions in the message will likely cause a serious accident or death.
⚠ WARNING	Failure to follow the instructions in the message might cause a serious accident or death.
⚠ CAUTION	Failure to follow the instructions in the message may cause personal injury or damage to the truck or other property.
👉 NOTE	The information will help to prolong the service life of the truck. The message is not directly related to accident prevention.

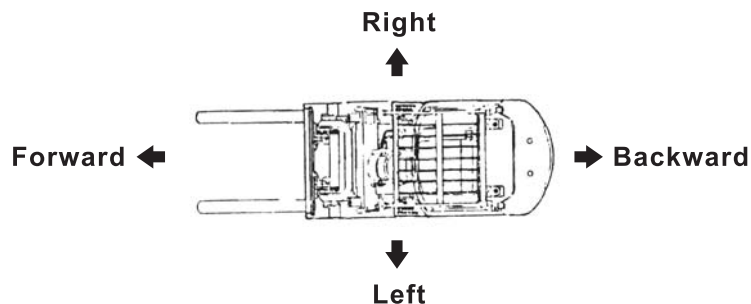

The diagram above indicates the meanings of the terms “forward”, “backward”, “right” and “left” used in this manual.

FOR SUPERVISORS

Lift truck accidents cause dozens or hundreds of deaths every year, and even greater numbers of personal injuries.

TEU has steadily improved the design and fabrication of our lift trucks so they may be used more safely and efficiently, but many accidents still occur due to improper use. Accidents are often the result of more than just “bad driving”, The use of inappropriate types of equipment, the selection of inappropriate attachments or accessories, inappropriate operating environments, careless designation of operators, and failure to properly train the operator are other common causes of accidents.

This chapter covers the methods of accident prevention which are primarily the responsibility of supervisory personnel.

Pages 1-2 through 1-13 contain instructions which should be enforced by the personnel supervising the operation of the lift truck. Please make sure the operators also read these pages.

Page 1-14 and the following pages contain specific precautions directly related to the operation of the lift truck.

■ **PROPER USE OF THE LIFT TRUCK**

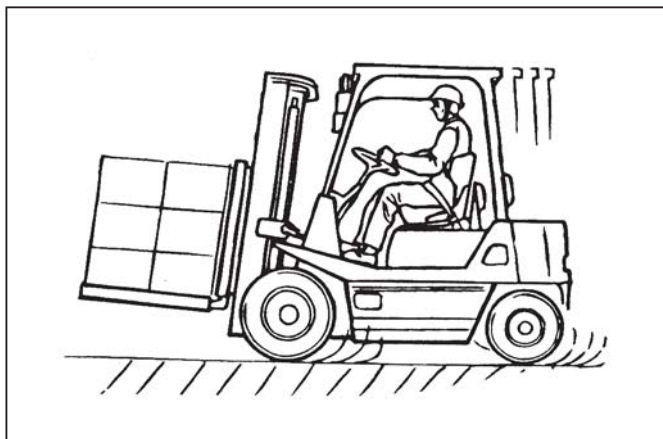

The proper use of a lift truck is to transport a load which is placed on the pallet and stacked within the prescribed height limit. With a proper attachment, a lift truck may be used to transport a load which is stacked elsewhere than on the pallet.

■ **IMPROPER USE**



Transporting a person, elevating a person, and towing another vehicle are examples of the improper use of a lift truck. Uses which this manual specifies as improper must never be requested or permitted, under any circumstances.

(Examples of Improper Use)

- Transporting or elevating a person on the forks or pallet.
- Carrying a person on the pallet to control the load.
- Hanging a cable on the forks to suspend a load.
- Towing another vehicle.
- Pushing a load or another vehicle with the forks.
- Using the forks or truck body to close or open the door of a freight vehicle.

■ **MAKE AN OPERATING PLAN AND DISCUSS IT**

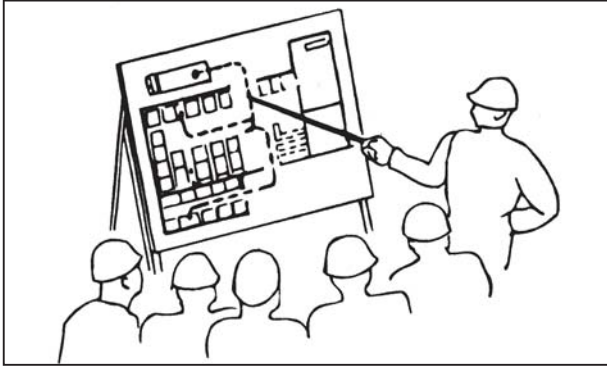

Before using the lift truck, plan out the travel routes and operating procedures, and thoroughly discuss the details with all personnel involved.

■ **SET SPEED LIMITS**

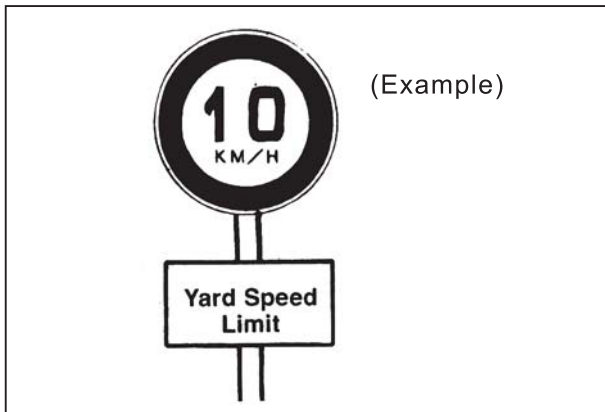

■ **INSTALL CURBS OR RAILINGS**



If the truck is to be used on a loading dock, shore wall or other raised surface, install curbs or railings.

■ **MARK THE TRAVEL LANES**

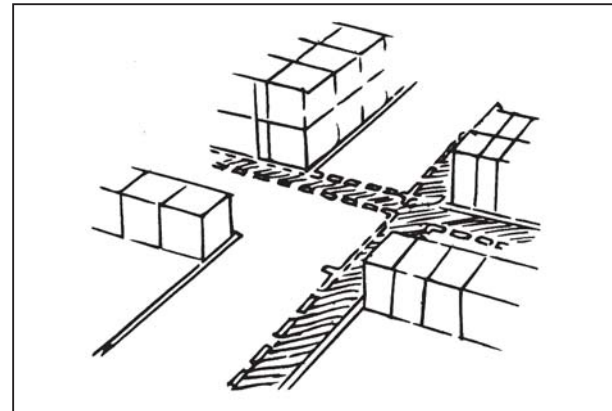

Designate the travel lanes for the lift truck and mark them

FOR SUPERVISORS PLANNING AND WORKING AREA

■ KEEP PEOPLE OUT OF THE OPERATING AREA



No other personnel should be allowed in areas where the lift truck is used.

Where other people must be present, post a guide whose job is to make sure people stay clear of moving vehicles.

■ KEEP UNAUTHORIZED VEHICLES OUT

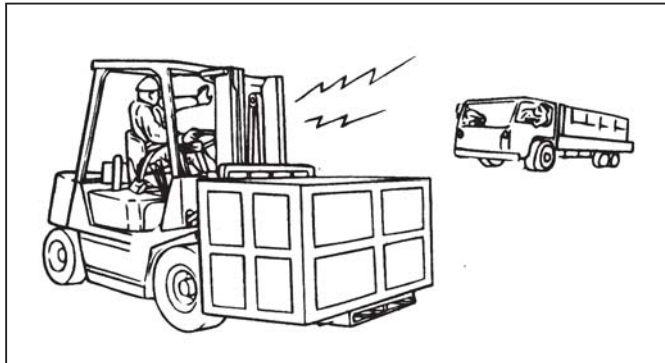

Unauthorized vehicles must be kept out of the load handling areas. Post signs or give signals as required.

■ KEEP THE GROUND LEVEL AND DRY

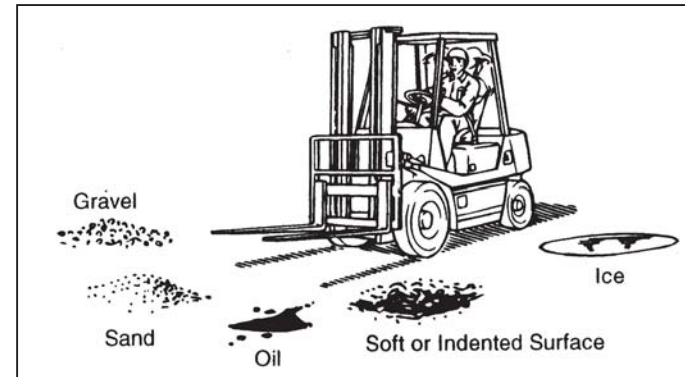

Be sure that all areas where the lift truck travels are level and regular. Clear away pools of oil or water.

■ PROVIDE ADEQUATE LIGHTING

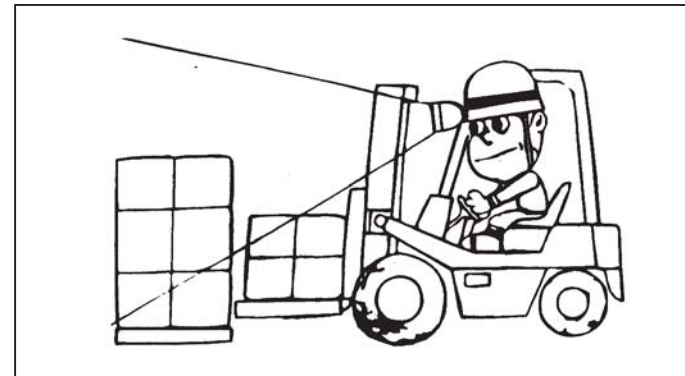

Safe operation requires well-lit traveling routes, so pedestrians and obstacles can be easily seen. Use headlights, taillights, helmet lamps or other lights as appropriate.

■ **ASSIGN TRAFFIC GUIDES TO CONGESTED AREAS**

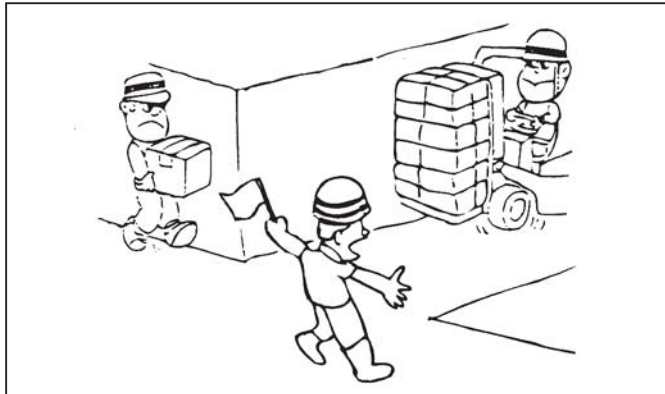

Post a traffic guide in confined or congested areas where other people or vehicles may pass. All personnel must obey the guide.

■ **KNOW WHO TO CALL IN AN EMERGENCY**

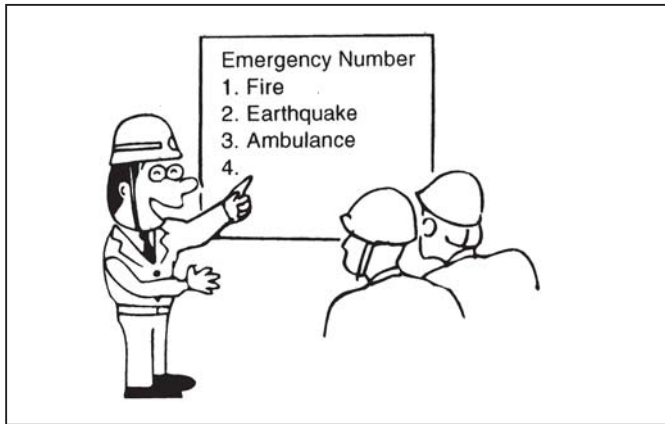

Keep information on hand to allow immediate calls for help in case of a fire, accident or other emergency.

■ **PROPER USE OF THE LIFT TRUCK**



Fire extinguishers and first aid kits should be provided and maintained for use in case of a fire or accident. All personnel should understand the location and use of emergency equipment.

■ **SAFETY MEASURES FOR DANGER SPOTS**



Post warning signs or take other appropriate measures to ensure

■ GOT A LICENSE?

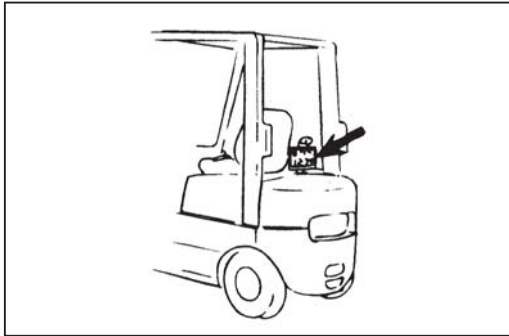

Before traveling on a public road, be sure that the truck has been licensed and inspected as required by local laws.

■ NO LOAD, NO TOWING

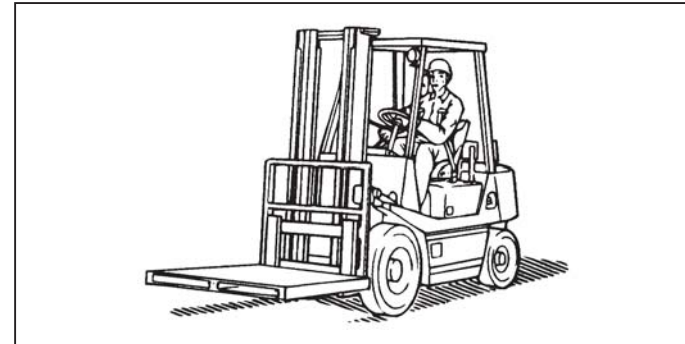

It is usually illegal to carry a load on a public road. It is also not allowed to tow another vehicle on a public road (with the possible exception of a disabled vehicle). Never tow another vehicle, even on company property.

■ OBEY TRAFFIC LAWS, AND TURN OFF YOUR LIGHTS

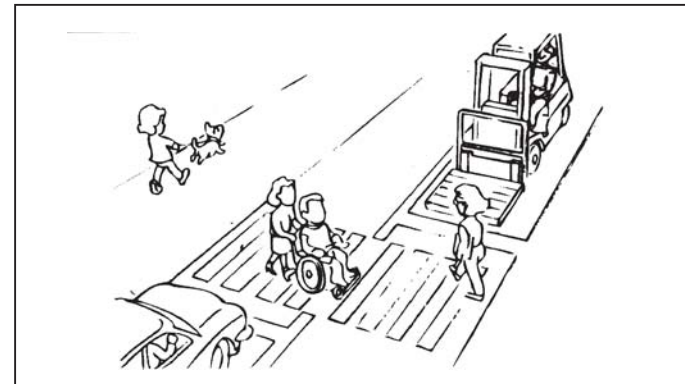

On a public road, the lift truck must obey the same laws as any other vehicle. Do not use rear working light or tail lamp.

WEAR PROTECTIVE GEAR

Always wear proper work clothes for driving. Work clothes should be designed to prevent any part from accidentally catching on knobs or other parts of the truck or equipment. For example, shirts and trousers should have tight cuffs.

Always wear a hard hat and safety shoes.

Wear other protective gear as appropriate to the conditions of the work site, i.e., Goggles or gloves.

■ TRAIN YOUR STAFF TO STACK SAFELY

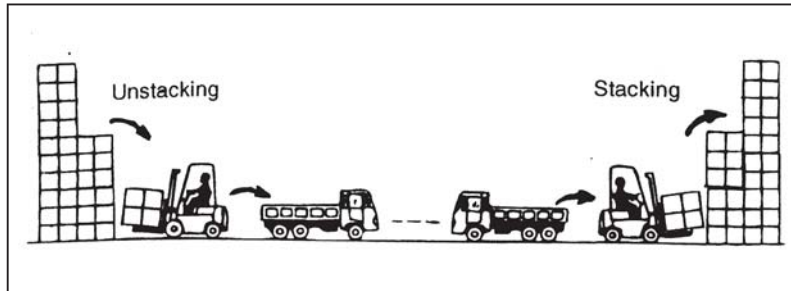

“Stacking” means piling palletted load or materials directly on top of each other, without using racks or shelves to separate them. If the stacking work is not done properly, the loads may slip or fall, endangering the operator as well as any other personnel in the area. Safety classes should be held to train all operators in the proper methods of stacking and unstacking loads. (Your TEU dealer can provide information about training for safe stacking.)

■ TIRED OR UNWELL? SEND THEM HOME!



Do not let people take chances. An operator who is overworked or fatigued, an operator who is feeling unwell, or an operator who is intoxicated must not be allowed in the driver’s seat.

■ USE THE RIGHT TRUCK FOR THE JOB

Be sure the type and capacity of the lift truck is suitable for the work environment.

Check Point	Choice
Capacity	Load capacities range from 0.5 to 42 tons. Pay particular attention to the load center. TEU Lift Truck Capacities: 0.5, 0.7, 0.9, 1, 1.35, 1.5, 2, 2.25, 2.5, 2.75, 3, 3.5, 4, 4.5, 5, 6, 7, 8, 10, 10.5, 11.5, 12, 13.5, 15, 18, 20, 22, 23, 24, 25, 30, 27, or 42 tons.
Power Source	Gasoline, natural gas, diesel, and battery-powered models are available. Fuel costs and exhaust composition will vary.
Balance	On counterbalanced models, the counterweight at the rear makes the vehicle longer than a reach truck. A reach truck performs loading and unloading by extending the front part of the mast outward, which gives it the advantage of compactness.
Tires	For indoor use, there are models with solid tires (best for reach trucks) and cushion tires (engine type or battery type). Both are compact. For outdoor use, pneumatic tires work well. Solid cushion tires, with the same dimensions as pneumatic tires, may be the best choice in cases where the load materials or surface conditions could puncture pneumatic tires.
Flammable Materials	For handling flammable materials such as petrochemicals, a combustion engine is too dangerous. An electric vehicle with explosion-proof or safety-reinforced construction is required. (A battery power source always offers better protection against fire than a combustion engine.)

■ USE THE PROPER ATTACHMENT

Popular Attachment Examples

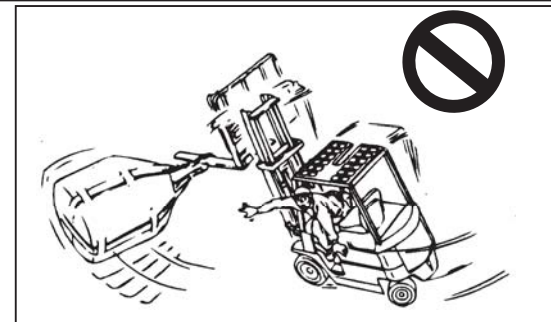
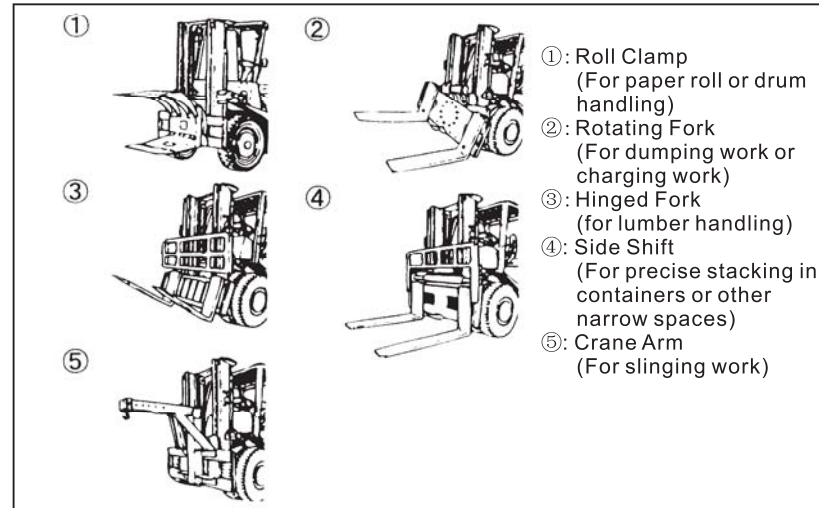

⚠ WARNING

Avoid hoisting a load with wire rope hung from the forks or an attachment, or avoid lifting a freight container with forks, because there is danger of the truck tipping. If necessary, have a qualified operator use a hook or crane arm attachment.

■ NO OPERATION WITHOUT LIGHTS, OVERHEAD GUARD, OR LOAD BACKREST

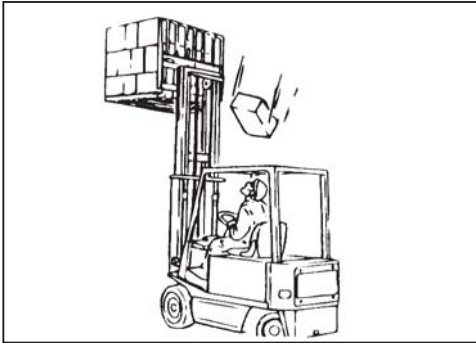

The lift truck cannot be used if the headlights, taillights, overhead guard, load backrest, horn or turn signals have been removed. Any parts that have been temporarily removed for some reason must be reattached immediately.

■ OBTAIN APPROVAL FOR ANY MODIFICATION



Modifications or additions that affect the capacity, construction or strength of the truck must not be performed by the user without the manufacturer's prior permission. For example, don't add a

■ DO NOT RELY ON THE OVERHEAD GUARD



The overhead guard is a protective device that will moderate the impact of an object falling from overhead, but it cannot withstand every impact. If a heavy object seems likely to fall on the truck, make every effort to prevent it from doing so.

■ USE STURDY PALLET MATERIALS

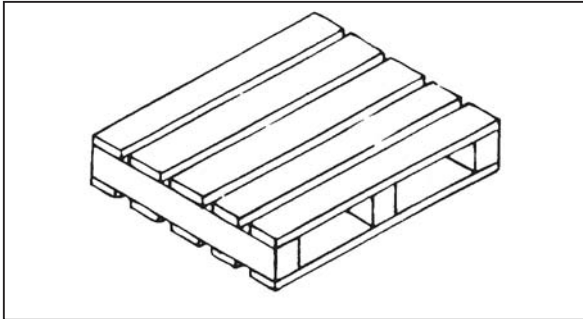

Pallets and skids must be strong enough to withstand the weight of loads. Remove or repair any damaged pallets.

■ STACK LOADS SECURELY

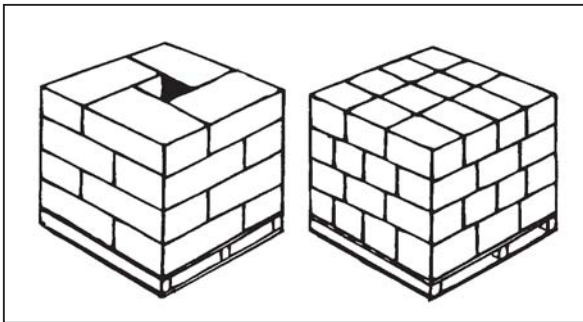

When stacking loads, place them in a stable manner that they will not easily come apart, and be sure the weight is evenly distributed. Secure the top layer with a cord wrapped like a headband or in a similar fashion.

■ KNOW THE LOAD BEARING CAPACITY OF THE FLOOR



The lift truck is heavier than it appears. For example, a 2-ton truck weighs almost 3.5 tons even when empty. Furthermore, when loaded, 80 to 90% of the total weight is concentrated on the front wheels. Check the strength of your floors and roadways, and if necessary reinforce them.

■ ALWAYS INSPECT BEFORE OPERATING

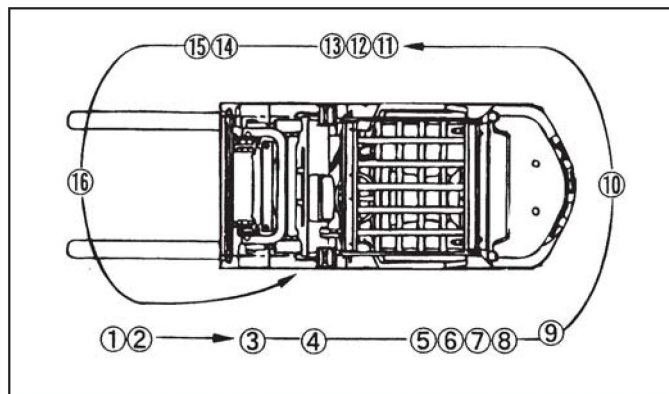

The operator should always inspect the truck before each use to verify that all essential safety features are working. Any abnormality is to be reported to the supervisor, who is responsible for correcting it.

■ PERIODIC INSPECTIONS ARE MANDATORY

Monthly and annual inspections must be performed thoroughly, and any abnormality promptly repaired. Only a certified expert who has the advanced skills and equipment is required to conduct the inspections. Preserve the inspection logs for at least three years.

■ REPLACE SAFETY PARTS REGULARLY

	Name of Safety parts	Recommended replacement interval(years)
1	Cups and dust seals of master cylinder and wheel cylinders	1
2	Power steering hose	2
3	Steering actuator rubber boots	2
4	Lift chain	2-4
5	Load handling means hoses	1-2

Certain critical parts must be replaced at regular intervals. Since it is difficult to detect wear on the above parts by visual inspection, they must be replaced after a certain period of time. Failure to do so would result in a falling load or runaway truck.

■ NEVER USE AN UN-MAINTAINED TRUCK

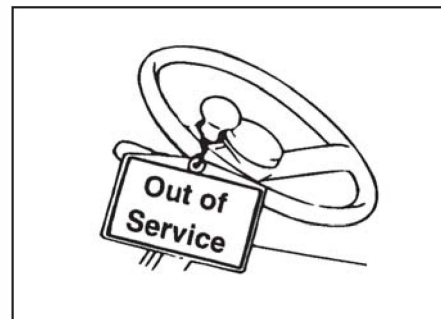

A truck that has not passed an inspection must never be operated. Hang a sign on the truck and remove the ignition switch, to make sure no one uses it. Then report the problem to the supervisor and wait for the repair to be completed.

■ DESIGNATE A REPAIR AND ASSEMBLY SUPERVISOR



Repairs and the mounting and dismounting of attachments must be performed under the direction of a designated supervisor. The body and major parts of the lift truck are quite heavy and under very high pressure. Repair or assembly work undertaken without careful and thorough preparation can lead to a serious injury.

■ TRANSPORTING THE LIFT TRUCK

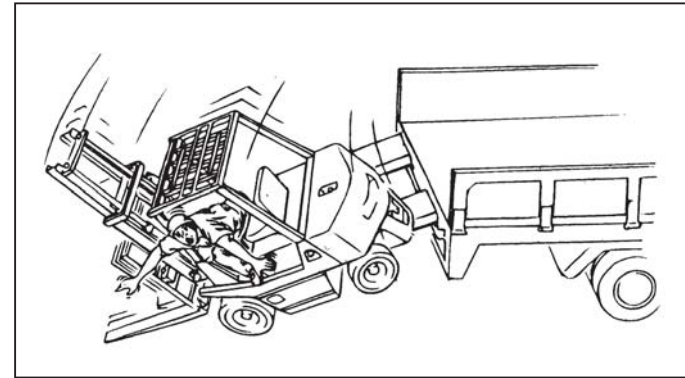

Use a level, hard road surface when loading the truck onto or unloading from a trailer. Be certain that the loading ramps have sufficient length and width as well as strength. Do not load or unload the truck when it is raining, unless the ramps are fitted with an anti-slipping surfaces.

It is safest to use a self-loading trailer truck equipped with a jack and winch. For loading, tilt the pallet with the jack, attach the winch to the towing pin of the lift truck, start the engine, and pull it up. The operator must not ride on the lift truck while loading or unloading.

HOW THE LIFT TRUCK WORKS?

■ KEEP PEOPLE OUT OF THE OPERATING AREA

Lift trucks are equipped with load handling means including a mast and forks at their front. The front wheels of the truck work as a fulcrum to balance the center of gravity of the truck and the center of gravity of the load. The relationship between the locations of those two centers of gravity is vitally important for safety.

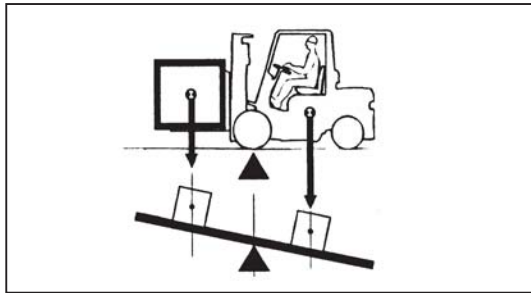

■ KNOW THE CENTER OF GRAVITY OF YOUR LOAD

Materials of various shapes such as boxes or flat or cylindrical items may be loaded on the lift truck. In order to accurately judge the stability of the truck, it is vitally important for the operator to know the location of the center of gravity for each type of load.

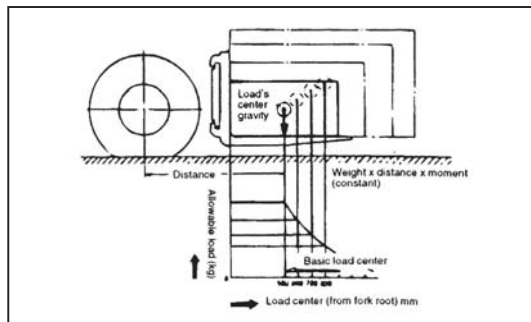

■ HOW THE CENTER OF GRAVITY SHIFTS

The stability of the lift truck is determined by the overall center of gravity, which is the product of the centers of gravity of the truck and the load. When the truck is empty, this point is the same as the center of gravity for the truck, and when it is loaded it shifts according to the center of gravity of the load. Since the center of gravity of the load changes whenever the mast is tilted forward or backward or the fork is raised or lowered, the overall center of gravity also changes. The center of gravity is also governed by the following factors.

- Size, weight and shape of the load
- Unloading height
- Tilt angle of the fork
- Tire inflation

- Acceleration, deceleration and turning
- Surface condition and gradient of the road
- Type of attachment

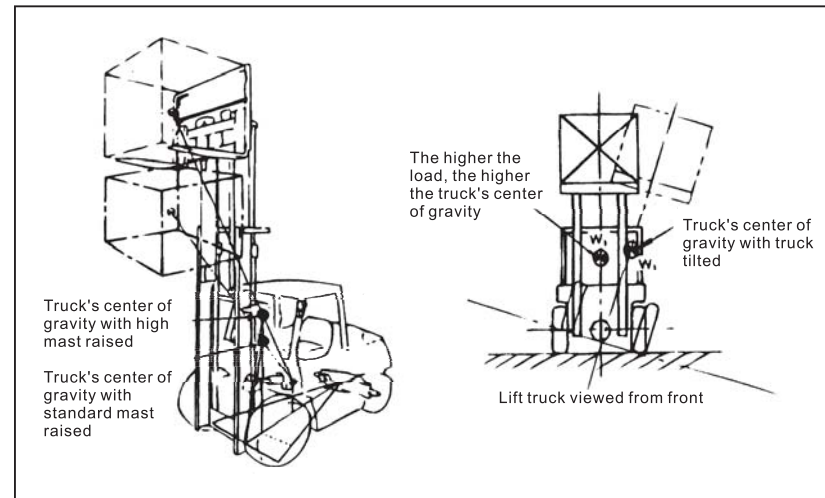

HOW THE LIFT TRUCK WORKS?

■ OUTSIDE THE TRIANGLE OF BALANCE, THE TRUCK TIPS

For a lift truck to remain stable, the overall center of gravity must be inside the triangle formed by the contact points of the left and right front tires and the center point between the steering wheels. The triangle defines the area of stability for the center of gravity. If the overall center of gravity moves further forward than the front wheels, the truck will tip forward with the front wheels as the fulcrum. If the overall center of gravity moves outside the triangle to the right or the left, the truck will fall over in that direction.

■ RATED LOAD (LOAD WEIGHT AND LOAD CENTER)

The load center is the distance from the front face of the forks to the center of gravity of the load. The rated load is the maximum weight allowable with the nominal load center.

The load Chart, showing the relationship between the load center and the rated load, is attached to the truck as a decal. The rated load decreases as the load center moves toward the tip of the forks and as the overall center of gravity moves forward.

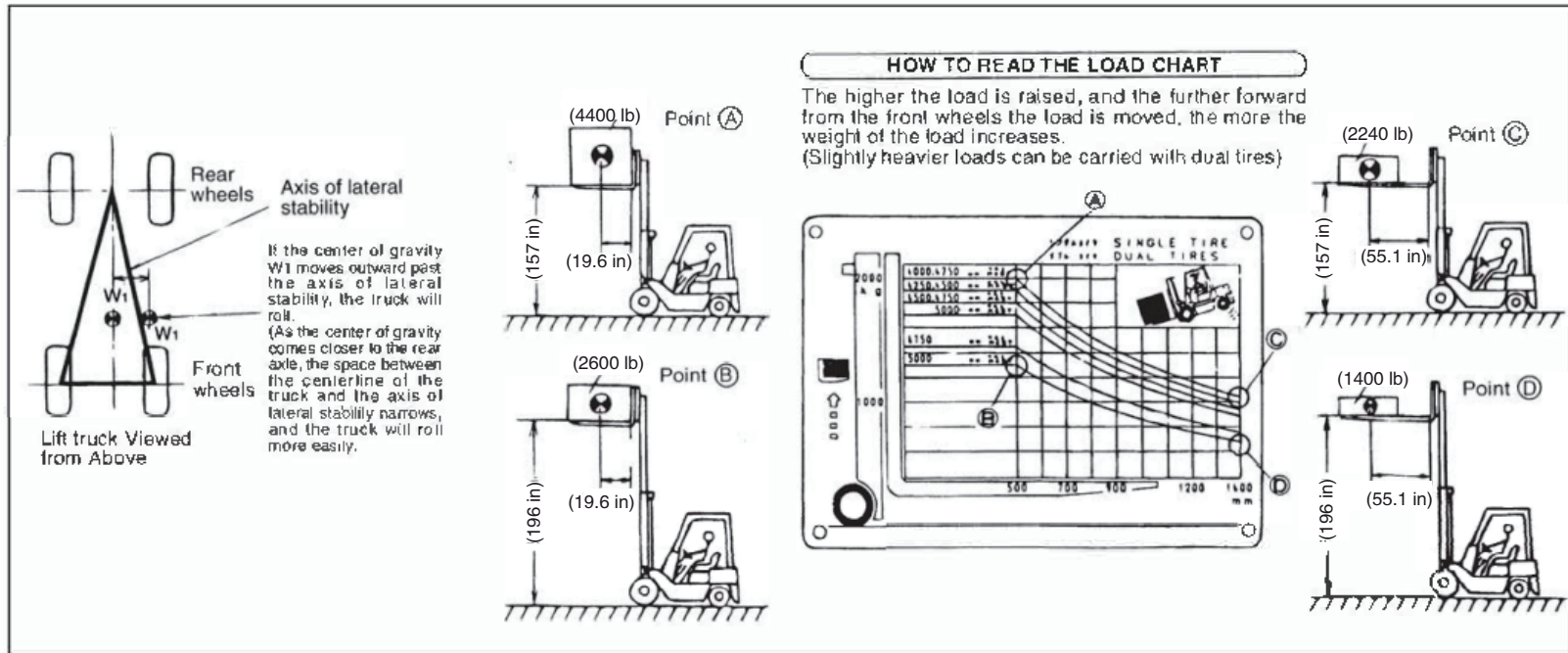

HOW THE LIFT TRUCK WORKS?

■ ACCELERATING, DECELERATING AND TURNING

The principle of inertia provides that a stationary object will remain stationary as long as there is no external force acting on it, and that a moving object will continue moving at a constant speed as long as there is no external force acting on it.

Due to inertia, when the lift truck starts to move there is a momentary backward force, and when it stops there is a momentary forward force. As a result, if the brakes are applied suddenly, there is a very strong hazard that the forward force will become strong enough for the truck to tip forward.

Likewise, when the truck is turning there is a centrifugal force that pulls it outward from the turning center. This force can cause the truck to fall sideways. Since the zone of lateral stability is especially narrow, it is necessary to slow down substantially when turning in order to prevent the truck from tipping.

When the load is elevated the overall center of gravity is raised, increasing the danger of the truck tipping over to the front or side.

⚠ Read manual and decals

Read the Operation & Maintenance manual and caution plates in the truck, and become familiar with your truck and operating procedures. Remember that individual lift trucks might be different in design and construction from one another. Observe the caution decals on the truck. Keep this Operation and Maintenance manual on the truck as a ready reference for anyone who may drive or service it.

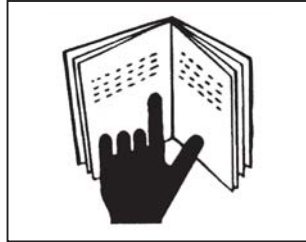

⚠ When starting

Before starting your lift truck (before turning the key switch on), make sure to:

- Apply the parking brake securely.
- Place the F/R lever in neutral.
- Press the brake pedal.

Adjust the steering column angle and driver's seat properly.

Do not try to adjust them during operation; otherwise a serious accident might occur. After adjustment, make sure they are securely locked.

Make sure there is no one under or around the truck and seat yourself on the driver's seat.

⚠ Before reversing the direction of travel, bring the truck to a complete stop

It is dangerous to reverse the direction of travel abruptly.

⚠ Carry the load low

It is dangerous to travel with forks lifted higher than is appropriate, regardless of whether loaded or not. Keep the load as low as possible while traveling. Do not turn the truck with the load raised high.

⚠ Keep the truck's center of gravity low while traveling (when loaded in particular)

When traveling (when loaded in particular), keep the forks 20cm above the floor or ground and tilted back, so as to lower the truck's center of gravity as far as possible.

⚠ Do not jerk the forks (lift, down, and tilt) when loaded

The truck might tip over.

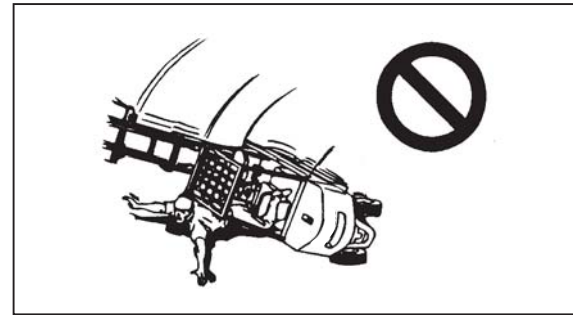

⚠ Avoid sharp starts, stops and turns

Start, stop and turn slowly. Before turning, slow down the truck sufficiently. In particular, an unloaded truck might tip over when it is turned sharply, because the rear of the truck is heavy.



TRAVELING

⚠ Back down and drive up on a slope

Do not make turns on a gradient. There is danger of the truck upsetting.

Keep the forks and pallet at an appropriate ground clearance height.

When operating an unloaded truck on grades, have the rear end of your truck pointed up-hill.

When operating a loaded truck on grades, have the rear end of your truck pointed down-hill.

When descending a grade, use the foot and regenerative brakes properly.

When descending a grade, never turn the key switch off.

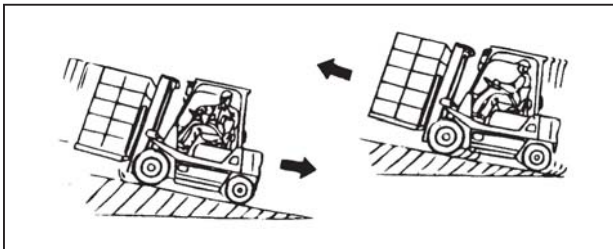

⚠ Stay away from the edge of road

There is a fear of the edge of a soft ground collapsing. Stay away from such a place. Keep appropriate distance from the edge of a narrow road or a platform.

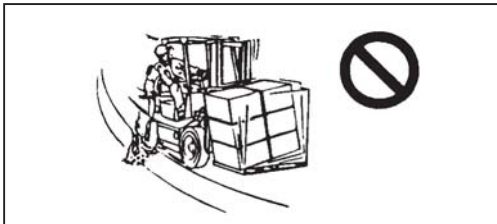

⚠ When driving over a dockboard

Do not ride on the edge of the dockboard or bridgeplates; otherwise the truck might fall down, leading to personal injury or even death.

Before driving over a dockboard or bridgeplate, make sure it is properly secured. Never exceed its rated capacity. Do not use a damaged dockboard or bridgeplate.

Have the brakes set and wheels blocks in place to prevent the trailer from moving.

Jacks must be installed to support the trailer when the truck goes into the trailer.

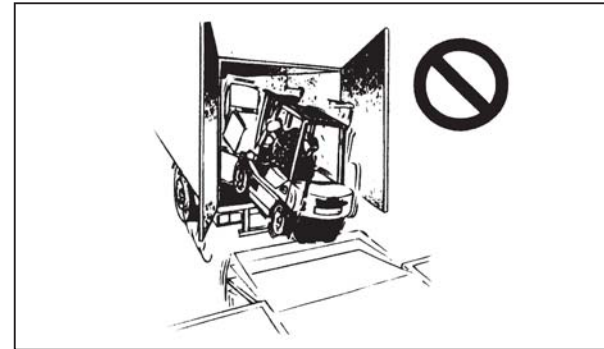

Drive carefully and slowly across the dockboard or bridgeplate. Watch for bystanders.

Give instructions to the trailer driver not to move the trailer until load handling is finished.

Make sure the dockboard or bridgeplate is secured.

⚠ Never use man as an additional counterweight

Do not use man as an additional counterweight. Do not offer rides to others.



⚠ Have a guide when handling bulky loads

When handling bulky loads which restrict your vision, operate the truck in reverse and have a guide.

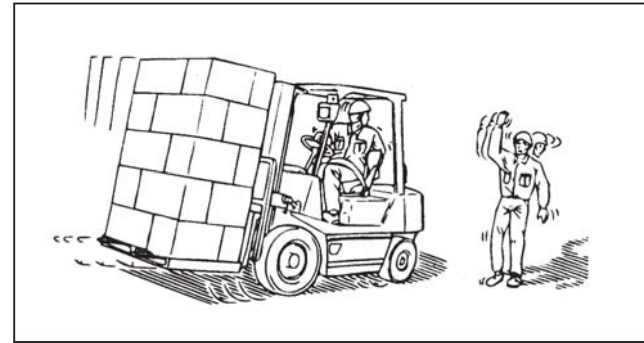

⚠ Reverse travel

When traveling in reverse, always look in the direction of travel. Do not rely too much on the sideview mirrors (if so equipped) and backup buzzer.

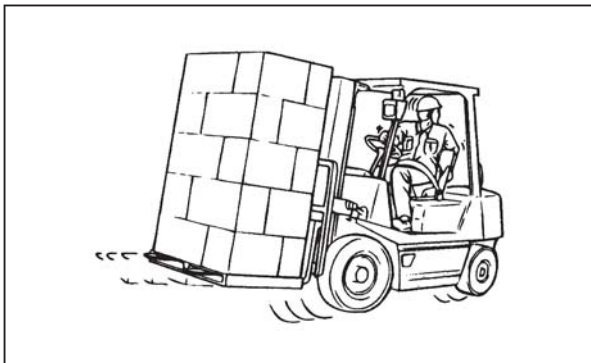

⚠ Preoperational checks

Do not start your shift until preoperational checks are finished. If any problem is found, report to your supervisor and take necessary measures.

⚠ Keep sideview mirrors, backup alarm, and lamps in good working condition

Adjust the sideview mirrors to gain a full rear vision and keep the mirrors' surface clean (if so equipped). The backup buzzer should sound when the F/R lever is placed in the reverse position. If the buzzer fails to sound, have it repaired. Make sure the lamps turn on and off properly. Burned-out bulbs must be replaced with new ones.

⚠ Keep your hands clean

It is dangerous to operate the steering wheel and levers with greasy hands. If grease, oil or soil is sticking to your hands, clean it off.

TRAVELING

⚠ Mount properly

Never mount or dismount a moving truck. When mounting or dismounting the truck, use proper procedures. Make sure the truck is at a complete stop. Support your body using the steps and hand grips properly. Keep the steps always clean.

⚠ Do not move controls unless properly seated

Do not operate the controls (levers and pedals) unless you are properly seated.

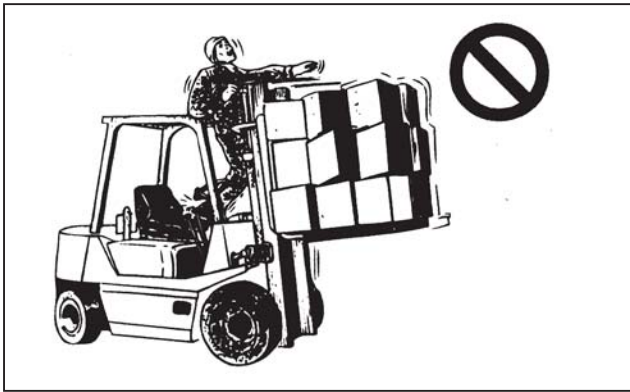

⚠ Sound horn when starting

Before starting, make sure no one is near the truck. Let other workmen and bystanders know you are starting up by sounding horn.

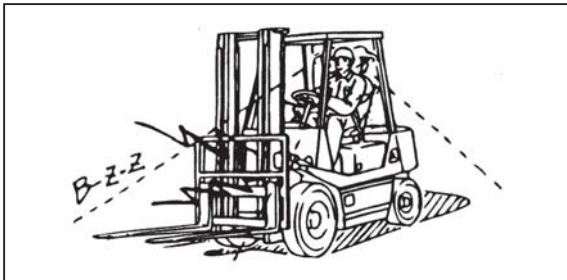

⚠ Do not turn the key switch off

If the key switch is turned off, the power steering unit goes ineffective, making it hard to steer.

⚠ Safe traveling

Always look in the direction of travel

Always look in the direction of travel; failure to do so will lead to an accident. When passing an oncoming truck each other, slow down and use caution to have a safe distance. Moreover, maintain a safe distance from the truck ahead of you at all times.

Observe speed limits

Observe the specified speed limits.

Make sure there is no one or obstacle around the truck and in the direction of travel or turning

Do not go past other trucks where vision is restricted



Do not go past other trucks at intersections, corners, narrow aisles or other locations where your vision is restricted.

Slow down at corners

Slow down and sound horn at intersections and other locations where your vision is restricted.

Come to a complete stop before crossing roads or at corners

⚠ Do not travel over a floor or ground surface covered with water

Do not travel over a floor or ground surface covered with water. Go around any pothole in the road.

⚠ Do not get into a soft ground area



⚠ Do not ride on obstacles (curb, railroad tracks, ditches)

If unavoidable, be careful.

⚠ Avoid running on a slippery surface

⚠ Know the load bearing capacity of the floor

Before entering a building or going into an elevator, make sure the floor is strong enough to withstand the weights of the truck and the loads.

⚠ When going into areas where there are limits in height and width, use the following cautions

- Make sure there is enough height and width for the truck to pass.
- Do not put your hands and feet outside the truck.
- Make sure there is no one around the truck.
- Watch out for outdoor electric cables and other obstacles.

⚠ Rear steer, rear swing

When the truck is turned in forward driving, the rear of the truck swings outwards. Before turning, make sure there is enough clearance from the wall and other obstacles.

⚠ Brake the truck in good time

The truck takes a little longer to come to a stop on a slippery surface than on a usual surface. Brake the truck in good time. In addition, the stopping distance of the truck is longer on a downhill. Keep the traveling speed under your control.

⚠ Practice safe driving and load handling techniques

Before using the lift truck, you must practice safe driving and load handling techniques. Even after getting familiar with the operation of the truck, operate the truck carefully; reckless driving and operation will cause a personal injury or an accident.

⚠ When using multiple trucks

When operating multiple trucks, remember that their operating controls have their own characteristics even if the trucks are of the same specification. If you change the trucks, keep this point in mind. In particular, pay attention to the brake system.

LOAD HANDLING

! WARNING

Never overload

Know the rated capacity of your lift truck and its attachment, if any, and never exceed it; otherwise the rear wheels will be raised, thus making it difficult to travel and turn.

There is also danger of the truck tipping over.

Never lift a load over anyone
Never permit anyone to stand under raised forks.
The forks might fall down unexpectedly, thus causing a personal injury.

Never elevate a man
Never allow other person(s) to ride on the forks. He might fall off the forks, getting injured.

Do not put your hands or feet into the load handling system
Never put your hands or feet on the mast or mast connecting members; otherwise your hands or feet might be cut if the mast moves unexpectedly.

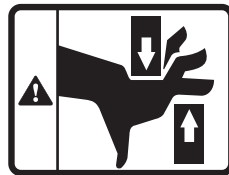
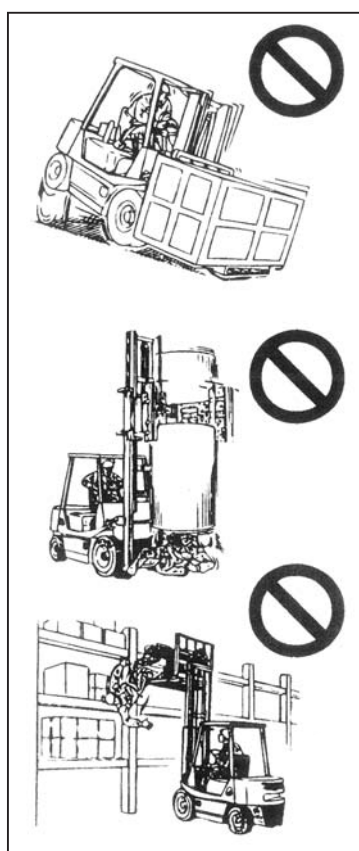

! Do not lift off-centered loads

Make sure that the loads are evenly positioned across the forks and that the load's center of gravity is aligned with the truck's center of gravity. Off-centered loads might cause the truck to turn over.

! Make loads come in contact with load backrest

Insert the forks into the pallet as far as possible to make the loads come in contact with the load backrest.

! Do not lift unstable loads

Do not handle unstable loads. When handling loose loads, make sure they are stable enough before lifting.

! Use due caution when handling loads

When handling loads, fix them with ropes or others, to prevent from falling off.

! Do not stack loads too high on forks

Do not stack loads on forks in such a way that the top of loads exceeds the load backrest height; otherwise, loads might fall to the operator side, and in the worst case lead to a serious injury or death.

⚠ Do not tilt the mast with loads high

Use minimum forward and reverse tilt when stacking and unstacking loads. Never tilt forward unless the load is over stack; otherwise the truck might tip over.



⚠ Do not lift or start with mast tilted forward

When the mast is tilted forward, do not perform the following operations: lifting the forks and starting and traveling the truck.

⚠ Do not stack or unstack loads on a sloping grade

⚠ Keep the chains tight

A slack chain means the mast tail or carriage hang-up, which might cause the sudden fall of loads or carriage or the truck to tip over. Keep the lift chains stretched tight at all time.

⚠ Do not use your truck for purposes other than specified

Do not use the truck to open or close the doors of freight cars or warehouses.

Do not push other trucks.

Do not hoist loads, using ropes hung on the forks.

Do not tow another vehicles.

Do not push or pull loads with forks; otherwise, the load might fall off or get damaged. In particular, the truck with the max. lift height of more than 150 cm might tip over, if you try to do that.

⚠ Adjust fork spacing properly

Adjust the fork spacing suitable according to the size of the load.

⚠ Adjust fork spacing with your feet

Adjust the fork spacing with your feet. Do not use your hands. Your hands might get pinched between the forks and carriage.



⚠ Make sure forks are securely locked

After adjusting the fork spacing, lock the forks with fork stoppers. Unlocked forks will slide during traveling, causing the load to fall off.

LOAD HANDLING

Keep the tension of the right and left chains even

Uneven tension of the right and left chains means uneven loads even if they are properly placed on the forks. It may also lead to broken chains.

Pay attention to the fork tips

The fork tips are sharp and could cause personal injury. In addition, if they catch on obstructions, the truck might lose control, leading to an accident.

Keep anyone but a guide away from the working area

Do not let other persons or truck approach your lift truck during operation

When working in a group, have a person present to give guidance and follow his instructions

Use pallets and skids strong enough

Pallets and skids must be strong enough to withstand the weight of loads. Use of a damaged pallet or skid might let the load fall off the forks.

Use extreme caution when handling long or bulky loads

Lift and lower the load carefully so as not to hit it against something around the truck. Keep the load as low as possible. Be careful when turning the truck, to prevent it from moving out of position or falling off.

Be alert for overhead hazards

Use caution not to let the mast or overhead guard contact overhead power cables, piping, sprinklers or overhead cross beams. If part of

the truck comes in contact with them, the load might fall off the forks or the truck tip over. Remember that the mast height becomes higher when the forks are raised.



Do not pick up loads from other truck

Do not pick up loads from raised forks of other truck. This might cause an off-centered load or the load to fall off.



Do not hold loads on the forks by hand

Do not hold loads on the forks by hand. If the truck moves unexpectedly, the load might fall off, getting the person caught under it.



Do not squeeze loads into the stack

Do not squeeze loads into the stack using the truck's traction force. This will damage the truck or loads, causing the truck to tip over.

⚠ Do not hang loads with wire ropes attached directly on the forks

Do not hang loads with wire ropes attached directly on the forks or attachment. If the wire ropes break or slide off, a personal injury might result. In particular, the use of a wire rope hung on one of the forks might cause the truck to turn over.

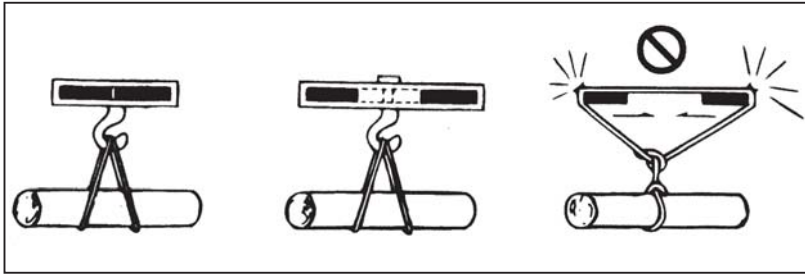

Use a hook attachment or crane arm attachment to hang loads.

Make sure that the wire ropes are strong enough to withstand the weight of the load and properly attached. The length of the ropes should be as short as possible but with adequate spread angle between legs.

Carefully travel and turn when hanging a load with wire ropes; otherwise, if the load swings, the truck might turn over. Keep the load as low as possible.



PARKING

⚠ When leaving the truck, observe the following conditions

Lower the forks on the ground at an out-of-traffic area.

Tilt the forks a little forward to make the fork tips in close contact with the ground surface.

Apply the parking brake.

Place the direction control lever in neutral.

Turn the key switch off.

Remove the key.

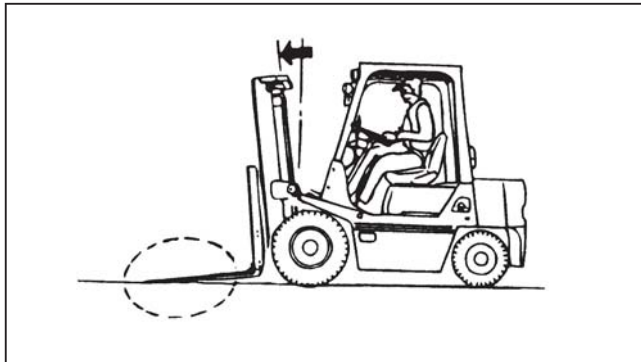

⚠ Park at the specified area

⚠ Park on a hard surface

⚠ Park at an out-of-traffic area

Park at an out-of-traffic area. Avoid parking near emergency exits, stairs, or fire hydrants.

⚠ Do not park near flammables

⚠ Block the wheels when parking on a slope

If unavoidable to park on a slope, apply the parking brake securely and block the wheels

⚠ When parking a faulty truck

When it is not possible to lower the forks on the ground due to a faulty load handling mechanism, attach a sign to the tip of the forks to prevent pedestrians and other vehicles from bumping against the forks. Park the truck at an out-of-traffic area and take measures so as not to let people pass under the raised forks.

⚠ Remove the key from a faulty truck and put up a sign

Turn the key switch off and remove the key. Attach a sign in the control area stating DO NOT OPERATE.

⚠ Do not ride on front guard

It is dangerous to use the truck body or mast as a ladder to ride on a high place.

You might be caught between the mast and truck body, resulting in a serious accident.



⚠ WARNING

Inspection and maintenance of the truck should be performed only by qualified and authorized personnel. Improper inspection, maintenance or repairs will cause

⚠ Park on a hard, level ground

Before performing inspection and maintenance, make sure to park the truck on a hard, level surface. Also make sure the place is dry and without dust.

⚠ Have a good ventilation

When performing inspection and maintenance indoors, have a good ventilation.

⚠ Have a fire prevention equipment handy

Have a fire prevention equipment handy whenever working indoors. Know how to use it.

⚠ Make sure the forks and other attachment (if any) are on the ground

⚠ Turn the key switch off

Make sure to turn the key switch off and disconnect the battery receptacle.

⚠ Unless otherwise specified, key switch must be off

Unless otherwise needed, the truck is to be parked with the key switch off, and battery receptacle disconnected.

⚠ Place all the load control levers in neutral

Make sure the accelerator lever and load control levers are in neutral.



Wipe any spilt oil or grease

Wipe any spilt oil or grease. If the truck is contaminated with oil or grease, it is difficult for you to find possible cracks or other defects.



No fire (when handling lubricants, batteries, cloth wetted with oil)

No fire. Never smoke or use fire or naked flame when handling lubricants, batteries or cloth wetted with oil.



Avoid loose fitting clothing

Wear protective clothing called for by job conditions.



Wear safety gear (hard hat, safety shoes, safety shoes, safety glasses, gloves)



Use caution not to fall down from the truck when working on the truck



Do not put your feet under the forks



Use caution not to get your fingers pinched in the floor plates or hood

Be careful so as not to get your fingers caught when closing the battery cover or doors.

INSPECTION AND SERVICE

⚠ If unavoidable to work under raised forks or attachment, use a stable support under the inner mast and/or the carriage to prevent the forks or attachment from falling down unexpectedly.

⚠ When working in a group, have a leader and follow his instructions

⚠ Use appropriate tools

Use appropriate tools suitable for the job you have been assigned. Use of inappropriate tools might cause a serious accident.

⚠ Do not use tools for purposes other than specified

Do not use tools for purposes other than specified. It can cause a serious accident.

⚠ Hydraulic oil is hot immediately after the operation of the truck is stopped

Immediately after the operation or running of the truck is stopped, the hydraulic oil is hot and in high pressure. Do not try to drain the hydraulic oil or replace the filter. Hot oil might spout out to cause burns.

⚠ Release oil pressure before working

The hydraulic circuit has residual pressure. Before working on the system, release the pressure. To check for oil leaks, wear safety glasses and gloves and use a piece of cardboard or wood. High pressure oil penetrates the skin. It can cause blindness.

⚠ Checking of accumulator and piping is hazardous

Inspection of piping where an accumulator is installed is hazardous. When it needs to be inspected, ask your TEU dealer.

⚠ When high pressure oil comes in contact with your body, immediately get medical attention.

⚠ Remove the battery receptacles before working on rotating parts

Use due caution when working on rotating parts, not to get your body entangled in them. Before checking a rotating part, make sure to turn the key switch off and disconnect the battery receptacles. Do not bring something near rotating parts.



⚠ Do not use the mast as a ladder

When carrying out checks or adjustment, do not use the connection member or load backrest as a ladder. The mast might move unexpectedly, pinching or cutting your hands or feet.

Do not use the mast as a ladder. You might fall down from the mast, leading to a serious accident.

Caution to be taken when adjusting tire inflation pressure (rim, compressor)

When checking tire inflation pressure, position yourself in the path of rotation, not on the side of the tire.

When inflating a tire using a compressor, first adjust the air pressure of the compressor; otherwise the air pressure will rise to the maximum pressure of the compressor, leading to a serious accident.

Inflating tires to a high pressure requires special skill. Inflating tires requires special skill. Tires must be inflated only by a qualified person

When using compressed air, wear safety glasses and mask. When inflating tires, wear safety glasses and mask because dust might get into your eyes or mouth.

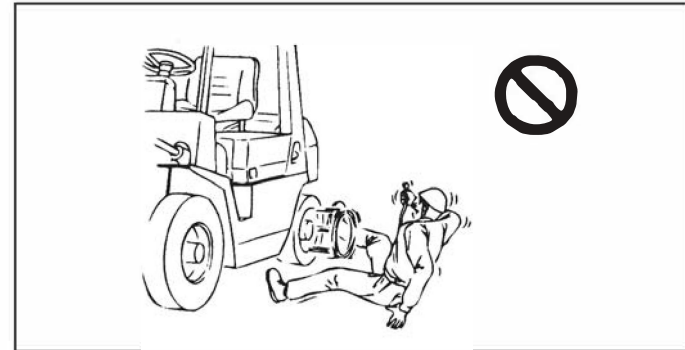

Leave the disassembly and reassembly of tires, tubes and rims to a specialist

The inflation pressure of tires of the lift truck is very high (about 700 to 1000 kPa) and thus due caution must be required to disassemble or reassemble the tires. An improperly reassembled tire might cause explosion to let parts fly into pieces, resulting in a serious personal injury.

INSPECTION AND SERVICE

⚠ Do not loosen the wheel assembly nuts when changing a tire

The wheel assembly is locked in two ways: Hub nut type and nut type. In the hub nut type wheel assembly, the wheel is installed to the hub; in the nut type, a wedge ring is inserted between the wheel and the hub to lock the wheel assembly.

The tire is secured with the side ring and the lock ring.

When removing a tire from the truck, make sure the lock ring is securely installed; otherwise, the side ring, tire, and wedge ring might burst out, resulting in a severe accident.

⚠ Do not loosen bolts and nuts of split rim assembly

The wheel has hub nuts that secure the wheel to the hub and rim nuts and bolts that assemble two rims together. When removing a tire from the truck, do not loosen the bolts and nuts of the split rim assembly.

If the bolts and nuts of the split rim assembly are removed, the rims, bolts or nuts might blow off due to the internal pressure of the tire, bolts or nuts might blow off due to the internal pressure of the tire, to cause a serious personal injury.

When replacing the rim assembly, install a new rim assembly with the head of each of the dowel bolts of the rim assembly pointing outside. (This helps make it difficult to loosen the rim bolts with the tire attached to the truck. Some bolts have a special shape for this purpose.)

After replacing tires, test run the truck to check to see if the hub nuts are securely tightened. If a loose hub nut is found, tighten it to the specified torque.

⚠ WARNING

Cautions to be taken when using the jack

Do not enter under the truck while it is jacked up. The truck might fall, getting you caught under it.

Before jacking up the truck, remove the loads from the truck.

When jacking up the truck, the operator must leave the truck.

Lift the truck a little off the ground surface and put supports at both sides of the frame to prevent the truck from falling.

Before jacking up, block the wheels to prevent them from rotating unexpectedly.

Lifting the truck must be performed only by qualified personnel (for crane or slinging work).

The truck must be lifted by attaching wire ropes to the designated parts.

Use strong wire ropes

Make sure the wire ropes are strong enough to lift the truck

INSPECTION AND SERVICE

Obey regulations

When disposing of waste oil, solvent, or discharged battery, obey the regulations and rules.

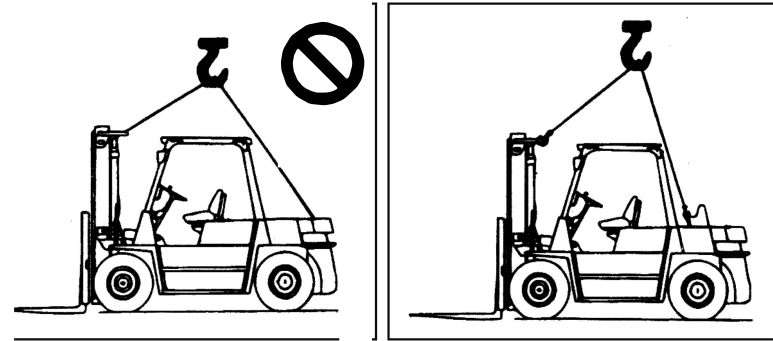

WARNING

Never hoist your lift truck by attaching ropes or wires to its overhead guard or counterweight; otherwise there is the possibility of the chassis getting damage or falling. If hoisting the lift truck is necessary for any reason such as transportation, use an optional "Chassis Lifting Eye". For the Chassis Lifting Eye, consult your TEU dealer.

CAUTION PLATES

The caution plates attached to the lift truck explain cautions to be taken when using the truck, and procedures for operating the truck. Read messages on the caution plates as well as the description in this manual. Damaged or missing decals must be replaced with new ones.

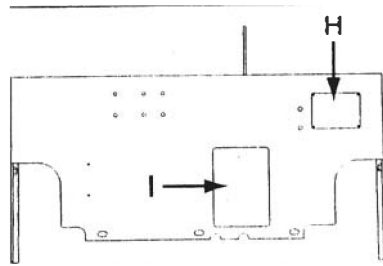

View looking from ①

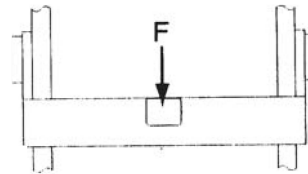

View looking from ⑤

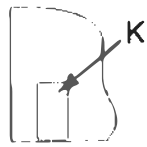

View looking from ②



View looking from ③

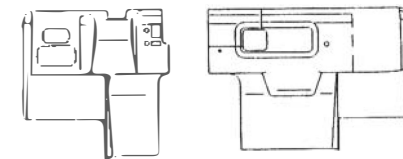
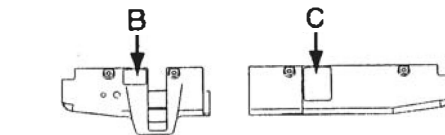
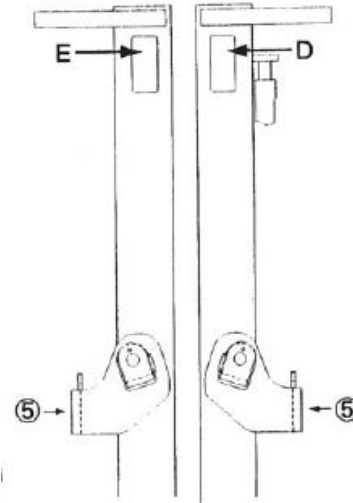
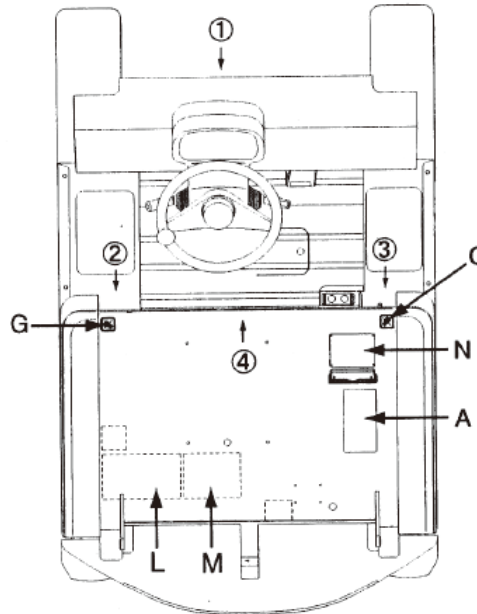

View looking from ④

B: Parking brake lever adjustment

I : List of lubricating locations

L: Battery charger handling

M: Battery handling

H. Name plate

J. Tire inflation pressure (example)

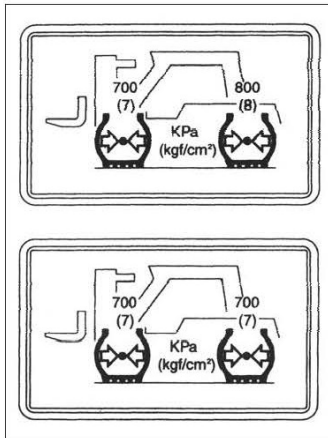

K. Warning decal for handling inflated tires



N. Load chart: Do not overload!
(For load charts, see page 5-4.)

! CAUTION

The instructions on the caution plates carried in this manual may differ from those on the caution plates attached to the truck body. In such a case, observe the instructions on the caution plates

CAUTION PLATES

A. Safe operation

WARNING

YOU MUST FOLLOW THESE RULES TO AVOID SEVERE INJURY OR DEATH TO YOURSELF AND OTHERS.

1. Operate truck only if trained and authorized by your employer. Know Operation & Maintenance Manual and all work rules.
2. Safety check truck every day. Do not start if damaged or faulty; stop if problems start. Repair allowed only by trained, authorized mechanics.
3. Turn, start, stop, and handle loads smoothly and slowly.
Carry loads low and lifted back; stack only on level using minimum tilt.
4. Look where you are going. Watch out for people, hazards on floors and overhead, drop-offs and tail swing clearance.
5. Truck overturn can kill you. Slow for turns even when empty. Never turn on inclines.
6. Do not lift overweight or loose loads. Move slowly with wide, high, or long loads. Keep forks wide and fully under loads. Travel in reverse if loads block view. Attachments require special training, ask your employer.
7. Keep loads upgrade on all inclines. Stay clear of ramp and dock edges. Make sure dockboards and trailers are secure before going on them.
8. Overhead guard and load backrest must be on truck. Always keep yourself completely inside guard.
9. Stop engine when refueling. Follow Operation & Maintenance Manual and employer's work rules about fuel, battery and tire maintenance hazards.
10. Forks can fall rapidly even with light loads. Do not raise people or allow them under forks. No passengers allowed on truck.
11. Park only in authorized areas, never on inclines. Lower forks to bottom, put direction control in neutral, turn off key and make sure parking brake is set.
12. Fasten the seat belt, when operating the lift truck.

C. Warning for front guard



F. Warning for mast connecting members

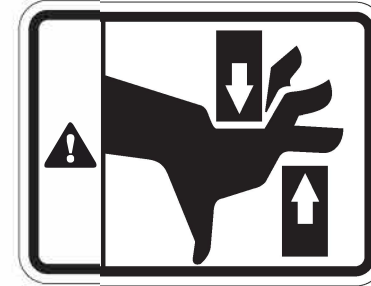







D,E. Warning for load handling means



G. Entanglement



■ Caution plate for handling batteries

						
No fire	Wear safety glasses	Keep children away	Sulfuric acid	Read manual	Explosive	Electric shock





! DANGER

Handle the battery carefully; otherwise you will get injured.
 Pay attention to an open flame or static electricity which might cause an explosion or a fire.
 Sulfuric acid will cause painful and serious burns if it gets on the skin. It can cause blindness if it gets into eyes.
 Touching a conducting part with bare hands will cause an electric shock accident.
 Do not connect or disconnect the battery plugs with the battery turned ON; otherwise you might get burnt or an explosion might occur.

No fire. Do not smoke. Keep sparks or flames away from batteries.
 Static electricity: Do not clean batteries with a duster or dry cloth.
 Ventilation: Get a good ventilation. Do not use or charge batteries in a closed place or an area where ventilation is poor.
 Sulfuric acid: If sulfuric acid comes in contact with your skin or clothing, wash it away using a copious amount of water immediately. If sulfuric acid gets into your eyes, wash your eyes with a copious amount of water immediately and get to a doctor.
 Electrolyte level: Keep the battery electrolyte level proper at all times. If the level is too low, the battery will build up heat; if the level is too high, electric leakage will occur.
 Electric shock accident: Wear safety glasses, rubber gloves, and shoes with rubber soles when servicing or inspecting batteries.

The following symbols, found throughout this manual, alert you to potentially hazardous conditions to the owner and the operator. Become completely familiar with the truck before proceeding with operating, checking and servicing.

This manual and decal affixed to the truck use the following safety alert indications.

SIGNAL WORD	CLASSIFICATION
 DANGER	Failure to follow the instructions in the message will likely cause a serious accident or death.
 WARNING	Failure to follow the instructions in the message might cause a serious accident or death.
 CAUTION	Failure to follow the instructions in the message may cause personal injury or damage to the truck or other property.
 NOTE	The information will help to prolong the service life of the truck. The message is not directly related to accident prevention.

2.OPERATING CONTROLS

CONTENTS

PICTORIAL NOMENCLATURE.....	2 - 1
INSTRUMENTS AND CONTROLS.....	2 - 2
METER INSTRUMENT	
MANUAL.....	2 - 14
DRIVING AND HYDRAULIC INTEGRATED	
POWER SYSTEM.....	2 - 24

PICTORIAL NOMENCLATURE

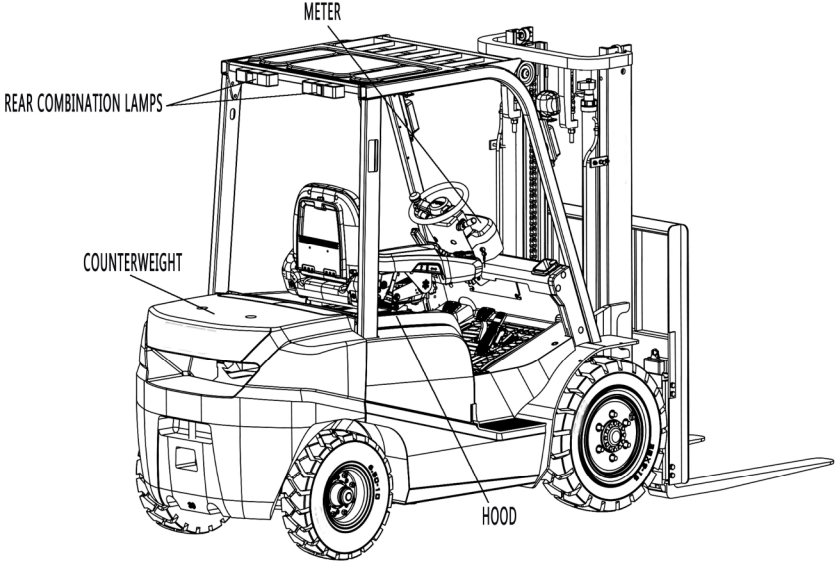
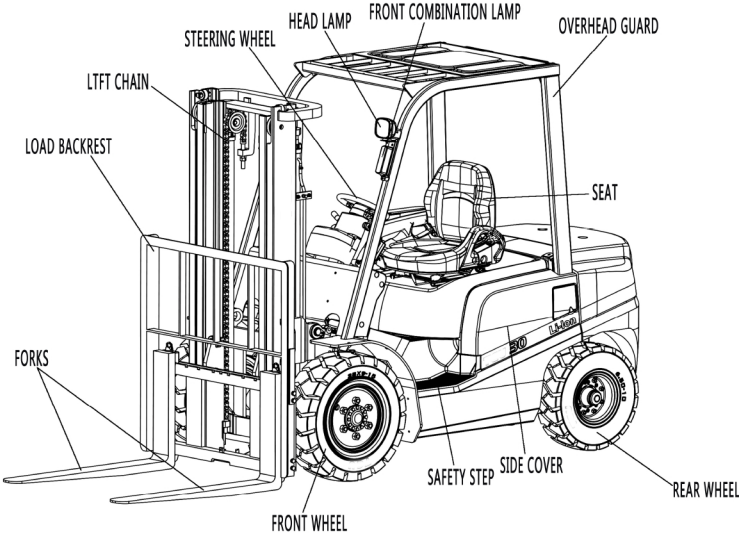

INSTRUMENTS AND CONTROLS

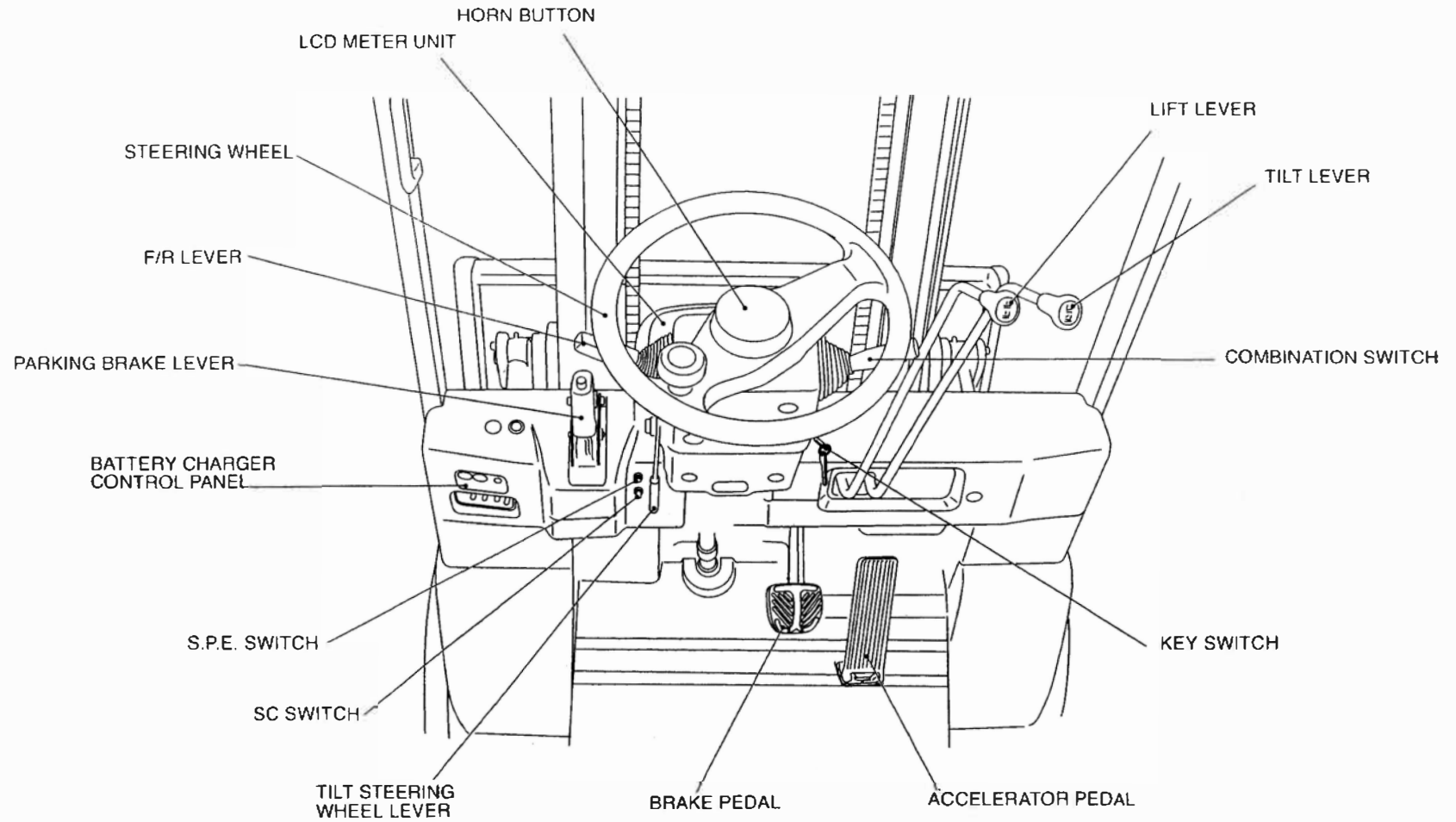

SWITCHES

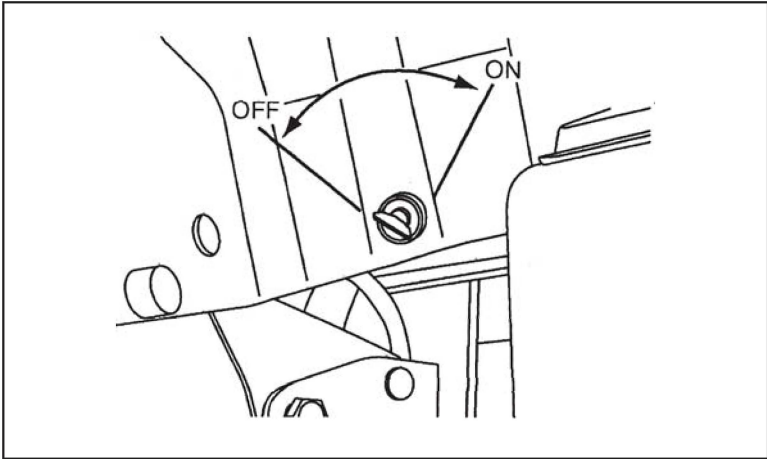

Operation Device and Method of Usage

REGENERATIVE BRAKING

- The driving direction of the vehicle is same as that of gear lever. (For example: When the vehicle moves forward, the gear lever is in “D” position)
- Release the accelerator pedal and put on the brake pedal.
- During regenerative braking, the foot leaves the brake pedal. Hit the accelerator pedal, and then release when the driving speed is close to 0km/h.

KEY SWITCH

⚠ CAUTION

Disconnect the battery receptacle before working on the electric components. The electric circuit is live even if the key switch is turned OFF.

Before leaving the truck, make sure the key switch is turned off and remove the key.

OFF.....The key switch is OFF. Key insertion and draw-out position.

ON.....The electric circuit is closed. After 1 second of self-check, the truck becomes ready for operation. The power indicator lights up.

🔑 NOTE

If the following operation is carried out, the safety circuit of the truck is activated. In this state, the truck won't start. If you want to start the truck, release the safety circuit.

The F/R (Forward/Reverse) lever is operated with the key switch OFF. (That is, the key switch is turned on with the forward/reverse lever in positions other than neutral.)

- Resetting the safety circuit-
Place the F/R lever in neutral and turn the key switch OFF and then ON.

INSTRUMENTS AND CONTROLS

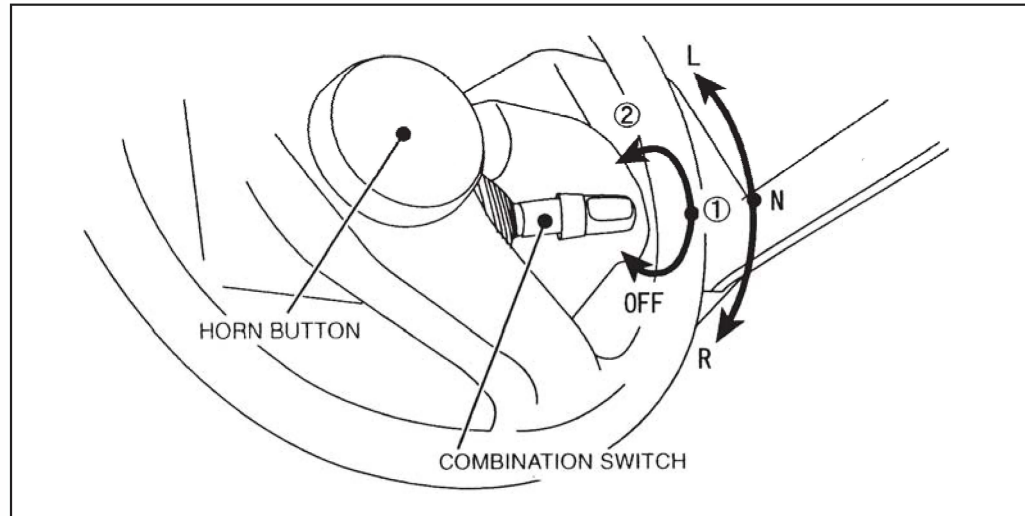

COMBINATION SWITCH (LIGHTING)

This light switch can be rotated in 2 steps.

Stage	OFF	①	②
Light	OFF	①	②
Clearance light	OFF	ON	ON
Tail light	OFF	ON	ON
Head light	OFF	OFF	ON

NOTE

The above lights turn on or off regardless of the position of the key switch. Remember to turn them off when leaving the truck.

(TURN SIGNAL)

Use the turn signals (front and rear) to indicate the traveling direction of the truck.

L	Left lights turn on.
N	OFF
R	Right lights turn on.

NOTE

The turn signal lever automatically returns to neutral when the steering wheel is returned to the straight position.

The turn signal lever may be optionally located at the right side of the steering column.

HORN BUTTON

Press the horn button at the center of the steering wheel to sound the horn. The horn sounds regardless of the key switch position.

LEVERS AND PEDALS

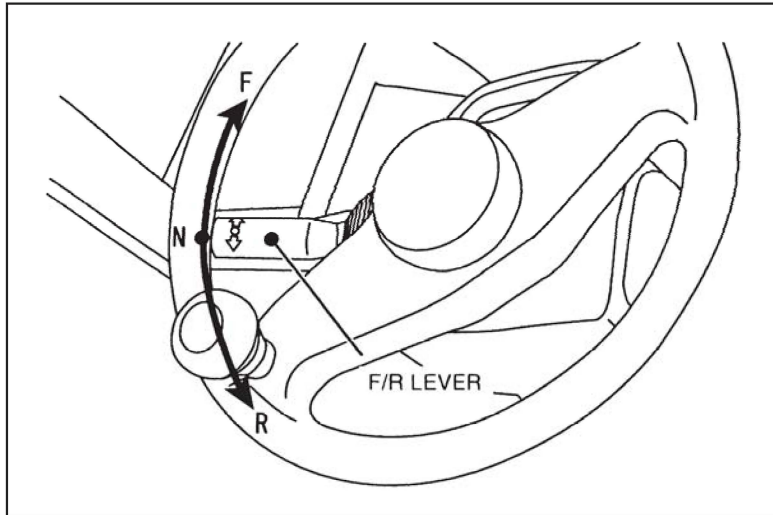

F/R LEVER

Use this lever to select the traveling direction of the truck.

F	Forward
N	Neutral (Ⓝ appears on the display.)
R	Reverse (The back-up light comes on and the back-up buzzer sounds.)

■ **Regeneration (switch-back regeneration)**

This truck is equipped with regenerative brake system. The regenerative brake system automatically returns electric energy created by braking to the batteries for better use of energy.

It operates when the following conditions are met:

- The accelerator pedal is stepped on.
- The F/R lever is reversed while traveling.

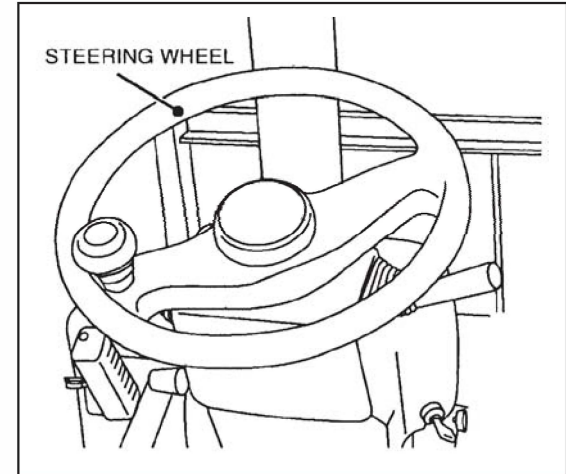

Steering wheel

⚠ CAUTION

Do not turn the key switch OFF while traveling. When the key switch is turned OFF, steering operation becomes hard.

When traveling the truck, hold the steering wheel knob with your left hand. Do not remove your hand from the knob while traveling. The truck comes with poser steering to provide smooth, light steering with the key switch on.

INSTRUMENTS AND CONTROLS

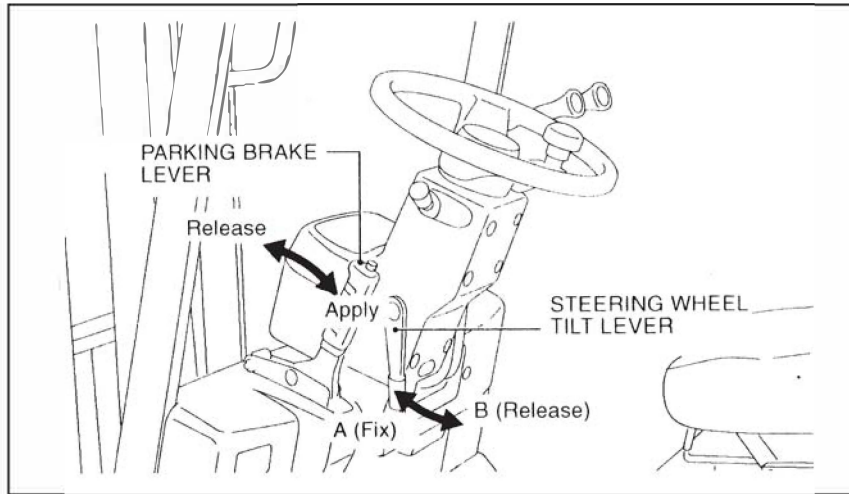

PARKING BRAKE LEVER

⚠ CAUTION

When parking on a grade, be sure to block the wheels.

Before pulling the parking brake lever, step on the brake pedal.

Use the parking brakes to park the truck. Pulling the lever toward you applies the brakes to the two front wheels. The indicator (**(P)**) lights up on the LCD. To release the parking brakes, push the parking brake lever forward.

TILT STEERING WHEEL LEVER

⚠ CAUTION

Set the steering column at the most comfortable position before trying to start the truck.

After adjusting the steering column position, turn the lever in the direction of "A" to lock the steering column.

Never try to adjust the steering

The steering wheel column can be tilted forward and backward according to the operator's physique. Turn the lever in the direction of "B" to loosen the steering wheel column. After adjustment, turn the lever to "A" to lock.

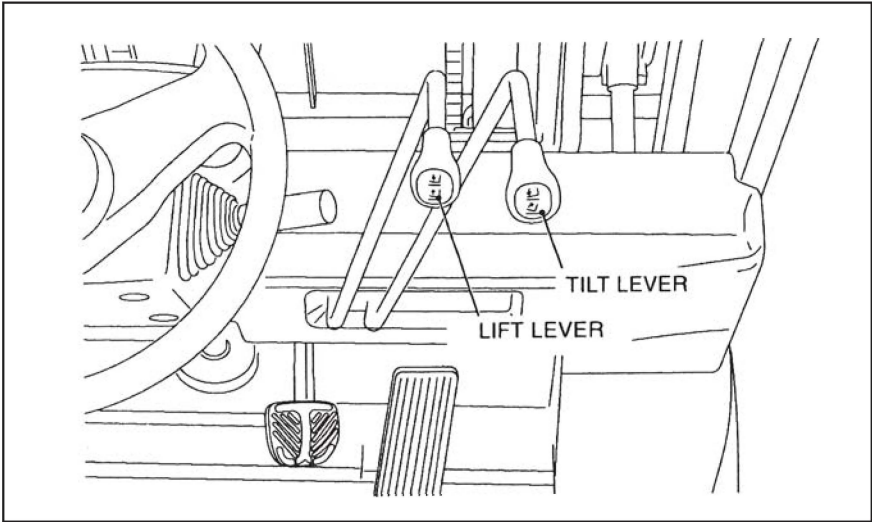

LIFT LEVER

⚠ CAUTION
Seat yourself in the operators seat and make sure there is no one around the truck before trying to operate the lift lever.

Pulling back the lever will raise the forks and pushing forward it will lower the forks. The lifting speed of the forks can be controlled by the tilt angle of the lever.

TILT LEVER

⚠ CAUTION
Seat yourself in the operators seat and make sure there is no one around the truck before trying to operate the tilt lever.

Pulling the tilt lever will tilt backward the mast and pushing forward it will tilt the mast forward. The tilting speed of the mast can be controlled by the tilt angle of the tilt lever.

📖 NOTE
If the tilt lever is operated with the key switch OFF, the mast won't tilt forward due to the operation of the tilt-lock mechanism incorporated in the control valve. This is not the malfunction of the system.

INSTRUMENTS AND CONTROLS

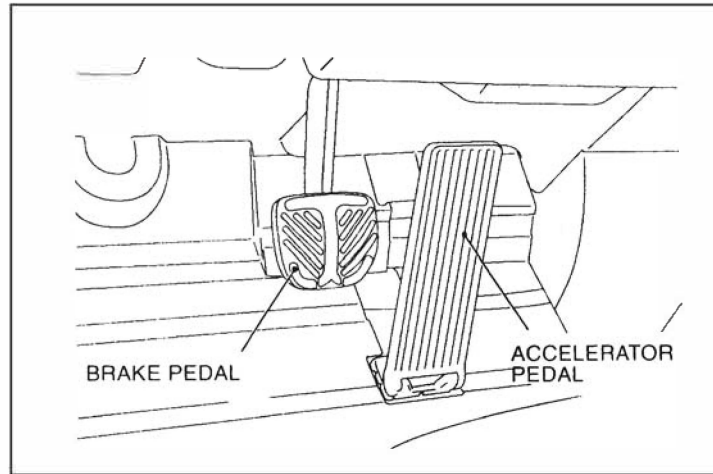

PEDALS

The truck has 2 foot controls: brake pedal and accelerator pedal (from the left).

BRAKE PEDAL

Step on the brake pedal to slow down the truck. Brake lamps light up when the brake pedal is pressed.

Before stepping on the brake pedal, release the accelerator pedal first.

ACCELERATOR PEDAL

The accelerator pedal controls the traveling speed of the truck.

Turn the key switch ON and shift the F/R lever into forward or reverse, and step on the accelerator pedal. The traveling speed is indicated on the display.

CAUTION

Brake switch

Do not remove the brake switch.

When the brake pedal is stepped on, the brake switch operates to turn the brake lamp on and activates brake regeneration.

TRUCK BODY

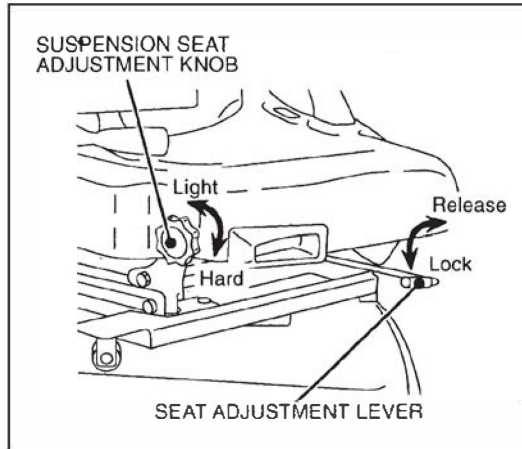

DRIVER'S SEAT SUSPENSION

⚠ CAUTION

Adjust the suspension of the driver's seat using the adjustment knob before starting the day's work or each shift. Do not try to adjust the suspension during operation.

Adjust the driver's seat suspension properly to suit the individual operator's physique and to provide best comfort. Turn the adjustment knob to the value of your weight. The seat absorbs shock and vibration to provide comfort during traveling and operation.

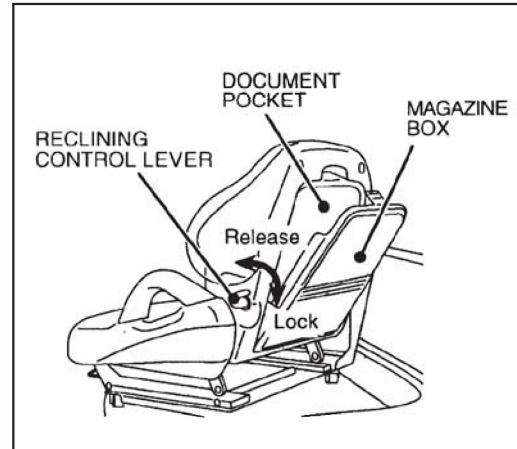

SEAT ADJUSTMENT LEVER RECLINING CONTROL LEVER

⚠ CAUTION

Adjust the seat position before starting your day's work or each shift. Make sure the seat is securely locked.

Adjust the driver's seat to a position to suit the individual operator's physique. To unlock, pull up the lever. After adjustment, try to move the seat back and forth to make sure that the seat is securely locked.

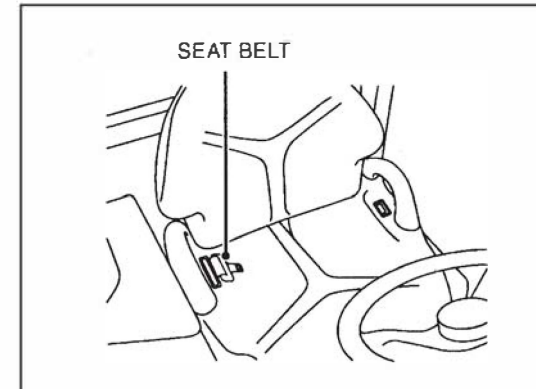

DOCUMENTS POCKET AND MAGAZINE BOX

The driver's seat has a document pocket and magazine box at its back. Use them for storing the Instruction manual and others. Remember to close the document pocket before operation.

SEAT BELT

⚠ WARNING

Be sure to fasten the seat belt before starting traveling or operator might be thrown out and, in the worst case, the operator can be crushed by the truck causing severe injury or even death.

Pull out the connector at the right side and insert it into the receptacle at the left side until it clicks. To unfasten the seat belt, press the red button by the receptacle, and the belt automatically winds up into the

INSTRUMENTS AND CONTROLS

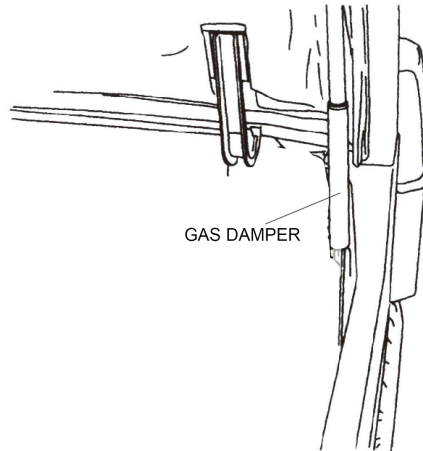

HOOD STOPPER

⚠ CAUTION

After opening the hood, make sure gas damper stopper is engaged.

Use caution not to get your fingers caught in the hood when closing it.

The hood has a stopper at the middle of the gas damper. After opening the hood, make sure the gas damper stopper is securely engaged. When closing the hood, hold the hood and push the gas damper stopper to bring the hood down slowly.

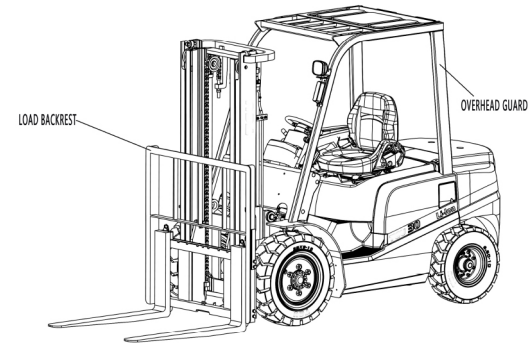

OVERHEAD GUARD

⚠ WARNING

The overhead guard is an important safety device which protects the operator from falling objects. Make sure it is securely installed. Do not use the truck with the overhead guard removed or modified; otherwise it might cause

👉 NOTE

Keep the vinyl rain gutter always clear of dust.

LOAD BACKREST

⚠ CAUTION

The load backrest is an important safety device which protects the operator from a falling load if the forks disengage from the carriage. Make sure the load backrest is securely installed. Do not use the truck with the load backrest removed or modified; otherwise it might cause

INSTRUMENTS AND CONTROLS

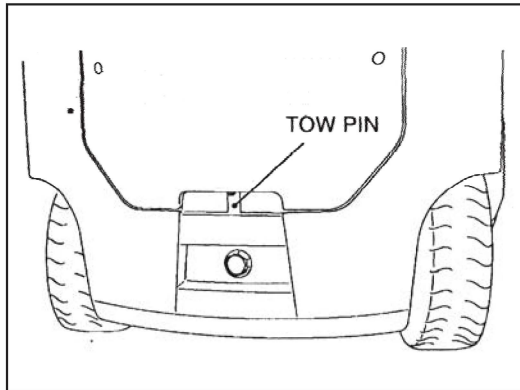

TOW PIN

⚠ CAUTION

Do not use the tow pin for towing another vehicle or for being towed by another vehicle.

Use the tow pin for the following cases:

When the truck has bogged down in the mud or a side ditch.

When loading onto or unloading from a trailer for transportation.

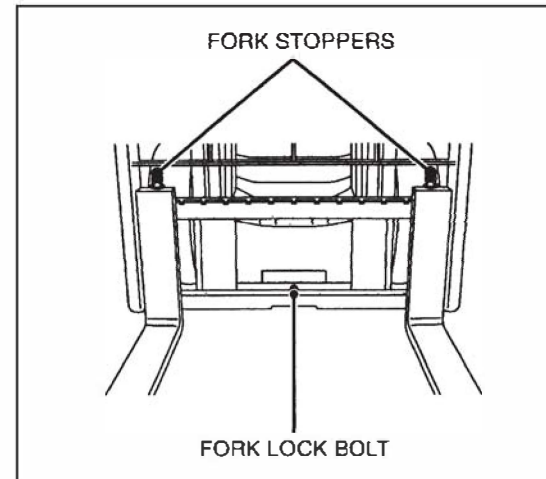

FORK STOPPER

⚠ CAUTION

The forks should be set symmetrically to the truck centerline, and fork stoppers should always be set.

When adjusting fork spacing, hold the load backrest and push the forks

Secure the forks with the fork stoppers. Pull up the fork stoppers a little and turn 90°.

Then adjust the fork spacing using your foot according to the size of the load you

FORK LOCK BOLT

⚠ CAUTION

Do not remove the fork lock bolt other than the following cases; otherwise the forks might disengage from the carriage, causing personal injury.

When removal of the forks is needed.

When gathering the right and left forks together to the center

When a fork prong is moved to the center, it will come off the carriage. This bolt prevents the fork from being used at the

INSTRUMENTS AND CONTROLS

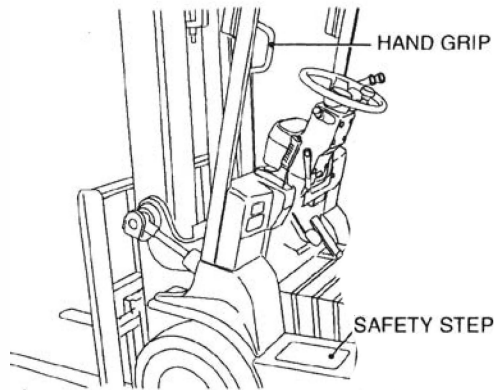

SAFETY STEP AND HAND GRIP

⚠ CAUTION

Use the safety step and hand grip when mounting and dismounting. Do not hold the steering wheel when getting on or off. Do not mount or dismount while the truck is in motion.

The truck is equipped with a safety step at front left side of the body and a hand grip on one of the front poles of the overhead guard. When mounting or dismounting, use the safety step and hand grip.

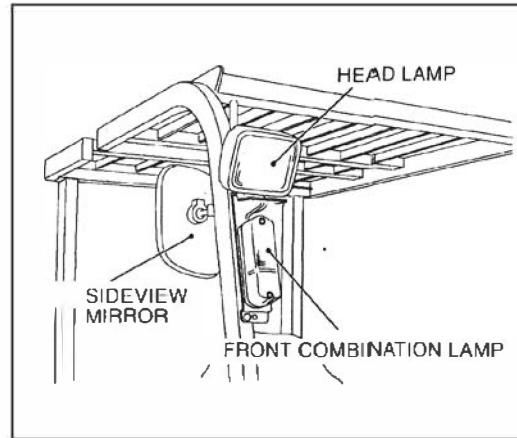

LIGHT AND LAMPS

⚠ CAUTION

Check that lights and lamps come on and off properly. If any light bulb is blown out, replace with a new one. If the lens is contaminated or damaged, clean or repair.

Front side

The truck has head lamps and front combination lamps (turn signals and clearance lamps) at its front side.

Rear side

The truck has rear combination lamps (tail lamps, brake lamps, back-up lamps, turn

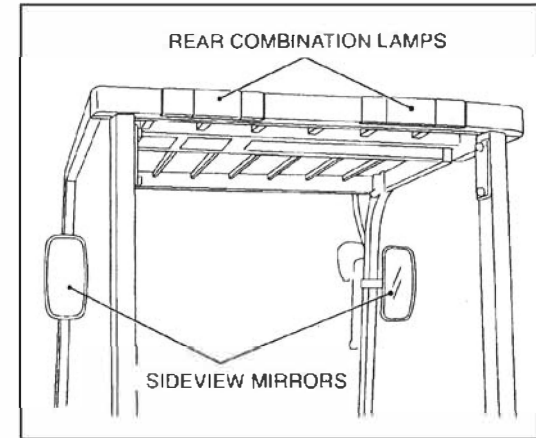

SIDEVIEW MIRRORS

⚠ CAUTION

When traveling in reverse, always look in the direction of travel. Do not rely too much on the sideview mirrors.

Keep the mirror surfaces always clean.

Adjust the sideview mirrors to gain full rear vision.

The sideview mirrors are provided on the front poles of the overhead guard, one for each.

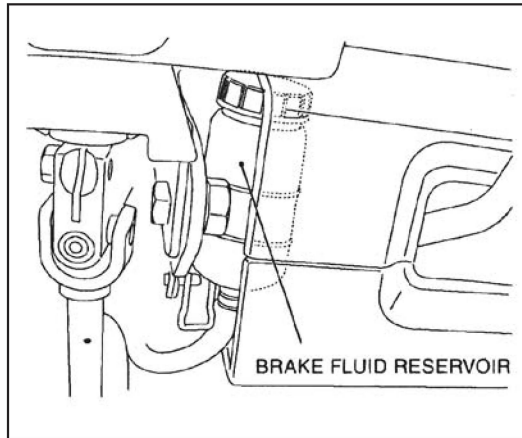

BRAKE FLUID RESERVOIR

The brake fluid reservoir is located under the front guard at the right side of the steering column. The operator can check the brake fluid level from outside.

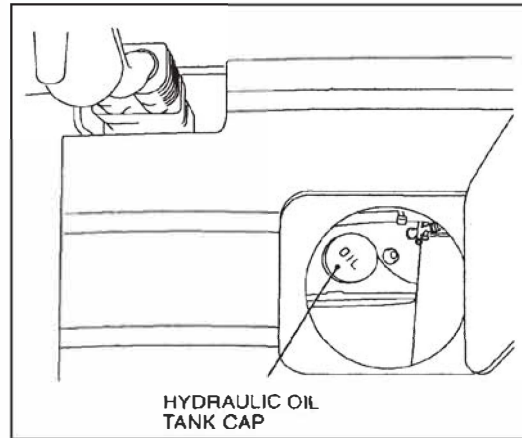

HYDRAULIC OIL TANK CAP

The hydraulic oil tank cap is located under the floor mat. The tank cap is fitted with an oil dipstick for easy level checking.

Overview

T43G-A series electric forklift instrument uses a 4.3-inch full dot matrix color liquid crystal display (LCD) to display vehicle information. The instrument is powered by 12V and communicates with all parts of the vehicle through CAN bus to obtain the current vehicle state and display it in real time.

Electrical Parameters

1. Screen specification: Screen size 4.3 inches, resolution 800*480, 16.7M colors, LED backlight;
2. Input voltage: Nominal voltage 12V, input voltage range 6~15V;
3. Input current: Normal working current 350mA, maximum input current 600mA;
4. Protection grade: IP65 for front protection grade, and IP40 for back protection grade;
5. Storage temperature: -30℃~85℃;
6. Operating temperature: -20℃~70℃;
7. Working humidity: 10% RH ~ 95% RH;









Main Interface and Icon Description

The main interface is as follows, and uses the three-segment design, i.e., left, middle and right, where the left segment displays the current vehicle speed, the right segment displays the current state of charge (SOC), and the middle segment displays the current forward direction, vehicle speed mode and fuel pump system mode.



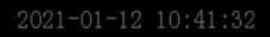





No.	Display Content	Display Mode	Remarks
1	Speed Display		Digital display
			Icon display; the icon turns green when the vehicle speed is less than 20 Km/h, and turns red when the vehicle speed is higher than 20 Km/h;
2	Battery Level		Digital display
			Icon display; the icon turns red when the SOC is lower than 15%, and turns green when the SOC is more than 15%;

METER INSTRUMENT MANUAL

No.	Display Content	Display Mode	Remarks
3	Gear Information		Indicating Drive Gear;
			Indicating Parking Gear;
			
4	Speed Mode Display		“Regular Mode”, which can be changed via the button.
			“High Speed Mode”, which can be changed via the button.
5	Clock		Display the current date and time, and the time can be changed via the menu;
6	Cumulative duration		Start timing after powering on, and end timing after powering off; the funnel icon flashes once per second;
7	Main Contactor State		When the main contactor is closed, “READY” is displayed, and the vehicle is in a normal standby state; when there is no such icon, it means that the vehicle is not normally powered on;
8	Manual Brake		Display when manual brake is closed.
9	Seat Switch		When the driver does not sit on the seat, this icon is displayed; when the driver operates normally, this icon disappears;

METER INSTRUMENT MANUAL

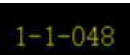
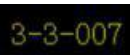
No.	Display Content	Display Mode	Remarks
10	Fault Warning Icons		The power battery voltage is too low or too high.
			The power battery temperature is too low or too high.
			Failure of the vehicle insulation
			Motor overheated
11	Foot Brake Display		Display when the brake pedal is depressed
12	Low Battery Warning		This icon lights up when the SOC is lower than 5%.
13	Fault Icon		This icon lights up when there is a fault.
14	Fault Code		The Fault code consists of 3 parts: X-Y-ZZZ X: Equipment code, 1 stands for BMS, 2 for VCU, 3 for driving controller, and 4 for fuel pump controller; Y: Fault level, totaling 3 levels; ZZZ: Fault code.
			

METER INSTRUMENT MANUAL

Outside Drawings and Dimensions

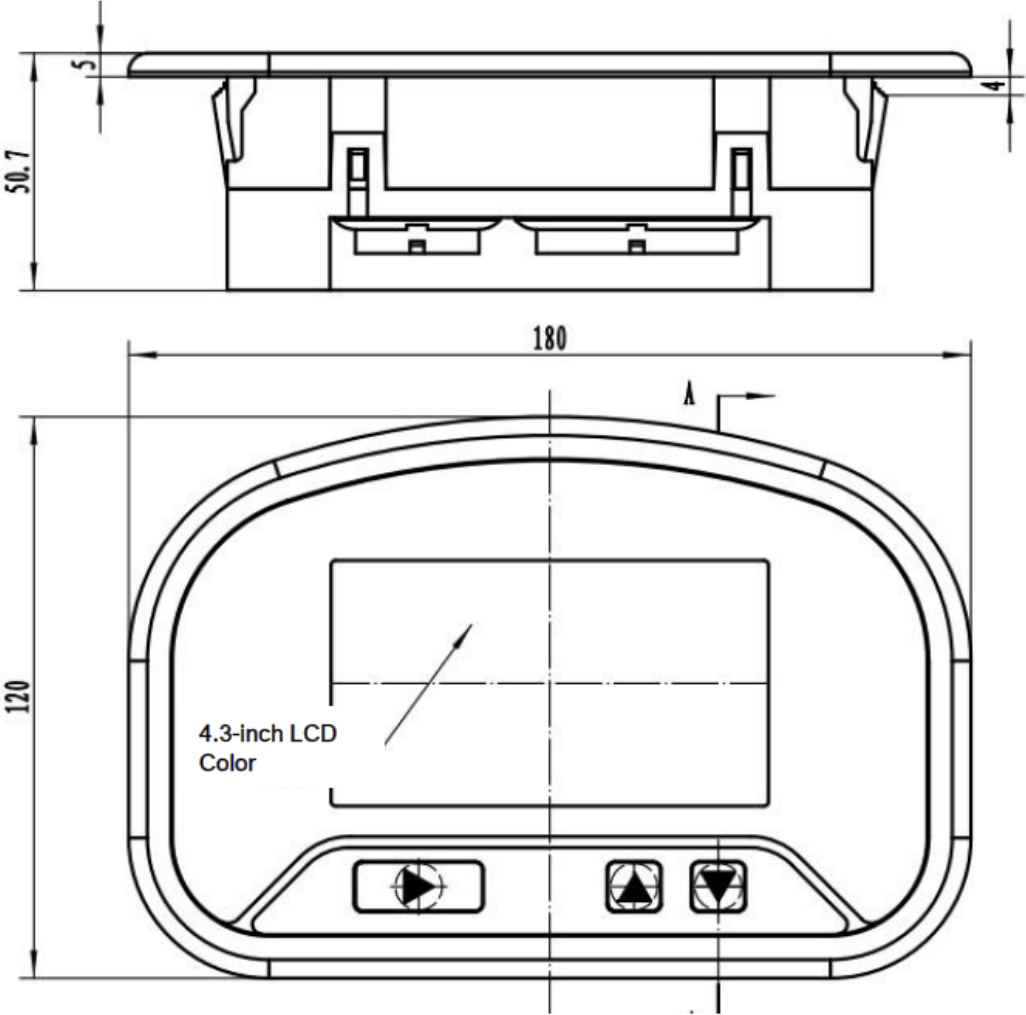

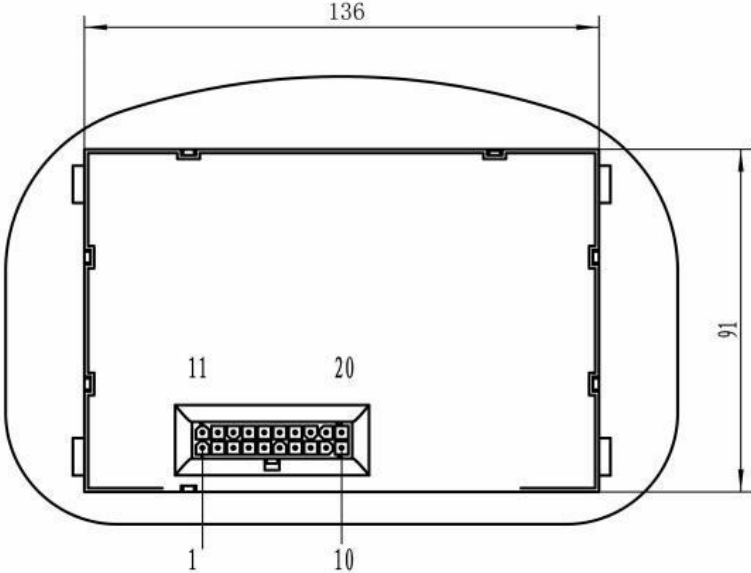

Definition of Connector

Instrument side of 20-pin connector (rear view)

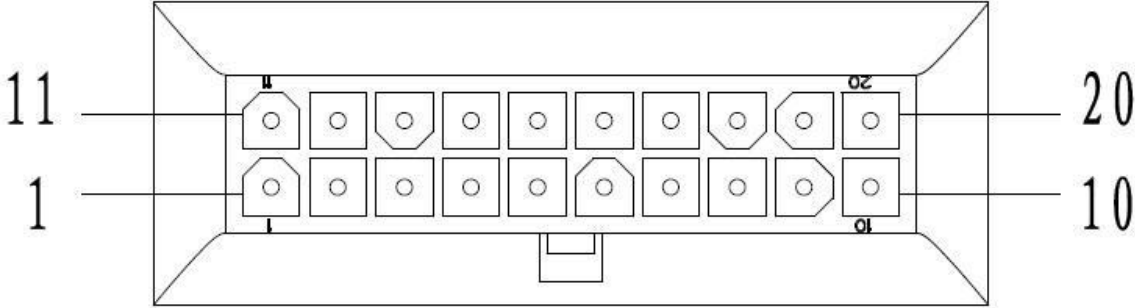







METER INSTRUMENT MANUAL

Pin No.	Pin Definition	Pin No.	Pin Definition
1		11	Power Supply 12V+
2	Ground Wire of Power Supply 12VGND	12	
3	CANH	13	CANL
4		14	Key Switch (Wake-up Signal) 12V+
5		15	
6	Ground Wire of Power Supply 12VGND	16	
7		17	
8		18	
9		19	
10		20	

Function Description

Key Description

- 1.OK Key  : Click to enter the next menu, referred to as “OK Key”.
- 2.UP Key  : This key is to select the previous menu and to increase the number in a menu, and is to select the speed mode and to select the hydraulic mode at a main interface, referred to as “UP Key”.
3. DN Key  : This key is to select the next menu and to reduce the number in a menu, and is to select the speed mode and to select the hydraulic mode at a main interface, referred to as “DN Key”.
4. Back Key  : In a menu, press and hold OK Key for more than 1s, then release to return to the previous menu, referred to as “Back Key”;
5. Combination Key  +  : Press and hold OK Key and DN Key at the same time for more than 5s to enter the menu interface;

Switching “Speed Mode” Function

Use the UP Key or DN Key to switch the speed modes, and meanwhile the corresponding icons will be displayed on the instrument panel. See technical data for the corresponding vehicle parameters of a speed mode.

Switching “Hydraulic Mode” Function (Optional)

Use the UP Key  to switch the hydraulic modes, and meanwhile the corresponding icons will be displayed on the instrument panel. See technical data for the corresponding vehicle parameters of a hydraulic mode.

Menu Function

Use the Combination Key to enter the menu interface, select the desired submenu with UP Key and DN Key, and enter with OK Key.



“Vehicle Information”

With the vehicle information, the current vehicle state and the parameters of each component can be viewed, and the current vehicle condition can be known.

“Part Test”

Through this submenu, the water pump and fan can be turned on separately to test whether they can work normally. This function is invalid when the vehicle is in “Drive Gear” or “Reverse Gear”. Please use this function under the guidance of technicians, to avoid vehicle damage.

“Fault Query”

The current fault information and the corresponding specific information of a fault code can be viewed in this submenu.

“System Settings”

This sub-menu includes four functions: “Language Selection”, which is not yet developed; “Factory Settings”, which is provided to the car factory to set the instrument information when a car is delivered from the factory, and operation details can be found in <Guide Book for Instrument Factory Settings >; “Date Correction”, which is to set the time and date displayed by the current instrument; and “Version Information”, which is to display the software version information of the main components of the current vehicle.

CAN Communication Function

The instrument communicates with the vehicle equipment through the CAN bus and displays the relevant information. The provisions on data link layer mainly refer to the relevant provisions on CAN2.0B and SAE J1939. The 29-bit extended frame identifier is used and redefined. The bus communication rate is 250Kbps. For details, please refer to the CAN communication protocol.

DRIVING AND HYDRAULIC INTEGRATED POWER SYSTEM

DRIVING AND HYDRAULIC INTEGRATED POWER SYSTEM

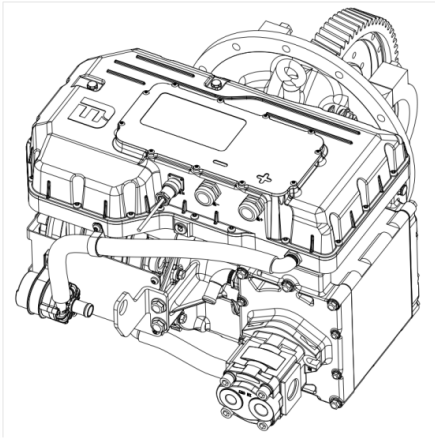

1. General Performance

The driving and hydraulic integrated power system includes drive motor, drive motor controller, oil pump motor, oil pump motor controller, reducer assembly, and related cooling system, oil way system and other auxiliary parts. The entire system can provide driving force for the complete vehicle to ensure driving, and meanwhile provide power for the oil way system to cooperate in the lifting and handling of the vehicle. The driving and hydraulic integrated power system has working status information collection, information transfer and safety management functions.

2. Safety Information

⚠ Danger

- Do not directly touch the control signal and power signal terminals, veneer components and controller parts with your hands!
- Do not turn or remove the fixed screws, breather valve and gasket of the controller at will!
- Follow the Instructions strictly for wiring; otherwise, there is a risk of electric shock or damage to the controller!
- Make sure that the input power is safely disconnected before the wiring; otherwise, there is a risk of electric shock!
- The wiring screws at power terminal must be tightened; otherwise, there is a risk of damage to the controller!
- After the controller is powered on, touch is prohibited; otherwise, there is a risk of electric shock!
- The start and stop of the controller cannot be controlled by powering on or off; otherwise, there is a risk of damage to the controller!
- Make sure that the controller is in the state of no output before closing/opening of the controller input switch or contactor; otherwise, there is a risk of damage to the controller!

DRIVING AND HYDRAULIC INTEGRATED POWER SYSTEM

Danger

- The must be conducted by professionals!It is forbidden to carry out product maintenance and inspection or replace parts during powering on; otherwise, there is a risk of electric shock!
- Wait for more than 5 minutes after powering off to ensure that the residual voltage of the electrolytic capacitor drops below 36V before maintenance, inspection or replacement of parts!

Caution

- Handle with care and hold the bottom plate of the product during handling to prevent damage to the controller by crashing or dropping!
- Avoid dropping the hole drilling residues, thread residues and screws into the controller during installation; otherwise, the controller may malfunction!
- Do not touch the fan or radiator directly; otherwise, there is a risk of mechanical damage and burns!
- Try not to touch the component body during maintenance, inspection or replacement of parts; otherwise, there is a risk of static damage to the device!
- All pluggable devices can be plugged and unplugged only when the power is disconnected!

DRIVING AND HYDRAULIC INTEGRATED POWER SYSTEM

3. Emergency Treatment Measures

Traffic accident:





- ① When the vehicle stops steadily, immediately open the car door, pull out the car key, and turn off the main power switch (if conditions permit, the professionals shall disconnect the manual maintenance switch);
- ② Notify our after-sales department, and it is not allowed to use the vehicle again before the after-sales department gives the judgment result that the system is safe.

Fire:

- ④ Personnel leave the vehicle quickly and call the fire telephone according to the site conditions.
- ⑤ When personal safety is guaranteed, the following operations can be carried out with conditions:
 - (1) If the wiring harness emits smoke and catches fire, then use carbon dioxide or dry powder extinguishers to extinguish,
 - (2) if the battery pack catches fire, then use a high-pressure water gun at a long distance to extinguish the fire,
 - (3) If dense smoke is inhaled, please seek medical attention as soon as possible.
- ⑥ If the fire is caused by abnormal charging, then be sure to turn off the charging power supply in the first time and then extinguish the fire.

The following symbols, found throughout this manual, alert you to potentially hazardous conditions to the owner and the operator. Become completely familiar with the truck before proceeding with operating, checking and servicing.

This manual and decals affixed to the truck use the following safety alert indications.

SIGNAL WORD	CLASSIFICATION
 DANGER	Failure to follow the instructions in the message will likely cause a serious accident or death.
 WARNING	Failure to follow the instructions in the message might cause a serious accident or death.
 CAUTION	Failure to follow the instructions in the message may cause personal injury or damage to the truck or other property.
 NOTE	The information will help to prolong the service life of the truck. The message is not directly related to accident prevention.

3.OPERATION

CONTENTS

PROPER OPERATION.....	3 - 2
HOW TO USE THE BATTERY.....	3 - 9
LOAD HANDLING.....	3 - 13
STORING.....	3 - 15

PROPER OPERATION

To operate the lift truck safely and get the most out of it, correct procedures are described on the following pages:

DURING BREAK-IN

We recommend to operate the truck under light load conditions for the first stage of operation to get the most from it. Especially, the requirements given below should be observed while the truck is in a stage of 200 hours of operation.

- ⚠ **Always warm up your truck before putting it into work regardless of the seasons.**
- ⚠ **Perform specified preventive maintenance services carefully and completely.**
- ⚠ **Never "race" or play games with the truck. Avoid sudden stops, starts or turns.**
- ⚠ **Oil changes and lubrication are recommended to do earlier than specified.**

RELATIONSHIP BETWEEN LOAD AND STABILITY OF TRUCK

The lift truck keeps a balance of weight between the truck and the load on the forks with the center of the front wheels as a fulcrum when the rated capacity load is placed in position.

Due care should be paid to the weight and the load's center of gravity to maintain stability.

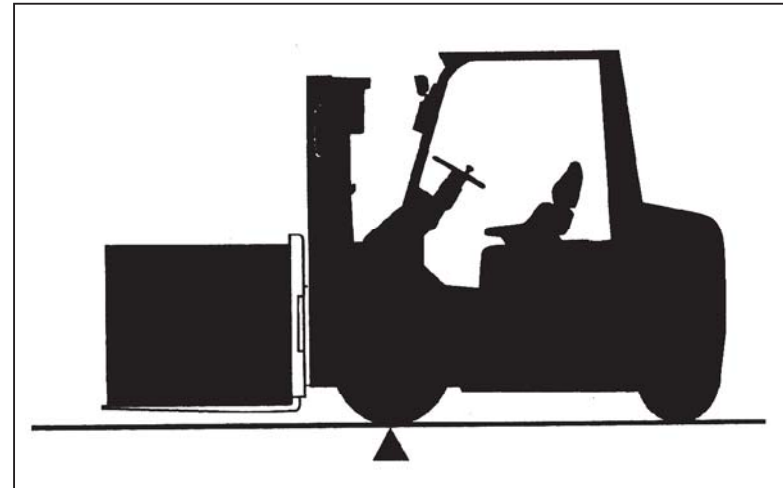

If the rated capacity is exceeded, there is a danger of the rear wheels being raised and in the worst case, the truck will turn over, resulting in a fatal accident. The load placed near the fork tips practically has the same effect that the weight of the load is increased. In this case, the load weight must be reduced accordingly.

PROPER OPERATION

BASIC LOAD CENTER AND RATED LOAD

⚠ CAUTION

When traveling with loads, keep the forks 15 to 20 cm (6 to 18 in.) above the ground surface and keep the mast tilted back fully.

The allowable load of a truck equipped with an attachment is reduced in comparison with that of the standard truck. If the truck is equipped with a load-handling means such as a hinged fork, load grab, or rotating clamp, its allowable load will be reduced as compared with that of the standard truck (a truck without any attachment) for the following reasons: Never exceed the allowable load indicated on the load chart attached onto the truck or attachment.

Reasons for a reduction in the allowable load:

- 1) The weight of an attachment is added.
- 2) The attachment shifts the basic load center position

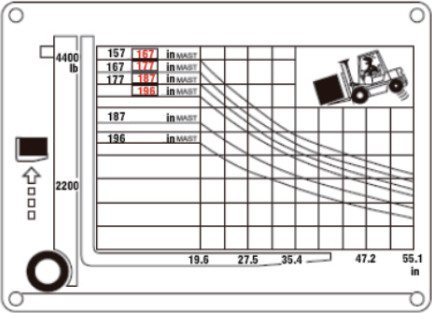

The basic load center is the distance from the front face of the forks to the load's center of gravity. The chart given above shows the relationship between the basic load center and the weight of loads to be allowable for the 2-ton truck. This chart is called a

THE STABILITY OF LIFT TRUCK

The stability of lift trucks is stipulated in JIS (Japanese Industrial Standards) or in other national industrial standards, and lift trucks are manufactured complying with these standards. However, note that the stability of lift trucks is not assured at all times, but only when the following conditions are properly observed.

- The ground or floor surface is level and hard.**
 - The truck travels under standard loaded or unloaded condition.**
 - The truck is operated carefully and the forks are properly manipulated; that is, the forks are not tilted forward more than necessary, when stacking or unstacking.**
 - Load handling is carried out carefully and slowly.**
- In addition, keep the truck in good working condition for safe operation and traveling.

Standard unloaded condition
This means that the forks are raised 30 cm (12 in.) above the ground or floor surface and tilted back fully without loads.

Standard loaded condition
This means that the forks are raised 30 cm (12 in.) above the ground or floor surface with a load placed at the basic load center position of the forks

TRAVELING AND STARTING ON A SLOPE

When traveling on a slope with a load on the forks, have the load pointed up-hill.

When traveling on a slope without load, have the rear end of the truck pointed up-hill to prevent the drive wheels from skidding.

PROPER OPERATION

TRANSPORTING LIFT TRUCK

CAUTION

Transporting the lift truck on a trailer truck

Securely lock the lift truck in place to prevent it from moving on the trailer truck by fastening with wire ropes and blocking the wheels.

When loading or unloading the lift truck onto or from a trailer truck or when traveling over public roads, pay attention to the overall length, overall height, and weight and

CAUTIONS TO BE TAKEN WHEN LOADING AND UNLOADING LIFT TRUCK

CAUTION

Never try to move the steering wheel when halfway up a ramp; otherwise the truck might fall down, leading to a serious accident.



Use ramps of sufficient length, width, and strength.



Before loading or unloading the lift truck, make sure to apply the parking brake to the trailer truck and block its wheels.



Ramps must be securely locked to the trailer truck. Their surface must be clean and dry.



Loading and unloading must be carried out on a level surface. The right and left ramps must be the same height.



When loading the lift truck onto a trailer truck, back it up the ramps slowly with care.

OPERATING LIFT TRUCK

GETTING ON AND OFF

CAUTION

Do not hold the steering wheel when getting on the truck. Do not jump on or off the truck. You might slip or tumble down, leading to personal injury.

- 1) Make sure there is no one around the truck.
- 2) Using the safety step and hand grip, get on the truck from the left side of the truck.
- 3) Fasten the seat belt for your safety's sake. It will help prevent you from getting injured when the truck tips over.

BEFORE STARTING LIFT TRUCK

CAUTION

It takes about 1 second after the key switch is turned on, to make the control circuit ready for functioning to allow the truck to start.

Do not place the F/R lever in forward "F" or reverse "R" before the key switch is turned on; otherwise the truck might not start.

If this is the case, return the F/R lever to neutral "N".

Do not bottom the accelerator pedal rapidly. It is

CAUTION

Make sure there is no one around the truck and let other workmen and bystanders know you are starting up by honking.

- 1) Pull back the lift lever to raise the forks 1.96 to 3.93 in from the ground or floor surface.
- 2) Pull back the tilt lever to tilt back the mast fully.
- 3) Pull back the lift lever again to raise the forks 5.9 to 7.8 in from the ground or floor surface.
- 4) Make sure there is no one around the truck and let other workmen and bystanders know you are starting up by honking.

STARTING LIFT TRUCK

CAUTION

Press the brake pedal fully before shifting the F/R lever into forward "F" (or reverse "R")

CAUTION

When traveling in reverse, look in the direction of travel and be alert for pedestrians, other trucks or obstacles in your path of travel. Do not rely too much on the sideview mirrors.

- 1) Step on the brake pedal.
- 2) Place the F/R lever into forward "F" (or reverse "R")
- 3) Release the parking brake.
- 4) Remove your foot from the brake pedal and step down the accelerator pedal gradually.
- 5) You can control the traveling speed by stepping on the accelerator pedal.

NOTE

Do not keep your foot on the brake pedal after starting the truck.

PROPER OPERATION

TURNING

WARNING

Note that the higher the traveling speed or the smaller the turning radius, the possibility of the truck rolling over sideways increases when making a travel turn.

CAUTION

Note that the rear end (counterweight) of the truck swings when you turn the truck.

Unlike general passenger cars, the steer wheels are located at the rear of the truck. This causes the rear end of the truck to swing out when a turn is made. Slow down the truck and move toward a side to which you are turning. The steering wheel should be turned a bit earlier than as with the front-wheel steering car.

Grab the steering wheel knob with your left hand.

Your right hand is used to operate the load handling levers.

Before making a turn, slow down to about 3.1 mph and turn the steering wheel slowly, making sure there is no one around the truck.

SIMULTANEOUS OPERATION OF TRAVELING AND LOAD HANDLING (INCHING)

WARNING

Simultaneous operation (inching operation) of traveling and load handling requires skillfulness. The operator is required to know the shape of the load he is going to handle, the possibility of slipping, deformation, and load's center of gravity. In addition, he needs to lift the forks horizontally at a slow speed, ensuring the stability of the truck. Use due caution when carrying out inching operation.

Do not tilt the mast forward when the load is raised high.

Do not tilt the mast forward unless the load is over a stack or at a low lift height.

To reduce the risk of the truck tipping over, do not lift the

- 1) Under the usual traveling posture, approach the pick-up or deposit area up to 118.1 to 196.8 in from it.
- 2) Step on the brake pedal fully (bring the truck to a complete stop).
- 3) Step on the accelerator pedal to gain a traveling speed suitable for the work.
- 4) Operate the lift lever to lift the forks.

SLOWING DOWN

Ease up on the accelerator pedal. If necessary, step on the brake pedal.

If not in emergency, you can slow down and stop the truck by releasing the accelerator pedal. Rapidly releasing the accelerator pedal will not bring the truck to a rapid stop.

If you need to stop the truck immediately, step on the brake pedal fully.

PARKING

CAUTION

Safe parking

Park the truck on a level ground, preferably in a wide area.

If parking the truck without load on a slope is unavoidable position the load handling means down-hill and block the wheels to prevent accidental roll.

Park the truck in a designated area or out-of-traffic area. If necessary, put signposts or signal lights around the truck.

Park the truck on a hard ground. Avoid soft ground, deep mud or slippery surfaces.

If you cannot lower the forks on the ground due to a broken load handling system, put a caution cloth to the fork end and park in an out-of-traffic area.

Pay attention to the ground condition because it might be slippery.

Dismount from the truck after making sure it has come to a complete stop. Do not dismount from the truck in motion.

Never jump off the truck.

Dismount from the truck, facing the truck and using the

Ease up on the accelerator pedal and if necessary step on the brake pedal to stop the truck. Place the F/R lever in neutral "N".

PROPER OPERATION

Park the truck in an out-of-traffic area and follow these steps:

- 1) Pull the parking brake lever fully to apply the parking brake.
- 2) Lower the forks on the ground.
- 3) Turn the key switch OFF.
- 4) Remove the key and keep it.
- 5) Dismount from the truck carefully.

GROUND CONDITION

CAUTION

Use due caution when traveling on a rough surface.

When crossing a railroad, be sure to stop and ensure the safety, and cross the railroad track at an angle.

Go around obstacles such as rocks and stumps, or pot holes. If unavoidable, reduce the speed and go over them slowly and carefully. Use caution not to damage the bottom of the truck. Cross a small bump diagonally if the aisle width is enough to do so.

Lift truck performance depends upon the ground condition or floor condition and travel speed should be adjusted properly.

TRAVELING ON SNOWY OR FROZEN ROAD

When traveling on a snowy or frozen road, avoid sudden acceleration, stops or turns; otherwise the truck might skid to cause a serious accident.

Control the traveling speed carefully using the accelerator pedal.

HOW TO USE THE BATTERY

NOTES ON USE OF LITHIUM BATTERY

- Upon adherence to electrolyte of the lithium battery, immediately rinse with plenty of clear water. The electrolyte of the lithium battery contains dilute sulfuric acid, which can corrode clothing or skin. If the electrolyte is adhered to clothing or skin, immediately rinse with plenty of clear water. If the electrolyte of the lithium battery accidentally gets into your eyes, immediately rinse with plenty of clear water, and then urgently seek for medical treatment.

- Please use safety glasses during use of the battery. lithium
Wear rubber gloves, rubber boots, protective glasses during exchange charging of the lithium battery, electrolyte replenishment and adjustment of specific gravity.

- Disposal upon accidental ingestion of the electrolyte of lithium battery
Upon accidental ingestion of the electrolyte of lithium battery, immediately drink plenty of clear water or milk mixed with egg whites or salad oil, and then urgently seek medical treatment.

- Do not disconnect the socket during powering on.
- Do not place metal tools above the lithium battery.

- The lithium battery should be charged in a well-ventilated place
- The battery car uses high voltage lithium battery.
- No open flames for lithium battery
The Lithium battery has a risk of explosion due to generation of hydrogen gas. Therefore, do not use items with ignition sources such as lighters around the lithium battery. To prevent the generation of sparks, be sure to turn off the charger switch when the cables of the lithium battery and charger are disconnected.

HOW TO USE THE BATTERY

For vehicles powered by lithium batteries, the voltage of lithium battery generally is high, and there is a risk of electric shock or injury after touch with the lithium battery.

- Pay attention to static electricity during cleaning
When cleaning the top and surrounding connecting parts of the lithium battery with a dry cloth and a duster or covering the lithium battery with a plastic film, it is easy to generate static electricity, which may cause an explosion.

- Pay attention to the static electricity on human body
Before checking and cleaning of the lithium battery, remove the static electricity on the body where has been in contact

- Pay attention to the static electricity on human body
Before checking and cleaning of the lithium battery, remove the static electricity on the body where has been in contact with the metal in a place far away from the battery before the start of work.

- Keep the lithium battery or lithium battery pack away from dangerous items or materials, such as corrosive chemicals, dangerous machinery, and high-temperature environments.

- It is forbidden to remove, squeeze, puncture, place at high temperature or bake lithium batteries, to prevent the lithium batteries from being subjected to excessive large vibration, impact of external forces, or falling from high places, because it may cause personal injury or property damage.

- Treatment of accidents caused by unreasonable use of lithium batteries
Unreasonable use of this series of products may cause smoke, such as external short circuit, overcharge, and too high ambient temperature. In case of smoking, please cut off the power in time, use carbon dioxide or dry powder extinguisher for treatment, and bury with sand or mud. In the entire process, the crowd must be evacuated in time and an alarm must be given (if necessary).

Unreasonable use of this series of products may cause the swelling of lithium battery cell, and in severe cases, may cause the case rupture or cracking. At this time, please stop using the lithium battery immediately, and contact our technical department or after-sales service department for treatment method.

- It is forbidden to short out the positive and negative poles of the lithium battery directly. Any metal or other conductive objects other than the compression bolts of the lithium battery pole column and the conductive belt should be prevented from contacting the positive electrode and negative pole of the lithium battery, because it may cause personal injury or property damage.

- It is forbidden to expose or leave the lithium battery in an environment with the temperature of 60°C and above for a long time. It is forbidden to try to heat or throw the lithium battery into a fire, because it may cause personal injury or property damage.

- It is forbidden to charge lithium batteries with charging equipment (charger, DC power supply, etc.) that are not approved by VEDAI, because it may cause personal injury or property damage.

- It is forbidden to immerse the lithium battery into water or other conductive liquids, because it may cause personal injury or property damage.

- Children and other people who lack knowledge about safe use of lithium batteries are prohibited from using this series of products, because such use may cause personal injury or property damage.

- It is forbidden to use this series of products with other models or types of lithium batteries in series or in parallel, because such use may cause personal injury or property damage; it is forbidden to connect the entire power system containing the lithium battery protection circuit board or lithium battery management system in series or in parallel, because this operation may cause personal injury or property damage, and if necessary, please contact the relevant technical department of the company to obtain correct technical support.

HOW TO USE THE BATTERY

● Emergency Treatment Measures for Lithium Battery

1. Traffic accident:

- When the vehicle stops steadily, immediately open the car door, pull out the car key, and turn off the main power switch (if conditions permit, the professionals shall disconnect the manual maintenance switch);
- Notify our after-sales department, and it is not allowed to use the vehicle again before the after-sales department gives the judgment result that the system is safe.

2. Fire:

- Personnel shall leave the vehicle quickly and call the fire telephone according to the site conditions.
- When personal safety is guaranteed, the following operations can be carried out with conditions: (1) If the wiring harness emits smoke and catches fire, then use carbon dioxide or dry powder extinguishers to extinguish, (2) if the battery pack catches fire, then use a high-pressure water gun at a long distance to extinguish the fire, (3) If dense smoke is inhaled, please seek medical attention as soon as possible.
- If the fire is caused by abnormal charging, then be sure to turn off the charging power supply in the first time and then extinguish the fire.

PICK-UP

CAUTION

The fork spacing should be usually adjusted for more than 1/2 and less than 3/4 of the pallet width.

- 1)The fork spacing should be as wide as possible to maintain proper balance of the load.
- 2)Place the truck right in front of the load to be handled.
- 3)The pallet should be positioned parallel with both forks.
- 4)Insert the forks into the pallet as far as possible.
- 5)To raise the load from the ground:
 - ①Once lift the forks 1.96 to 3.93 in off the ground or floor surface, and make sure the load is stable.
 - ②After making sure the load is stable and evenly positioned on the forks, tilt back the mast fully and lift the forks up to 5.9 to 7.8 in off the ground or floor surface. Start running.
- 6)When handling a bulky load which restricts your vision, drive the truck in reverse or sideways.

STACKING

CAUTION

- **Never tilt the mast forward with the load upraised except when the forks are over the rack or a stack.**
- **Do not leave the truck with the load upraised.**

- 1)When approaching the deposit area, slow down your truck.
- 2)Stop the truck before the area where your load is to be deposited
- 3)Confirm the safety of the deposit position.
- 4)Tilt the mast forward until the forks become horizontal.
- 5)Raise the forks until they are a little higher than the deposit position.
- 6)Move forward slowly to place the load directly over the desired area and stop the truck.
- 7)Make sure the load is just over the desired area. Slowly lower the load into position. Make sure the load is securely stacked.
- 8)Disengage the forks from the pallet or load using necessary lift-tilt operation, and then back away.
- 9)After making sure the fork tips leave the pallet or load, lower the forks to the basic traveling position(5.9 to 7.8in off the ground or floor surface).
- 10)Tilt back the mast.

LOAD HANDLING

UNSTACKING

- 1)When approaching the area where the load is to be retrieved. slow down the truck.
- 2)Stop the truck right in front of the load where the distance between the fork tips and the load is about 11.8 in.
- 3)Check the condition of the stack.
- 4)Tilt the mast forward until the forks become horizontal and lift up to the position of the pallet or skid.
- 5)Make sure the forks are positioned properly for the pallet. Move forward slowly to insert the forks into the pallet as far as possible. Stop the truck.
*If the forks are hard to be fully inserted, use the following procedure:
 - ①Move forward to insert 3/4 of the forks. Raise the forks 1.96 to 3.93 in, back away 3.93 to 7.87 in with the pallet or skid on the forks. Lower the pallet or skid on the stack.
 - ②Move forward again to insert the forks into the pallet fully.
- 6)Raise the forks 1.96 to 3.93 in off the stack.
- 7)Confirm the safety behind the truck and back away slowly to the position where the load can be put safely.
- 8)Slowly lower the load to a height of 5.9 to 7.8 in above the ground or floor surface. Tilt back the mast fully and move th the desired area.

BEFORE STORING

CAUTION

If any time your lift truck is found to be in need of repair, defective or unsafe, the condition should be reported to the supervisor, and the truck should be taken out of service until it has been restored to safe operating condition.

Before storing the lift truck, clean it thoroughly and perform inspection using the following procedure:

Wipe away grease, oil etc., adhering to the body of the truck with shop rag. Use water, if needed.

While washing the truck, check the general condition of the truck. Especially check the truck body for dents or cracks, the tires for wear or nails or stones in the tread.

Check for leakage of hydraulic oil.

Apply grease, where needed.

Check for looseness of the hub nuts and cylinder piston rod joints.

Check the mast rollers to see that they rotate smoothly.

Lift the forks up to the top position and lower to the lower limit.

Repeat this procedure to prime oil into the lift cylinders.

DAILY STORAGE

Park the truck at a specified place and block the wheels.

Place the F/R lever in neutral "N" and pull the brake lever fully.

Remove the starter key and keep it in a safe place.

STORING

LONG-TERM STORAGE

Perform the following checks in addition to "BEFORE STORING" and "DAILY STORAGE" operations.

- Taking the rainy season into consideration, park the truck at a higher and hard ground.
- Remove the battery from the truck.
- Even though the truck is parked indoors, if the place is hot or humid, the battery should be kept in a dry, cool place, and charged once a month.
- Apply anti-rust to the exposed parts such as cylinder rods and shafts that tend to rust.
- Cover components which may be caught with humidity, such as the air breather and air cleaner.
- Put the truck in the operating state once a week and turn the key switch on. Warm it up sufficiently before moving the truck a little back and forth.
- Avoid parking on a soft ground such as an asphalt ground in summer.

OPERATING AFTER LONG-TERM STORAGE

- Remove covers used to seal off moisture.
- Remove antirust from the exposed parts.
- Drain foreign matter and water from the hydraulic oil tank.
- Charge the battery and mount it on the truck. Connect the cables.
- Perform preoperational checks carefully.

PROHIBITION OF WASHING TRUCK BODY AND BATTERY WITH WATER

- In general, do not wash the truck body or battery with water using a hose or steam cleaner. The tires may be washed with water, but floor board should be removed from the truck body before washing. While washing, use caution not to splash water over the accelerator unit. If possible, remove the accelerator unit.

- If water is splashed over the battery, water or foreign matter might enter through the cap, leading to a short battery service life. In addition, the electrolyte might spill to cause environmental pollution. Wipe any dirty battery case with a wet shop rag and dry it completely by blowing air. If necessary, leave it to a specialist. If the battery case needs to be cleaned, dismount it from the truck. After cleaning, the battery must be dried completely before mounted again on the truck.

Do not clean the following electrical components with water

- Controller and contactors
- Motors (drive, pump)
- Transformer (in the side cover)
- Charger control panel (in the hood)
- Battery unit and receptacles
- Meter panel box
- Accelerator unit (under floorboard)

STORING

CLEANING

- Pull the parking brake lever fully to stop the truck.
- Turn the key switch OFF and disconnect the battery receptacles.

AFTER CLEANING





- Use compressed air to blow away drops of water and make sure the washed areas are completely dry.
- When operating the truck for the first time after cleaning, perform a trial run and make sure the truck operates without any problem.

WASHABLE ITEMS

Item	Washing with water	Remarks
Frame surfaces, mast, forks, tires and rear axle	Allowed	Use caution not to splash water on unwashable components.
Counterweight	Allowed	Use caution not to splash water on the cover joints of the battery inside the rear cover.
Inner surfaces of side cover	Allowed	Use caution not to wet the components inside covers.
Floorboard and floorboard mat	Not allowed	Do not wash with water because the motors are located under the floorboard. Clean them by blowing air. If severely contaminated, remove them and clean with water. Make sure they are completely dry before reinstalling.
Battery hood and battery case	Not allowed	Clean them by blowing air or wiping with wet shop rag.
Meter panel box and steering wheel	Not allowed	Ditto
Motors	Not allowed	Ditto

The following symbols, found throughout this manual, alert you to potentially hazardous conditions to the owner and the operator. Become completely familiar with the truck before proceeding with operating, checking and servicing.

This manual and decals affixed to the truck use the following safety alert indications.

SIGNAL WORD	CLASSIFICATION
 DANGER	Failure to follow the instructions in the message will likely cause a serious accident or death.
 WARNING	Failure to follow the instructions in the message might cause a serious accident or death.
 CAUTION	Failure to follow the instructions in the message may cause personal injury or damage to the truck or other property.
 NOTE	The information will help to prolong the service life of the truck. The message is not directly related to accident prevention.

4. MAINTENANCE

CONTENTS

PREOPERATIONAL CHECKS.....	4 - 2
STORING.....	4 - 7
PREOPERATIONAL CHECKS.....	4 - 8
INSTRUCTIONS FOR USAGE AND STORAGE OF LITHIUM BATTERY.....	4 - 13
PERIODICAL CHECK.....	4 - 14

PREOPERATIONAL CHECKS

To ensure the safety in operation and performance of the lift truck, be sure to check the following daily before starting the operation.

⚠ CAUTION

If any abnormality is found in preoperational checks, hang a sign of DO NOT OPERATE on the control area, remove the start key, and report the condition to the supervisor. The operation should be halted until the truck is completely repaired.

Check for oil leaks as it may cause a fire.

Waste fluid due to lubricant changes should not be thrown away (into sewage, earth, or incinerator, etc.). It will cause water, soil, and air pollution and the responsible personnel will be punished by law.

CAUTION IN CHECKING

Use genuine parts only.

Use genuine or recommended lubricants only.

Clean the oil fillers and grease fittings using a brush or cloth before supplying oil or greasing.

Oil level check and supply should be performed with the truck parked on the level surface.

Preventive maintenance services should be done in an orderly manner with utmost care to prevent personal injury.

Make sure to remove the battery receptacle before checking electrical equipment.

If an inspection should be carried out under the raised forks, fix them by placing stable supports between the fork mast inner frame and the ground to prevent the forks from falling down.

Any time the truck or controls are found to malfunction, stop the operation of the truck immediately and report the condition to the supervisor. Never operate a fault truck.

PREOPERATIONAL CHECKS

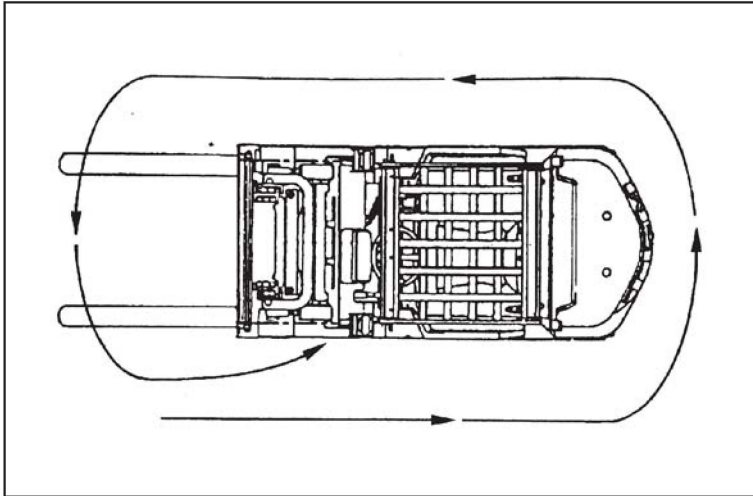

■ General condition

Check the truck body for dents, cracks, and tires for wear or nails caught in the tread.

■ State of the truck

Check the inclination of the truck. If the truck is tilted to either side, it suggests that the tires or wheels are defective. Contact your local dealer.

■ Oil and water leaks

Check for oil and water leaks under the truck. If there is a pool of oil or water on the ground or floor, contact your local dealer.

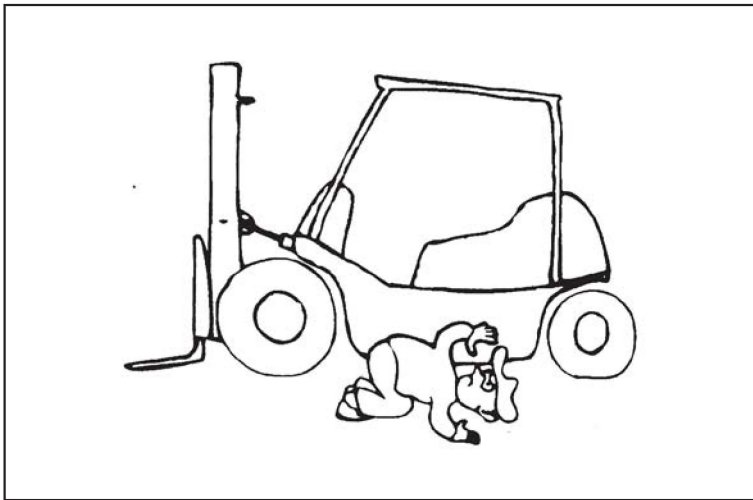

PREOPERATIONAL CHECKS

ITEMS TO BE CHECKED

1 CHECK THE RESULT OF REPAIRS PERFORMED ON PREVIOUS CHECKING

⚠ CAUTION

Never try to operate a faulty truck.

Check to see if any defect found on the previous inspection has been repaired properly.

2 TIRE INFLATION PRESSURE AND TIRE CONDITION CHECK

⚠ CAUTION

The tires of the lift truck have a high inflation pressure. Make sure the tires and rims are normal and inflate the tires to the standard air pressure. Do not overinflate the tires.

When using an air compressor to inflate the tires, first adjust the compressor air pressure properly. Failure to do so will cause a serious accident since the compressor delivers the maximum pressure.

A small bend of the rim or a slightly damaged tire might cause a flat tire, leading to a serious accident. If you find any failure, contact your local dealer.

Keep the inflation pressure of the tires always at proper level.

📄 NOTE

Low air pressure reduces tire service life. Unevenness of air pressure between right and left tires will cause hard steering or the truck to wander.



The standard tire pressure is indicated on the decal at the left side of the front guard.

Front wheels (both single and double tires)	700 kPa (7 kg/cm ²)
Rear wheels 2- 4.0ton	850 kPa (8.5 kg/cm ²)

Turn the tire valve cap counterclockwise and remove it. Using a tire pressure gauge, measure the inflation pressure and adjust for the standard inflation pressure.

Then, make sure there is no air leakage from the tire valve, re-install the tire cap.

Check that each tire does not get damaged at the tread surface or side face or bending at the rim.

The lift truck needs tires that have a high inflation pressure for carrying heavy loads.

PREOPERATIONAL CHECKS

HUB NUT CHECK

CAUTION

A loose hub nut can be dangerous. In the worst case, the wheel comes off the truck, causing the truck to tip over.

Check the hub nuts for looseness. All hub nuts should be tightened to the specified torque.

HUB NUT TIGHTENING TORQUE

	Unit: N-m (kgf-m)	
	Front wheels (Single tire)	Rear wheels
2- to 2.5-ton trucks	471-549 (48-56) The double-tire specification is the same.	128 - 190 (13 - 19.4)
3-to 3.5-ton trucks	471-549 (48-56) The double-tire specification is the same.	

Tightening order for double nuts

Double tires are installed by locking the inner tire rim with inner hub nuts (square nuts) and then by locking the outer tire rim with outer hub nuts (hex. nuts).

First, tighten the inner nuts (square nuts) in a diagonal order to the specified torque and then tighten the outer nuts (hex. nuts) in the same manner as above.

Tightening drive shaft mounting bolts (nuts)

If any loose bolt or nut is found, retighten it to the following torque :

96 - 11 N-m (9.8 - 11.3 kgf-m)

CAUTION

Do not use tires whose bolts securing the split type rim assembly are loose.

The front single tires and rear tires use split type rim assembly in which the inner and outer rims are bolted together. If any tire has a loose rim connecting bolt, do not operate the truck.

Remove the air valve core to remove the air from the tire and detach the tire from the truck. (For more information about the procedure for removing the tire, see page 4-25.)

Loosen the split rim connecting bolts using a special tool. It is advisable to ask a special to retighten the connecting bolts, disassemble and reassemble the tire and rim, and inflate the tire. (The disassembly, reassembly and inflation of tires should be performed only by qualified personnel.)

PREOPERATIONAL CHECKS

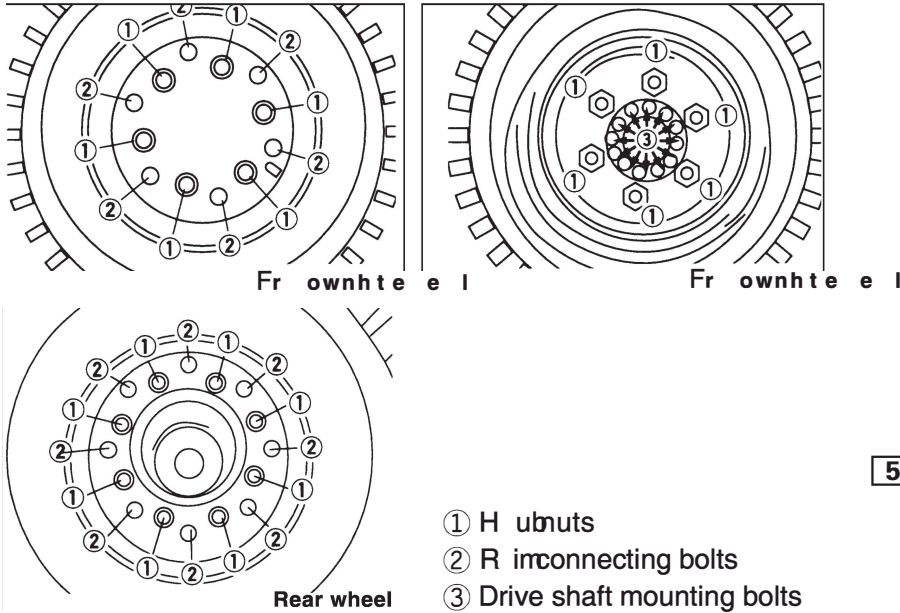

3 OVERHEAD GUARD

Check the overhead guard for loose bolts or nuts or damage.

4 BRAKE FLUID

The level of the brake fluid can be checked from outside without removing the cap of the reserve tank.

Check that the fluid is filled to the specified level.

AIR HOLE

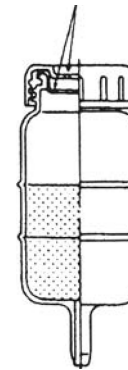

Fluid should be between these two lines.

5 REAR COMBINATION LAMPS

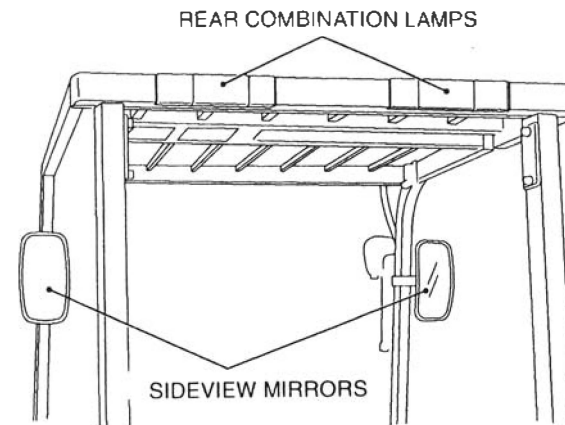

Make sure that the lens of the rear combination lamps (tail lamp, brake lamp, backup light, rear reflector) are not broken or dirty.

6 HYDRAULIC OIL LEVEL

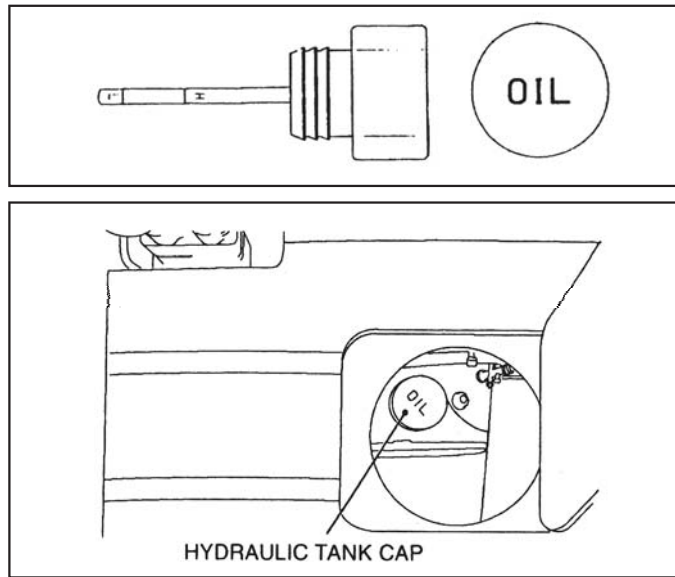

Check the hydraulic oil level with a level gauge. Open the check cover under the floor mat, remove the tank cap, and clean the level gauge with a clean cloth. Then insert the level gauge and pull it out gently to read the maximum oil level. It is good if the oil is up to the upper line on the gauge. If it is below the lower line, suppl oil.

NOTE

Too much oil will cause oil leak.
If the oil level is above the upper line, drain to reduce it to the proper level.
Check the hydraulic oil level with the truck parked on the level surface, the mast vertical and the forks on the ground surface.

7 HYDRAULIC OIL PIPING AND CYLINDERS

Check that oil is not leaking from the hydraulic oil piping and cylinders (lift, tilt).

8 LOAD BACKREST

CAUTION

Do not modify or remove the load backrest.
The operator may get injured by a falling load.
The forks may come off the carriage.

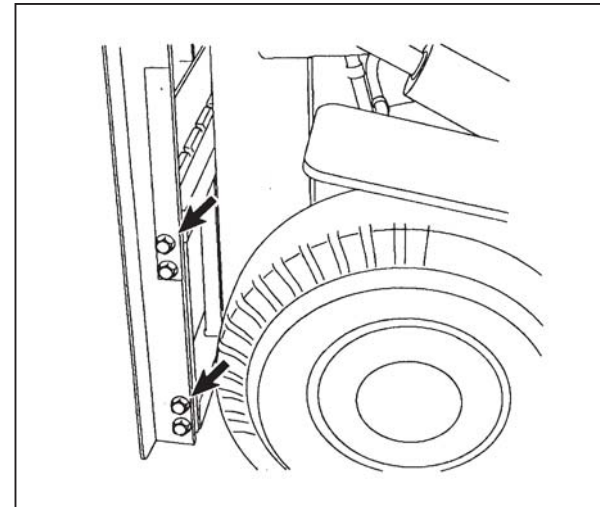

Check that the load backrest is not damaged or mounting bolts (4 on the right and left) are not loose or missing.

PREOPERATIONAL CHECKS

9 FORKS, FORK STOPPERS, AND FORKS LOCK BOLT

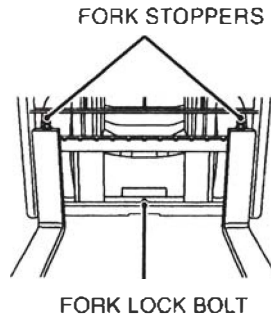

Check that the fork stoppers are properly engaged, the forks are not bent or cracked, and the fork lock bolt is not loose.

10 HEAD LAMP AND FRONT COMBINATION LAMP

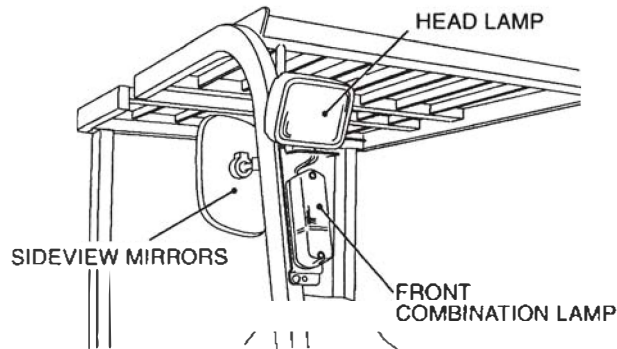

Check that the lens on the head lamp is not damaged or dirty. Check also the front combination lamp in the same manner.

11 SIDEVIEW MIRROR

Check that the sideview mirrors are not dirty or damaged. Adjust the mirror in the driver's seat to gain full rearview when you are seated.

12 PARKING BRAKE OPERATION

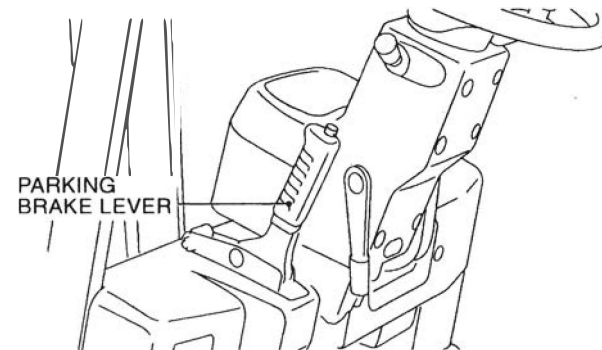

Make sure that the brake works properly. The brake must be properly applied when you pull the lever fully toward you.

[Turn the key switch ON]

13 LOAD HANDLING LEVERS

Check that the load handling levers (lift, tilt, and attachment) are not loose and can be operated smoothly.

PREOPERATIONALCHECKS

14 BRAKE PEDALS

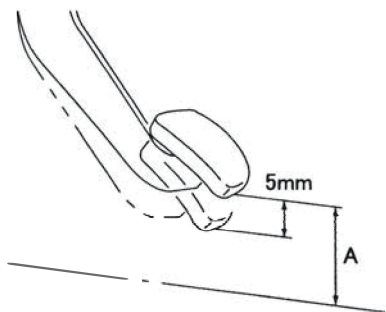

Step on the brake pedal to check that it moves smoothly. Remove your foot from the pedal to see if it returns to its original position. Play of the brake pedal is 0.19 in.

A: Height of the brake pedal from the floor.....3.54 in

15 MAST OPERATION

Operate each of the lift and tilt levers two or three times to check that the forks and mast operate smoothly without squeaking, and that they are not loose.
(If the trysk is egypted with a hydraulic attachment, check it and its control lever as well.)

NOTE

WARMING UP CYLINDERS

Before starting the work, warm up the cylinders. This lubricates packing and seals in the cylinders to make them ready for operation.

16 LIFT CHAIN TENSION

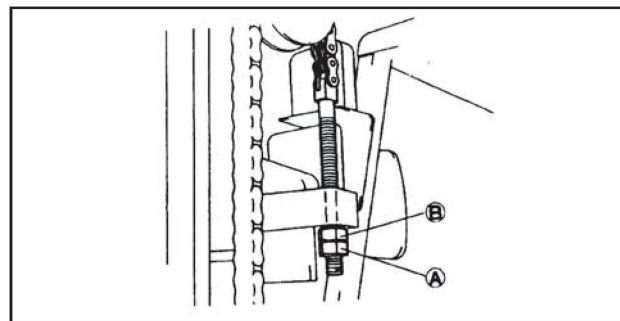

Raise the forks 1.96 in off the ground or floor surface and check that the right and left lift chains have the same tension.
If the tension is not even, adjust it with the chain anchor bolt. After adjustment, securely tighten the lock nut.

17 STEERING WHEEL

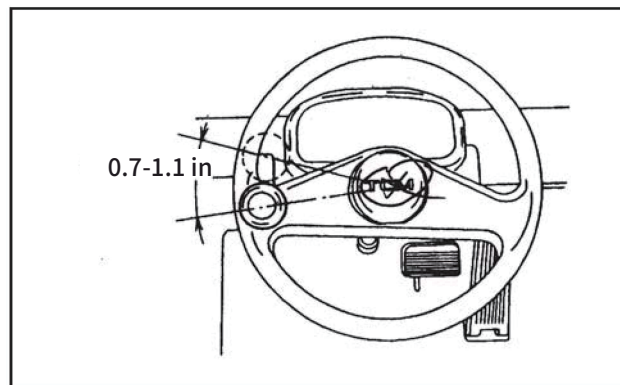

Turn the steering wheel counterclockwise and clockwise to check that the play is within the range of 0.7-1.1 in.
Check also that it does not move vertically

PREOPERATIONAL CHECKS

[Run the truck at a low speed] (in a safe place)

18 BRAKE TEST

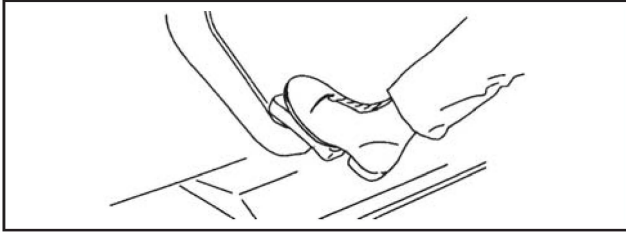

Run the truck slowly and press the brake pedal to check that the truck is braked properly.

Make sure that the brake lamps are lit when the brake pedal is stepped on.

19 STEERING WHEEL TEST

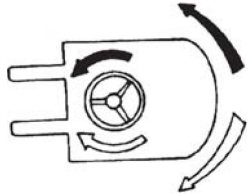

Run the truck at a low speed and slightly turn the steering wheel to the right and left to check that the truck is steered smoothly without problem.

20 PARKING BRAKE TEST

Check that the truck is stopped when the parking brake lever is pulled and that it stays in the same position after stopped.

21 BACKUP LIGHT

Check that the backup light turns on when the change lever is shifted to the backward gear.

PREOPERATIONAL CHECKS

REPLACING TIRES AND REPAIRING FLAT TIRE

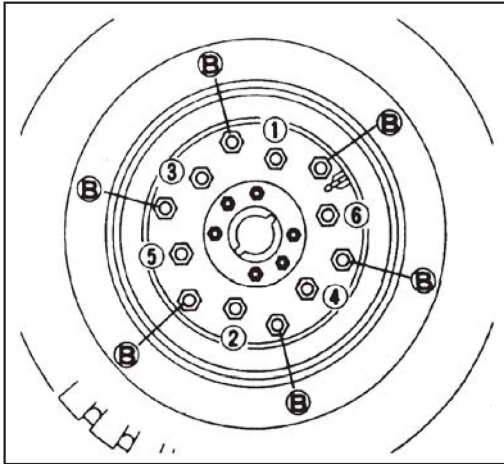

Get tools and jack necessary for replacing tires.

⚠ CAUTION

When removing a tire from the truck, remove air from the tire completely and then remove the hub nuts.

- 1) Park the truck on a level, hard surface and turn off the key switch. Do not have any load on the forks.
- 2) Apply the parking brake and block the wheels. Put a jack under the truck frame.
- 3) Jack up the truck to an extent that the tire

still remains on the ground. Loosen the hub nuts (①–⑥). Do not remove them yet.

4) Jack up the truck until the tire leaves off the ground. Remove the hub nuts.

5) Remove the tire from the hub.

6) When reinstalling the tire, use the reverse order of removal.

Tighten the hub nuts in a diagonal order and evenly.

Hub nut tightening torque: See page 4-4.

After installing the tire to the truck, adjust the inflation pressure to the standard inflation pressure, if needed.

[Rear wheel]

Proceed in the same manner as with the front wheel tire, except that the position of the jack goes under the counterweight.

Hub nut tightening torque: See page 4-4.

⚠ WARNING

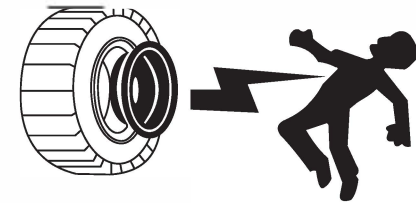

- AVOID SEVERE INJURY OR DEATH.
- Tire servicing requires special training.
- Do not take tires off truck until all air pressure is out. Loosen only WHEEL LUG NUTS "A".
- Do not loosen wheel assembly nuts "B" until all air pressure is out of tire.
- See OPERATOR'S MANUAL for more important instructions for wheel service and re-assembly. Make sure all nuts and bolts are in place and tight
- Never add air to a tire that looks low. Let all air out and check for proper assembly.
- Inflate all tires in a safety cage. See MANUAL for proper pressures.

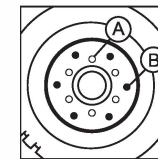

Split-type

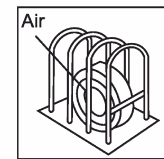

Safety cage

PREOPERATIONAL CHECKS

Remove a tire from the rim

⚠ CAUTION

Before removing a tire from the rim, remove the valve core to release the air pressure from the tire completely. In the case of the split type rim, remove air from the tire before loosening the split rim connecting bolt (B); in the case of the side ring type rim, remove air from the tire before removing the side ring (lick ring).

The assembling of a tire, tube, rim, and flap and inflating of a tire which has been removed from the truck should be done only by qualified personnel. The lift truck uses tires which have an inflation pressure far higher than those of general passenger cars. The use of improper parts or work procedure will cause a serious accident. Tires should be inflated with them attached to the truck or by putting in a safety cage, even if you are qualified to inflate tires.

The split rim connecting bolts must be tightened to the specified torque using the special tool, with the tire inflation pressure removed completely.

Install the split rim on the truck with the rim connecting bolt head pointing

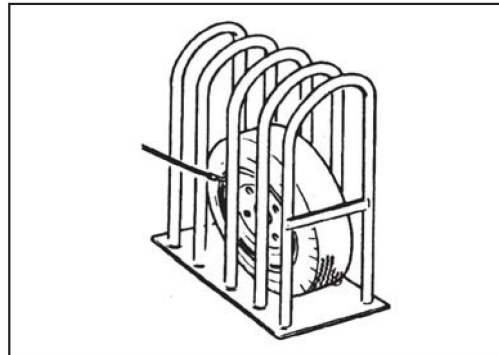
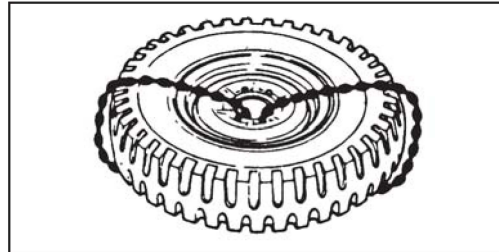

ADJUSTING OPERATING FORCE OF PARKING BRAKE

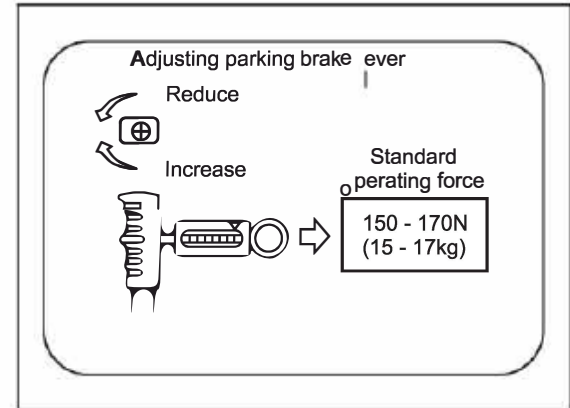
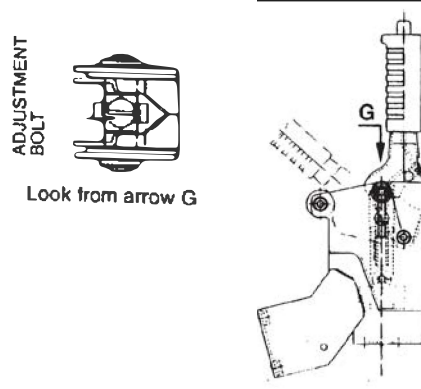

ADJUSTMENT

1) Engage the spring scale to the parking brake lever as shown above and measure the force required to operate the lever.

Standard operating force: 150–170N (15–17 kg).

2) If the measurement is not within the range of the standard operating force, turn the adjustment bolt with a screwdriver to adjust the operating force of the lever.

Reduce by turning the bolt counterclockwise.

Increase by turning the bolt clockwise.

3) The cable of a new truck tends to elongate. It is advisable to adjust it sometimes after the day's work or each shift.

INSTRUCTIONS FOR USAGE AND STORAGE OF LITHIUM BATTERY

Instructions for Usage and Inspection of Lithium Battery

- ① Temperature characteristics of lithium battery:
Working temperature: -20°C-55°C, storage temperature: -20°C-35°C, optimal operating temperature: 25°C-35°C.
- ② The lithium battery system shall be fully charged at least once a week during operation (at least once every three days for operating vehicles).
- ③ The lithium battery system shall be maintained every 3 months to prevent damage to the lithium battery.
- ④ The storage environment of the lithium battery system requires ventilation, dryness, no direct sunlight, no rain and keeping away from heat sources.
- ⑤ Before the first use of the vehicle set aside for a long time is used for the first time, in order to activate the lithium battery system, the lithium battery system shall be maintained for at least once to restore the performance of the lithium battery system to the optimal state.

Description of Lithium Battery Maintenance Method

- ① Description of Maintenance site: spacious, flat and safe, equipped with charging equipment.
- ② Maintenance operation flow: 1) Adjust SOC between 25%-40%; 2) Stop the vehicle securely, turn off the power (turn the key to OFF Gear), then turn on the power (turn the key to ON Gear), check all electric equipment on the vehicle, and ensure that all electric equipment is turned off. 3) Keep powering on for 12-15 hours. During the power-on period, no vehicle or electric equipment is allowed to use. Carry out full charge for once after the completion of maintenance.

Periodic Inspection Requirements

The lithium battery system shall be inspected after the vehicle operates for every 3 months. The inspection items are as follows:

- ① Any scratches, breakage or looseness of the high-voltage and low-voltage wiring harnesses and connectors.
- ② Any sludge, cracks, deformation, odor and bulging of the lithium battery box and high-voltage compartment.
- ③ Any damage to the appearance of the explosion-proof valve of the lithium battery box.
- ④ Secure connection among the lithium battery box, high-voltage compartment and car frame.

PERIODICAL CHECK

CAUTION

Be sure to read INSPECTION AND MAINTENANCE in this manual before checking or servicing the truck.

Periodical checks are required to keep your truck in a safe and good condition.

Continual use of a damaged or abnormal truck may cause a serious accident. Even if it appears to be in a good condition, do not leave it as it is. Early discovery of trouble which may cause breakdown or poor performance will greatly improve the working efficiency and operability, prolong its service life, and lower the maintenance cost.

Preoperational checks, supply of oil and grease, and cleaning of filter elements should be carried out by the customer, and other complicated checks should be carried out by the customer, and other complicated checks should be left to your TUE dealer. If checking or servicing is performed without enough knowledge, special tools or equipment, personal injury may occur.

Every one month of operation is calculated as 200 operating hours in this manual.

PERIODICAL REPLACEMENT OF SECURITY

	Name of Safety Parts	Recommended replacement interval (years)
1	Cups and dust seals of master cylinder and wheel cylinders	1
2	Power steering hose	2
3	Reserve tank tubing	2 - 4
4	Steering actuator rubber boots	2
5	Lift chain	2 - 4
6	Load handling means hoses	1 - 2

In order to perform safe operation, the importance of preventive maintenance of the truck cannot be too emphasized. Especially the parts listed in the table below must be replaced periodically since they are the most important parts for security of the truck and the operator.

Moreover, these security parts are liable to be damaged and deteriorated in the course of time, and it is difficult to determine by ordinary maintenance whether they are beyond their respective service limits or not. The security parts must be replaced with new ones when their respective service limits have been reached, even if they appear to be good.

Any time abnormalities are found, these parts should be replaced even during the replacement term.



NOTE

Replacement of security parts, however, is not subject to warranty claim.

PERIODICAL CHECK

WEEKLY (50 OPERATING HOURS) CHECKS

Check the following items in addition to preoperational checks.

Preoperational and weekly checks should be performed by the user of the battery type fork truck.

Check the truck thoroughly to ensure safe and comfortable operation.

PERIODICAL CHECK

MONTHLY (200 OPERATING HOURS) CHECKS

Check the following items in addition to preoperational and weekly (50 operating hours) checks.

Adjustment and replacement of components and parts listed as monthly check items are difficult and need sufficient technical knowledge and special tools.

Items to be checked

Battery - Equalizing charge
Battery receptacles - Damage and looseness
Wiring - Damage and discoloration
Contactors - Rough surface of contact points
Controller - Cleaning and loose connections
Battery charger - Proper operation
Fuses - Rated capacity and proper installation
Front axle - oil leaks
Front axle mount bolts - looseness (first time only)
Tires - Tread depth and foreign matter in tread
Front and rear axles - Deformation, cracks and damage
Steering gear box - Loose mounting bolts
Rod, arm and king pin - Looseness, bending, and damage

Items to be checked

Rear axle - Proper installation
Brake piping - Mixing of air
Brake system - Operation and looseness of rod and cable
Brake piping - Damage, oil leaks, interference with other parts, and looseness.
Brake fluid - Leakage
Brake drum - Loose mounting
Forks - Cracks and wear
Mast - Cracks and damage
Mast support - Cap bolts (first time only)
(View Mast) - Looseness of lift cylinder tail lock bolts, piston rod head mounting bolts, cylinder U-bolts, piston head guide mounting bolts (first time only)
Lift bracket - Cracks and damage
Loading system rollers - Loose rollers and cracked or damage roller pins
Lift chains and anchor pins - Looseness
Lift chains - Elongation, lubrication, and tension
Pumps - Operation and oil leaks
Valves - Looseness of control levers
Valve control lever micro - switch - Operation and damage
Control valve - Operation of relief valve and tilt - lock valve
Hydraulic oil piping - Oil leaks and damage

Items to be checked

Sheaves - Operation, damage and looseness
Rollers (end, side and retaining) - Operation, looseness and amage
Cylinders (lift and tilt) - Operation and oil leaks
Attachments - General condition and installation
Major bolts and nuts - Retightening (new loaders only)
Chassis - Lubrication

■ LUBRICATING LIFT CHAIN

Apply engine oil to the lift chains using a lubricator or brush. To allow oil to enter between each pin and link plate of the lift chain, observe the following conditions:

- 1) Loosen the chain sufficiently.
- 2) After applying engine oil, move the mast up and down fully at least 10 times.



NOTE

If your lift truck is used near a port or coastal area, the lift chains might be damaged by salty breeze. After a storm or typhoon, it is advisable to wash them with fresh water before lubricating in the manner described above.

PERIODICAL CHECK

■ GREASING POINTS MAST AND STEERING SYSTEM

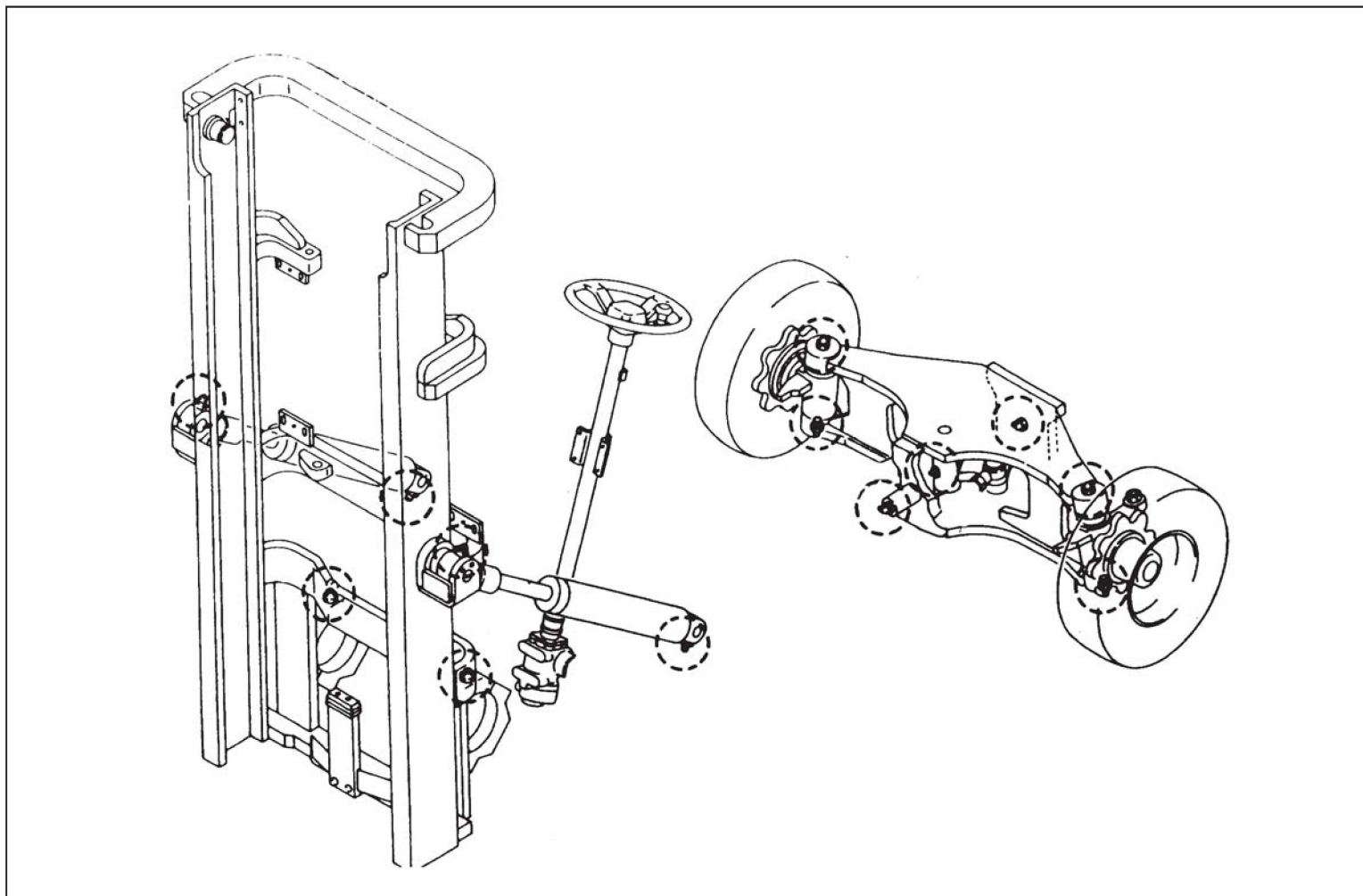

MAST REAR SLIPPER (FOR OPTIONAL MAST)

⚠ WARNING

Do not climb the mast. Do not pour your hand or foot on the connecting members or into the mast assembly. You might get injured if the mast moves accidentally.

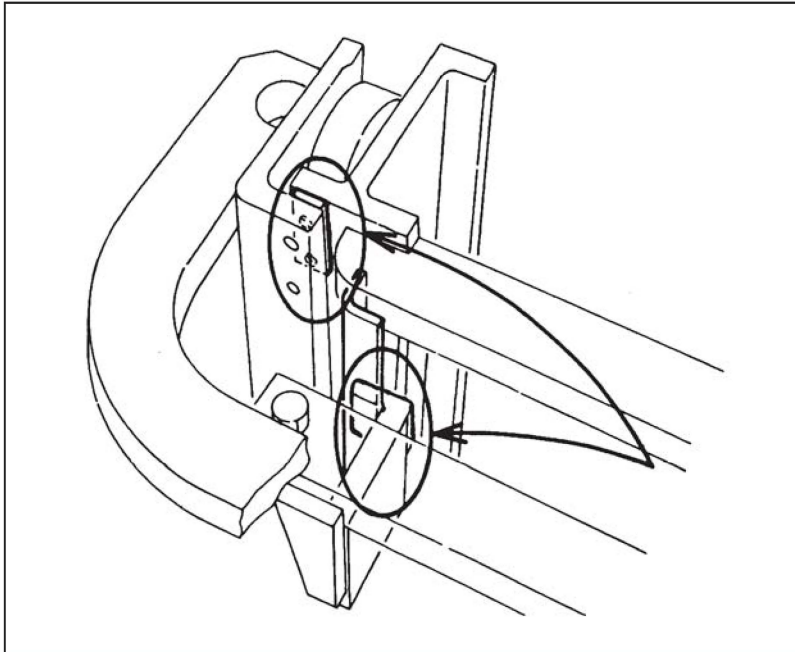

Apply grease on the U-shape guides shown in the sketch (for masts with free lift mechanism)

PERIODICAL CHECK

3 MONTHS (600 OPERATING HOURS) CHECKS

Perform the following checks in addition to preoperational, weekly (50 operating hours), and monthly (200 operating hours) checks.

Items to be checked
Steering gear case - Oil leakage
Steering gear case - Looseness of mounting bolts
Gear box - Oil leakage, looseness of mounting bolts
Fork stopper pin - Damage and wear
Motors (pump and power steering) - Wear of brushes
Motors (pump and power steering) - Rough surface of commutator

6 MONTHS (1200 OPERATING HOURS) CHECKS

Perform the following checks in addition to preoperational, weekly (50 operating hours), monthly (200 operating hours) and 3 months (600 operating hours) checks.

Items to be checked
Contactors - Checking contact points for wear and replacement
Drive motor - Cleaning
Drive motor - Lock current adjustment
Electrical equipment - Insulation
Battery charger - Operation of voltage relay and voltage adjustment
Battery charger electronic timer - Operation and adjustment
Steering gear case - Oil change
Hydraulic oil tank - Cleaning suction strainer
Hydraulic oil - Change
Hydraulic oil system - Replacement of return filter
Relief valve - Adjustment of relief pressure
Mast support - Loose cap bolts
Accelerator pedal - Stopper adjustment
Driver's seat - Damage and loose mounting bolts
Major bolts - Retightening

PERIODICAL CHECK

ANNUAL (2400 OPERATING HOURS) CHECKS

Perform the following checks in addition to preoperational, weekly (50 operating hours), monthly (200 operating hours), 3 months (600 operating hours), and 6 months (1200 operating hours) checks.

Items to be checked
Parking brake - Operation, wear and damage of ratchet
Brake fluid - Change
Master cylinder and wheel cylinder - Operation, oil leaks and damage
Master cylinder and wheel cylinder - Replacement of piston cup and check valve
Wheel brake - Disassembly, inspection, adjustment and replacement of brake drums and brake shoes
Mast support - Wear and damage of bushings
List cylinder - Natural drop
Tilt cylinder - Natural drop
Forks - Color checks of bent area
Truck body frame and cross members - Damage, cracks and loose rivets and bolts

PERIODIC INSPECTION

POWER TRAINS

Checking item	Service Required	Tools	Daily	Monthly (200 hrs)	Trimonthly (600 hrs)	Semiannually (1200 hrs)	Annually (2400 hrs)
Transmission	Check shift levers for operation and looseness.	Operate				○	○
	Check for oil leaks.	Visual	○	○	○	○	○
	Check oil level and change oil if necessary.	Operate				●	●
Front axle	Check for oil leaks.	Visual	○	○	○	○	○
	Change oil.	Visual				●	●
	Check for loose mount bolt.	Visual		○	○	○	○
Transmission box bolts	Looseness (torque 250N)	Test hammer	○	○	○	○	○
	Damage	Visual	○	○	○	○	○

PERIODIC INSPECTION

STEERING SYSTEM

Checking item	Service Required	Tools	Daily	Monthly (200 hrs)	Trimonthly (600 hrs)	Semiannually (1200 hrs)	Annually (2400 hrs)
Tire	Check inflation pressure	Tire gauge	<input type="radio"/>	<input type="radio"/>	<input type="radio"/>	<input type="radio"/>	<input type="radio"/>
	Check for cracks or damage	Visual	<input type="radio"/>	<input type="radio"/>	<input type="radio"/>	<input type="radio"/>	<input type="radio"/>
	Check tread depth	Depth gauge		<input type="radio"/>	<input type="radio"/>	<input type="radio"/>	<input type="radio"/>
	Check for undue wear	Visual	<input type="radio"/>	<input type="radio"/>	<input type="radio"/>	<input type="radio"/>	<input type="radio"/>
	Check for debris, stones or foreign matter in tread	Visual		<input type="radio"/>	<input type="radio"/>	<input type="radio"/>	<input type="radio"/>
Hub, rim mounting bolt, nut	Check for looseness	Test hammer	<input type="radio"/>	<input type="radio"/>	<input type="radio"/>	<input type="radio"/>	<input type="radio"/>
	Check for damage	Visual	<input type="radio"/>	<input type="radio"/>	<input type="radio"/>	<input type="radio"/>	<input type="radio"/>
Rim, side ring	Check rim, side ring , and disk wheel for damage	Visual	<input type="radio"/>	<input type="radio"/>	<input type="radio"/>	<input type="radio"/>	<input type="radio"/>
Wheel bearing	Check for looseness or noise	Touch		<input type="radio"/>	<input type="radio"/>	<input type="radio"/>	<input type="radio"/>
	Disassemble and change grease	Operate				<input checked="" type="radio"/>	<input checked="" type="radio"/>
Axle	Check for deformation, cracks or damage	Visual		<input type="radio"/>	<input type="radio"/>	<input type="radio"/>	<input type="radio"/>

CONTROLS

Checking item	Service Required	Tools	Daily	Monthly (200 hrs)	Trimonthly (600 hrs)	Semiannually (1200 hrs)	Annually (2400 hrs)
Steering wheel	Check for play.	Operate	<input type="radio"/>	<input type="radio"/>	<input type="radio"/>	<input type="radio"/>	<input type="radio"/>
	Check for looseness in axial direction.	Touch	<input type="radio"/>	<input type="radio"/>	<input type="radio"/>	<input type="radio"/>	<input type="radio"/>
	Check for looseness in radial direction.	Touch	<input type="radio"/>	<input type="radio"/>	<input type="radio"/>	<input type="radio"/>	<input type="radio"/>
	Check for proper operation.	Operate	<input type="radio"/>	<input type="radio"/>	<input type="radio"/>	<input type="radio"/>	<input type="radio"/>
Steering gear box	Check for loose mounting bolt.	Operate		<input type="radio"/>	<input type="radio"/>	<input type="radio"/>	<input type="radio"/>
Rod, arm	Check for looseness.	Operate		<input type="radio"/>	<input type="radio"/>	<input type="radio"/>	<input type="radio"/>
	Check for bending, damage or wear	Visual		<input type="radio"/>	<input type="radio"/>	<input type="radio"/>	<input type="radio"/>

PERIODIC INSPECTION

CONTROLS

Checking item	Service Required	Tools	Daily	Monthly (200 hrs)	Trimonthly (600 hrs)	Semiannually (1200 hrs)	Annually (2400 hrs)
Knuckle	Check king pin for looseness or damage.	Touch		○	○	○	○
Rear axle	Check for bending, damage or wear.	Visual		○	○	○	○
	Check mounting condition.	Test hammer		○	○	○	○
Power steering	Check for proper operation.	Operate	○	○	○	○	○
	Check for oil leaks.	Visual	○	○	○	○	○
	Check for loose mounting or linkage.	Visual		○	○	○	○

BRAKE SYSTEM

Checking item	Service Required	Tools	Daily	Monthly (200 hrs)	Trimonthly (600 hrs)	Semiannually (1200 hrs)	Annually (2400 hrs)
Brake pedal	Check for play.	Scale	○	○	○	○	○
	Check for pedal height and returning.	Scale	○	○	○	○	○
	Check for braking or uneven braking.	Operate	○	○	○	○	○
	Check for the entrance of air into braking piping.	Operate		○	○	○	○
	Check booster for proper function and oil leaks (truck with power brake).	Operate		○	○	○	○
Parking brake lever	Check for proper operation and allowance.	Operate	○	○	○	○	○
	Check for braking effect.	Operate	○	○	○	○	○
Rod, cable	Check for proper operation.	Operate		○	○	○	○
	Check for loose linkage.	Touch		○	○	○	○
Hose and pipe	Check for damage, leaks or intervention.	Visual		○	○	○	○
	Check for loose connections or clamp.	Touch		○	○	○	○

PERIODIC INSPECTION

BRAKE SYSTEM

Checking item	Service Required	Tools	Daily	Monthly (200 hrs)	Trimonthly (600 hrs)	Semiannually (1200 hrs)	Annually (2400 hrs)
Oil brake	Check for fluid leaks (oil leaks for trucks with power brake).	Visual		○	○	○	○
	Check fluid level.	Visual	○	○	○	●	●
	Check master cylinder and wheel cylinder for proper operation.	Operate					○
	Check master cylinder and wheel cylinder for oil leaks or damage.	Visual					○
	Check master cylinder, piston cup and check valve for wear or damage, and replace if needed.	Disassembly					●
Brake drum and brake shoe	Check brake drum for loose installation.	Test hammer		○	○	○	○
	Check loose lining.	Vernier calipers					○
	Check brake shoe for operation.	Operate					○
	Check anchor pin for corrosion.	Visual					○
	Check return spring for deterioration.	Scale					○
	Check automatic clearance adjuster for operation.	Operate					○
	Check drum for wear or damage.	Visual					○
Back plate	Check for deformation.	Visual					○
	Check for cracks.	Visual					○
	Check loose installation.	Test hammer					○

PERIODIC INSPECTION

LOAD HANDLING SYSTEM

Checking item	Service Required	Tools	Daily	Monthly (200 hrs)	Trimonthly (600 hrs)	Semiannually (1200 hrs)	Annually (2400 hrs)
Forks	Check for damage, deformation or wear.	Visual	○	○	○	○	○
	Check fork stopper pin for damage or wear.	Visual			○	○	○
	Check for roots and teeth welded area for cracks or wear.	Visual		○	○	○	○
Mast and carriage	Check mast cross members for cracked weld or damage.	Visual		○	○	○	○
	Check tilt cylinder bracket and mast for cracks or damage in welded areas.	Visual		○	○	○	○
	Check outer and inner masts for cracked weld or damage.	Visual		○	○	○	○
	Check carriage for cracked weld or damage.	Visual		○	○	○	○
	Check roller bearing for looseness.	Touch		○	○	○	○
	Check mast support bushing for wear or damage.	Visual					○
	Check mast support cap bolts for looseness.	Torque wrench			○ (first time only)		○
	Check for looseness of lift cylinder tail bolts, piston rod head bolts, U bolts, piston head guide bolts.	Test hammer			○ (first time only)		○
	Check rollers, roller pins and welds for cracks or damage.	Visual		○	○	○	○
Chains and sheaves	Check chains for tension, deformation, damage or corrosion.	Touch	○	○	○	○	○
	Check chains for elongation.	Gauge		○	○	○	○
	Lubricate chains.	Operate		●	●	●	●
	Check loose linkage of chain anchor pin and chain.	Visual		○	○	○	○
	Check sheaves for deformation or damage.	Visual		○	○	○	○
	Check sheave bearings for looseness.	Touch		○	○	○	○
Attachments	Check for operation and installation.	Operate/visual		○	○	○	○

PERIODIC INSPECTION

LOAD HANDLING SYSTEM

Checking item	Service Required	Tools	Daily	Monthly (200 hrs)	Trimonthly (600 hrs)	Semiannually (1200 hrs)	Annually (2400 hrs)
Cylinder	Check piston rod, rod bolt, rod end for looseness, deformation or damage.	Visual/ test hammer	○	○	○	○	○
	Check for proper operation	Operate	○	○	○	○	○
	Check for oil leaks	Visual	○	○	○	○	○
	Check pin and cylinder bushing for wear or damage	Visual		○	○	○	○
Hydraulic pump	Check for oil leaks or noise	Visual & auditory	○	○	○	○	○
	Check drive for wear	Visual & auditory					○

HYDRAULIC SYSTEM

Checking item	Service Required	Tools	Daily	Monthly (200 hrs)	Trimonthly (600 hrs)	Semiannually (1200 hrs)	Annually (2400 hrs)
Hydraulic oil tank	Check oil level and change oil, if contaminated.	Visual	○	○	○	●	●
	Change suction strainer.	Operate				●	●
	Change return filter.	Operate				●	●
Control valve lever	Check for loose linkage of the lever.	Operate	○	○	○	○	○
	Check for function of the lever.	Operate	○	○	○	○	○
Control valve	Check for oil leaks.	Visual	○	○	○	○	○
	Check relief valve and tilt-lock valve for function.	Auditory		○	○	○	○
	Measure relief valve pressure.	Oil pressure gauge				○	○

PERIODIC INSPECTION

ELECTRICAL SYSTEM

Checking item	Service Required	Tools	Daily	Monthly (200 hrs)	Trimonthly (600 hrs)	Semiannually (1200 hrs)	Annually (2400 hrs)
Starter	Check proper engagement of pinion gears	Operate			<input type="radio"/>	<input type="radio"/>	<input type="radio"/>
Charger	Check for proper operation	Ammeter			<input type="radio"/>	<input type="radio"/>	<input type="radio"/>
Battery	Check level and clean	Visual & auditory		<input type="radio"/>	<input type="radio"/>	<input type="radio"/>	<input type="radio"/>
Electrical wiring	Check wire harness for damage and loose clamp	Visual		<input type="radio"/>	<input type="radio"/>	<input type="radio"/>	<input type="radio"/>
	Check for loose connections	touch			<input type="radio"/>	<input type="radio"/>	<input type="radio"/>





PERIODIC INSPECTION

SAFETY DEVICE AND OTHERS

Checking item	Service Required	Tools	Daily	Monthly (200 hrs)	Trimonthly (600 hrs)	Semiannually (1200 hrs)	Annually (2400 hrs)
Overhead guard and load backrest	Check for loose mounting	Test hammer	○	○	○	○	○
	Check for deformation, cracks or damage	Visual	○	○	○	○	○
Turn signal	Check for operation and installation	Operate	○	○	○	○	○
Alarm	Check for operation and installation	Operate	○	○	○	○	○
Lights	Check for operation and installation	Operate	○	○	○	○	○
Back-up alarm	Check for operation and installation	Operate	○	○	○	○	○
Sideview mirrors	Check for contamination or damage	Visual	○	○	○	○	○
	Check for proper visibility	Visual	○	○	○	○	○
Meters	Check for operation	Operate	○	○	○	○	○
Rear reflector/ License number plate	Check for contamination or damage	Visual	○	○	○	○	○
Driver's seat	Check for damage or loose mounting bolts	Visual				○	○
Truck body	Check frame and cross members for damage or cracks	Test hammer					○
	Check for loose rivets and bolts	Visual					○
	Check the results of previous checks	Visual	○	○	○	○	○
	Check general condition of truck	Visual	○	○	○	○	○
Lubricants and oil change	After cleaning, check for lubrication of each part	Grease pump		●	●	●	●
	Check condition of lubricants	Check					○

The following symbols, found throughout this manual, alert you to potentially hazardous conditions to the owner and the operator. Become completely familiar with the truck before proceeding with operating, checking and servicing.

This manual and decals affixed to the truck use the following safety alert indications.

SIGNAL WORD	CLASSIFICATION
 DANGER	Failure to follow the instructions in the message will likely cause a serious accident or death.
 WARNING	Failure to follow the instructions in the message might cause a serious accident or death.
 CAUTION	Failure to follow the instructions in the message may cause personal injury or damage to the truck or other property.
 NOTE	The information will help to prolong the service life of the truck. The message is not directly related to accident prevention.

5.SPECIFICATIONS & SERVICE DATA

CONTENTS

SPECIFICATIONS.....	5 - 2
LOAD CHART.....	5 - 5
SERVICE DAIA.....	5 - 6
AFTER-THE-SALE SERVICE.....	5 - 7
ELECTRICAL SCHEMATIC.....	5 - 8
AFTER-SALES SERVICE.....	5 - 9

SPECIFICATIONS

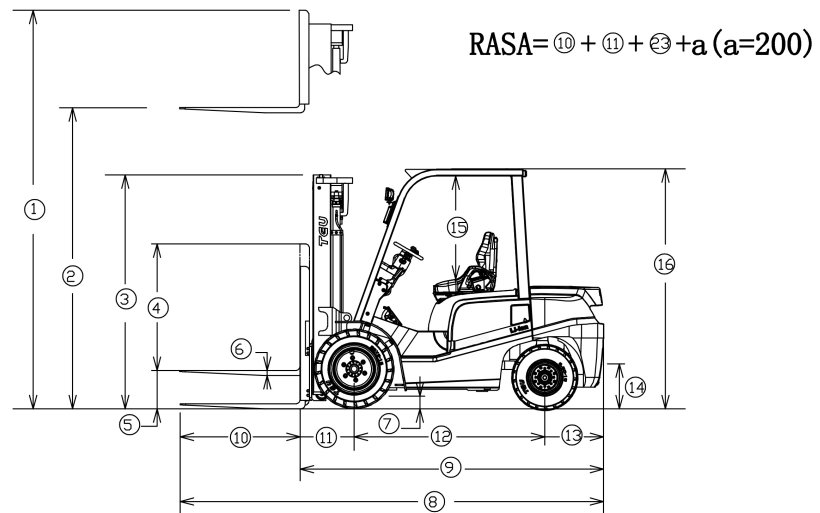
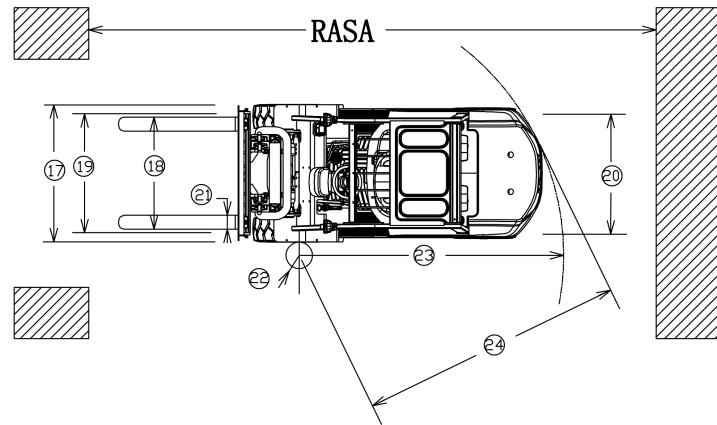

SPECIFICATIONS

SPECIFICATION	1	Manufacturer							
	2	Model			EK20GT-LI	EK25GT-LI	EK30GT-LI	EK35GT-LI	EK40GT-LI
	3	Max.lift capacity		kg/lb	2000/4000	2500/5000	3000/6000	3500/7000	4000/8500
	4	Load center		mm/in	500/24				
	5	Power unit			Lithium Iron Phosphate Battery (LFP Battery)				
	6	Operator type			Driver/Seat				
	7	Tires type	fwd/bwd		Pneumatic				
	8	Wheel(x=driving)	fwd/bwd		2X/2				
DIMENSIONS	9	Max.lift height		mm/in	3000/118				
	10	Free lift		mm/in	160/6.2		150/5.9		
	11	Fork size	L*W*T	mm/in	1070x122x40 / 42.1X4.8X1.5		1070x125x45/42.1X4.9X1.7	1070x125x50/42.1X4.8X1.9	1070x155x50/42.1X6.1X1.9
	12	Tilt angle	fwd/bwd	deg	6/12				
	13	Total length without fork		mm/in	2460/96.8	2530/99.6	2705/106	2760/108	2870/112
	14	Total width		mm/in	1150/45.2		1225/48.2	1285/50.5	1365/53.7
	15	Mast height (fork lowered)		mm/in	1995/78.5		2075/81.6		2125/83.6
	16	Overall height fork raised	with backrest	mm/in	4030/158		4250/167		4250/167
	17	Height of head guard		mm/in	2120/83.4		2140/84.2		2140/84.2
	18	Turning raduis (outside)		mm/in	2170/86.2	2240/88.9	2445/96.2	2495/98.2	2530/99.6
	19	Distance from front wheel center to forks face		mm/in	466/18.3		480/18.8	485/19	485/19
	20	Right angle stacking aisle (excluding goods length and clearance)		mm/in	2615/102	2690/105	2925/115	2975/117	2940/118
PERFORMANCE	21	Max. travelling speed	full load	km/h / mph	20/12.5		20/12.5		
			no load	km/h / mph	20/12.5		20/12.5		
	22	Lifting speed	full load	mm/in/s	480/18.8	460/18.1	425/16.5	380/14.9	380/14.9
			no load	mm/in/s	500/19.6		480/18.8	460/18.1	480/18.8
	23	Lowering speed	full load	mm/in/s	410/16.1	400/15.7	400/15.7	380/14.9	410/16.1
			no load	mm/in/s	450/17.7	450/17.7	420/16.5	400/15.7	400/15.7

LOAD CHART

⚠ CAUTION

The load charts below refer to the lift trucks of standard specifications, and those with high mast whose lifting height is less than 5m, Lift trucks with a high mast whose lifting heights is 5m or higher, or those with an attachment have diferent load charts.

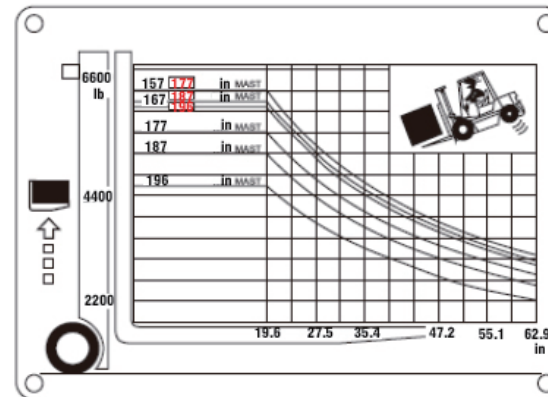
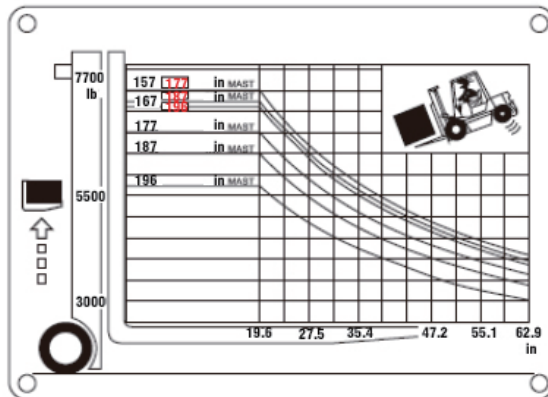
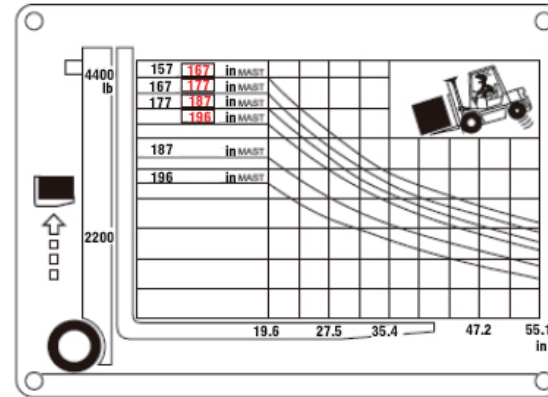
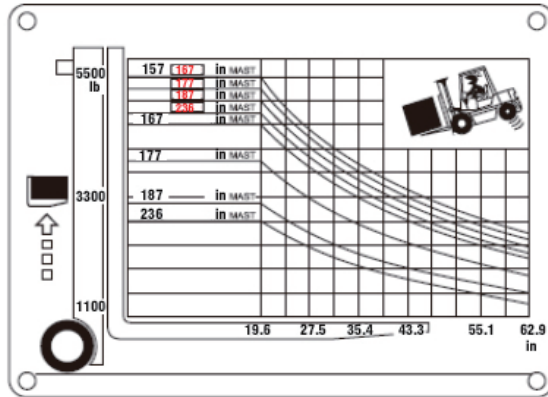

SERVICE DATA

BRAKE PEDAL

Height of brake pedal-----90mm
 Play of brake pedal -----5mm

Parking lever

Basic operating power-----150-170N (15-17kg)

TIGHTENING TORQUE OF BOLTS AND NUTS

Rear axle (axle-frame)
 -----427-634N-m (43.1-64.7 kg-m)
 Mast support (mast-frame)
 -----75-111N-m (7.6-11.3 kg-m)
 Piston head guide mounting bolt
 -----134-200N-m (13.6-20.4 kg-m)

Fuse	Truck model	
F1 (for traveling inverter)	425A	425A
F2 (for hydraulic pump circuit inverter)	425A	425A
F3 (EPS circuit)	50A	50A
F4 (48-V control power supply)	15A	15A
F5 (lamp circuit)	15A	15A
F6 (battery charger output circuit)	15A	15A
F7 (70-V control power supply)		

* For replacement of any fuse is needed, consult your local TEU dealer.

AFTER-THE-SALE SERVICE

SERIAL NUMBERS OF MAJOR COMPONENTS

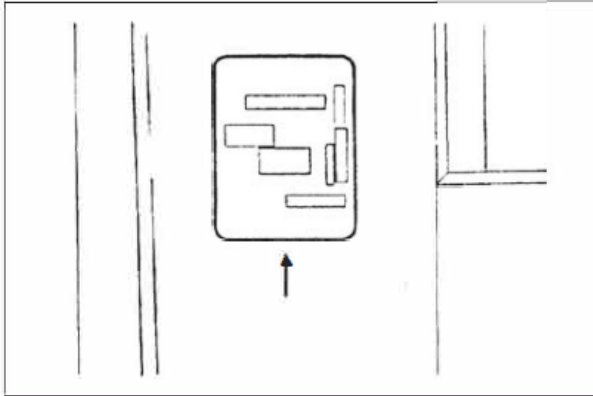

In addition to the truck serial number, the serial numbers (unit numbers) of major components are imprinted on the truck or indicated on decals. The picture above shows the serial number plate of the mast. These number plates should be retained for future reference in servicing.

GENUINE PARTS

However excellent the product is, it deteriorates as used for extended period of time. To ensure the best performance of the lift truck, use the same genuine parts as those used for new trucks.

When ordering spare parts, be sure to designate genuine

GENUINE LUBRICANTS

Use genuine lubricants for lubrication.

ELECTRICAL SCHEMATIC

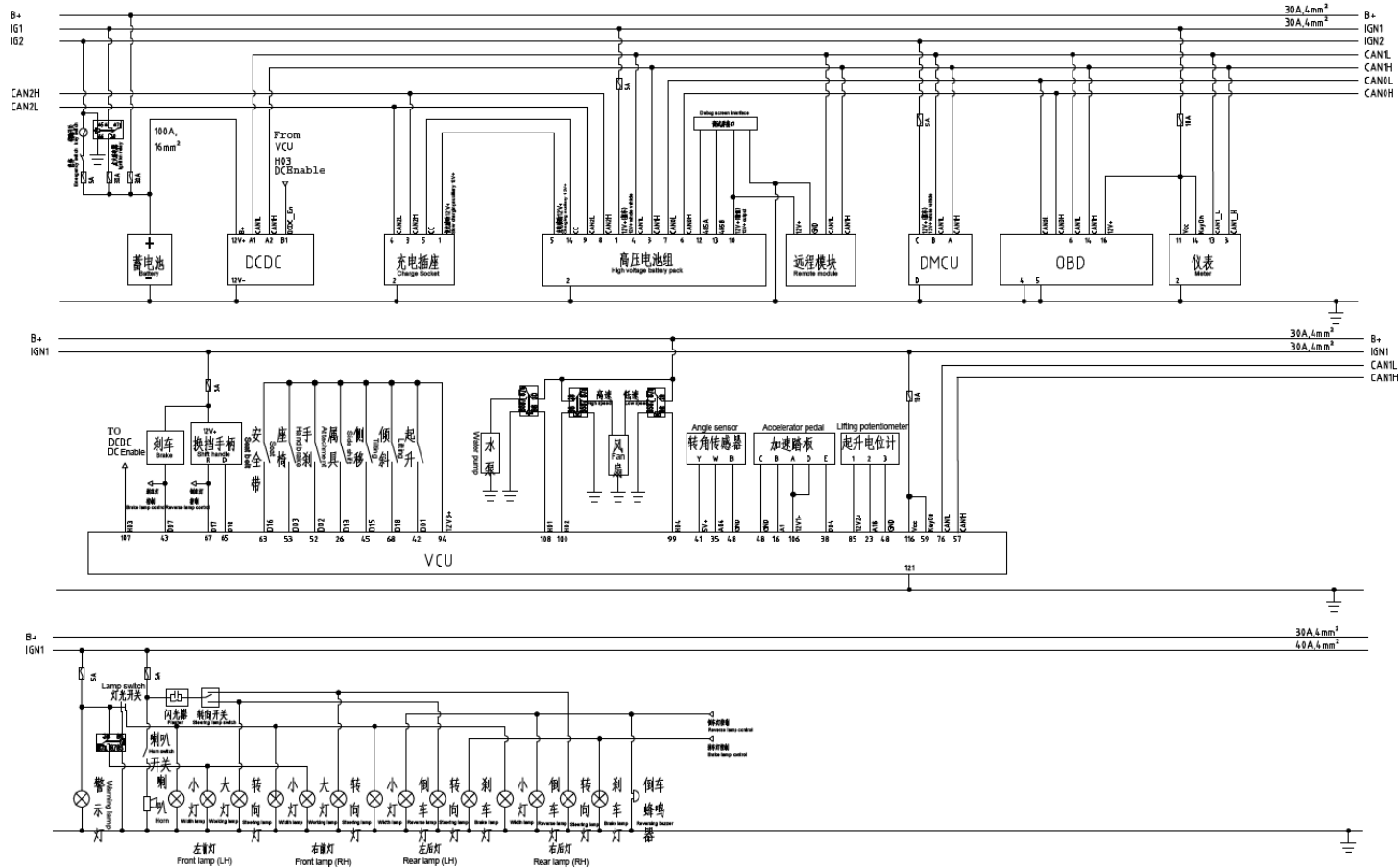

注释 Remark

- 1、高压电池组参照《B48S16SA》
High voltage battery pack reference <<B48S16SA>>
- 2、CAN0--BMS调试CAN, BMS端配置120Ω电阻
CAN0 -- BMS debugging CAN, 120Ω resistance is configured on BMS terminal
- 3、CAN1--整车CAN, BMS及仪表各配置120Ω电阻
CAN1 -- Vehicle CAN, BMS and instrument are equipped with 120Ω resistance
- 4、CAN2--充电CAN, BMS及充电机各配置120Ω电阻
CAN2 -- Charging CAN, BMS and charger are equipped with 120Ω resistors

AFTER-SALES SERVICE

Forklift File

Vehicle Type

Date Of Purchase

Vehicle Manufacture No

Designated Maintenance Factory

Forklift Weight

Max.Loading Weight

Designated Maintenance Factory Tel

Mast Type

Mast Manufactur No

Key No

Vehicle Management No

Vehicle Manager

Attachments

Operating License No

Date Of Delivery