



Operations & Maintenance Manual

4 Wheel Lithium Forklift

T-LI Series

EK25T-LI / EK40T-LI



Instructions for use

Please read this manual carefully and operate the vehicle safely.

- Do not operate this vehicle without training.
- Please comply with ISO3691 “Safety Specification for Motor Vehicles Industry”.
- Please do not modify or change the repair parameters, including adjusting the pressure. Any loss or damage to the vehicle resulting from such actions will be your responsibility, and doing so will void our warranty commitment.

SPECIAL WARNING:

The company is committed to innovation and sustainable development. As part of this commitment, we continually improve the technology of our products. Therefore, we reserve the right to make changes and improvements to any product described in this specification without prior notice.

Safety Alert Indications

This manual and the safety decals on the forklift use the following signal words to indicate the level of hazard and the potential consequences of improper operation.

Signal Word Classification

⚠ DANGER Failure to follow these instructions will likely cause serious injury or death.

⚠ WARNING Failure to follow these instructions might cause serious injury or death.

⚠ CAUTION Failure to follow these instructions may cause personal injury or damage to the forklift or property.

📄 NOTE This information helps prolong the service life of the forklift. It is not directly related to accident prevention.

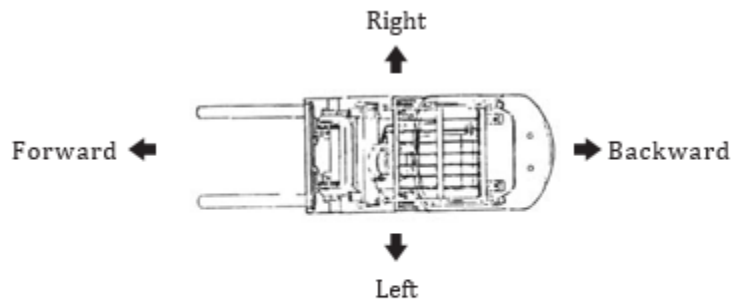

The diagram above defines the directional terms "forward", "backward", "right" and "left" as used throughout this manual.

FOR SUPERVISORS

Forklift accidents cause numerous injuries and fatalities each year. Although modern forklifts are designed with safety in mind, accidents still occur due to improper operation, inadequate training, unsuitable equipment selection, or unsafe working conditions.

Supervisors play a critical role in preventing accidents by:

- Ensuring operators are properly trained and authorized
- Selecting the correct equipment and attachments for the job
- Maintaining safe operating environments
- Enforcing safe work practices at all times

Proper and Improper Use of the Forklift

Proper Use

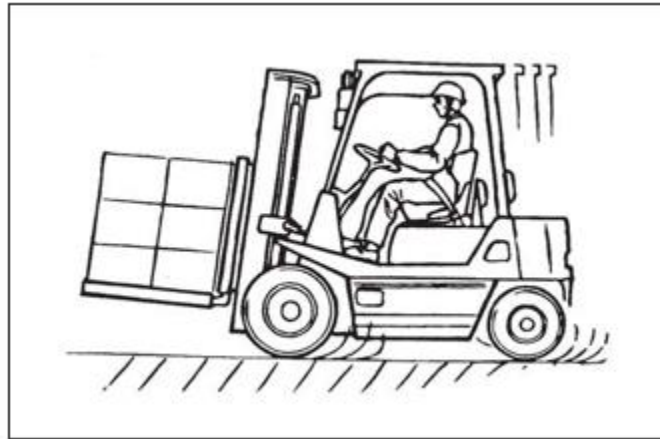

A forklift is designed for lifting, transporting, and stacking materials that are placed on pallets or other approved load-handling platforms.

When equipped with an approved attachment, the forklift may also handle loads positioned outside of a pallet, provided the attachment is suitable for the task and installed correctly.

Proper use includes:

- Handling loads that are stable, secured, and within the rated capacity.
- Using only approved attachments designed for the intended load.
- Operating the forklift on surfaces suitable for safe travel.
- Following all safety instructions, decals, and workplace rules.
- Keeping loads within the recommended height limits during travel.

Improper Use

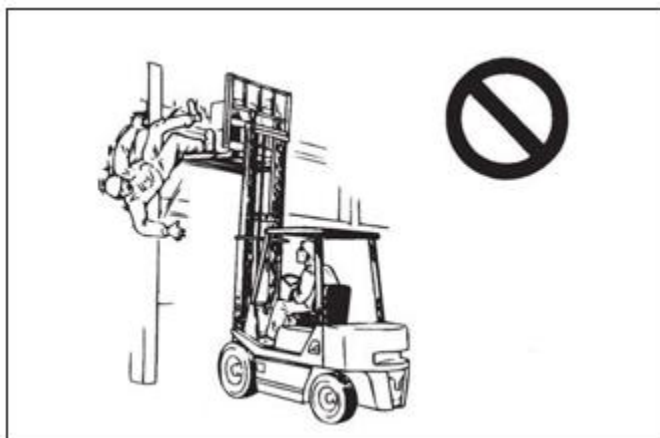

Any use of the forklift outside of its intended purpose is unsafe and must not be permitted. Improper use can lead to equipment damage, loss of load, or serious injury.

Examples of improper use include:

- Transporting or elevating a person on the forks, pallet, or load.
- Allowing a person to ride on the forklift for any reason.
- Using the forks to push, pull, pry, or open doors.
- Suspending loads from the forks using chains, cables, or slings.
- Towing or pushing another vehicle or piece of equipment.
- Using the forklift as a work platform without an approved personnel-lifting device.
- Operating the forklift with removed, disabled, or modified safety devices.
- Using damaged pallets or unstable load bases.

Supervisor Responsibility

Supervisors must ensure that operators understand the difference between proper and improper use and enforce safe practices at all times.

Improper use must be corrected immediately to prevent accidents and maintain a safe working environment.

Planning and Working Area

Make an Operating Plan and Discuss It

Before beginning forklift operations, plan the travel routes and work procedures. Review the plan with all personnel involved to ensure everyone understands the operating area, traffic flow, and safety precautions.

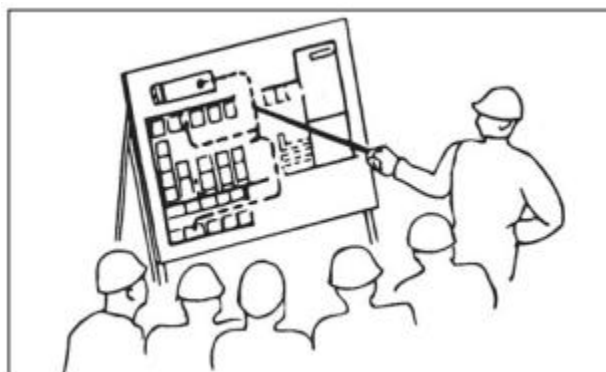

Before beginning forklift operations, plan the travel routes and work procedures. Review the plan with all personnel involved to ensure everyone understands the operating area, traffic flow, and safety precautions.

Set Speed Limits

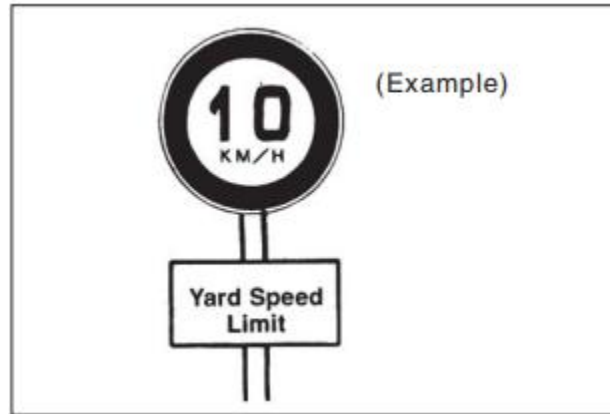

Establish safe speed limits for all forklift operations. Speed limits should reflect the conditions of the work area, including surface type, visibility, pedestrian activity, and congestion. Post clear signs showing the maximum permitted speed.

Install Curbs or Railings



If forklifts are used on loading docks, elevated platforms, or near edges, install curbs, guardrails, or other protective barriers. These measures help prevent accidental falls and protect both operators and equipment.

Mark the Travel Lanes

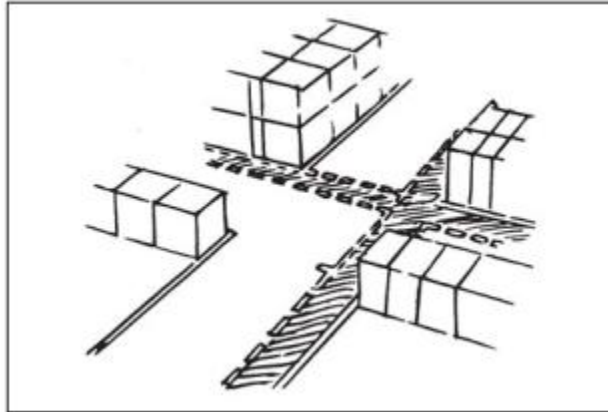

Designate and clearly mark travel lanes for forklifts. Separate pedestrian walkways from vehicle routes whenever possible. Use floor markings, barriers, or signage to maintain safe and organized traffic patterns.

Keep People Out of the Operating Area



Only authorized personnel should be allowed in areas where forklifts are operating. If other workers must be present, assign a trained guide to ensure pedestrians remain clear of moving vehicles. Post signs or barriers to mark restricted zones.

Keep Unauthorized Vehicles Out

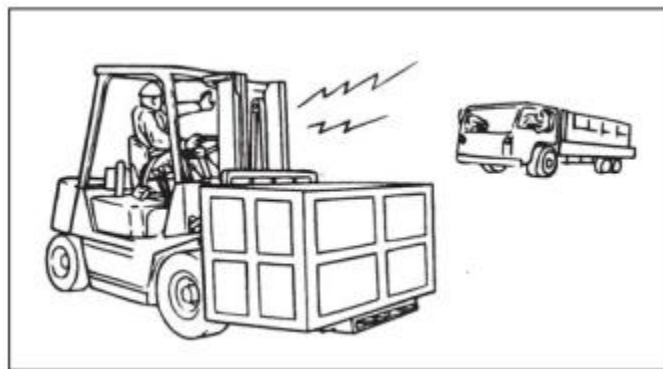

Restrict access to load-handling areas to authorized vehicles only. Use signage, cones, or signals to prevent other vehicles from entering forklift operating zones.

Keep the Ground Level and Dry

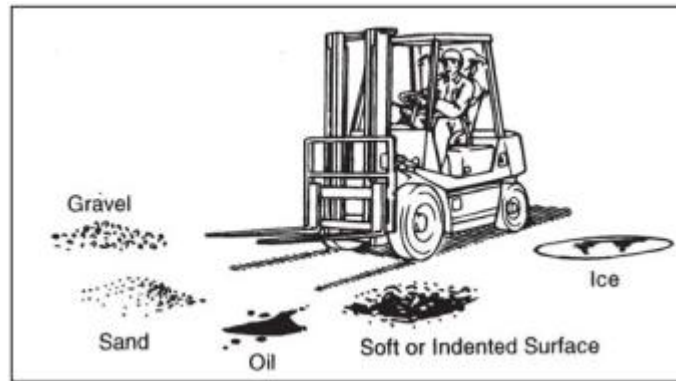

Ensure all travel surfaces are level, firm, and free of hazards. Remove oil, water, ice, or debris that could cause slipping or loss of control. Avoid operating on soft or uneven ground whenever possible.

Provide Adequate Lighting

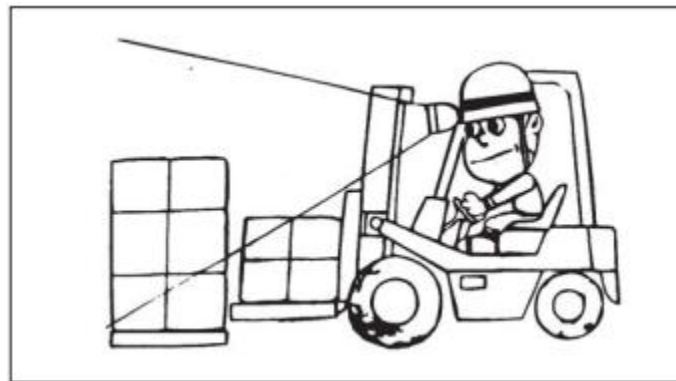

Safe operation requires well-lit travel routes so pedestrians, obstacles, and loads are clearly visible. Use headlights, taillights, and auxiliary lighting as needed to maintain visibility in dim or enclosed areas.

Assign Traffic Guides to Congested Areas



In confined or congested areas where people or other vehicles may pass, assign a trained traffic guide to direct movement safely. All personnel must follow the guide's instructions to prevent collisions and maintain smooth traffic flow.

Know Who to Call in an Emergency

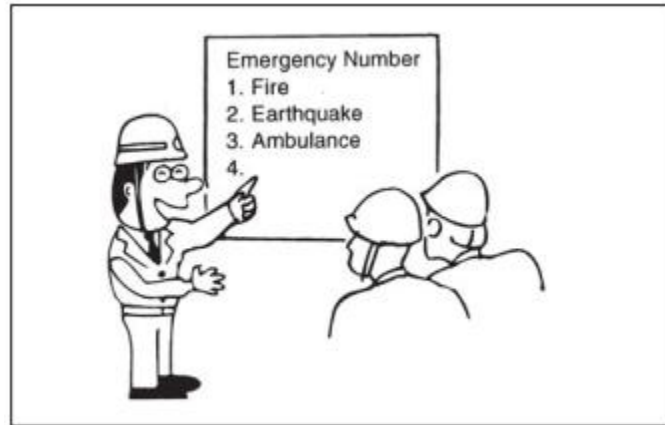

Keep emergency contact information posted and easily accessible. Include numbers for fire, medical assistance, and other relevant services. Ensure all personnel know how to report emergencies quickly and accurately.

Proper Use of Emergency Equipment



Fire extinguishers and first-aid kits must be provided, inspected regularly, and kept in clearly marked locations. All personnel should be familiar with the location and proper use of emergency equipment.

Safety Measures for Danger Spots



Identify areas with potential hazards and mark them clearly with warning signs or barriers. Take additional precautions—such as restricted access or protective equipment—where risks cannot be eliminated.

Traveling on Public Roads

Got a License?



Before operating a forklift on public roads, ensure the vehicle has been properly licensed and inspected according to local regulations. Only trained and authorized operators may drive forklifts outside company property.

No Load, No Towing



Carrying loads or towing other vehicles on public roads is generally prohibited. Do not transport materials or tow another vehicle except in emergencies involving a disabled vehicle. Never tow or push another vehicle, even within company premises, unless specifically authorized and equipped for that purpose.

Obey Traffic Laws and Turn Off Work Lights

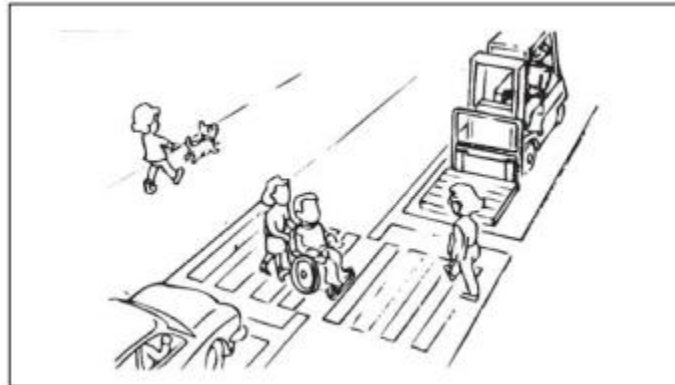

When traveling on public roads, forklifts must comply with all traffic laws and regulations, just like any other vehicle. Use turn signals and headlights as required by law, but turn off rear work lights or auxiliary lamps that may distract other drivers. Operate with caution near pedestrians, crosswalks, and intersections.

Operator Safety and Fitness

Wear Protective Gear

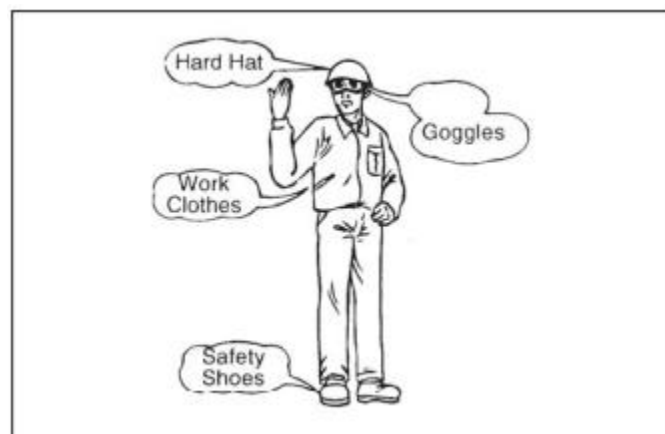

Always wear proper work clothing when operating a forklift. Work clothes should be designed to prevent any part from catching on controls, knobs, or other equipment components. Shirts and trousers should have snug cuffs and fit securely.

Required protective gear includes:

- **Hard hat** – protects against falling objects or overhead hazards.

- **Safety shoes** – prevent foot injuries from dropped materials or equipment.
- **Work clothes** – durable, fitted garments that reduce snagging risks.
- **Additional protective gear** – such as goggles, gloves, or hearing protection, depending on worksite conditions.

Train Your Staff to Stack Safely

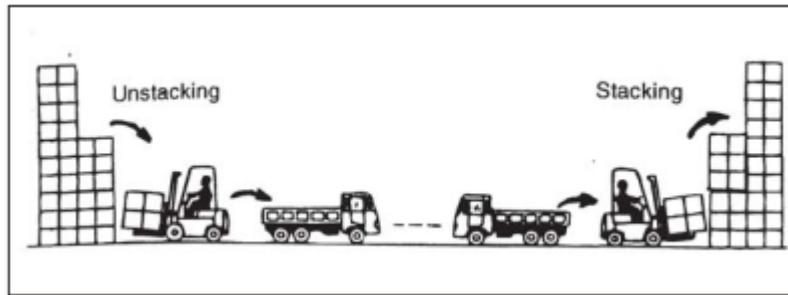

“Stacking” means placing palletized loads or materials directly on top of each other without racks or shelves for separation. If stacking is done improperly, loads may slip or fall, creating a serious hazard for operators and nearby personnel.

Safe stacking practices include:

- Ensuring loads are stable and evenly distributed.
- Avoiding excessive height that could compromise balance.
- Using pallets and materials in good condition.
- Keeping the stacking area clear of obstructions.

All operators should receive training in proper stacking and unstacking methods. Safety instruction should emphasize load stability, visibility, and awareness of surrounding personnel.

Tired or Unwell? Send Them Home



Never allow an operator to work while fatigued, ill, or under the influence of alcohol, drugs, or medication that impairs judgment or reaction time. Operating a forklift requires full attention and coordination. Supervisors must ensure that only alert, capable personnel are permitted to operate equipment.

Types of Vehicles and Loads

Use the Right Forklift for the Job

Always ensure the type and capacity of the forklift are suitable for the work environment and load requirements.

Check Point Guidelines

Capacity	Forklift capacities range widely. Always verify the rated capacity and load center before use. Never exceed the manufacturer's specified limits.
Power Source	Forklifts may be powered by gasoline, diesel, natural gas, or battery. Choose the power source appropriate for the environment—battery-powered units are preferred for indoor or enclosed areas.
Balance	Counterbalanced forklifts use a rear counterweight for stability. Reach trucks extend the mast forward for loading and unloading in tight spaces. Select the design that best fits your workspace.
Tires	Use solid or cushion tires for indoor operations and pneumatic tires for outdoor surfaces. Solid cushion tires may be used where punctures are likely. Always inspect tires for wear and damage.
Flammable Materials	When handling flammable or combustible materials, use only forklifts with explosion-proof or safety-reinforced construction. Electric models provide better protection against fire hazards than combustion engines.

Use the Proper Attachment

Attachments expand forklift capability but must be used correctly and safely. Common examples include:

1. **Roll Clamp** – for paper rolls or drums
2. **Rotating Fork** – for dumping or charging work
3. **Hinged Fork** – for lumber handling
4. **Side Shift** – for precise stacking in narrow spaces

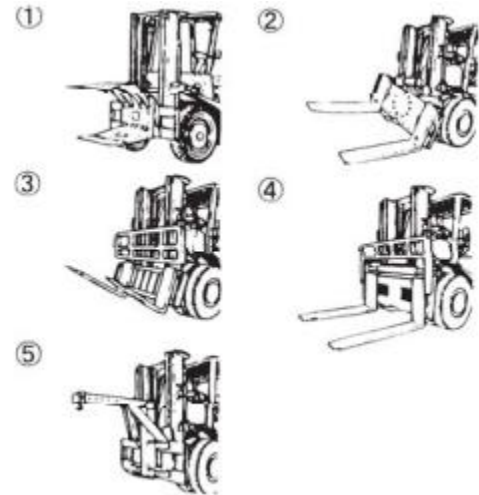

5. **Crane Arm** – for slinging or lifting suspended loads

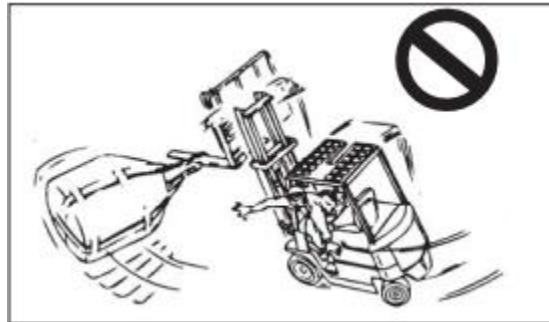

⚠ Warning

Never hoist a load using wire rope or chains hung directly from the forks or an attachment. Do not lift freight containers with forks unless specifically designed for that purpose. Improper lifting can cause the forklift to tip over. If suspended lifting is required, have a qualified operator use a hook or crane arm attachment.

Equipment Safety and Modifications

No Operation Without Lights, Overhead Guard, or Load Backrest



A forklift must not be operated if any essential safety components have been removed or are not functioning. These include headlights, taillights, overhead guard, load backrest, horn, and turn signals. If any part has been temporarily removed for maintenance or repair, it must be reinstalled before the forklift is used.

Do Not Rely on the Overhead Guard



The overhead guard is designed to reduce the impact of small falling objects, but it cannot withstand heavy impacts. Never assume the guard will fully protect against large or heavy items. If there is a risk of falling materials, take preventive measures to secure the load or adjust the work area to eliminate the hazard.

Obtain Approval for Any Modification



Do not modify or alter the forklift's structure, capacity, or components without written approval from the manufacturer. Unauthorized modifications can compromise safety and void equipment certification. Examples include adding counterweights, changing mast height, or altering electrical systems. Always consult the manufacturer or authorized service provider before making any changes.

Use Sturdy Pallet Materials

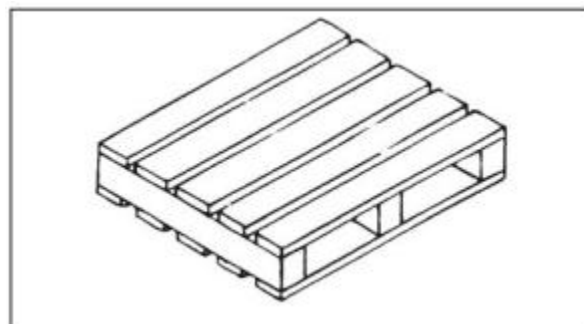

Pallets and skids must be strong enough to support the full weight of the load. Inspect pallets before use and remove or repair any that are cracked, broken, or weakened. Using damaged pallets can cause load instability and accidents.

Stack Loads Securely

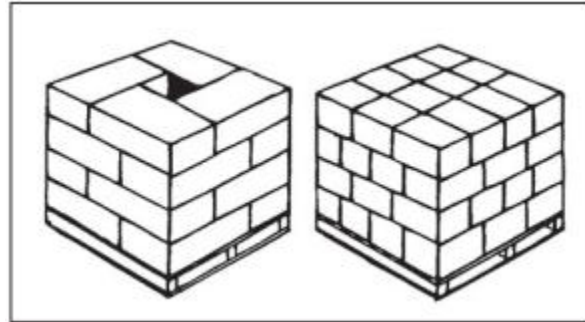

When stacking loads, arrange them in a stable, interlocking pattern to prevent shifting or collapse. Ensure the weight is evenly distributed across the pallet. Secure the top layer with strapping, shrink wrap, or other suitable restraints to keep the load intact during movement.

Know the Load-Bearing Capacity of the Floor



Forklifts are heavier than they appear. For example, a 2-ton forklift may weigh over 3 tons when empty, and when loaded, up to 90 percent of the total weight is concentrated on the front wheels. Before operating, verify that floors, ramps, and roadways can safely support the combined weight of the forklift and its load. Reinforce weak areas if necessary to prevent structural damage or collapse.

Inspection and Maintenance

Always Inspect Before Operating

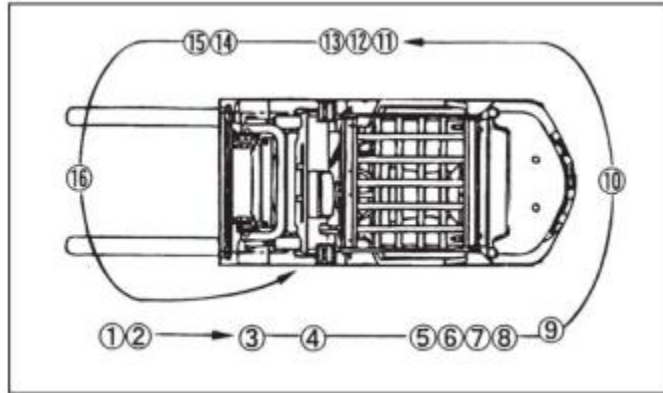

Before each use, the operator must inspect the forklift to ensure all safety features and components are functioning properly. Any irregularities or damage must be reported immediately to a supervisor, who is responsible for arranging repairs. Never operate a forklift that shows signs of malfunction or missing safety equipment.

Periodic Inspections Are Mandatory

Comprehensive inspections must be performed monthly and annually by certified personnel with the proper tools and training. All defects must be repaired promptly. Inspection records should be maintained and preserved for at least three years to ensure compliance and traceability.

Replace Safety Parts Regularly

Certain critical parts must be replaced at scheduled intervals, even if no visible wear is detected. Failure to replace these components can lead to serious accidents or equipment failure.

Safety Part	Recommended Replacement Interval (Years)
Cups and dust seals of master cylinder and wheel cylinders	1
Power steering hose	2
Reserve tank tubing	2-4
Steering actuator rubber boots	2
Lift chain	2-4
Load-handling hoses	1-2

Never Use an Unmaintained Forklift

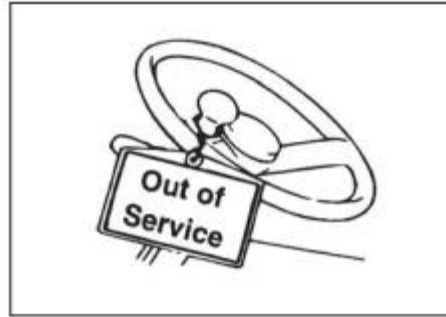

A forklift that has not passed inspection must not be operated. Tag the equipment “**Out of Service**” and remove the ignition key to prevent unauthorized use. Report the issue to a supervisor and wait until repairs are completed and the forklift is cleared for operation.

Inspection and Transporting the Forklift

Designate a Repair and Assembly Supervisor

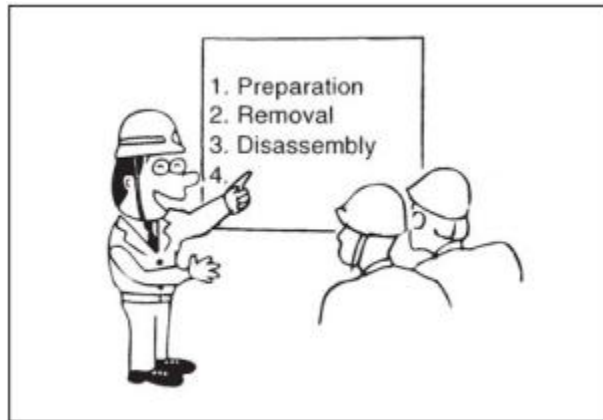

All repair, assembly, and attachment work must be performed under the supervision of a designated, qualified individual. Forklift components are heavy and may be under high pressure. Unsupervised or improperly prepared repair work can result in serious injury. Ensure all personnel involved understand the procedures for preparation, removal, and disassembly before beginning work.

Transporting the Forklift

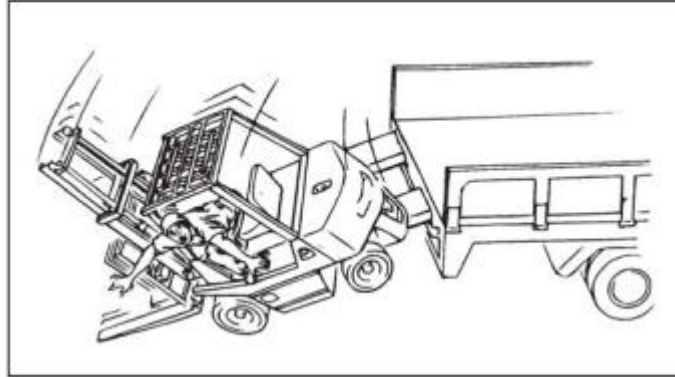

When loading or unloading a forklift onto a trailer, always use a level, hard surface. Confirm that loading ramps are strong enough and wide enough to support the forklift's weight. Avoid loading or unloading during rain unless ramps have anti-slip surfaces.

Safe loading practices:

- Use a self-loading trailer equipped with a jack and winch when possible.
- For loading, tilt the pallet with the jack, attach the winch to the towing pin, start the engine, and pull the forklift up slowly.
- Never ride on the forklift while it is being loaded or unloaded.

How the Forklift Works

Keep People Out of the Operating Area

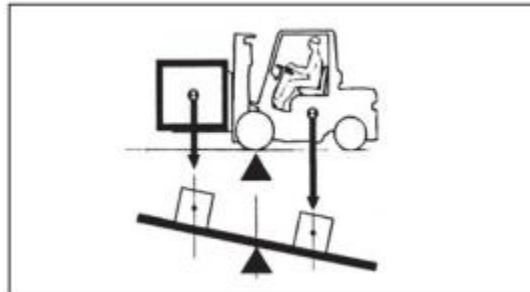

Forklifts use a mast and forks at the front to lift and carry loads. The front wheels act as a fulcrum, balancing the center of gravity of both the truck and the load. Understanding how these two centers of gravity interact is essential for safe operation. Always keep personnel clear of the operating area to prevent accidents caused by shifting loads or sudden movements.

Know the Center of Gravity of Your Load

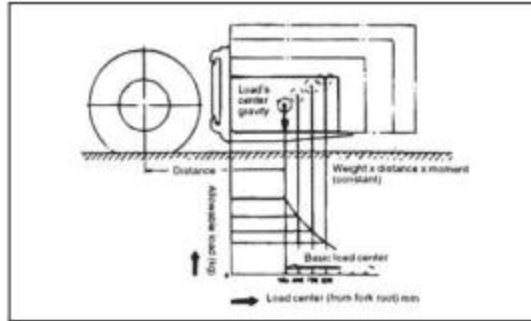

Different materials—boxes, flat items, or cylindrical objects—affect the center of gravity in unique ways. Operators must know where the center of gravity lies for each load type to maintain stability. Improperly balanced loads can cause tipping or loss of control. Ensure the load is positioned evenly on the forks and secured before lifting or moving.

How the Center of Gravity Shifts

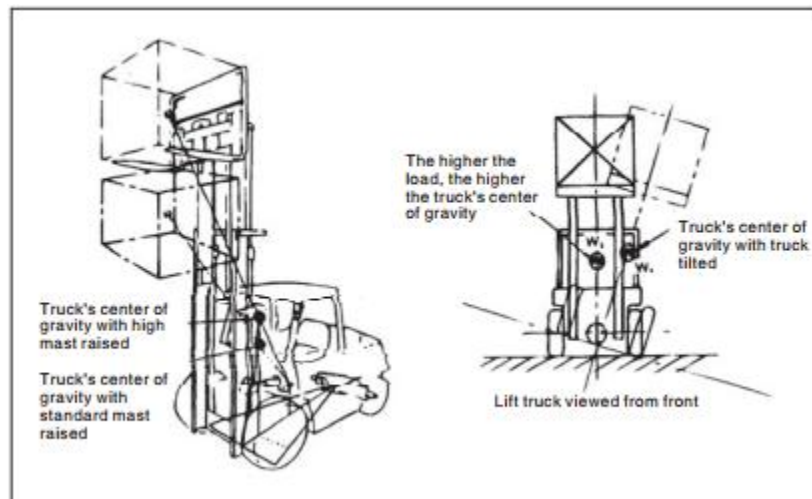

The forklift's overall stability depends on its combined center of gravity—the balance point between the truck and the load. When the truck is empty, the center of gravity lies within the vehicle itself. When loaded, it shifts forward toward the load. Raising or tilting the mast changes this balance, increasing the risk of tipping.

Factors affecting the center of gravity include:

- Size, weight, and shape of the load
- Height of the lift or unloading position
- Tilt angle of the forks
- Tire inflation and condition
- Acceleration, deceleration, and turning

- Surface condition and slope
- Type of attachment used

The higher the load or the more the mast is tilted, the higher and farther forward the center of gravity moves—reducing stability. Operators must adjust speed and mast position accordingly to maintain control.

Understanding Forklift Stability and Load Rating

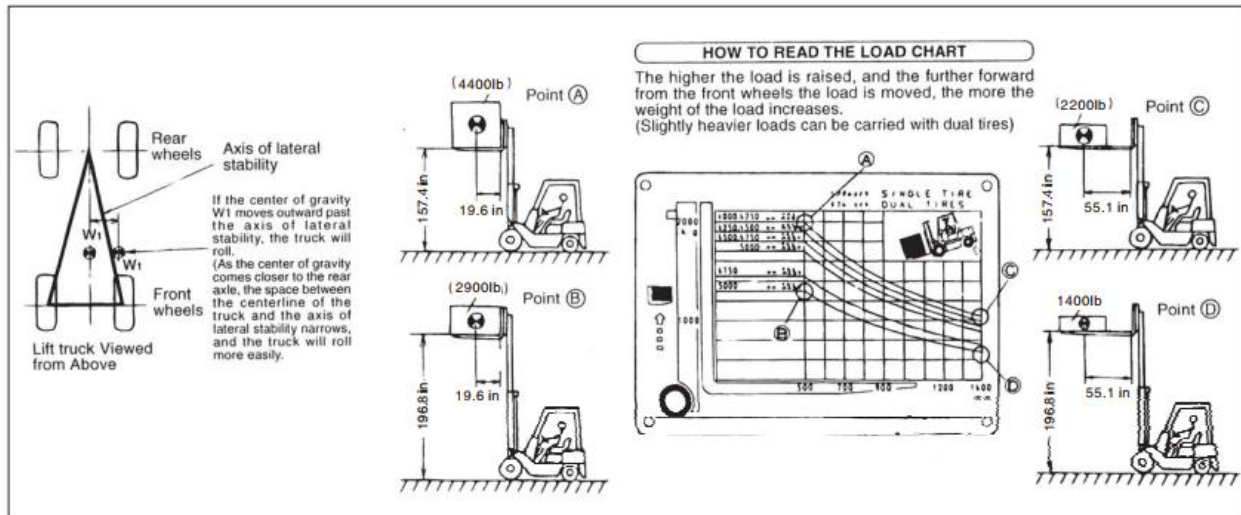

Outside the Triangle of Balance – The Truck Tips

For a forklift to remain stable, its overall center of gravity must stay within the **stability triangle** formed by the contact points of the left and right front tires and the center point between the rear steering wheels. This triangle defines the safe zone for the center of gravity.

If the center of gravity moves forward beyond the front wheels, the forklift will tip forward, using the front wheels as a pivot. If it moves outside the triangle to either side, the truck will roll in that direction. Maintaining the center of gravity within this triangle is essential for preventing tip-overs and ensuring safe operation.

Rated Load (Load Weight and Load Center)

The **load center** is the horizontal distance from the front face of the forks to the load's center of gravity. The **rated load** is the maximum weight that can be safely lifted at the nominal load center, as specified by the manufacturer.

A **load chart** is attached to each forklift, showing how rated capacity changes with load center and lift height. As the load center moves farther forward or the mast is raised, the rated capacity decreases because the center of gravity shifts forward.

Key points:

- Heavier loads can be handled only when the load center is close to the mast.
- Raising the load or extending the forks reduces stability and allowable weight.
- Always consult the load chart before lifting to confirm safe limits.

Accelerating, Decelerating, and Turning

The principle of **inertia** states that an object at rest remains at rest and an object in motion continues moving at a constant speed unless acted upon by an external force.

This principle directly affects forklift stability during acceleration, braking, and turning.

Acceleration and Braking

When a forklift begins to move, inertia creates a momentary backward force.

When it stops, inertia produces a forward force.

If brakes are applied suddenly, the forward momentum can cause the forklift to tip forward—especially when carrying a raised load.

Always apply brakes smoothly and gradually to maintain control.

Turning

During turns, **centrifugal force** pushes the forklift outward from the center of rotation.

This outward force can cause the truck to tip sideways if speed is too high or the load is elevated.

Because the zone of lateral stability is narrow, operators must reduce speed significantly when turning, particularly with raised loads.

Elevated Loads

When the load is lifted, the overall center of gravity rises, reducing stability.

A high center of gravity increases the risk of tipping forward or sideways during sudden stops or sharp turns.

Operate slowly and cautiously whenever the mast is raised.

Traveling

⚠ Read Manual and Decals

Always read the **Operation and Maintenance Manual** and all caution plates on the forklift before use. Each model may differ in design and operation. Familiarize yourself with all safety decals and keep the manual accessible for anyone who operates or services the truck.

⚠ When Starting

Before turning the key switch on:

- Apply the parking brake securely.

- Place the forward/reverse lever in neutral.
- Press the brake pedal.
- Adjust the steering column and seat to a comfortable position.

Never adjust these during operation. Ensure no one is near or under the truck before seating yourself in the driver's position.

⚠ Before Reversing Direction

Always bring the forklift to a complete stop before changing direction. Abrupt reversal can cause mechanical damage or loss of control.

⚠ Carry the Load Low

Travel with the forks as low as safely possible, regardless of whether the truck is loaded. Do not turn with the load raised—this increases the risk of tipping.

⚠ Keep the Truck's Center of Gravity Low While Traveling

When loaded, keep the forks approximately 7–8 inches above the ground and tilted slightly back. This helps maintain a low center of gravity and improves stability.

⚠ Do Not Jerk the Forks When Loaded

Avoid sudden lifting, lowering, or tilting movements. Abrupt actions can cause the truck to tip forward or lose load stability.

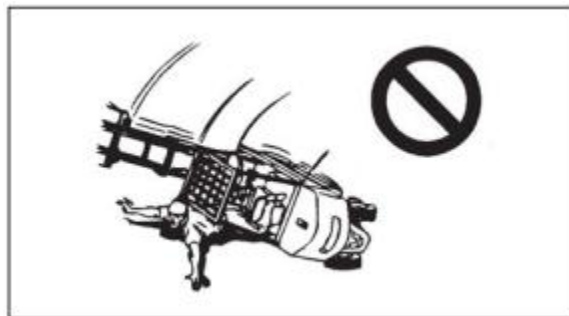

⚠ Avoid Sharp Starts, Stops, and Turns

Operate smoothly. Reduce speed before turning, especially when the truck is unloaded—its rear weight can cause instability. Gradual acceleration and braking help maintain control and prevent tipping.



⚠ Back Down and Drive Up on a Slope

- Never make turns on a slope — this can cause the forklift to tip.
- Keep forks and pallets at a safe ground-clearance height.
- When operating **unloaded**, keep the rear of the truck pointed uphill.
- When operating **loaded**, keep the rear of the truck pointed downhill.
- Use foot and regenerative brakes properly when descending.
- Never turn off the key switch while descending a grade.

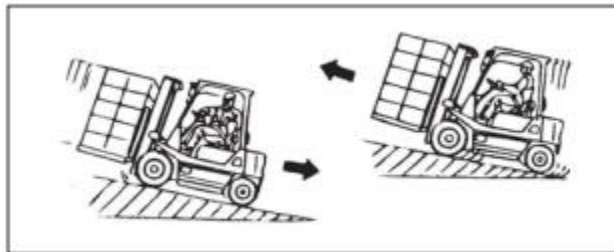

⚠ Stay Away from the Edge of the Road

Avoid operating near the edge of soft or unstable ground, as it may collapse. Maintain a safe distance from the edge of narrow roads, ramps, or platforms to prevent accidents.

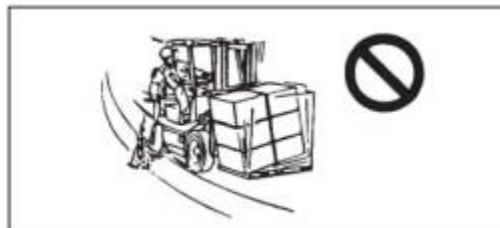

⚠ When Driving Over a Dockboard or Bridgeplate

- Do not ride on the edge of a dockboard or bridgeplate — the truck could fall, causing serious injury or death.
- Ensure the dockboard or bridgeplate is properly secured and undamaged.

- Never exceed its rated capacity.
- Set the trailer brakes and block the wheels to prevent movement.
- Install jacks to support the trailer when entering with the forklift.

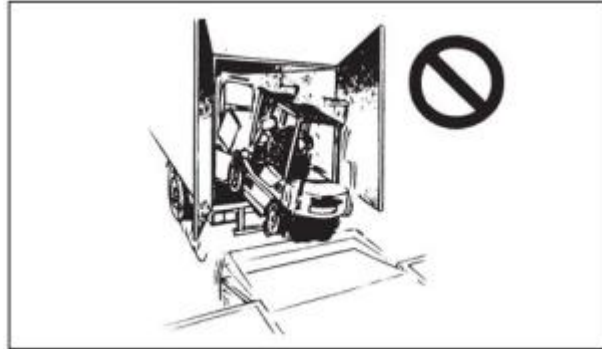

- Drive slowly and carefully across the dockboard or bridgeplate.
- Watch for bystanders and instruct the trailer driver not to move until loading or unloading is complete.
- Always confirm the dockboard or bridgeplate is secure before crossing.

⚠ Never Use a Person as a Counterweight

Never use a person as an additional counterweight or allow anyone to ride on the forklift. Doing so can cause severe injury or death.



⚠ Have a Guide When Handling Bulky Loads

When handling large or bulky loads that obstruct your view, operate the forklift in reverse and use a trained guide to direct movement. Maintain clear communication with the guide at all times.

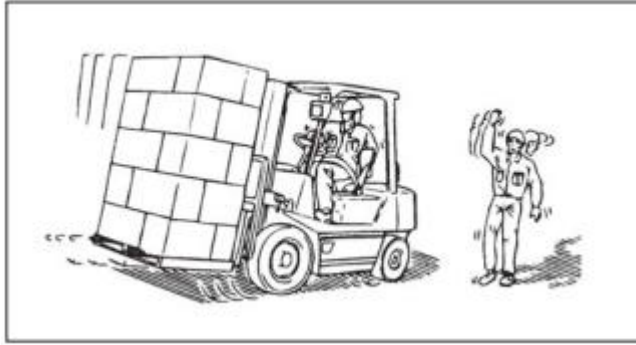

⚠ Reverse Travel

When traveling in reverse, always look in the direction of travel. Do not rely solely on mirrors or backup alarms. Turn your head and check surroundings to ensure a clear path.

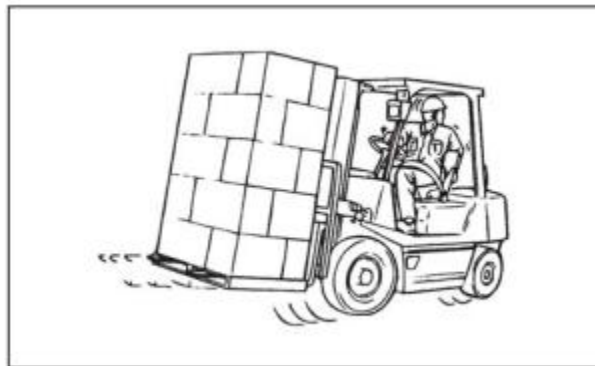

⚠ Pre-Operational Checks

Do not begin work until all pre-operational inspections are complete. If any issue is found, report it immediately to your supervisor and do not operate the forklift until repairs are made.

⚠ Keep Mirrors, Backup Alarm, and Lamps in Good Condition

- Adjust mirrors for full rear visibility and keep them clean.
- Ensure the backup alarm sounds when the forklift is in reverse.
- Replace burned-out bulbs and repair any malfunctioning lights or alarms before operating.

⚠ Keep Your Hands Clean

Operating controls with greasy or dirty hands can cause slippage and loss of control. Clean hands thoroughly before handling the steering wheel or levers.

⚠ Mount Properly

Never mount or dismount a moving forklift. Always bring the truck to a complete stop before getting on or off. Use designated steps and hand grips for support, and keep them clean and free of oil or debris.

⚠ Do Not Move Controls Unless Properly Seated

Operate levers and pedals only when seated correctly. Standing or leaning while operating controls can cause loss of balance or control.



⚠ Sound Horn When Starting

Before starting, ensure no one is near the forklift. Sound the horn to alert nearby workers and bystanders that the truck is about to move.



⚠ Do Not Turn the Key Switch Off While Moving

Turning off the key switch disables power steering, making it difficult to control the truck. Always keep the power on while operating.

⚠ Safe Traveling

- **Always look in the direction of travel.** Failure to do so can lead to collisions or accidents.
- When passing another truck, slow down and maintain a safe distance.

- Keep a clear area around the forklift and ensure no obstacles are in your path or turning radius.
- **Observe speed limits** and adjust speed according to workplace conditions.



- **Do not pass other trucks** at intersections, corners, or areas with restricted visibility.
- **Slow down at corners** and sound the horn when approaching intersections or blind spots.
- **Come to a complete stop** before crossing roads or turning at corners.

⚠ Do Not Travel Over Wet or Soft Surfaces



Avoid driving over floors or ground covered with water, potholes, or soft soil. Wet or unstable surfaces can cause loss of traction and tipping. If unavoidable, proceed slowly and cautiously.

⚠ Do Not Ride on Obstacles

Avoid crossing curbs, railroad tracks, or ditches. If crossing is unavoidable, reduce speed and maintain control.

⚠ Avoid Running on Slippery Surfaces

Operate slowly and carefully on wet, oily, or icy floors. Sudden acceleration or braking can cause skidding.

⚠ Know the Load-Bearing Capacity of the Floor

Before entering a building, elevator, or platform, confirm that the surface can support the combined weight of the forklift and its load. Never assume structural strength without verification.

⚠ When Entering Areas With Height or Width Limits

- Ensure sufficient clearance for the forklift to pass safely.
- Keep hands and feet inside the operator's compartment.
- Confirm no one is near the truck.
- Watch for overhead cables, beams, or other obstacles.

⚠ Rear Steer and Rear Swing

When turning forward, the rear of the forklift swings outward. Always check for walls, racks, or other obstacles before turning.

⚠ Brake the Truck in Good Time

Forklifts require longer stopping distances on slippery or downhill surfaces. Brake early and maintain a controlled speed to prevent sliding or loss of control.

⚠ Practice Safe Driving and Load Handling

Before operating, practice safe driving and load handling techniques. Even experienced operators must remain cautious—reckless driving or improper handling can cause injury or damage.

⚠ When Using Multiple Trucks

Different forklifts may have unique control layouts or braking systems, even if they appear similar. Review each truck's controls before operation and pay special attention to braking performance.

Load Handling

⚠ WARNING

Never overload
Know the rated capacity of your lift truck and its attachment, if any, and never exceed it; otherwise the rear wheels will be raised, thus making it difficult to travel and turn. There is also danger of the truck tipping over.

Never lift a load over anyone
Never permit anyone to stand under raised forks. The forks might fall down unexpectedly, thus causing a personal injury.

Never elevate a man
Never allow other person(s) to ride on the forks. He might fall off the forks, getting injured.

Do not put your hands or feet into the load handling system
Never put your hands or feet on the mast or mast connecting members; otherwise your hands or feet might be cut if the mast moves unexpectedly.

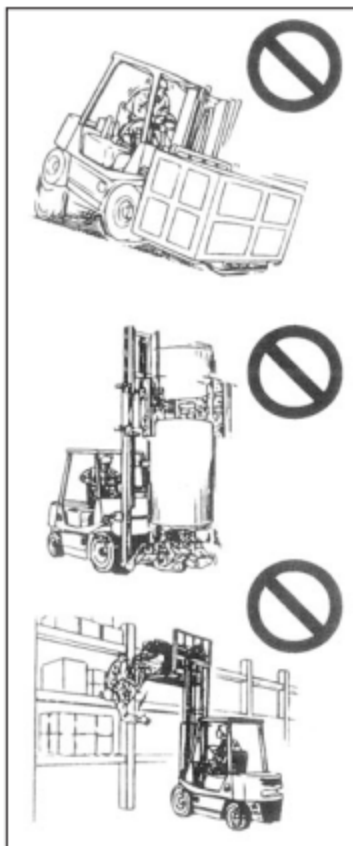

⚠ Do Not Lift Off-Centered Loads

Ensure loads are evenly positioned across the forks and aligned with the truck's center of gravity. Off-centered loads can cause tipping or loss of control.

⚠ Make Loads Contact the Load Backrest

Insert forks fully into the pallet so the load rests against the backrest. This prevents shifting or falling during movement.

⚠ Do Not Lift Unstable Loads

Avoid handling loose or unstable materials. Confirm that loads are secure and balanced before lifting.

⚠ Use Caution When Handling Loads

Secure loads with ropes, straps, or other restraints to prevent items from falling off during transport.

⚠ Do Not Stack Loads Too High

Do not stack loads higher than the top of the load backrest. Excessive height increases the risk of falling materials, which can cause injury or death.

⚠ Do Not Tilt the Mast With Loads Raised

Use only minimal forward or reverse tilt when stacking or unstacking loads. Never tilt forward unless the load is positioned over the stack—doing so can cause the forklift to tip forward.



⚠ Do Not Lift or Start With Mast Tilted Forward

When the mast is tilted forward, do not lift, start, or move the forklift. Always return the mast to a neutral position before operating.

⚠ Do Not Stack or Unstack Loads on a Slope

Perform stacking and unstacking only on level ground. Uneven surfaces can cause instability and tipping.

⚠ Keep Lift Chains Tight

Loose or slack chains can cause the carriage or mast to hang up, leading to sudden load drops or tipping. Inspect and maintain proper chain tension at all times.

⚠ Do Not Use the Forklift for Unintended Purposes

Never use the forklift to push other vehicles, open doors, or move freight car doors. Operate only within the manufacturer's intended use.

⚠ Do Not Hoist or Tow Loads Improperly

- Do not hoist loads using ropes or cables hung on the forks.

- Do not tow other vehicles.
- Do not push or pull loads with the forks—this can damage the load or cause tipping, especially at high lift heights.

⚠ Adjust Fork Spacing Properly

Set fork spacing according to the size and shape of the load. Proper spacing ensures balanced lifting and prevents shifting.

⚠ Adjust Fork Spacing With Feet, Not Hands

Use your feet to adjust fork spacing. Never use your hands—pinch points between the forks and carriage can cause serious injury.

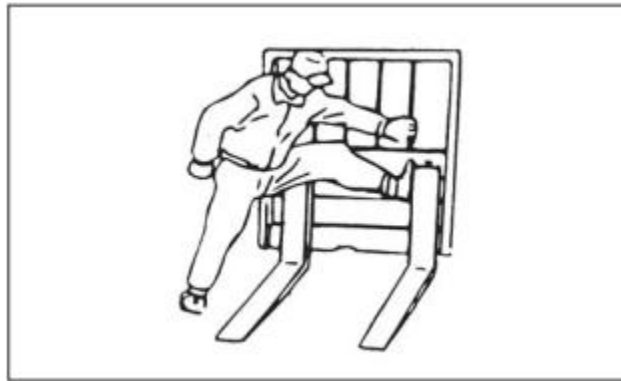

⚠ Ensure Forks Are Securely Locked

After adjusting fork spacing, lock the forks with stoppers. Unlocked forks can slide during travel, causing loads to fall.

⚠ Keep Chain Tension Even

Ensure the right and left lift chains have equal tension. Uneven tension can cause loads to tilt or shift, even if properly placed, and may lead to broken chains.

⚠ Pay Attention to Fork Tips

Fork tips are sharp and can cause injury. If they catch on obstacles, the forklift may lose control and cause an accident. Always maintain awareness of fork position and clearance.

⚠ Keep Only the Guide in the Work Area

During operation, only the designated guide should be near the forklift. Keep all other personnel and vehicles clear of the working zone.

⚠ Do Not Allow Others or Trucks to Approach During Operation

Maintain a safe perimeter around the forklift while handling loads. Unexpected movement or contact can cause serious injury.

⚠ Work With a Guide When in a Group

When multiple people are involved, assign one person to give clear guidance and follow their instructions precisely.

⚠ Use Strong Pallets and Skids

Always use pallets and skids capable of supporting the full load weight. Damaged or weak pallets can collapse, causing the load to fall.

⚠ Handle Long or Bulky Loads With Extreme Caution

Lift and lower carefully to avoid striking nearby objects. Keep the load as low as possible while moving. Turn slowly to prevent shifting or falling.

⚠ Be Alert for Overhead Hazards

Watch for overhead cables, pipes, sprinklers, or beams. Contact with overhead structures can cause the load to fall or the truck to tip. Remember that mast height increases when forks are raised.

⚠ Do Not Pick Up Loads From Another Truck

Never take loads from the raised forks of another forklift. This can create off-centered loads or cause the load to fall.

⚠ Do Not Hold Loads by Hand

Never steady or hold loads manually. If the forklift moves unexpectedly, the load can fall and trap the operator or bystander.

⚠ Do Not Squeeze Loads Into a Stack

Avoid using traction force to push loads into a stack. This can damage both the load and the forklift, and may cause tipping.

⚠ Do Not Hang Loads With Wire Ropes Attached Directly to Forks

Never attach wire ropes directly to the forks or attachments. If a rope breaks or slips, it can cause serious injury or overturn the forklift. Using a rope on only one fork is especially dangerous—it can shift the center of gravity and cause tipping.

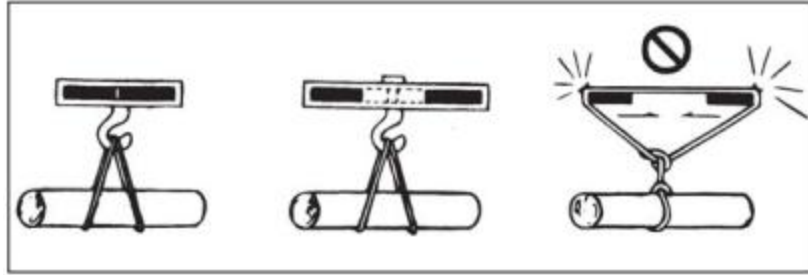

✔ Use Proper Attachments

Use a **hook attachment** or **crane arm** designed for hanging loads. Ensure wire ropes are strong enough to support the load and properly secured. Keep rope lengths short, with an adequate spread angle between legs for stability.



Parking

⚠ When Leaving the Forklift

Before leaving the truck, follow these steps:

1. Lower the forks to the ground in an out-of-traffic area.
2. Tilt the forks slightly forward so the tips rest against the ground.
3. Apply the parking brake.
4. Set the direction control lever to neutral.
5. Turn off the key switch.
6. Remove the key.

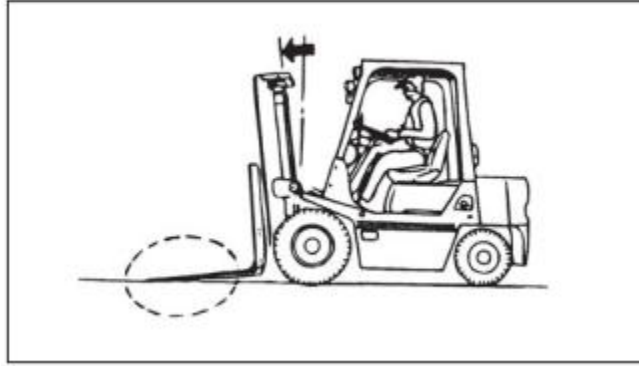

⚠️ **Park in a Safe Location**

- Park only in designated areas.
- Choose a hard, level surface.
- Avoid parking near emergency exits, stairs, fire hydrants, or flammable materials.
- Always park in an out-of-traffic zone.

⚠️ **Block Wheels When Parking on a Slope**

If parking on a slope is unavoidable, apply the parking brake firmly and block the wheels to prevent movement.

⚠️ **When Parking a Faulty Forklift**

If the forks cannot be lowered due to a malfunction:

- Attach a warning sign to the fork tips to alert pedestrians and vehicles.
- Park in an out-of-traffic area.
- Take precautions to prevent anyone from passing under raised forks.

⚠️ **Remove the Key and Post a Warning Sign**

For faulty trucks, turn off the key switch, remove the key, and attach a **DO NOT OPERATE** sign near the controls.

⚠️ **Do Not Ride on the Front Guard**

Never use the mast or truck body as a ladder or platform. Climbing on the front guard can result in entrapment between the mast and truck body, causing serious injury.



Inspection and Service

⚠ Authorized Personnel Only

Inspection and maintenance must be performed **only by qualified and authorized personnel**. Improper inspection, maintenance, or repair can cause serious accidents or equipment failure.

⚠ Before Inspection

- **Park on a hard, level surface.** Ensure the area is dry and free of dust.
- **Provide adequate ventilation.** When working indoors, maintain good airflow.
- **Keep fire prevention equipment nearby.** Know how to use it.
- **Lower forks and attachments to the ground.**
- **Turn off the key switch** and disconnect the battery receptacle.
- **Set all control levers to neutral.**
- **Ensure accelerator and load control levers are neutralized.**

⚠ Cleanliness and Fire Safety

- **Wipe off any spilled oil or grease.** Contaminants can hide cracks or defects.
- **No open flames or smoking.** Never use fire near lubricants, batteries, or oily materials.
- **Avoid loose clothing.** Wear protective gear suited to the job.

⚠ Personal Protective Equipment

Always wear:

- Hard hat
- Safety shoes
- Safety glasses

- Gloves

⚠ **Worksite Safety**

- **Use caution when working on the truck.** Avoid falls.
- **Never place feet under the forks.**
- **Watch for pinch points.** Keep fingers clear when closing battery covers or doors.

⚠ **Working Under Raised Forks or Attachments**

If it is absolutely necessary to work beneath raised forks or attachments, place a **stable support** under the inner mast and/or carriage to prevent accidental lowering. Never rely solely on hydraulic pressure to hold the forks in place.

⚠ **Team Coordination**

When working in a group, designate a leader and follow their instructions carefully to maintain safety and efficiency.

⚠ **Use Appropriate Tools**

Always use tools designed for the specific maintenance task. Improper tools can cause damage or lead to serious injury.

⚠ **Do Not Misuse Tools**

Never use tools for purposes other than their intended function. Misuse can result in equipment failure or accidents.

⚠ **Hydraulic Oil Safety**

Hydraulic oil remains **hot and pressurized** immediately after operation. Do not attempt to drain or replace filters until the system has cooled. Hot oil can spray out and cause burns.

⚠ **Release Oil Pressure Before Working**

Residual pressure may remain in the hydraulic circuit. Before servicing, release the pressure safely. To check for leaks, wear safety glasses and gloves, and use cardboard or wood—not your hands. High-pressure oil can penetrate skin and cause blindness.

⚠ **Accumulator and Piping Inspection**

Inspection of piping connected to an accumulator is hazardous. Only qualified service personnel or authorized dealers should perform this task.

⚠ **High-Pressure Oil Contact**

If hydraulic oil under pressure contacts your skin, **seek medical attention immediately**. High-pressure injection injuries require urgent treatment.

⚠ **Disconnect Power Before Working on Rotating Parts**

Before inspecting or servicing rotating components, **turn off the key switch** and **disconnect battery receptacles**. Keep hands, clothing, and tools away from moving parts. Never bring objects near rotating mechanisms.



⚠ **Do Not Use the Mast as a Ladder**

The mast or load backrest must never be used as a ladder or climbing aid. Unexpected mast movement can cause crushing or cutting injuries. Always use proper ladders or platforms for elevated work.

⚠ **Tire Inflation Safety**

When checking or adjusting tire pressure:

- Stand **in the path of rotation**, not directly beside the tire.
- Adjust the compressor's air pressure before inflating. Excess pressure can cause tire rupture or explosion.
- Only qualified personnel should inflate tires.
- Wear **safety glasses and a mask** to protect against dust and debris.

Inflating tires to high pressure requires specialized skill—never attempt without training.



⚠ **Leave Tire Disassembly and Reassembly to Specialists**

Forklift tires operate at very high pressures (approximately **700–1000 kPa**). Improper disassembly or reassembly can cause explosions, sending parts flying and causing severe injury. Always have tires, tubes, and rims serviced by qualified professionals.

⚠ **Do Not Loosen Wheel Assembly Nuts When Changing a Tire**

The wheel assembly is secured by either a **hub-nut type** or **nut-type** system:

- **Hub-nut type:** The wheel is installed directly to the hub.
- **Nut-type:** A wedge ring locks the wheel to the hub.

Always ensure the **side ring** and **lock ring** are properly installed before removing a tire. If the lock ring is not secure, the side ring, tire, or wedge ring may burst out, causing severe injury.

⚠ **Do Not Loosen Bolts or Nuts of Split Rim Assemblies**

Split rims are held together by hub nuts and rim bolts. Never loosen these bolts while the tire is pressurized—internal pressure can cause bolts or nuts to blow off violently. When replacing rims:

- Install new rim assemblies with dowel bolts facing outward.
- After replacement, test-run the truck and verify hub nuts are tightened to the specified torque.

⚠ **Using the Jack**

- Never go under the truck while it is jacked up.
- Remove all loads before lifting.
- The operator must leave the truck during jacking.
- Lift the truck slightly off the ground and support both sides of the frame.

- Block the wheels to prevent rotation.
- Only **qualified personnel** should perform lifting or slinging work.
- Attach wire ropes to designated lifting points and ensure they are strong enough to support the truck.

Handling Batteries

Battery electrolyte contains **dilute sulfuric acid**, which is highly corrosive.

- If electrolyte contacts skin or clothing, **flush immediately with plenty of water**.
- If electrolyte enters the eyes, **rinse thoroughly and seek medical attention**. Sulfuric acid can cause severe burns or blindness—handle batteries with extreme care.

Personal Protective Equipment

Always wear **rubber gloves, boots, and safety glasses** when handling, charging, or servicing batteries. Protect yourself from battery electrolyte and electrical hazards.

If Electrolyte Is Swallowed

If someone accidentally ingests electrolyte:

- Have them drink plenty of water or milk mixed with egg white and salad oil.
- Seek medical attention immediately.

Fire and Explosion Prevention

Batteries release **hydrogen gas**, which is highly explosive.

- Never smoke or use open flames near batteries.
- Avoid sparks—turn off the charger switch before connecting or disconnecting cables.

Battery Terminal Safety

- **Do not short both poles** when checking battery charge.
- **Disconnect the negative (-) terminal first** when removing the battery; reconnect it last when reinstalling.
- **Do not connect or disconnect battery receptacles** while circuits are live (electric trucks).
- **Avoid placing metal tools** on the battery case.
- Ensure terminals are tight and correctly connected.

- When tightening the positive terminal, prevent the tool from touching metal parts of the truck.

⚠ **Battery Electrolyte Level**

Maintain electrolyte between the **UPPER** and **LOWER LEVEL** marks. Low levels can damage internal components and shorten battery life. Add purified water when necessary.

⚠ **Battery Cleaning**

Before cleaning, ensure battery caps are securely tightened to prevent contamination.

⚠ **Ventilation During Charging**

Hydrogen gas is released during charging. Provide adequate ventilation and keep the battery cover open to prevent explosion risk.

⚠ **Charging Procedures**

Follow the **charger manufacturer's instructions**.

- No fire or sparks near charging batteries.
- Monitor electrolyte temperature—ensure it stays **below 35 °C**.
 - If temperature reaches **50 °C or higher**, stop charging and allow cooling before resuming.

⚠ **High-Voltage Battery Safety (Electric Trucks)**

Batteries in electric trucks exceed **48 volts** and can cause electrical shock or burns if touched. Handle with extreme caution and follow all lockout procedures.

⚡ **Static Electricity Hazards**

- Static electricity can ignite gases or cause explosions when cleaning battery surfaces or covering them with vinyl.
- Before working on the battery, discharge static from your body by touching a grounded metal object away from the battery.

⚠ **Using Booster Cables (Engine Trucks)**

When starting the engine with a booster cable:

- Wear **safety glasses**.
- Ensure the dead battery does not contact the charged vehicle.
- Shut down both engines before connecting cables.

- Prevent cables from tangling in fans or belts.
- Connect **positive (+)** to **positive (+)** and **negative (-)** to **negative (-)** only. Incorrect connections can cause sparks or explosions.

Do Not Jump-Start the Truck

Never attempt to jump-start the truck directly. Sudden movement may cause the vehicle to jerk and result in injury.

Waste Disposal

Dispose of **waste oil, solvents, and discharged batteries** according to local environmental regulations.

Handling Long-Life Coolant (LLC) – Engine Trucks

LLC is **flammable and poisonous**.

- Label containers “Dangerous Substance” and store out of reach of children.
- Never smoke or use open flames near LLC.
- If swallowed, drink plenty of water, induce vomiting, and seek medical attention immediately.

Lifting the Truck

Never attach ropes or wires to the **overhead guard** or **counterweight** for lifting. This can damage the chassis or cause the truck to fall. If lifting is required for transport, use the **optional Chassis Lifting Eye** and consult your authorized dealer.

Caution Plates

Caution plates are attached to the lift truck to explain:

- Safety precautions to observe during operation
- Procedures for proper use and maintenance

Operators must read both the caution plates and the manual descriptions. If any decals are damaged or missing, they must be replaced immediately.

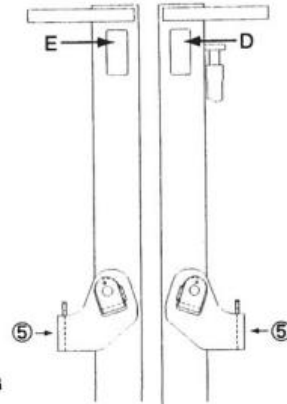
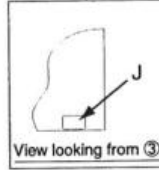
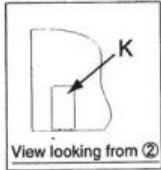
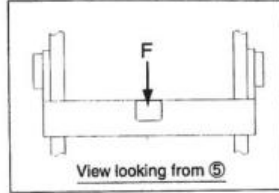
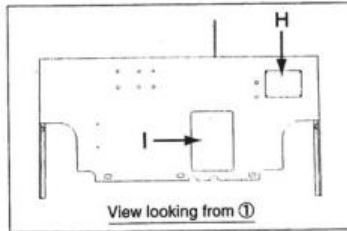

- | |
|-----------------------------------|
| B: Parking brake lever adjustment |
| I: List of lubricating locations |
| L: Battery charger handling |
| M: Battery handling |

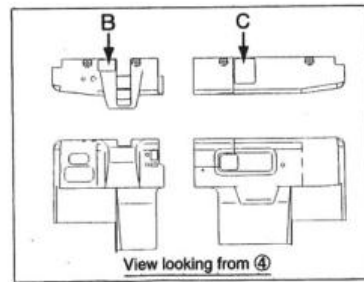
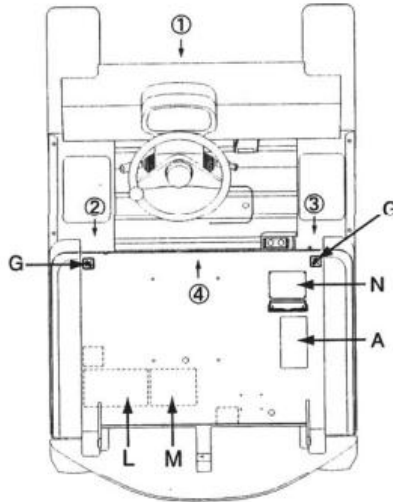

A. Safe operation

⚠ WARNING

YOU MUST FOLLOW THESE RULES TO AVOID SEVERE INJURY OR DEATH TO YOURSELF AND OTHERS.

1. Operate truck only if trained and authorized by your employer. Know Operation & Maintenance Manual and all work rules.
2. Safety check truck every day. Do not start if damaged or faulty; stop if problems start. Repair allowed only by trained, authorized mechanics.
3. Turn, start, stop, and handle loads smoothly and slowly. Carry loads low and tilted back; stack only on level using minimum tilt.
4. Look where you are going. Watch out for people, hazards on floors and overhead, drop-offs and tail swing clearance.
5. Truck overturn can kill you. Slow for turns even when empty. Never turn on inclines.
6. Do not lift overweight or loose loads. Move slowly with wide, high, or long loads. Keep forks wide and fully under loads. Travel in reverse if loads block view. Attachments require special training, ask your employer.
7. Keep loads upgrade on all inclines. Slay clear of ramp and dock edges. Make sure dockboards and trailers are secure before going on them.
8. Overhead guard and load backrest must be on truck. Always keep yourself completely inside guard.
9. Stop engine when refueling. Follow Operation & Maintenance Manual and employer's work rules about fuel, battery and tire maintenance hazards.
10. Forks can fall rapidly even with light loads. Do not raise people or allow them under forks. No passengers allowed on truck.
11. Park only in authorized areas, never on inclines. Lower forks to bottom, put direction control in neutral, turn off key and make sure parking brake is set.
12. Fasten the seat belt, when operating the lift truck.

C. Warning for front guard

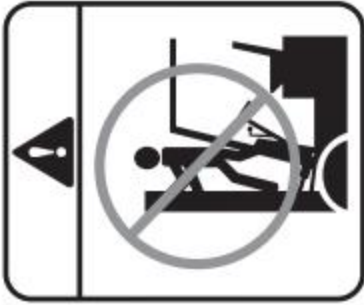

F. Warning for mast connecting members



D,E. Warning for load handling means

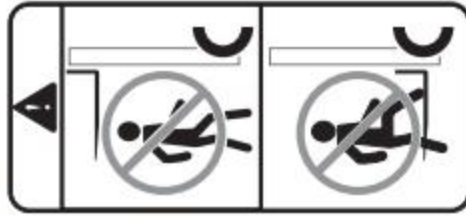

G. Entanglement



H. Name plate

HYTSU **FORK TRUCK LOAD AND WARNING NOTICE**

OPERATORS MUST BE TRAINED AND AUTHORISED. DO NOT OPERATE THE LIFT TRUCK IF IT IS IN NEED OF REPAIR. THIS CAPACITY PLATE IS NOT TRANSFERABLE AND IS INVALIDATED BY ANY CHANGE TO SPECIFICATIONS.

HYTSU GROUP

MODEL: _____

SERIAL NO.: _____

CHASSIS NO.: _____

CLOSED HEIGHT: _____

LOAD CENTRE: **500** **600** **700** mm

MAX LIFTING HEIGHT: _____ mm

Rated Capacity: _____ kg

Rating With Attachment: _____ kg

WARNING

USER OF FORK LIFT TRUCK FORKS, GRAB, SLIPPERS OR JIB

- STAY CLEAR OF OVERHEAD WIRES
- DO NOT LIFT LOAD UNLESS PLACED EVENLY ON FORKS
- DO NOT TRANSPORT OR MANEUVER WITH LOAD RAISED ABOVE 300mm EXCEPT TO CLEAR OBSTRUCTIONS AND THEN ONLY WITH MAST TILTED BACK TOWARDS DRIVER TO PICK UP OR DEPOSIT A LOAD
- DO NOT TILT MAST FORWARD EXCEPT WHEN NECESSARY
- DO NOT NEGOTIATE ANY INCLINE UNLESS MAST ENDS UP HILL
- DO NOT REVOLVE GRAB WHEN RAISED OR WHILE TRAVELLING
- GRIP ROLL ONLY IN ITS CENTRE WHEN REVOLVING
- CENTRALISE GRAB ARMS ON CARTRIDGE BEFORE LIFTING ON JIB
- DO NOT TILT MAST FORWARD WHEN LOAD SUSPENDED ON JIB
- KEEP JIB AS LOW AS POSSIBLE AT ALL TIMES BY USING MINIMAL LENGTH SLINGS OR LIFTING BEAM
- DO NOT USE JIB ATTACHMENT UNLESS THE ALLOWABLE LOAD IS MARKED ON THE JIB AT EACH HOOK POSITION

IMPORTANT NOTICE

- Replacement parts by other manufacturers need original forklift manufacturer's seal/stamp
- Ensure compliance by fitting only genuine HYTSU replacement parts available from a HYTSU genuine parts franchised distributor or dealer
- The user of incorrect parts can impair safety and performance and may invalidate forklift warranty

* AUSTRALIAN STANDARD DUTY OF CARE AS2039 Part B 15.2

* EC certificate conformity

* American standard conformity

Only Qualified and Authorised Personnel shall be permitted to maintain, repair, adjust and inspect industrial trucks.

MANUFACTURER \ DESIGNER \ DISTRIBUTOR: **HYTSU GROUP** **MADE IN CHINA**

WEBSITE: WWW.HYTSU.COM **TEL: 0086 21 58690003** **FAX: 0086 21 58692793**

WHERE FITTED USE THE SEAT BELT

K. Warning decal for handling inflated tires

WARNING

- AVOID SEVERE INJURY OR DEATH.
- The servicing requires special training.
- When inflating tires, ensure that the pressure is out. Loosen only WHEEL LUG NUTS "A".
- Do not loosen wheel assembly nuts "B" until the tire pressure is equal to more than 100 kPa (1.5 bar).
- Read the instructions for wheel service and re-assembly. Make sure all nuts and bolts are in place and tight.
- Use air and not a pump for inflating tires. Let the air out and check for proper assembly.
- Inflate all tires in a safety cage. See MANUAL for proper procedures.

Spill type

Safety cage

N. Load chart: Do not overload! (For load charts, see page 5-4.)

A	B	C
850 (8.5)	850 (8.5) KPa (kg/cm ²)	Fb15
850 (8.5)	850 (8.5) KPa (kg/cm ²)	FB18
1000 (10)	900 (9) KPa (kg/cm ²)	FB20
1000 (10)	900 (9) KPa (kg/cm ²)	FB25

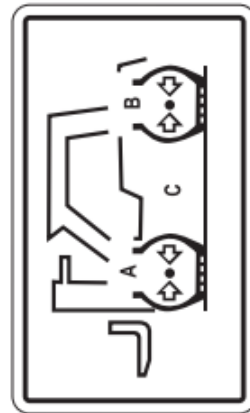

J. Tire inflation pressure (example)

CAUTION

The instructions on the caution plates carried in this manual may differ from those on the caution plates attached to the truck body. In such a case, observe the instructions on the caution plates

■ Caution plate for handling batteries

⚠ WARNING

If the battery is used or charged when the electrolyte level is below the LOWER LEVEL mark, the battery may be damaged. It may also reduce the battery life or cause an explosion. Add electrolyte so that the level is between the UPPER LEVEL and LOWER LEVEL marks.

⚠ WARNING

Hydrogen gas produced by a battery can explode. Keep all open flames and sparks away from the battery. To prevent sparks, when connecting or disconnecting the battery or charger cables, be sure to stop the engine and turn off the charger switch.



No fire



Wear safety glasses



Keep children away



Sulfuric acid



Read manual



Explosive



Electric shock

⚠ DANGER

Handle the battery carefully; otherwise you will get injured.

Pay attention to an open flame or static electricity which might cause an explosion or a fire.

Sulfuric acid will cause painful and serious burns if it gets on the skin. It can cause blindness if it gets into eyes.

Touching a conducting part with bare hands will cause an electric shock accident.

Do not connect or disconnect the battery plugs with the battery turned ON; otherwise you might get burnt or an explosion might occur.

No fire. Do not smoke. Keep sparks or flames away from batteries.

Static electricity: Do not clean batteries with a duster or dry cloth.

Ventilation: Get a good ventilation. Do not use or charge batteries in a closed place or an area where ventilation is poor.





Sulfuric acid: If sulfuric acid comes in contact with your skin or clothing, wash it away using a copious amount of water immediately. If sulfuric acid gets into your eyes, wash your eyes with a copious amount of water immediately and get to a doctor.

Electrolyte level: Keep the battery electrolyte level proper at all times. If the level is too low, the battery will build up heat; if the level is too high, electric leakage will occur.

Electric shock accident: Wear safety glasses, rubber gloves, and shoes with rubber soles when servicing or inspecting batteries.

The following symbols, found throughout this manual, alert you to potentially hazardous conditions to the owner and the operator. Become completely familiar with the truck before proceeding with operating, checking and servicing.

This manual and decal affixed to the truck use the following safety alert indications.

SIGNAL WORD	CLASSIFICATION
 DANGER	Failure to follow the instructions in the message will likely cause a serious accident or death.
 WARNING	Failure to follow the instructions in the message might cause a serious accident or death.
 CAUTION	Failure to follow the instructions in the message may cause personal injury or damage to the truck or other property.
 NOTE	The information will help to prolong the service life of the truck. The message is not directly related to accident prevention.

TRUCK COMPONENT LAYOUT

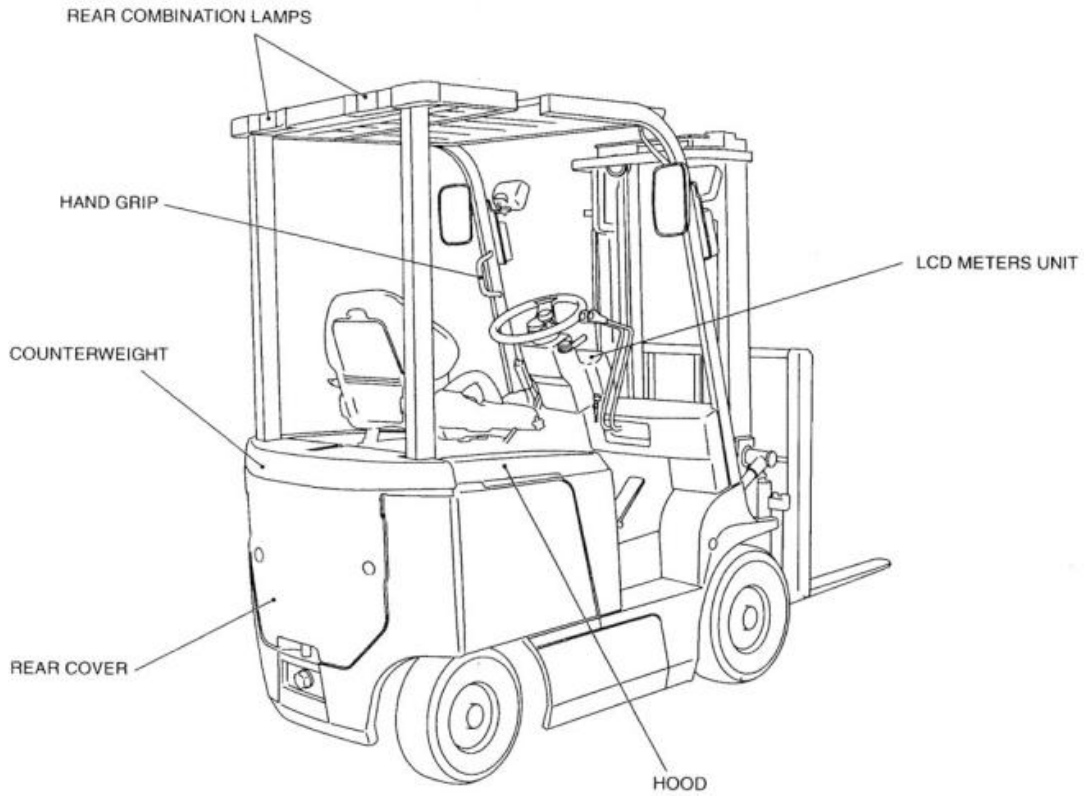
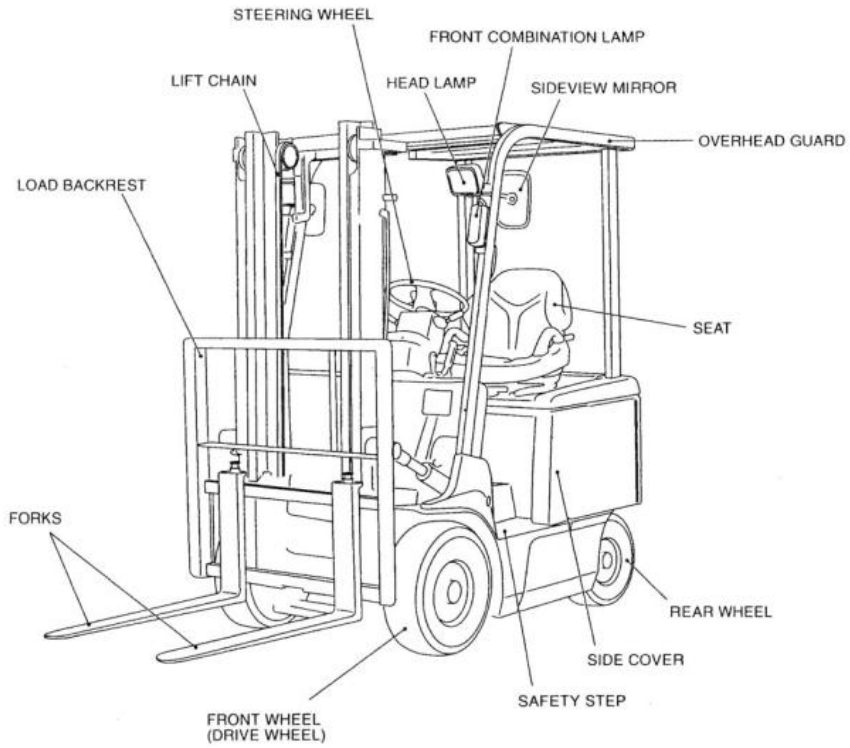

INSTRUMENTS AND CONTROLS

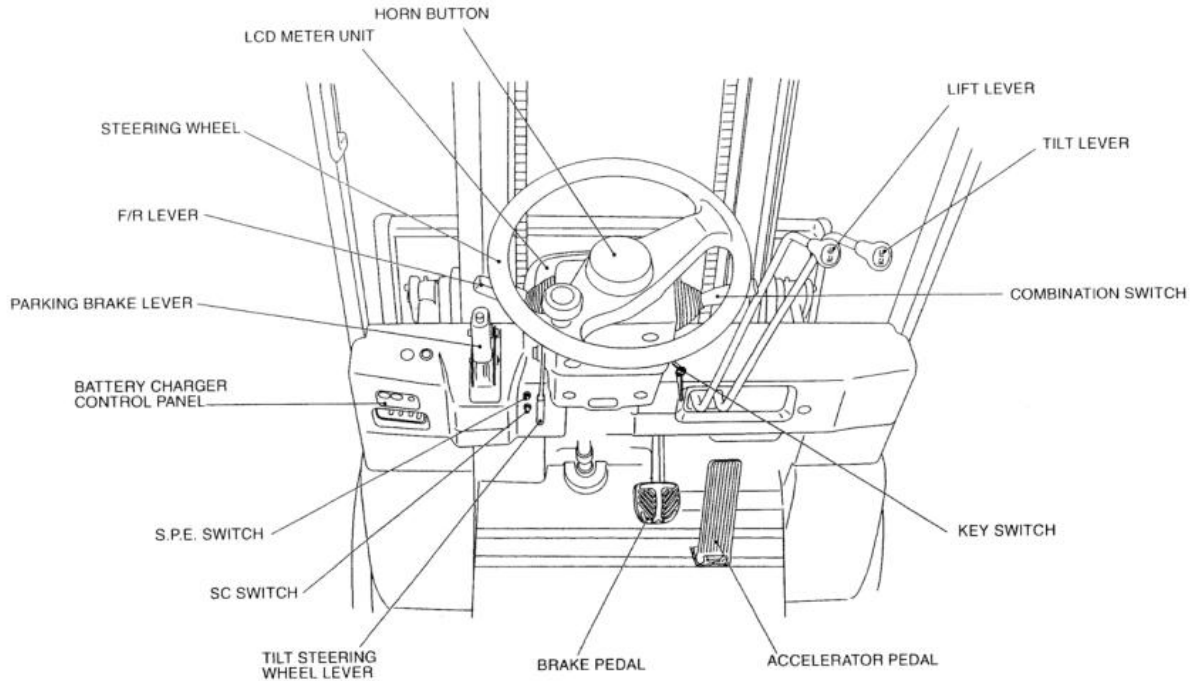

SWITCHES

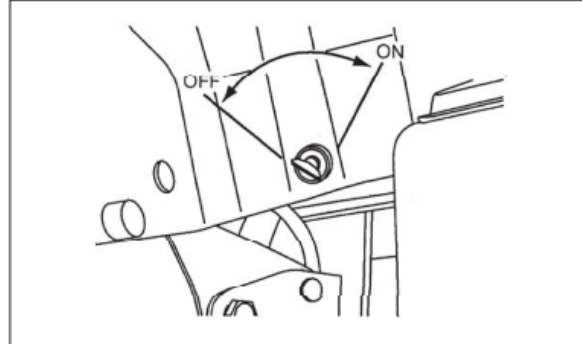

KEY SWITCH

⚠ CAUTION

Disconnect the battery receptacle before working on the electric components. The electric circuit is live even if the key switch is turned OFF.

Before leaving the truck, make sure the key switch is turned off and remove the key.

OFF.....The key switch is OFF. Key insertion and draw-out position.

ON.....The electric circuit is closed. After 1 second of self-check, the truck becomes ready for operation. The power indicator lights up.

📖 NOTE

If the following operation is carried out, the safety circuit of the truck is activated. In this state, the truck won't start. If you want to start the truck, release the safety circuit.

The F/R (Forward/Reverse) lever is operated with the key switch OFF. (That is, the key switch is turned on with the forward/reverse lever in positions other than neutral.)

– Resetting the safety circuit–
Place the F/R lever in neutral and turn the key switch OFF and then ON.

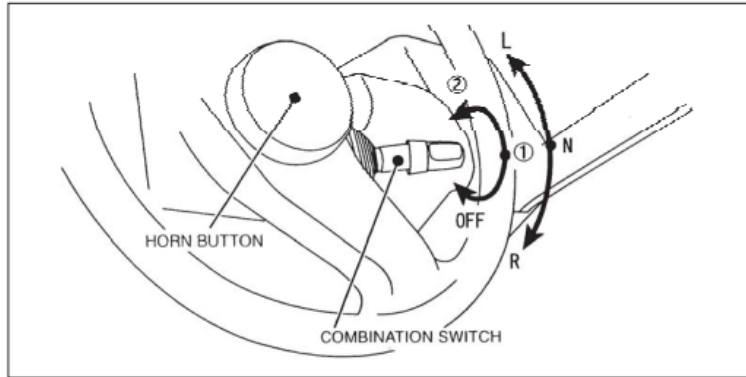

COMBINATION SWITCH (LIGHTING)

This light switch can be rotated in 2 steps.

Light \ Stage	OFF	①	②
Clearance light	OFF	ON	ON
Tail light	OFF	ON	ON
Head light	OFF	OFF	ON

NOTE
The above lights turn on or off regardless of the position of the key switch. Remember to turn them off when leaving the truck.

(TURN SIGNAL)

Use the turn signals (front and rear) to indicate the traveling direction of the truck.

L	Left lights turn on.
N	OFF
R	Right lights turn on.

NOTE
The turn signal lever automatically returns to neutral when the steering wheel is returned to the straight position.
The turn signal lever may be optionally located at the right side of the steering column.

HORN BUTTON

Press the horn button at the center of the steering wheel to sound the horn. The horn sounds regardless of the key switch position.

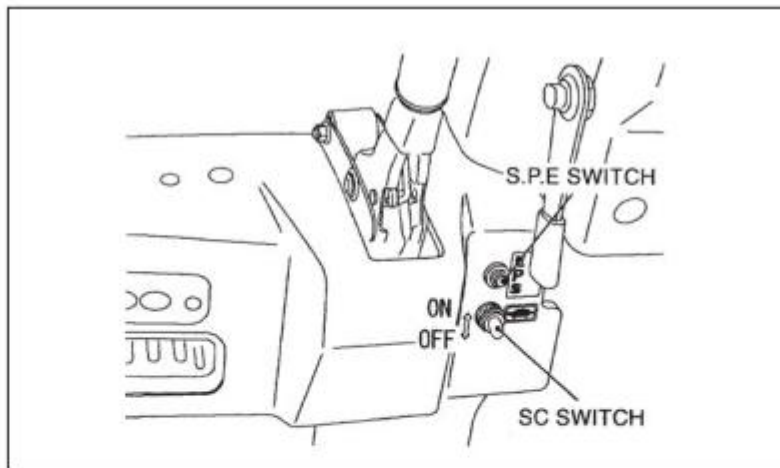

SPEED CONTROL (SC) SWITCH

When this switch is turned on, the  mark appears on the display, indicating that speed control is in action.

To release speed control turn the switch off. The  mark will disappear.

S.P.E SWITCH

Every time the S/P/E switch is pressed, the letter S, P, or E appears in turns on the LCD meter unit. Set the power mode of the truck with this switch.

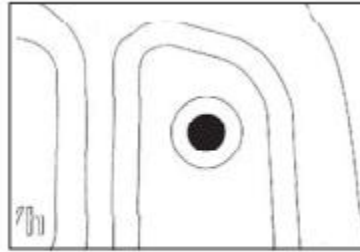

POWER LAMP

The light comes on when the key switch is turned on.

LEVERS AND PEDALS

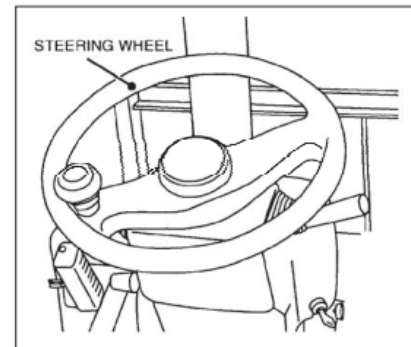
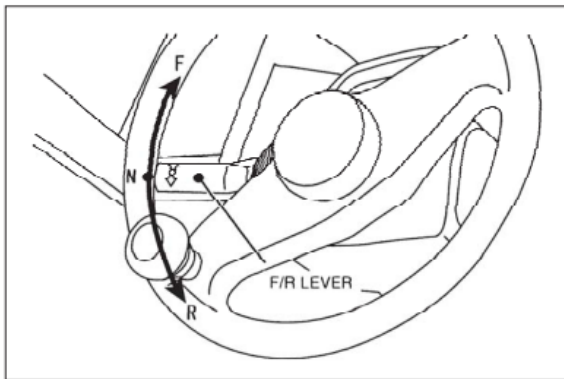

F/R LEVER

Use this lever to select the traveling direction of the truck.

F	Forward
N	Neutral (N appears on the display.)
R	Reverse (The back-up light comes on and the back-up buzzer sounds.)

■ Regeneration (switch-back regeneration)

This truck is equipped with regenerative brake system. The regenerative brake system automatically returns electric energy created by braking to the batteries for better use of energy.

It operates when the following conditions are met:

- The accelerator pedal is stepped on.
- The F/R lever is reversed while traveling.

Steering wheel

▲ CAUTION

Do not turn the key switch OFF while traveling. When the key switch is turned OFF, steering operation becomes hard.

When traveling the truck, hold the steering wheel knob with your left hand. Do not remove your hand from the knob while traveling. The truck comes with poser steering to provide smooth, light steering with the key switch on.

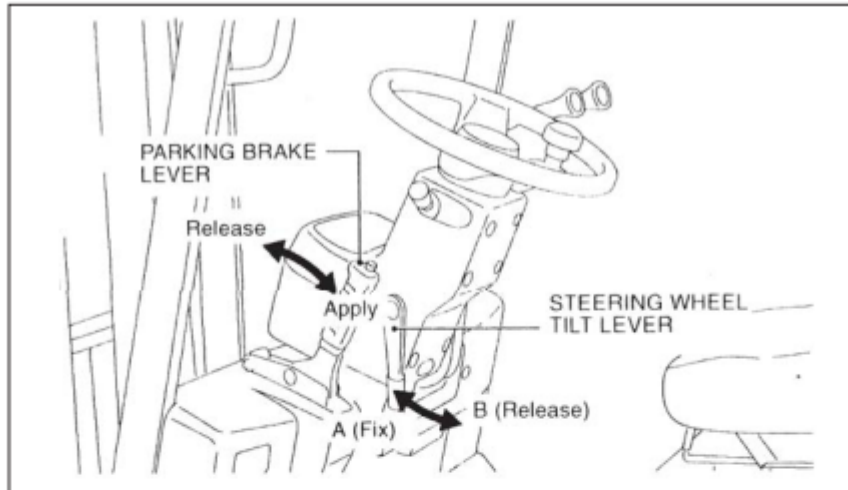

PARKING BRAKE LEVER

⚠ CAUTION

When parking on a grade, be sure to block the wheels.

Before pulling the parking brake lever, step on the brake pedal.

Use the parking brakes to park the truck. Pulling the lever toward you applies the brakes to the two front wheels. The indicator (**(P)**) lights up on the LCD. To release the parking brakes, push the parking brake lever forward.

TILT STEERING WHEEL LEVER

⚠ CAUTION

Set the steering column at the most comfortable position before trying to start the truck.

After adjusting the steering column position, turn the lever in the direction of "A" to lock the steering column.

Never try to adjust the steering

The steering wheel column can be tilted forward and backward according to the operator's physique. Turn the lever in the direction of "B" to loosen the steering wheel column. After adjustment, turn the lever to "A" to lock.

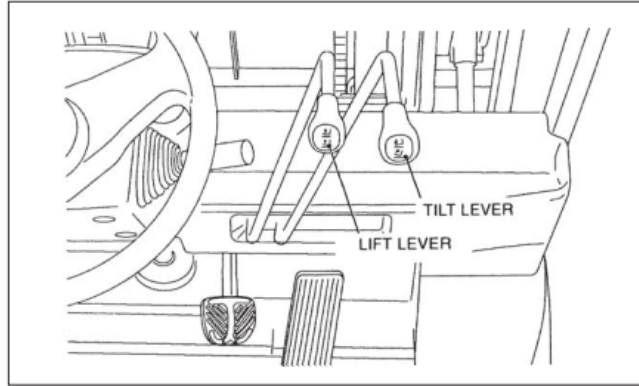

LIFT LEVER

⚠ CAUTION

Seat yourself in the operators seat and make sure there is no one around the truck before trying to operate the lift lever.

Pulling back the lever will raise the forks and pushing forward it will lower the forks. The lifting speed of the forks can be controlled by the tilt angle of the lever.

TILT LEVER

⚠ CAUTION

Seat yourself in the operators seat and make sure there is no one around the truck before trying to operate the tilt lever.

Pulling the tilt lever will tilt backward the mast and pushing forward it will tilt the mast forward.

The tilting speed of the mast can be controlled by the tilt angle of the tilt lever.

📖 NOTE

If the tilt lever is operated with the key switch OFF, the mast won't tilt forward due to the operation of the tilt-lock mechanism incorporated in the control valve. This is not the malfunction of the system.

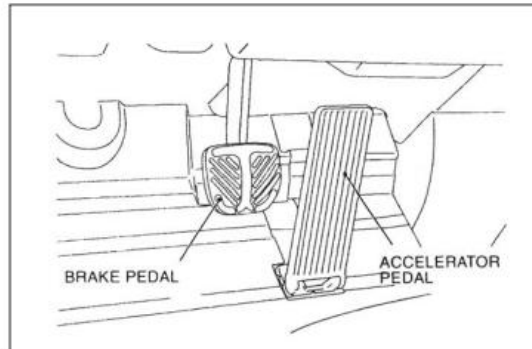

PEDALS

The truck has 2 foot controls: brake pedal and accelerator pedal (from the left).

BRAKE PEDAL

Step on the brake pedal to slow down the truck. Brake lamps light up when the brake pedal is pressed.

Before stepping on the brake pedal, release the accelerator pedal first.

ACCELERATOR PEDAL

The accelerator pedal controls the traveling speed of the truck.

Turn the key switch ON and shift the F/R lever into forward or reverse, and step on the accelerator pedal. The traveling speed is indicated on the display.

⚠ CAUTION

Brake switch

Do not remove the brake switch.

When the brake pedal is stepped on, the brake switch operates to turn the brake lamp on and activates brake regeneration.

TRUCK BODY

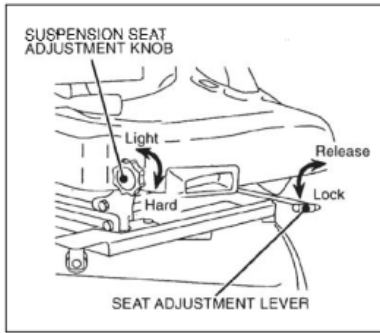

DRIVER'S SEAT SUSPENSION

⚠ CAUTION

Adjust the suspension of the driver's seat using the adjustment knob before starting the day's work or each shift. Do not try to adjust the suspension during operation.

Adjust the driver's seat suspension properly to suit the individual operator's physique and to provide best comfort. Turn the adjustment knob to the value of your weight. The seat absorbs shock and vibration to provide comfort during traveling and operation.

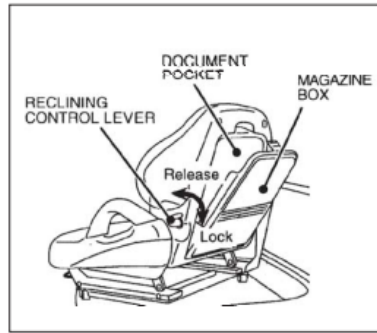

SEAT ADJUSTMENT LEVER RECLINING CONTROL LEVER

⚠ CAUTION

Adjust the seat position before starting your day's work or each shift. Make sure the seat is securely locked.

Adjust the driver's seat to a position to suit the individual operator's physique. To unlock, pull up the lever. After adjustment, try to move the seat back and forth to make sure that the seat is securely locked.

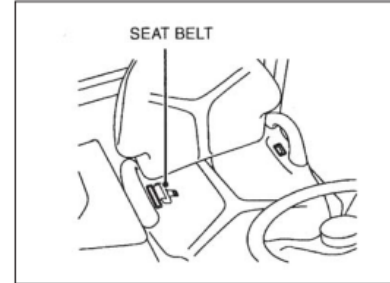

DOCUMENTS POCKET AND MAGAZINE BOX

The driver's seat has a document pocket and magazine box at its back. Use them for storing the Instruction manual and others. Remember to close the document pocket before operation.

SEAT BELT

⚠ WARNING

Be sure to fasten the seat belt before starting traveling or operator might be thrown out and, in the worst case, the operator can be crushed by the truck causing severe injury or even death.

Pull out the connector at the right side and insert it into the receptacle at the left side until it clicks. To unfasten the seat belt, press the red button by the receptacle, and the belt automatically winds up into the

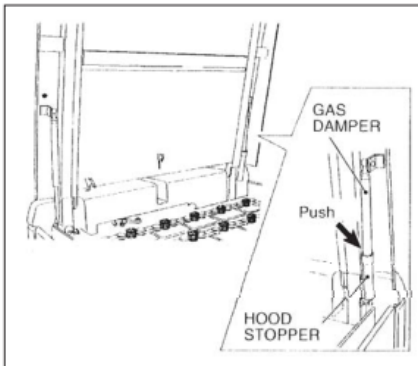

HOOD STOPPER

⚠ CAUTION

After opening the hood, make sure gas damper stopper is engaged. Use caution not to get your fingers caught in the hood when closing it.

The hood has a stopper at the middle of the gas damper. After opening the hood, make sure the gas damper stopper is securely engaged. When closing the hood, hold the hood and push the gas damper stopper to bring the hood down slowly.

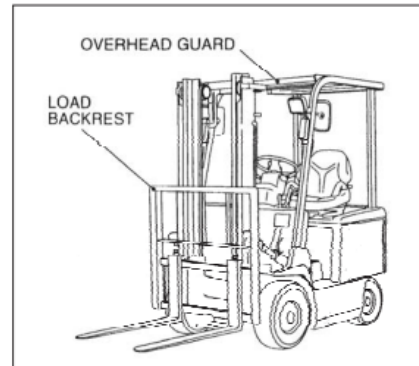

OVERHEAD GUARD

⚠ WARNING

The overhead guard is an important safety device which protects the operator from falling objects. Make sure it is securely installed. Do not use the truck with the overhead guard removed or modified; otherwise it might cause

📖 NOTE

Keep the vinyl rain gutter always clear of dust.

LOAD BACKREST

⚠ CAUTION

The load backrest is an important safety device which protects the operator from a falling load if the forks disengage from the carriage. Make sure the load backrest is securely installed. Do not use the truck with the load backrest removed or modified; otherwise it might cause

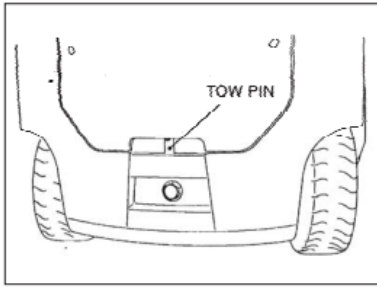

TOW PIN

⚠ CAUTION

Do not use the tow pin for towing another vehicle or for being towed by another vehicle.

Use the tow pin for the following cases:

When the truck has bogged down in the mud or a side ditch.

When loading onto or unloading from a trailer for transportation.

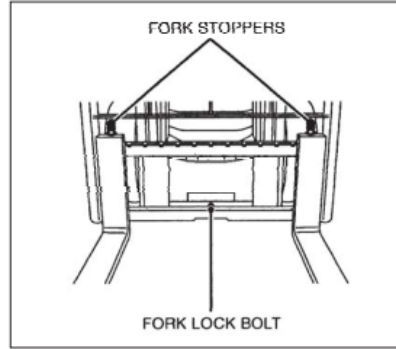

FORK STOPPER

⚠ CAUTION

The forks should be set symmetrically to the truck centerline, and fork stoppers should always be set.

When adjusting fork spacing, hold the load backrest and push the forks

Secure the forks with the fork stoppers.

Pull up the fork stoppers a little and turn 90° .

Then adjust the fork spacing using your foot according to the size of the load you

FORK LOCK BOLT

⚠ CAUTION

Do not remove the fork lock bolt other than the following cases; otherwise the forks might disengage from the carriage, causing personal injury.

When removal of the forks is needed.

When gathering the right and left forks together to the center

When a fork prong is moved to the center, it will come off the carriage. This bolt prevents the fork from being used at the

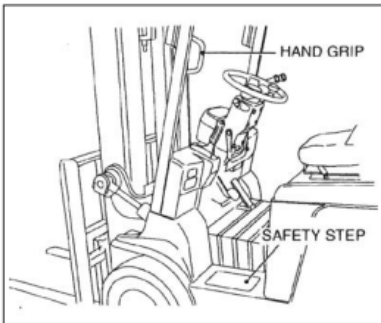

SAFETY STEP AND HAND GRIP

⚠ CAUTION

Use the safety step and hand grip when mounting and dismounting.

Do not hold the steering wheel when getting on or off. Do not mount or dismount while the truck is in motion.

The truck is equipped with a safety step at front left side of the body and a hand grip on one of the front poles of the overhead guard. When mounting or dismounting, use the safety step and hand grip.

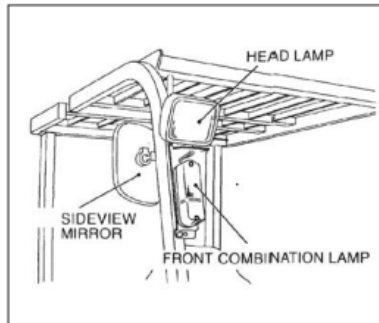

LIGHT AND LAMPS

⚠ CAUTION

Check that lights and lamps come on and off properly. If any light bulb is blown out, replace with a new one. If the lens is contaminated or damaged, clean or repair.

Front side

The truck has head lamps and front combination lamps (turn signals and clearance lamps) at its front side.

Rear side

The truck has rear combination lamps (tail lamps, brake lamps, back-up lamps, turn

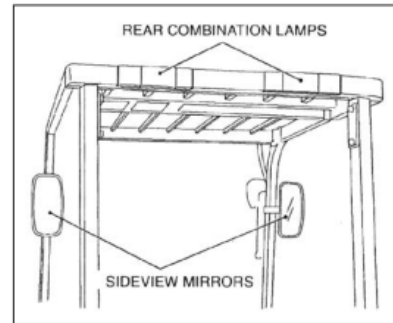

SIDEVIEW MIRRORS

⚠ CAUTION

When traveling in reverse, always look in the direction of travel. Do not rely too much on the sideview mirrors.

Keep the mirror surfaces always clean.

Adjust the sideview mirrors to gain full rear vision.

The sideview mirrors are provided on the front poles of the overhead guard, one for each.

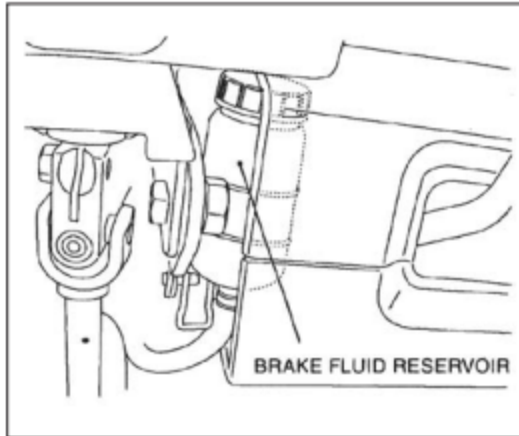

BRAKE FLUID RESERVOIR

The brake fluid reservoir is located under the front guard at the right side of the steering column. The operator can check the brake fluid level from outside.

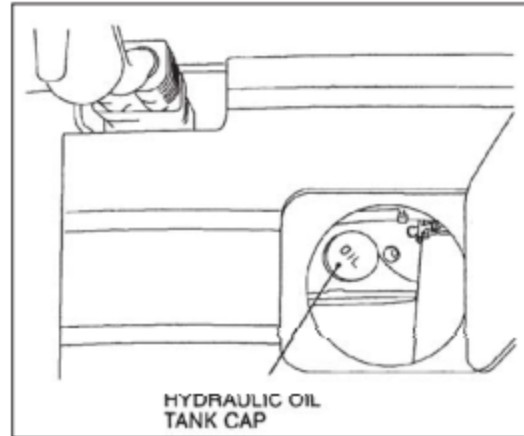

HYDRAULIC OIL TANK CAP

The hydraulic oil tank cap is located under the floor mat. The tank cap is fitted with an oil dipstick for easy level checking.

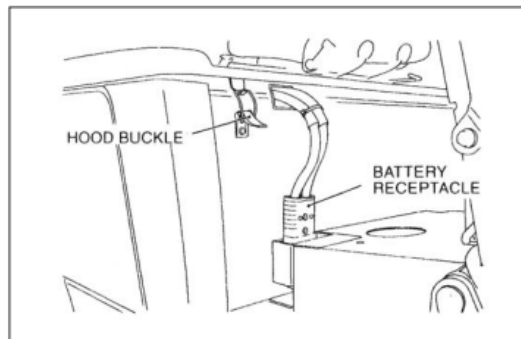

BATTERY RECEPTACLE

CAUTION

Make sure the battery receptacles are disconnected before trying to touch any of the internal electric parts.

The voltage is present in the main circuit even if the key switch is turned off.

Do not disconnect the battery receptacles while traveling. The power steering system becomes inoperative.

The battery receptacles couple and uncouple the connection between the battery and the truck's electric parts.

NOTE

When disconnecting the battery receptacles, first turn OFF the key switch.

Before trying to connect the battery receptacles, make sure the key switch is in OFF.

When giving a charge to the battery with the truck-mount charger, do not

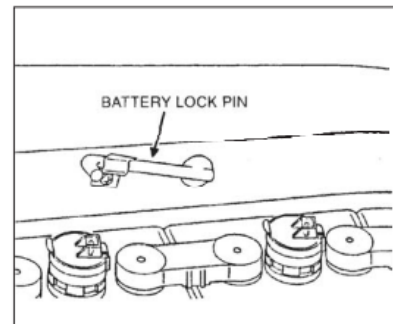

BATTERY LOCK PIN

CAUTION

Make sure to set the battery lock pin.

The battery lock pin connects the battery case to the truck body, preventing the battery case from vibrating during traveling. To replace the battery with a new one, disengage the battery lock pin and remove the battery electrolyte level sensor wiring.

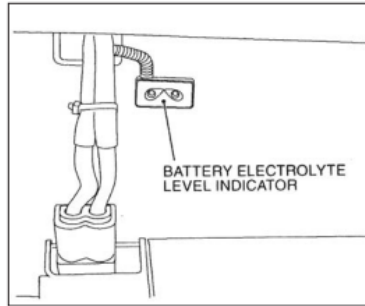

BATTERY ELECTROLYTE LEVEL INDICATOR (EXB Option)

The battery electrolyte level indicator is installed on the battery case for checking the electrolyte level in the battery. The green lamp stays on to indicate that the level indicator sensor is operating. The red lamp comes on when the electrolyte level gets close to the lower limit. If the red lamp blinks, add purified water as soon as possible. Check the electrolyte level in all cells periodically.

OPTIONAL EQUIPMENT

Here are some pieces of optional equipment which are deeply related to safe operation of the truck. For more information about optional equipment, consult your local dealer.

REAR WORK LIGHT (RWL)

CAUTION

It is advisable to use an optional rear work light when you are working in a place where sufficient light is not available.

The rear work light illuminates the road or floor behind the truck at night to allow the operator to recognize obstacles, if any, on the road or floor easily.

BEACON LIGHT (YELLOW, RED) (RLY, RLR)

Use an optional beacon light in the case when the truck is required to work near fellow workers or bystanders or when the work place is noisy.

SOUND VOLUME-ADJUSTABLE

BACK-UP BUZZER (BBA)

You can switch over the sound volumes in two stages, according to the noise level at the work place.

FORWARD TRAVEL CHIME (TAF)

When the truck travels forward, the chime sound to left fellow workers know the truck is moving.

PNEUMATIC CUSHION TIRE (UNIQUE TIRE, TR01)

Use tires of this type when you are going to work in an area where there are debris or anything that might blow the tires on the road or floor surface.

FIRE EXTINGUISHER (FE)

Use the fire extinguisher for putting out a fire. An optional fire extinguisher will be attached to one of the rear supports of the overhead guard.

PROPER OPERATION

To operate the lift truck safely and achieve optimal performance, follow the procedures below.

DURING BREAK-IN

Operate the truck under light load conditions during the first stage of operation (approximately 200 hours). This helps components seat properly and ensures long-term reliability.

- ⚠ Always warm up the truck before use, regardless of season. Allow sufficient time for hydraulic fluid and engine oil to reach operating temperature before lifting or driving.
- ⚠ Perform all specified preventive maintenance services carefully and completely. Follow the manufacturer’s maintenance schedule to prevent premature wear or failure.
- ⚠ Never “race” or play games with the truck. Avoid sudden stops, starts, or turns. Abrupt movements can cause loss of control, tip-over, or damage to the load.
- ⚠ Perform oil changes and lubrication earlier than standard intervals during break-in. Early service helps remove initial wear particles and protects moving components.

RELATIONSHIP BETWEEN LOAD AND STABILITY

The lift truck maintains balance between its own weight and the load, using the front wheels as the fulcrum when the rated capacity load is properly positioned. Always consider both load weight and center of gravity to maintain stability.



If the rated capacity is exceeded or the load is placed too far forward, the rear wheels may lift, and the truck can tip forward. This can result in severe injury or death. Loads positioned near the fork tips act as heavier loads—reduce weight accordingly.

BASIC LOAD CENTER AND RATED LOAD

⚠ CAUTION

When traveling with loads, keep the forks 15 to 20 cm (6 to 18 in.) above the ground surface and keep the mast tilted back fully.

The allowable load of a truck equipped with an attachment is reduced in comparison with that of the standard truck.

If the truck is equipped with a load-handling means such as a hinged fork, load grab, or rotating clamp, its allowable load will be reduced as compared with that of the standard truck (a truck without any attachment) for the following reasons:

Never exceed the allowable load indicated on the load chart attached onto the truck or attachment.

Reasons for a reduction in the allowable load:

- 1) The weight of an attachment is added.
- 2) The attachment shifts the basic load center position

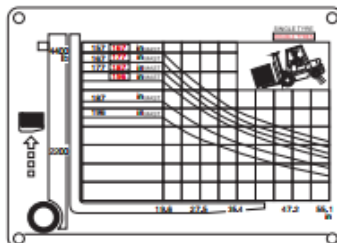

The basic load center is the distance from the front face of the forks to the load's center of gravity. The load chart shows the relationship between the load center and the allowable weight

for a 2-ton truck capacity. Always refer to the chart before lifting to ensure the load is within rated limits.

The Stability of the Lift Truck

Lift-truck stability is defined by national and international standards (JIS, ANSI B56.1, and OSHA 1910.178). Stability is maintained only when the following conditions are met:

- The ground or floor surface is level and hard.
- The truck travels under standard loaded or unloaded conditions.
- The truck is operated carefully, and the forks are not tilted forward more than necessary when stacking or unstacking.
- Load handling is performed slowly and smoothly.

Keep the truck in good working condition to ensure safe operation and travel.

In addition, keep the truck in good working condition for safe operation and traveling.

<p>Standard unloaded condition This means that the forks are raised 30 cm (12 in.) above the ground or floor surface and tilted back fully without loads.</p> <p>Standard loaded condition This means that the forks are raised 30 cm (12 in.) above the ground or floor surface with a load placed at the basic load center position of the forks.</p>

Traveling and Starting on a Slope

When traveling on a slope:

- With a load on the forks, keep the load pointed uphill.
- Without a load, keep the rear of the truck pointed uphill to prevent drive-wheel skidding.

⚠ CAUTION – Transporting the Lift Truck

When transporting the lift truck on a trailer:

- Securely lock the truck in place to prevent movement. Use **wire ropes or chains** and **block the wheels** firmly.
- When loading or unloading, or when traveling over public roads, pay attention to the truck's **overall length, height, and weight** to avoid collisions or clearance issues.

⚠ CAUTION – Loading and Unloading

- Never attempt to turn the steering wheel while halfway up a ramp—this can cause the truck to fall and lead to serious injury.
- Use **ramps of sufficient length, width, and strength** rated for the truck’s total weight.
- Before loading or unloading, **apply the trailer’s parking brake and block its wheels.**
- Ensure ramps are **securely locked** to the trailer and that surfaces are **clean, dry, and free of debris.**
- Perform loading and unloading only on a **level surface.** Both ramps must be the same height.
- When loading the truck onto a trailer, **back up slowly and carefully** to maintain control.

OPERATING THE LIFT TRUCK

⚠ CAUTION – Getting On and Off

- Do **not hold the steering wheel** when getting on or off the truck. Do **not jump**—you could slip or fall, causing injury.
- Follow these safe entry steps:
 1. Ensure no one is around the truck.
 2. Use the **safety step and hand grip** to enter from the **left side.**
 3. **Fasten the seat belt** before operation—it helps prevent injury if the truck tips over.

⚠ CAUTION – Before Starting the Lift Truck

- Wait approximately **one second** after turning the key switch **ON** to allow the control circuit to initialize before starting the truck.
- Do **not** place the **F/R lever** in *Forward (F)* or *Reverse (R)* before turning the key switch on—doing so may prevent the truck from starting.
- If the truck fails to start, return the **F/R lever** to *Neutral (N)* and retry.
- Avoid pressing the accelerator pedal abruptly.

⚠ CAUTION – **Surrounding Awareness** Before startup, ensure **no one is near the truck.** Alert nearby workers and bystanders by **honking** before moving.

Startup Preparation

1. Pull back the lift lever to raise the forks **1.9 – 3.9 in.** above the ground.

2. Pull back the tilt lever to tilt the mast fully backward.
3. Pull back the lift lever again to raise the forks **5.9 – 7.8 in.** above the ground.
4. Confirm the area is clear and **sound the horn** before starting.

⚠ CAUTION – Starting the Lift Truck

- Press the **brake pedal fully** before shifting the **F/R lever** into *Forward (F)* or *Reverse (R)*.
- When traveling in reverse, **look in the direction of travel** and stay alert for pedestrians, other trucks, or obstacles. Do **not rely solely on mirrors**—use direct observation whenever possible.

Starting Procedure

1. Step on the brake pedal.
2. Place the **F/R lever** into *Forward (F)* or *Reverse (R)*.
3. Release the parking brake.
4. Gradually press the accelerator pedal to begin moving.
5. Control traveling speed smoothly using the accelerator pedal.

NOTE Do **not** keep your foot on the brake pedal after starting the truck.

⚠ WARNING – Turning

- The higher the traveling speed or the smaller the turning radius, the greater the risk of the truck rolling over sideways. Always reduce speed before turning and maintain smooth steering control.

⚠ CAUTION – Rear-End Swing

- The rear counterweight swings outward when turning. Be alert to nearby personnel, obstacles, and structures to prevent collisions.

Unlike passenger vehicles, forklifts steer from the rear wheels, causing the rear end to swing during turns. Follow these safe turning practices:

- Slow down to approximately 3 mph (5 km/h) before turning.
- Turn the steering wheel slightly earlier than you would in a front-wheel-steering vehicle.
- Keep your left hand on the steering-wheel knob and your right hand on the load-handling levers.

- Ensure the area is clear of people or obstructions before turning.

⚠ WARNING – Simultaneous Operation of Traveling and Load Handling (Inching)

Performing travel and load-handling operations simultaneously requires skill and caution. The operator must understand:

- The load's shape, stability, and center of gravity.
- The risk of slipping, deformation, or imbalance.
- The need to lift forks horizontally at a slow speed to maintain truck stability.

Do not tilt the mast forward when the load is raised high. Only tilt forward when stacking or unstacking at low lift heights. To reduce the risk of tipping, never lift the load while turning.

Safe Inching Procedure

1. Approach the pick-up or deposit area slowly—approximately 118 – 196 in. (3 – 5 m) away.
2. Step on the brake pedal fully to bring the truck to a complete stop.
3. Gradually press the accelerator pedal to achieve a controlled travel speed.
4. Operate the lift lever to raise the forks smoothly.

SLOWING DOWN

Ease up gradually on the accelerator pedal. If necessary, apply the brake pedal to slow or stop the truck. Avoid sudden deceleration—rapidly releasing the accelerator pedal will not bring the truck to a quick stop and may cause instability. For emergency stops, press the brake pedal fully and maintain control of steering.

⚠ CAUTION – Safe Parking

- Park the truck on level, firm ground, preferably in a wide, designated area.
- If parking on a slope is unavoidable, position the load-handling attachment downhill and block the wheels to prevent rolling.
- Park in a designated or out-of-traffic area. Use cones, barriers, or signal lights if necessary.
- Avoid parking on soft ground, deep mud, or slippery surfaces.
- If the forks cannot be lowered due to a malfunction, cover the fork tips with a caution cloth and park in a safe area.
- Always check the ground condition—it may be slippery or uneven.

- Never dismount while the truck is moving. Wait until it has come to a complete stop.
- Never jump off the truck.
- When dismounting, face the truck and use the safety step and hand grip for support.
- After stopping, place the F/R lever in neutral (“N”) and ensure the truck is fully secured.

Parking Procedure

Park the truck in an out-of-traffic area and follow these steps:

1. Pull the parking-brake lever fully to apply the brake.
2. Lower the forks completely to the ground.
3. Turn the key switch OFF.
4. Remove the key and keep it in a secure location.
5. Dismount carefully using the safety step and hand grip.

⚠ CAUTION – Ground Condition

Use due caution when traveling on rough or uneven surfaces.

- When crossing railroad tracks, stop first, ensure safety, and cross at an angle to reduce impact.
- Avoid obstacles such as rocks, stumps, or potholes. If unavoidable, reduce speed and cross slowly.
- Prevent damage to the underside of the truck by crossing small bumps diagonally when space allows.
- Adjust travel speed according to surface conditions—lift-truck performance depends on ground stability and traction.

⚠ CAUTION – Traveling on Snowy or Frozen Roads

When operating on snowy, icy, or frozen surfaces:

- Avoid sudden acceleration, stops, or turns—these can cause skidding and loss of control.
- Control traveling speed carefully using the accelerator pedal.
- Increase stopping distance and operate at reduced speed to maintain traction.

HANDLING THE BATTERY

⚠ DANGER – Battery Care

Gases produced by batteries can be explosive.

- No smoking or open flames near batteries.
- Do not use fire for inspection or cleaning.
- Keep sparks, flames, and heat sources away from the battery area.

Maintain proper electrolyte levels. If the level falls below the lower limit, the battery may overheat and could explode.

Ensure adequate ventilation—never use or store batteries in confined or poorly ventilated spaces.

To prevent electric shock, wear rubber gloves and use insulated tools when servicing or inspecting batteries.

Avoid static electricity—do not clean the battery case with a dry cloth or duster.

⚠ Sulfuric acid hazard: Battery electrolyte contains sulfuric acid, which can cause severe burns or blindness if it contacts skin, eyes, or clothing.

- If electrolyte contacts skin or clothing, flush immediately with copious water.
- If electrolyte enters the eyes, rinse with water continuously and seek medical attention immediately.

⚠ WARNING – Charging Batteries

To prevent electric shock and fire hazards, follow these precautions:

- Ground the facility power source securely before charging.
- Never insert hands or tools into charging equipment while power is on or battery receptacles are connected.
- Charge batteries in well-ventilated areas, away from rain and flammable materials.
- Use acid-resistant flooring and ensure proper drainage to handle potential electrolyte spills.
- Never smoke or use open flames near charging batteries—especially near the end of charge, when hydrogen gas is released.
- Keep the hood open during charging to allow heat and gas to dissipate.
- Do not disconnect battery connectors while charging—this can cause sparks and lead to serious injury.
- Verify input voltage settings match the charger’s specifications. Incorrect voltage can cause transformer damage or short circuits.

- Keep the truck's key switch OFF during charging.
- Use fuses and circuit breakers rated for the specified capacity. Do not share the power supply with other equipment.

⚠ CAUTION – Temperature and Charging Safety

- Ensure the electrolyte temperature is below 40 °C before starting the charge. If it exceeds this limit, wait until the temperature drops.
- If the electrolyte temperature rises above 50 °C during charging, the battery's service life will be shortened.
- Avoid charging the battery when the ambient temperature is extremely low. Charging in cold storage or outdoor environments can reduce battery efficiency and lifespan.
- Frequent overcharging or equalizing charges can raise electrolyte temperature and shorten battery life. Monitor temperature regularly during extended charge cycles.

⚠ CAUTION – Charger Use and Electrical Safety

- Use a charger rated for the specific battery capacity. Using an incorrect charger or one intended for other purposes may cause electrical failure or overheating.
- Do not disconnect the charger cable from the power source while charging. If disconnection occurs accidentally, press the charge stop button before reconnecting. The truck's load-handling and travel circuits will not function until this button is pressed.
- If the LCD display does not activate after charging, press the charge stop button before restarting the truck.
- Prevent electrolyte splashes from contacting the truck body or electrical components. If contamination occurs, rinse immediately with water and contact your authorized service technician.

⚠ CAUTION – Daily Charge (Normal Charge) (EXB Option)

Charge the battery in a well-ventilated area, free from rain, moisture, and any source of flame or sparks. After each work shift—or whenever the LCD meter shows a low battery voltage alarm or the charge indicator drops to level 3 or below—begin charging immediately.

If the battery is only partially discharged, the microprocessor will automatically adjust the charge cycle. Charging time depends on battery capacity and discharge level. As a general guideline, a battery discharged 75 % – 100 % will require 8 – 13 hours for a full charge.

 **NOTE** The charge monitor may not always display the exact battery capacity. Readings may differ slightly from the LCD meter indicator—use both as reference guides.

⚠ WARNING – Electrical Safety

While charging or when cables are connected:

- Do not touch internal electrical parts.
- If inspection or maintenance is required, turn off the charger, remove the cables, and disconnect the battery receptacles before proceeding.

⚠ CAUTION – Plug Connection

Ensure all plugs are securely inserted into their respective receptacles before turning on the power supply. Loose connections can cause arcing, overheating, or equipment damage.

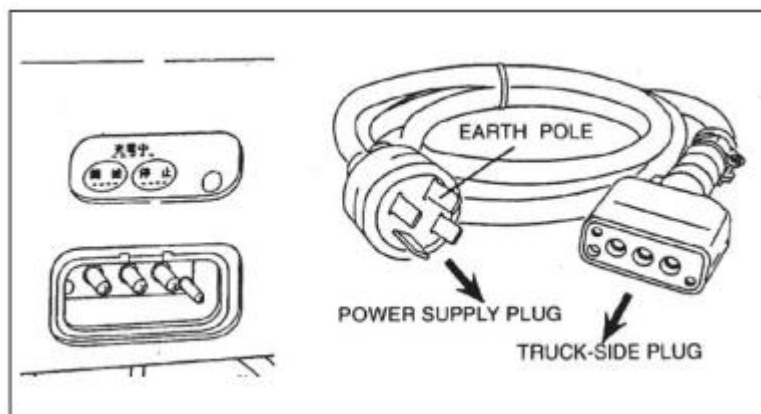

Charging Procedure

1. Turn off the truck's key switch.
2. Confirm the power-supply line switch is OFF.
3. Insert the truck-side plug of the charger cable into the truck-side receptacle.
4. Insert the power-supply plug into the power-supply receptacle.
5. Turn on the power-supply switch to begin charging.
6. Press the **“Start”** button on the charger control panel. The **“Charging in Progress”** lamp will illuminate, and charging will begin. A faint transformer hum is normal during operation. The truck-mounted charger will not start unless the **AC power supply** is on and the **battery receptacles** are properly connected.
7. When the battery is fully charged—typically **8 to 13 hours** after charging begins—the charger automatically stops, and the **“Charging in Progress”** lamp turns off.
8. After charging is complete, confirm the lamp is off. Turn the **power-supply switch OFF**, then **remove the charger plugs**.
9. Before restarting the truck, **measure the specific gravity** of each battery cell to confirm full charge.

Fluid Temperature Specific Gravity

10 °C	1.287
20 °C	1.280
30 °C	1.273
40 °C	1.266

10. Do not remove plugs while charging. If removal is necessary, follow this procedure: ① Press the Stop button. ② Turn the power-supply switch OFF. ③ Remove the plugs carefully.

NOTE: When removing a plug, grip the plug body—not the cord. Pulling on the cord may break internal wires and cause electrical failure.

Equalizing Charge (EXB Option)

The truck-mounted charger automatically performs an equalizing charge using its microprocessor. Manual equalizing charge is only required in the following cases:

- The battery has been over-discharged.
- Purified water has been added.
- The specific-gravity difference among cells exceeds 0.02 (at 20 °C).

Manual equalizing charge consists of a normal charge followed by a super equalizing charge. To perform it:

1. Complete a normal charge.
2. Press the “Super Equalizing Charge” button.
3. During operation, both the “Charging in Progress” and “Super Equalizing Charge” lamps remain lit.

Auxiliary Charge (EXB Option)

If the LCD meter shows level 3 or lower after a shift, perform an auxiliary charge during breaks. The procedure is identical to a normal charge. To stop charging, press the “Stop” button, turn the power-supply switch OFF, and disconnect the charger cables.

Super Equalizing Charge (EXB Option)

This mode combines equalizing charge and automatic auxiliary charge. An auxiliary charge automatically occurs every 24 hours after an equalizing charge, preventing low voltage even when the truck is unused for several days.

To start:

- Press the “Super Equalizing Charge” button after normal charging is complete.
- The “Super Equalizing Charge” lamp remains lit even after charging ends.
 - If the “Charging in Progress” lamp is ON, press the “Stop” button.
 - If the “Charging in Progress” lamp is OFF, press the “Super Equalizing Charge” button or turn the key switch ON.

NOTE Frequent full discharges shorten battery life. For operations requiring deep discharges, use a high-capacity battery or maintain a spare battery.

Lamp Blinking While Charging

If the “Charging in Progress” lamp blinks:

- Charging has not completed successfully.
- The charger’s second timer stops charging after 15 – 17 hours.
- A power failure lasting more than 120 hours during charging may also trigger blinking.

NOTE When the lamp blinks, no charging occurs. Identify and correct the cause before resuming. For troubleshooting, contact your authorized TEU dealer.

⚠ WARNING – Checking Electrolyte Level

If the battery is used for an extended period or charged while the electrolyte level is below the lower limit, the pole plates may deteriorate, potentially causing battery failure or explosion.

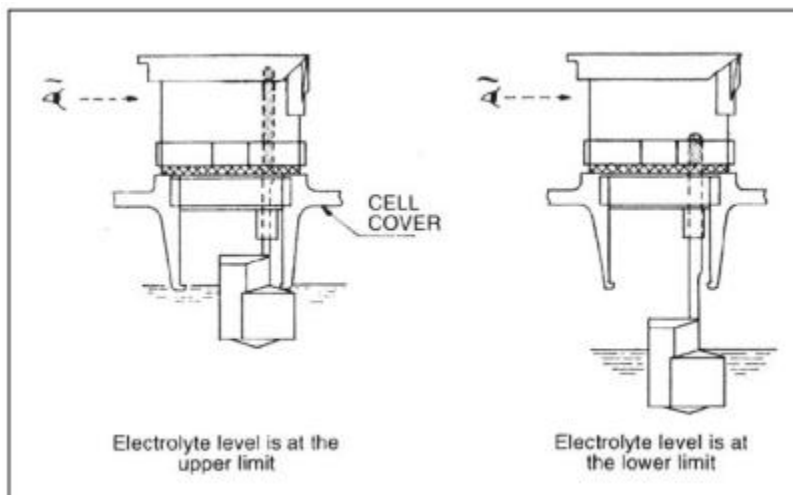

- Never use an open flame to check electrolyte levels—there is a risk of ignition or explosion.

- Always inspect the red float support rod in the cell plug to confirm the electrolyte level is at the upper limit.
- Maintain electrolyte levels between the upper and lower marks shown on the cell diagram.

⚠ CAUTION – Procedure for Adding Water

Overfilling purified water can cause electrical leakage or acid overflow. Do not exceed the specified upper limit.

Steps for Adding Water

1. Open the cap of each cell plug.
2. Pour purified water slowly through a funnel into the cell.
3. Stop adding water when the red ring reaches the top position.
4. Close the cell plug cap securely until it clicks.

Centralized Water Fill Unit (Optional)

1. Remove the centralized water-fill port cap.
2. Pour purified water using the purified-water tank.
3. Stop adding water when the red float rod reaches the top position.
4. Do not leave the tank valve open for more than 30 seconds after filling.

Conversion of Specific Gravity at Various Temperatures

The specific gravity of battery electrolyte changes with temperature. To obtain an accurate reading:

- Measure both the electrolyte temperature and the specific gravity using a hydrometer.
- Convert the measured value to the standard temperature of 20 °C using the conversion chart.

The standard specific gravity of a fully charged battery is 1.280 at 20 °C.

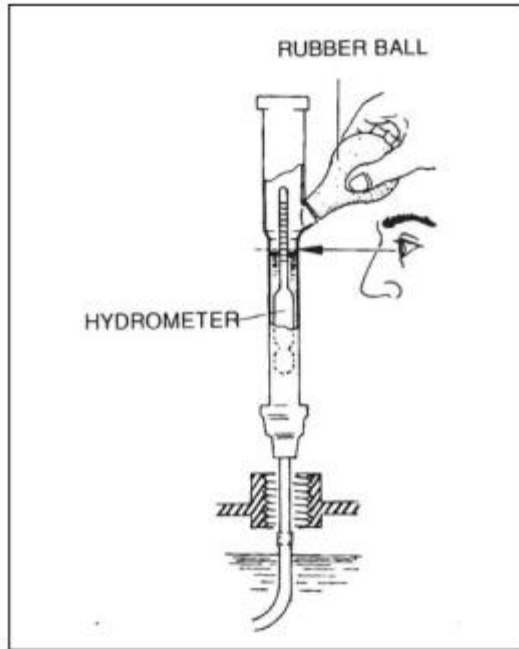

Conversion Table

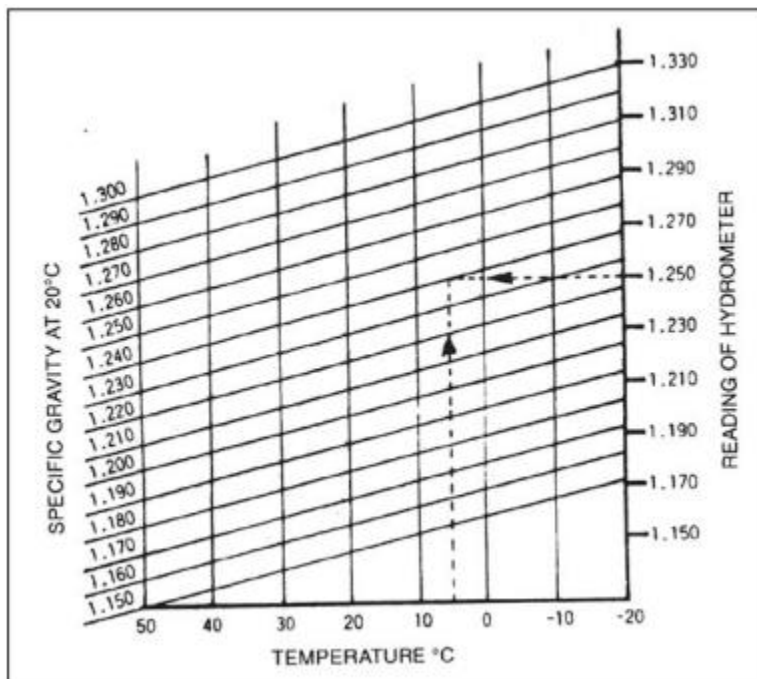

Example:

Suppose the electrolyte temperature is 5 and the hydrometer reads 1.250. When converted into the specific gravity at 20 , the figure is 1.240,0.040 lower than the standard value. Normal charge is needed.

LOAD HANDLING

⚠ CAUTION – Pick-Up

The fork spacing should be adjusted to more than $\frac{1}{2}$ and less than $\frac{3}{4}$ of the pallet width for proper load balance.

Safe Pick-Up Procedure

1. Adjust fork spacing as wide as possible while maintaining load stability.
2. Position the truck squarely in front of the load.
3. Align the pallet parallel to both forks.
4. Insert the forks fully into the pallet.
5. Lift the load:
 - Raise the forks 1.9 – 3.9 in. off the ground and check stability.
 - Once stable, tilt the mast fully backward and lift the forks 5.9 – 7.8 in. off the ground before moving.
6. When handling bulky loads that restrict visibility, drive in reverse or sideways to maintain a clear view.

⚠ CAUTION – Stacking

Never tilt the mast forward with the load raised except when the forks are directly over a rack or stack. Do not leave the truck unattended with the load upraised.

Safe Stacking Procedure

1. Approach the deposit area slowly.
2. Stop before reaching the stacking position.
3. Confirm the area is clear and stable.
4. Tilt the mast forward until the forks are horizontal.
5. Raise the forks slightly above the stacking height.
6. Move forward slowly until the load is positioned over the stack.
7. Lower the load gently into place and ensure it is securely stacked.
8. Disengage the forks using controlled lift-tilt operation, then back away.
9. After clearing the load, lower the forks to the traveling position (5.9 – 7.8 in.).
10. Tilt the mast back to neutral before resuming travel.

Unstacking Procedure

When retrieving loads from a stack, follow these steps carefully to maintain stability and prevent accidents:

1. Approach Slowly Reduce speed when nearing the area where the load will be retrieved.
2. Position the Truck Stop directly in front of the load, leaving approximately 11.8 in. (300 mm) between the fork tips and the load.
3. Inspect the Stack Check the condition of the stacked materials and ensure stability before proceeding.
4. Align the Mast and Forks Tilt the mast forward until the forks are horizontal, then raise them to the level of the pallet or skid.
5. Insert the Forks Move forward slowly until the forks are fully inserted beneath the pallet. If insertion is difficult:
 - Move forward to insert $\frac{3}{4}$ of the fork length.
 - Raise the forks 1.9 – 3.9 in., then back away 3.9 – 7.8 in. with the pallet resting on the forks.
 - Lower the pallet back onto the stack.
 - Move forward again to insert the forks completely.
6. Lift the Load Raise the forks 1.9 – 3.9 in. above the stack.
7. Back Away Safely Check behind the truck for clearance and pedestrians. Reverse slowly until the load is clear of the stack.
8. Lower for Travel Lower the load to 5.9 – 7.8 in. above the ground or floor surface. Tilt the mast fully backward and proceed to the designated area.

STORING

CAUTION – Before Storing

If the lift truck is found to be defective, unsafe, or in need of repair, report the condition to your supervisor immediately. Do not operate or store the truck until it has been restored to safe operating condition.

Pre-Storage Inspection and Cleaning

Before storing the lift truck:

- **Clean thoroughly** — wipe away grease, oil, and dirt from the body using a shop rag or mild detergent.

- **Inspect for damage** — check for dents, cracks, or tire wear; remove nails or stones lodged in treads.
- **Check for leaks** — inspect hydraulic lines and fittings for oil leakage.
- **Lubricate** — apply grease to all required points.
- **Check fasteners** — verify hub nuts and cylinder-rod joints are secure.
- **Inspect mast rollers** — ensure smooth rotation.
- **Cycle the lift system** — raise forks to the top position, then lower to the bottom limit to prime oil in lift cylinders.

Daily Storage

When parking the truck for daily storage:

1. Park in a designated area and block the wheels.
2. Place the F/R lever in neutral (“N”).
3. Pull the brake lever fully.
4. Remove the starter key and store it in a safe location.

Long-Term Storage

Perform the following checks in addition to “Before Storing” and “Daily Storage” procedures:

- Park the truck on high, firm ground—avoid low or soft surfaces, especially during rainy seasons.
- Remove the battery from the truck.
 - Store it in a cool, dry place.
 - Charge once per month to maintain capacity.
- Apply anti-rust compound to exposed metal parts such as cylinder rods and shafts.
- Cover components sensitive to humidity, including the air breather and air cleaner.
- Once a week, start the truck, warm it up, and move it slightly forward and backward to circulate fluids.
- Avoid parking on soft asphalt or other surfaces that may deform under weight, particularly in hot weather.

Operating After Long-Term Storage

Before returning the truck to service:

1. Remove protective covers used during storage.
2. Clean off anti-rust coatings from exposed parts.
3. Drain any water or foreign matter from the hydraulic oil tank.
4. Charge the battery fully, reinstall it, and reconnect cables securely.
5. Perform a complete pre-operation inspection before use.

Prohibition of Washing Truck Body and Battery with Water

The truck body and battery must not be washed with water using a hose, pressure washer, or steam cleaner. Water intrusion can damage electrical components, cause corrosion, and shorten battery life. Tires may be washed with water, but the floorboard must be removed beforehand to prevent moisture from reaching the accelerator unit and the motors located beneath it. If water enters the battery, it may cause short circuits or electrolyte leakage. The battery case should be cleaned only with a damp cloth and then dried thoroughly with compressed air. If deeper cleaning is required, the battery must be removed from the truck and allowed to dry completely before reinstallation. Electrical components—including the controller, contactors, motors, transformer, charger panel, battery receptacles, meter panel box, and accelerator unit—must never be exposed to water.

Cleaning

Before cleaning, the operator must secure the truck by fully applying the parking brake, turning the key switch off, and disconnecting the battery receptacles. Dust and debris should be removed using compressed air. The frame, mast, forks, tires, rear axle, counterweight, and inner surfaces of the side cover may be washed with water as long as electrical components remain dry. The floorboard and floor mat must not be washed with water because motors are located underneath; instead, they should be cleaned with compressed air and dried thoroughly before reinstallation. The battery hood, battery case, meter panel box, steering wheel, and motors should be cleaned only with a damp cloth or compressed air.

After Cleaning

After cleaning, all moisture must be blown off and the truck inspected to ensure every component is completely dry. Any water that has accumulated around electrical parts must be removed immediately. Once the truck is fully dry, a short trial run should be performed to confirm proper operation before returning it to service. Following these procedures helps prevent electrical failure, corrosion, and battery damage, ensuring safe and reliable operation.

Item	Washing with water	Remarks
Frame surfaces, mast, forks, tires and rear axle	Allowed	Use caution not to splash water on unwashable components.
Counterweight	Allowed	Use caution not to splash water on the cover joints of the battery inside the rear cover.
Inner surfaces of side cover	Allowed	Use caution not to wet the components inside covers.
Floorboard and floorboard mat	Not allowed	Do not wash with water because the motors are located under the floorboard. Clean them by blowing air. If severely contaminated, remove them and clean with water. Make sure they are completely dry before reinstalling.
Battery hood and battery case	Not allowed	Clean them by blowing air or wiping with wet shop rag.
Meter panel box and steering wheel	Not allowed	Ditto
Motors	Not allowed	Ditto

PREOPERATIONAL CHECKS

General Condition

Before operating the truck, inspect its overall condition carefully. Examine the body for dents, cracks, or other visible damage that could affect structural integrity. Check the tires for wear, cuts, or embedded nails that may cause air loss or uneven traction. A thorough visual inspection helps identify potential hazards before operation and ensures the truck remains in safe working order.

State of the Truck

Observe the truck's inclination when parked on level ground. If the truck appears tilted to either side, this may indicate uneven tire pressure, wheel damage, or suspension issues. A tilted stance can compromise stability during lifting and travel. If any irregularity is found, do not operate the truck—contact your local dealer or maintenance department for inspection and repair.

Oil and Water Leaks

Inspect the area beneath the truck for signs of oil or water leakage. Pools or drips on the floor can indicate hydraulic, transmission, or cooling system problems. Leaks not only reduce performance but also pose slip hazards and environmental concerns. If any leakage is detected, report it immediately and have the truck serviced before use.

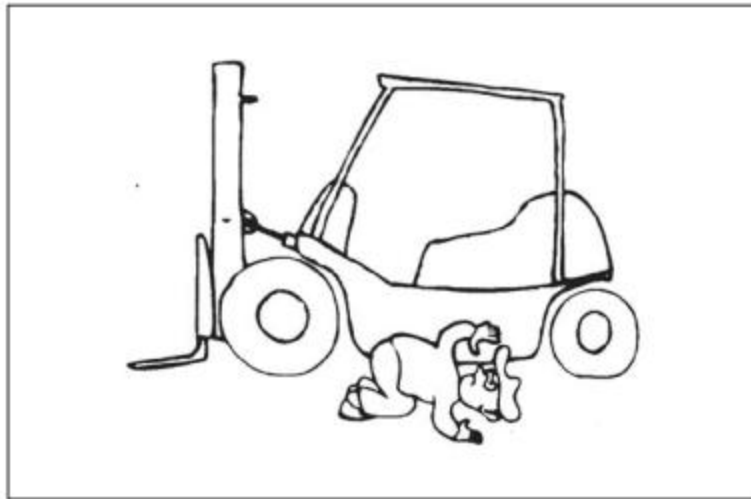
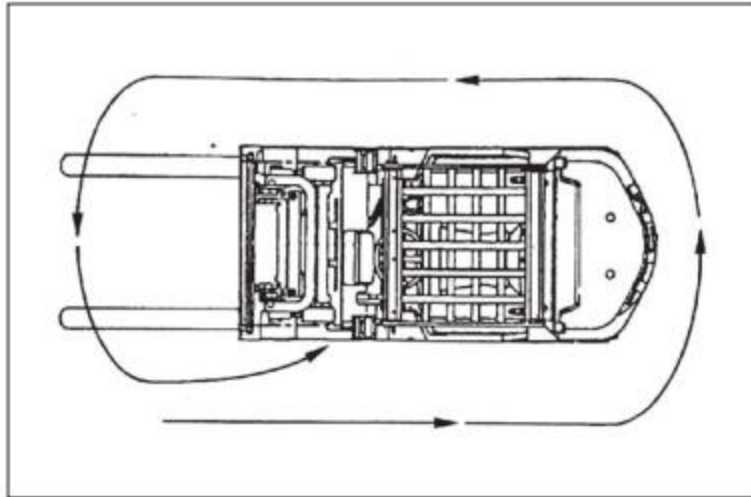

1. Defects Found in Previous Checking

Before operating the truck, confirm that any defects identified during the previous inspection have been properly repaired. Never attempt to operate a faulty truck under any circumstances. Doing so may lead to mechanical failure or serious injury. Always ensure that maintenance records are up to date and that all repairs have been verified by authorized personnel before beginning operation.

2. Tire Condition Check

Tires on lift trucks are designed to operate at high inflation pressures. Before use, inspect each tire and rim for visible damage, cracks, or deformation. Set the inflation pressure to the manufacturer's standard level, as indicated on the decal located on the left side of the front guard. Never overinflate tires. When using an air compressor, adjust the compressor pressure beforehand to prevent accidental overinflation, which can cause a tire or rim to rupture. Even

minor rim bends or tire damage can lead to sudden air loss and serious accidents. Keep tire pressure at the proper level at all times.



Low air pressure shortens tire life and can cause uneven steering or wandering during travel. The correct inflation pressure ensures stability and load-bearing performance. The standard pressures are listed below:

Front Wheel (Single) Front Wheel (Double) Rear Wheel

850 kPa (8.5 kg/cm²) 700 kPa (7.0 kg/cm²) 850 kPa (8.5 kg/cm²)

1000 kPa (10.0 kg/cm²) 850 kPa (8.5 kg/cm²) 900 kPa (9.0 kg/cm²)

To check tire pressure, remove the valve cap by turning it counterclockwise, then measure the pressure using a tire gauge. Adjust as necessary to reach the standard level. Ensure there is no air leakage from the valve before replacing the cap. Inspect the tread and sidewalls for cuts, bulges, or embedded debris, and verify that the rim is not bent. Lift trucks require high tire pressure to safely support heavy loads, so maintaining proper inflation is essential for both performance and safety.

HUB NUT CHECK

General Safety

A loose hub nut is extremely dangerous. If a hub nut loosens, the wheel may detach from the truck, causing a tip-over or serious accident. Always check that all hub nuts are properly tightened to the specified torque before operation. If any nut is found loose, retighten it immediately using a calibrated torque wrench.

Hub Nut Tightening Torque

Each model has specific torque requirements for both front and rear wheels. For models **FB15 and FB18**, the front wheel (single tire size 6.00-9-10PR) requires a tightening torque of **223 – 267 N·m (22.7 – 27.2 kg·m)**. The rear wheel (tire size 16×6-8-10PR) requires **127 – 190 N·m (13 – 19.4 kg·m)**. For models **FB20 and FB25**, the front wheel (single tire size 21×9-16PR) also requires **223 – 267 N·m (22.7 – 27.2 kg·m)**, and the rear wheel (tire size 18×7-8-

14PR) requires **127 – 190 N·m (13 – 19.4 kg·m)**. For double wheels, both the inner and outer nuts must be tightened to the same torque range of **223 – 267 N·m (22.7 – 27.2 kg·m)**.

Order of Tightening Double Nuts

When tightening double nuts, secure the inside tire's rim first using the **inner nuts (square-headed)**. Tighten these diagonally to the specified torque to ensure even pressure distribution. Next, secure the outside tire's rim using the **outer nuts (hex-headed)** and tighten them diagonally to the same torque. This sequence prevents uneven stress on the wheel assembly and ensures proper seating of both rims.

Two-Piece Rim Connecting Bolts

Rear tires on some models use **two-piece rims** composed of inner and outer sections connected by bolts. These bolts must be checked regularly for tightness. Loose connecting bolts can cause rim separation, leading to catastrophic failure. If any bolt is found loose, contact a qualified technician immediately. Tightening or loosening these bolts requires a **special tool** and should only be performed by trained personnel. Disassembly or reassembly of two-piece rims, as well as tire inflation, involves high internal pressure and must be done by a specialist using proper safety equipment. Never attempt these procedures without professional assistance.

Inspection and Maintenance

During routine checks, inspect the rims for cracks, deformation, or corrosion. Verify that all bolts and nuts are secure and that the air valve is properly seated. If any damage or irregularity is found, remove the truck from service and contact your local dealer. Maintaining correct torque and rim integrity prevents wheel separation, tire failure, and serious accidents.

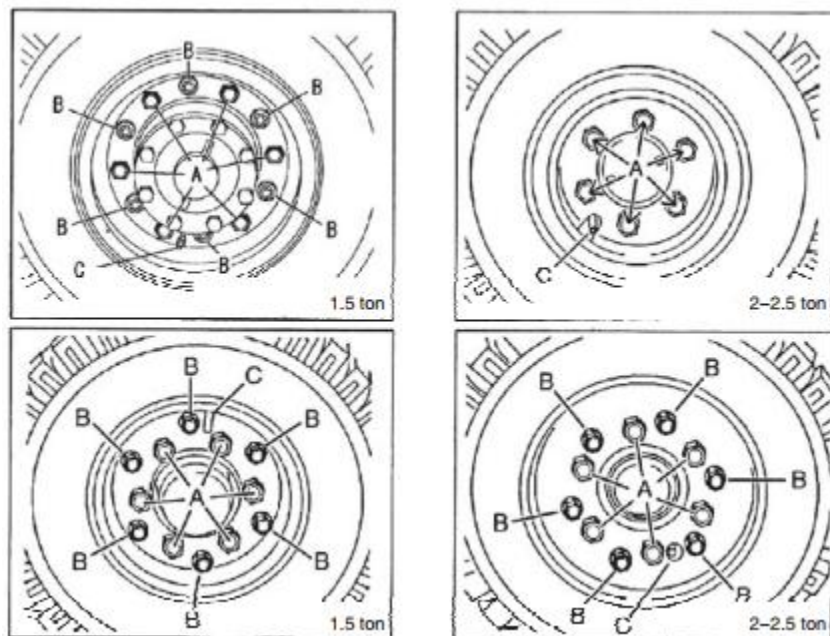

3. Overhead Guard

Inspect the overhead guard carefully before operation. Check for loose bolts, nuts, or any visible damage that could compromise structural integrity. The overhead guard protects the operator from falling objects, so it must remain securely fastened and free of cracks or deformation. If any defect is found, report it immediately and do not operate the truck until repairs are completed.

4. Brake Fluid

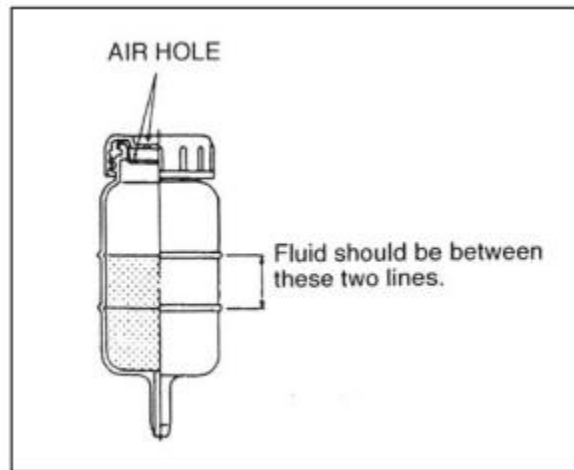

The brake fluid level can be checked externally without removing the cap of the reserve tank. Ensure that the fluid level is between the two marked lines on the tank. If the level is below the lower line, add brake fluid until it reaches the specified range. Never overfill the tank, as excess fluid may cause leakage or reduced braking efficiency. Always use the manufacturer-recommended brake fluid type. Maintaining proper fluid levels ensures consistent braking performance and prevents air from entering the hydraulic system.

5. Rear Combination Lamps

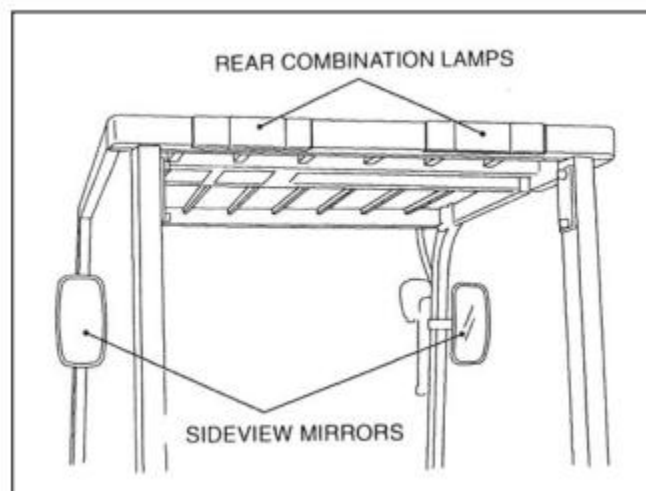

Inspect the rear combination lamps—including the tail lamp, brake lamp, backup light, and rear reflector—to ensure they are clean, intact, and functioning properly. Check that the lenses are not cracked, broken, or obscured by dirt. Clean the lamp surfaces regularly to maintain visibility and safety during operation. Proper lighting is essential for signaling and preventing accidents, especially in low-light or congested work areas.

6. Hydraulic Oil Level

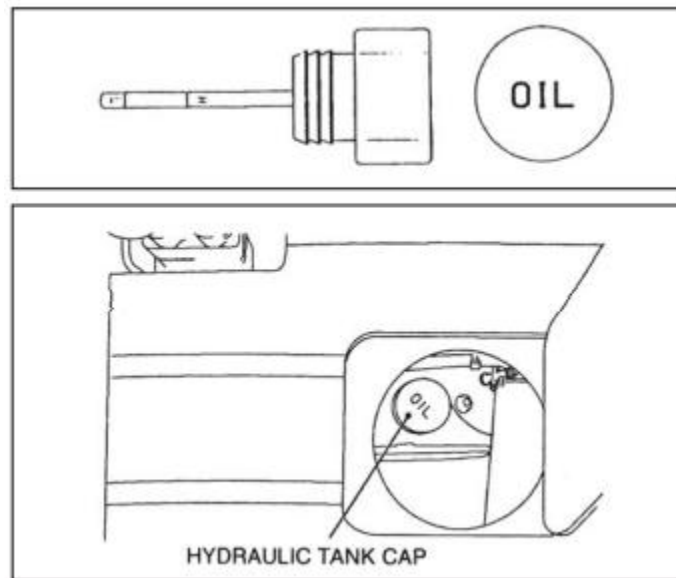

Check the hydraulic oil level using the level gauge located beneath the floor mat. To inspect, open the check cover, remove the tank cap, and wipe the gauge clean with a lint-free cloth. Insert the gauge gently, then remove it to read the oil level. The oil should reach the upper line on the gauge; if it is below the lower line, add hydraulic oil until it reaches the specified level. **Note:** Excess oil can cause leakage. If the level exceeds the upper line, drain the surplus until it returns to the proper range. Always perform this check with the truck parked on a level surface, the mast vertical, and the forks resting on the ground. Maintaining correct hydraulic oil levels ensures smooth lift and tilt operation and prevents damage to seals and cylinders.

7. Hydraulic Oil Piping and Cylinders

Inspect all hydraulic piping and cylinders—including lift and tilt systems—for signs of oil leakage. Examine joints, hoses, and fittings for cracks, wear, or loose connections. Any leakage must be corrected immediately to prevent pressure loss and contamination. Proper inspection of hydraulic components ensures safe lifting performance and prevents environmental hazards caused by oil spills.

8. Load Backrest

⚠ CAUTION

Do not modify or remove the load backrest.
The operator may get injured by a falling load.
The forks may come off the carriage.

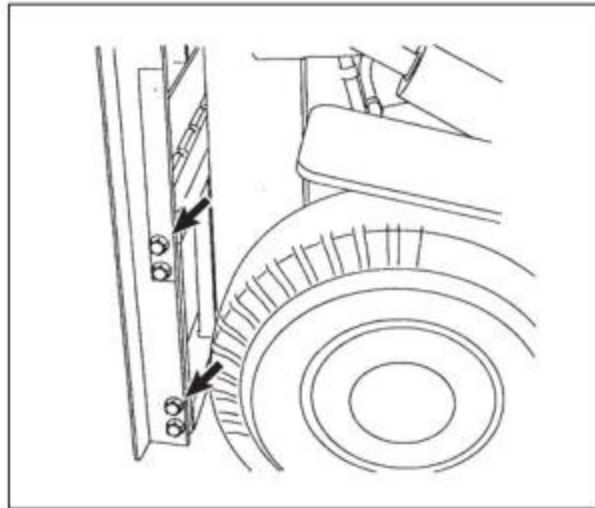

Check that the backrest is free of cracks, bends, or other damage, and verify that all mounting bolts—four on each side—are tight and secure. If any bolts are missing or loose, repair or replace them before operating the truck.

9. Forks, Fork Stoppers, and Fork Lock Bolt

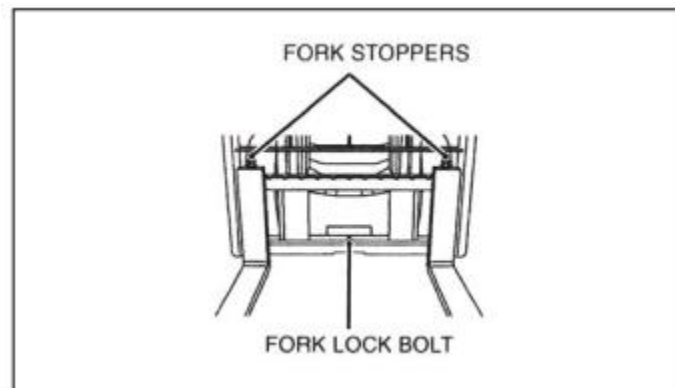

Inspect the forks and related components carefully before operation. Ensure that the fork stoppers are properly engaged and that the forks themselves are not bent, cracked, or otherwise damaged. Check the fork lock bolt to confirm it is secure and not loose. These parts are critical for safe load handling—any looseness or damage can cause the forks to detach or fail under load, leading to serious accidents. If any defect is found, report it immediately and do not operate the truck until repairs are completed.

10. Head Lamp and Front Combination Lamp

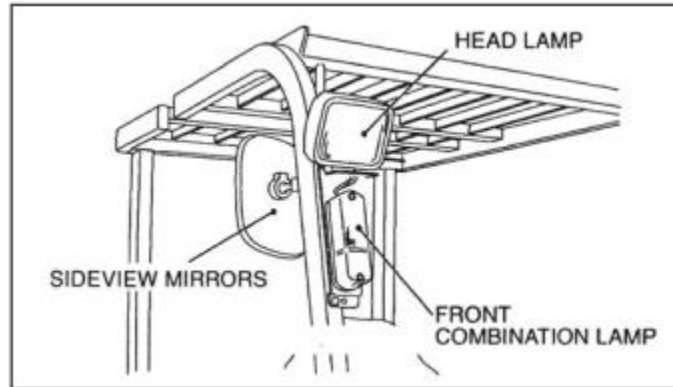

Check that the lens of the head lamp is clean, intact, and free of cracks or dirt. Proper illumination is essential for visibility and safety, especially in low-light areas. Inspect the front combination lamp in the same manner, ensuring that all lights function correctly and that the sideview mirrors are properly positioned. Clean or replace damaged lenses as needed to maintain clear visibility and compliance with workplace lighting standards.

11. Battery Electrolyte Level

⚠ CAUTION: Never operate or charge the battery when the electrolyte level is below the lower mark. Doing so will cause the battery plates to deteriorate rapidly and may lead to overheating or explosion. Never use an open flame or spark source to check the electrolyte level—hydrogen gas emitted from the battery can ignite or explode.

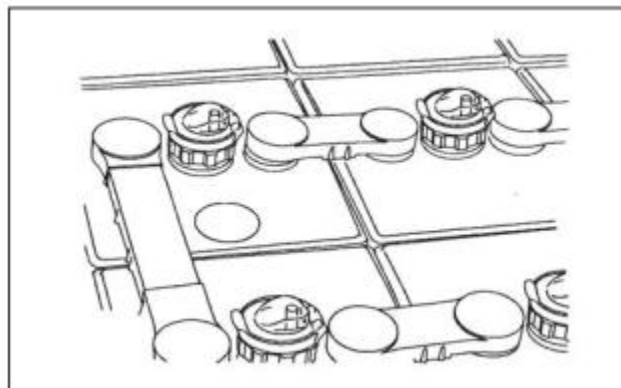

To inspect the battery, look into each cell plug and confirm that the electrolyte level mark is visible. If the level is below the lower line, add purified water until it reaches the specified range. Always perform this check before charging or operating the truck. Maintaining proper electrolyte levels ensures battery longevity and prevents electrical hazards.

12. Battery Stopper

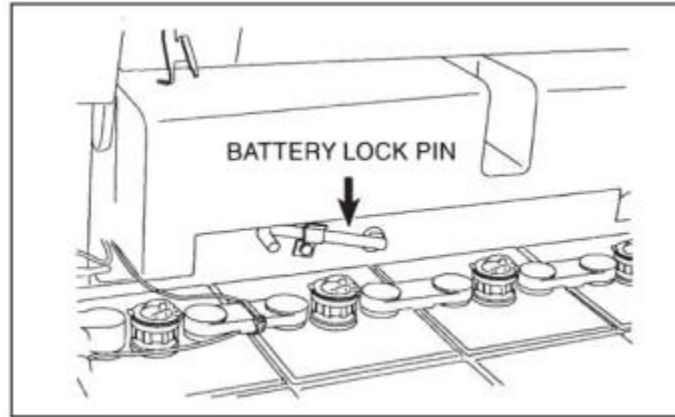

Ensure the battery stopper is secure and not loose. When closing the hood, use caution to avoid pinching fingers between the hood and truck body.

13. Driver's Seat and Steering Column

Adjust the seat and steering column for comfort and full control. Lock both securely before operation.

14. Sideview Mirror

Confirm mirrors are clean, undamaged, and properly adjusted for full rear visibility.

15. Parking Brake

Check that the brake lever holds firmly when pulled. If it fails to hold, report for service before use.

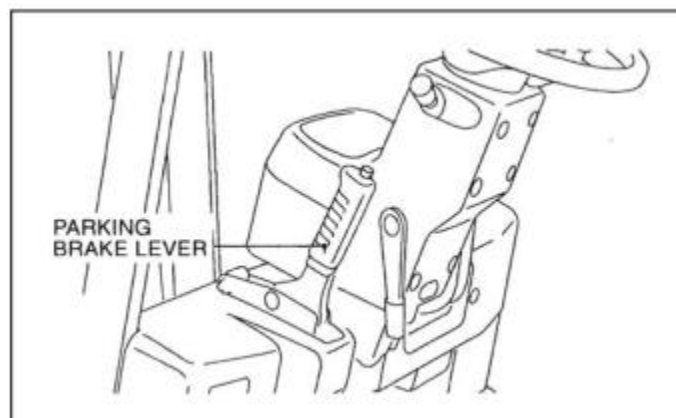

16. Load Handling Levers

Verify that lift, tilt, and attachment levers move smoothly and are not loose. Faulty levers must be repaired before operation.

17. Brake Pedals

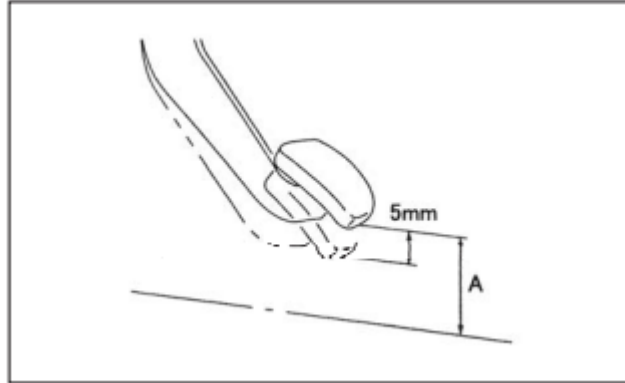

Press the brake pedal to ensure smooth movement. Release it and confirm it returns fully. Pedal play should be about 0.19 in, and the pedal height from the floor should be 3.5 in.

18. Mast Operation

Operate the lift and tilt levers two or three times to confirm smooth, quiet movement. Check that the mast and forks are not loose. If equipped with hydraulic attachments, inspect their operation as well. *Note:* Warm up the cylinders before work to lubricate seals and ensure proper function.

19. Lift Chain Tension

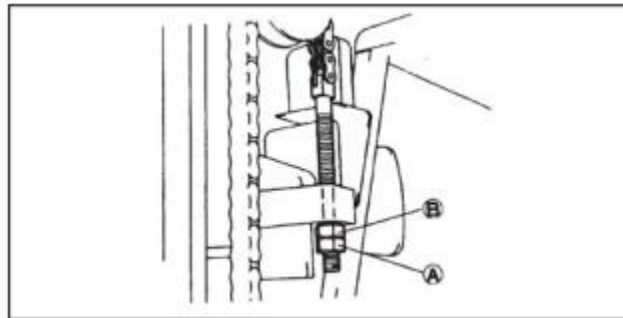

Raise the forks 1.9 in off the ground and check that both lift chains have equal tension. If uneven, adjust using the chain anchor bolt and tighten the lock nut securely.

20. Steering Wheel

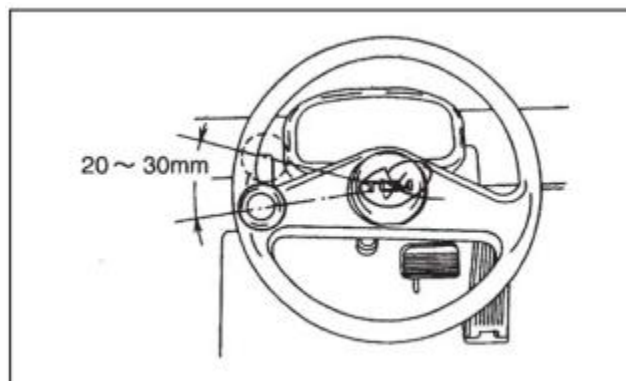

Turn the steering wheel fully left and right. Play should be within 0.7–1.1 in (20–30 mm). Ensure the wheel does not move vertically.

21. Brake Test



Drive the truck slowly and press the brake pedal to confirm smooth braking. Ensure the brake lamps illuminate when the pedal is applied.

22. Steering Wheel Test

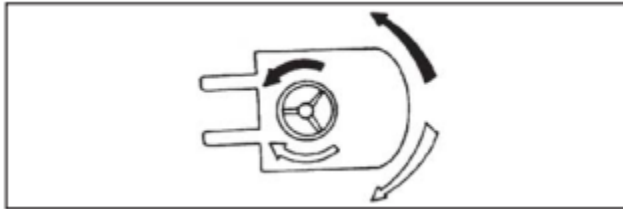

At low speed, turn the steering wheel slightly left and right. Verify that steering is smooth and responsive without abnormal resistance.

23. Parking Brake Test

Pull the parking brake lever and check that the truck stops and remains stationary. The lever should stay locked in position.

24. Backup Light

Shift the change lever into reverse and confirm that the backup light turns on.

Replacing Tires and Repairing Flat Tires

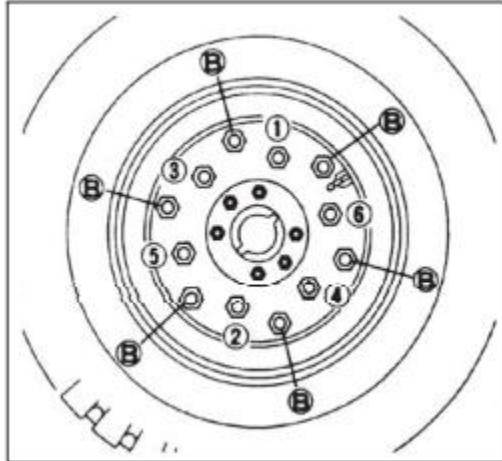

Gather the necessary tools and jack before starting. When removing a tire, first release all air pressure completely, then remove the hub nuts.

1. Park the truck on a level, hard surface with no load on the forks.
2. Apply the parking brake and block the wheels.
3. Jack up the truck slightly so the tire remains on the ground, then loosen the hub nuts.
4. Raise the truck until the tire clears the ground and remove the nuts.
5. Remove the tire from the hub.
6. Reinstall in reverse order, tightening the hub nuts diagonally and evenly to the specified torque (see page 4-4). After installation, adjust tire pressure to the standard level.

For rear tires, follow the same procedure but place the jack under the counterweight.

⚠ CAUTION Always remove air from the tire completely before loosening hub nuts. Failure to do so may cause serious injury.

⚠ WARNING Tire servicing requires proper training. Never loosen wheel assembly bolts until all air pressure is released. Inflate tires only in a safety cage and follow the operator's manual for correct procedures and pressures. Improper servicing can cause severe injury or death.



Removing a Tire from the Rim

⚠ CAUTION Before removing a tire, release all air pressure by removing the valve core. For split-rim types, remove air before loosening the connecting bolts; for side-ring types, remove air before taking off the ring. Tire assembly, disassembly, and inflation must be performed only by qualified personnel using proper tools and safety equipment. Lift-truck tires operate at much higher pressures than passenger-car tires—improper procedures can cause serious injury. Always inflate tires while mounted on the truck or inside a safety cage. Tighten split-rim bolts to the specified torque only after pressure is fully released.

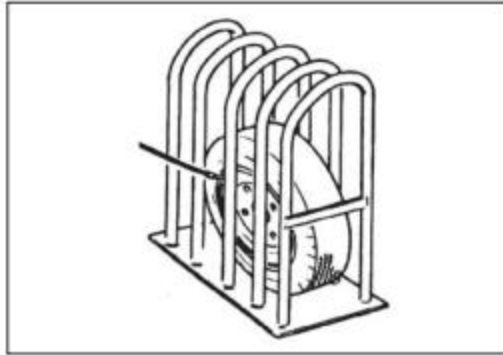
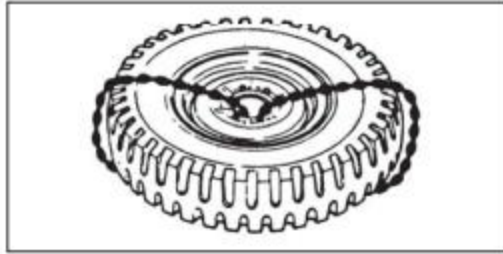

Adjusting Operating Force of Parking Brake

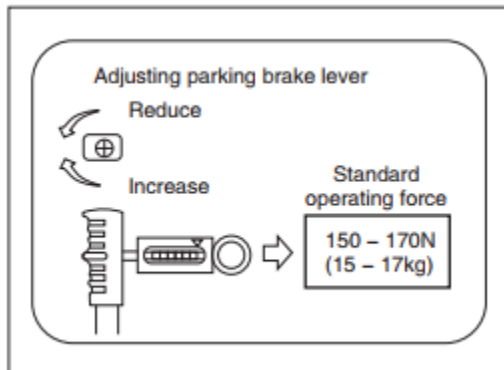
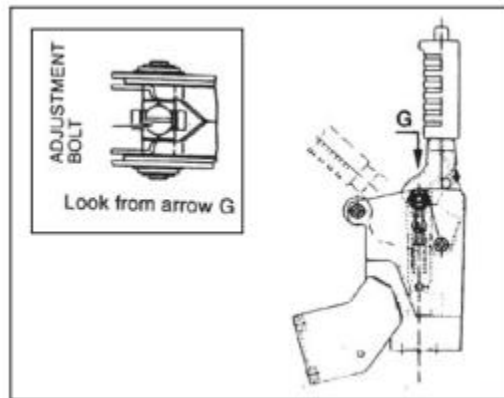

Attach a spring scale to the parking brake lever and measure the force required to operate it. **Standard operating force:** 150 – 170 N (15 – 17 kg). If the force is outside this range, adjust by turning the bolt:

- **Clockwise** to increase force
- **Counterclockwise** to reduce force

New cables may stretch slightly; recheck and adjust after each shift or day’s operation.

PERIODICAL CHECK

⚠ CAUTION Always review the *Inspection and Maintenance* section before performing any service. Periodical checks keep the truck safe and reliable. Operating a damaged or abnormal truck can cause serious accidents. Detecting issues early improves efficiency, extends service life, and reduces maintenance costs. Routine checks such as oil and grease supply and filter cleaning should be done by the operator. Complex inspections must be performed by qualified technicians using proper tools. Each month of operation equals approximately 200 hours.

Periodical Replacement of Safety Parts

No. Safety Part	Recommended Replacement Interval
1 Cups and dust seals of master and wheel cylinders	1 year
2 Power steering hose	2 years
3 Reserve tank tubing	2 – 4 years
4 Steering actuator rubber boots	2 years
5 Lift chain	2 – 4 years
6 Load-handling hoses	1 – 2 years

Preventive maintenance is essential for safe operation. The listed parts must be replaced periodically because they directly affect operator safety. These components deteriorate over time and may appear serviceable even when they are not. Replace them once their service limits are reached or immediately if any abnormality is found.

NOTE Replacement of safety parts is not covered under warranty.

Weekly (50 Operating Hours) Checks Perform these checks in addition to daily preoperational inspections. Weekly checks should be done by the operator of the battery-powered truck to ensure safe and efficient operation.

Items to Be Checked

- Clean the battery.
- Measure and adjust the battery’s specific gravity and electrolyte temperature.

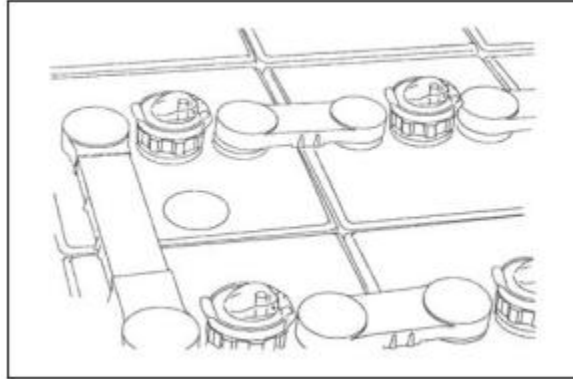

Cleaning the Battery

⚠ CAUTION Do not clean the battery with a dry or chemical cloth—it may cause static electricity and explosion. Always use a damp cloth.

Keep the top surface and joints of the battery clean and dry. Tighten all plugs securely after cleaning.

Monthly (200 Operating Hours) Checks Perform these checks in addition to preoperational and weekly inspections. Monthly checks require technical skill and proper tools; they should be done by qualified personnel.

Items to Be Checked

Electrical and Power Systems

- Battery – Equalizing charge
- Battery receptacles – Damage or looseness
- Wiring – Damage or discoloration
- Contactors – Surface condition of contact points
- Controller – Clean and check for loose connections
- Battery charger – Proper operation
- Fuses – Correct rating and installation

Axles and Steering

- Front axle – Oil leaks
- Front axle mount bolts – Tightness (first inspection only)
- Tires – Tread depth and foreign material
- Front and rear axles – Cracks, deformation, or damage

- Steering gear box – Mounting bolt tightness
- Rods, arms, and king pins – Looseness, bending, or damage

Hydraulic and Brake Systems

- Rear axle – Proper installation
- Brake piping – Air mixing, leaks, or damage
- Brake system – Smooth operation of rods and cables
- Brake fluid – Leaks
- Brake drum – Secure mounting

Mast and Load Handling

- Forks – Cracks or wear
- Mast – Cracks or damage
- Mast support – Cap bolts (first inspection only)
- Lift cylinder bolts and pins – Tightness (first inspection only)
- Lift bracket – Cracks or damage
- Rollers and pins – Looseness or cracks
- Lift chains – Lubrication, tension, and elongation
- Anchor pins – Tightness

Hydraulic Components

- Pumps – Operation and leaks
- Valves – Lever tightness and micro-switch function
- Relief and tilt-lock valves – Proper operation
- Hydraulic piping – Leaks or damage

Items to Be Checked

- **Sheaves** – Operation, damage, and looseness
- **Rollers (end, side, and retaining)** – Operation, looseness, and damage
- **Cylinders (lift and tilt)** – Operation and oil leaks
- **Attachments** – General condition and installation

- **Major bolts and nuts** – Retightening (new loaders only)
- **Chassis** – Lubrication

Lubricating Lift Chain

Apply engine oil to the lift chains using a lubricator or brush. To ensure oil penetrates between each pin and link plate:

1. Loosen the chain slightly.
2. After applying oil, raise and lower the mast fully at least 10 times.

NOTE If the truck operates near coastal or humid areas, lift chains may corrode from salt exposure. After storms or typhoons, rinse chains with fresh water before lubricating.

Greasing points

Mast and Steering System

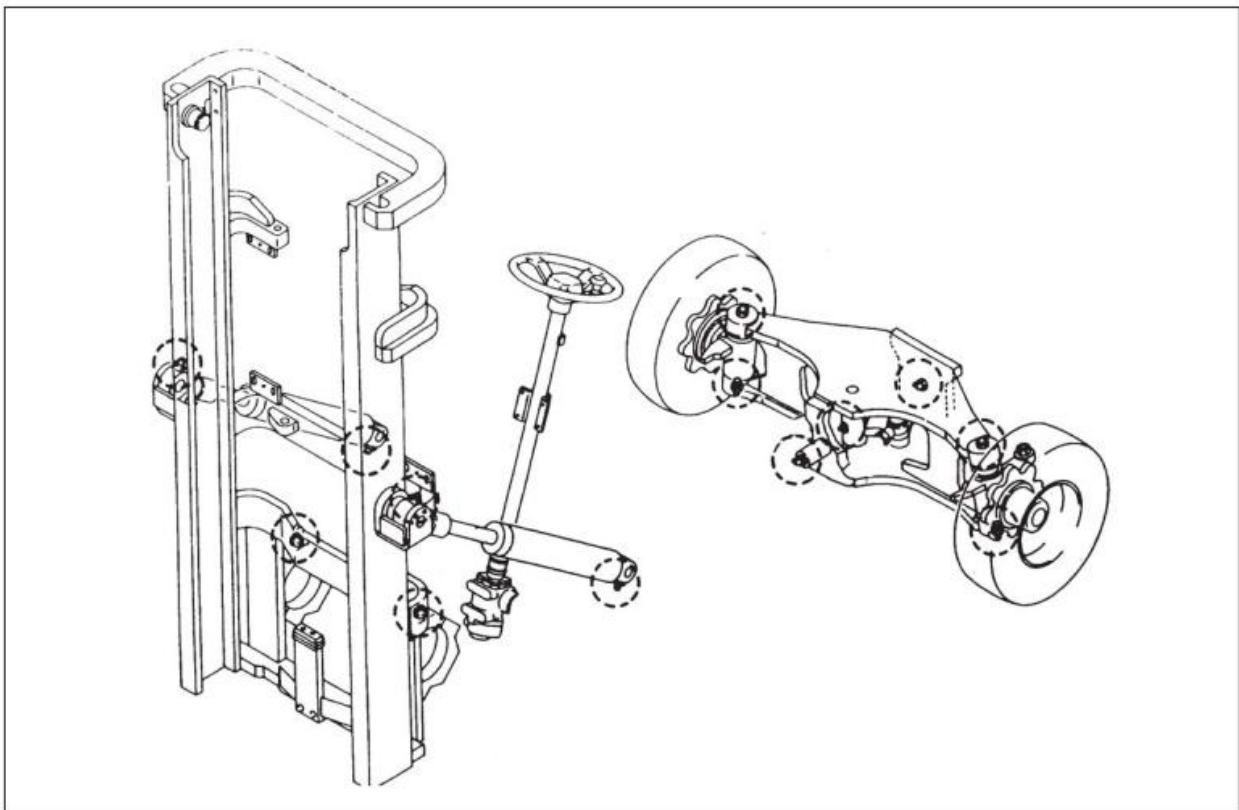

Mast Rear Slipper (for Optional Mast)

⚠ WARNING Do not climb the mast or place hands or feet on connecting members or inside the mast assembly. Accidental mast movement can cause serious injury.

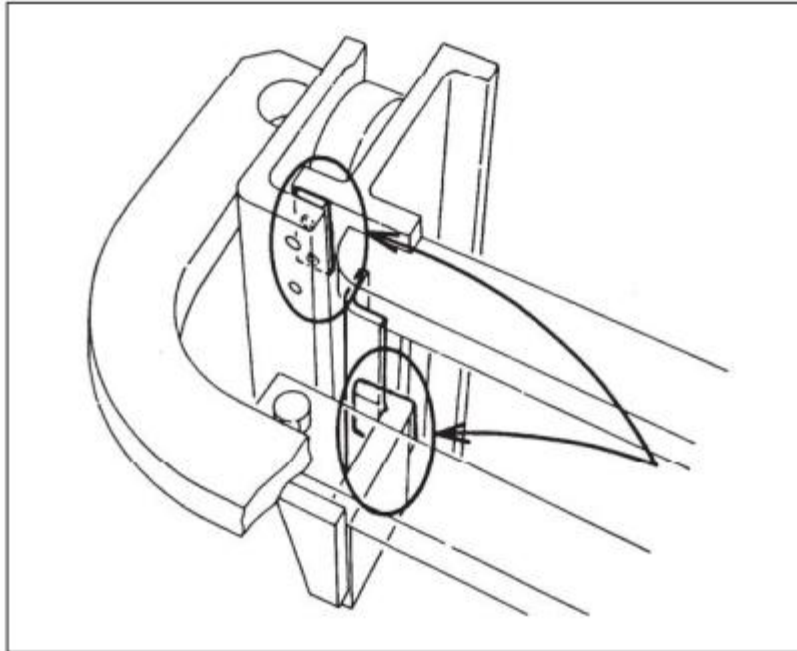

Apply grease to the U-shaped guides shown in the illustration (for masts equipped with a free-lift mechanism). Proper lubrication ensures smooth mast operation and prevents wear on sliding components.

3 Months (600 Operating Hours) Checks

Perform these checks in addition to daily, weekly (50 hours), and monthly (200 hours) inspections. These ensure safe operation and prevent mechanical failure.

Items to Be Checked

- Steering gear case – Check for oil leakage and looseness of mounting bolts.
- Gear box – Inspect for oil leakage and loose mounting bolts.
- Fork stopper pin – Check for damage or wear.
- Motors (pump and power steering) – Inspect brush wear and commutator surface condition.

6 Months (1200 Operating Hours) Checks

Perform these checks in addition to preoperational, weekly (50 hours), monthly (200 hours), and 3-month (600 hours) inspections. These ensure safe, efficient, and reliable operation.

Items to Be Checked

- Contactors – Inspect contact points for wear and replace if necessary.
- Drive motor – Clean and adjust lock current.

- Electrical equipment – Check insulation condition.
- Battery charger – Verify voltage relay operation and adjust voltage.
- Battery charger electronic timer – Confirm proper operation and adjustment.
- Steering gear case – Change oil.
- Hydraulic oil tank – Clean suction strainer.
- Hydraulic oil – Replace.
- Hydraulic system – Replace return filter.
- Relief valve – Adjust relief pressure.
- Mast support – Check for loose cap bolts.
- Accelerator pedal – Adjust stopper.
- Driver’s seat – Inspect for damage and tighten mounting bolts.
- Major bolts – Retighten.

Annual (2400 Operating Hours) Checks

Perform these checks in addition to preoperational, weekly (50 hours), monthly (200 hours), 3-month (600 hours), and 6-month (1200 hours) inspections. Annual checks ensure long-term reliability and safe operation.

Items to Be Checked

- Parking brake – Inspect operation, wear, and ratchet condition.
- Brake fluid – Replace.
- Master and wheel cylinders – Check operation, oil leaks, and damage.
- Master and wheel cylinders – Replace piston cups and check valves.
- Wheel brake – Disassemble, inspect, adjust, and replace brake drums and shoes as needed.
- Mast support – Inspect bushings for wear or damage.
- Lift cylinder – Check for natural drop.
- Tilt cylinder – Check for natural drop.
- Forks – Inspect color and bent areas for signs of stress or deformation.

- Truck body frame and cross members – Inspect for cracks, damage, and loose rivets or bolts.

Periodical Check Schedule

This schedule assumes the lift truck operates under normal working conditions. If used in severe environments, inspections must be performed more frequently. Black dots in the maintenance table indicate items that require replacement or replenishment.

Electric System

ELECTRIC SYSTEM

Checking item	Service Required	Tool/remedy	Before work or shift	Weekly (50 hrs)	Monthly (200 hrs)	Trimonthly (600 hrs)	Semiannually (1200 hrs)	Annually (2400 hrs)
Battery (EXB option)	Check for contamination of battery case	Cleaning		○	○	○	○	○
	Check electrolyte level.	Add if necessary	○	○	○	○	○	○
	Check specific gravity	Adjust		○	○	○	○	○
	Give equalizing charge				○	○	○	○
	Check for insulation	Check				○	○	○
Controller	Check for contamination of the surface	Cleaning			○	○	○	○
	Check for rough contact points of contactor	Check			○	○	○	○
	Check for worn contact points of contactor	Replace if needed					○	○
	Check for insulation	Replace if needed					○	○
Motors (drive, pump, and power steering)	Check for loose connections	Check			○	○	○	○
	Check brushes for wear	Replace if needed				○	○	○
	Check for roughness of commutator	Adjust				○	○	○
	Check for proper operation	Check				○	○	○
	Check for noise	Check				○	○	○
	Check lock current (for drive motor)	Measure and adjust					○	○
	Check for insulation	Measure				○	○	○
Battery charger (EXB option)	Check for contamination	Cleaning					○	○
	Check for proper operation (lamps)	Check				○	○	○
	Check for proper operation and voltage of voltage relay	Adjust				○	○	○

Checking item	Service Required	Tool/remedy	Before work or shift	Weekly (50 hrs)	Monthly (200 hrs)	Trimonthly (600 hrs)	Semiannually (1200 hrs)	Annually (2400 hrs)
Battery charger (EXB option)	Check for insulation	Adjust				○	○	○
	Check for proper operation of magnet switch	Adjust						○
	Check electronic timer for operation	Adjust				○	○	○
Wiring, terminals, receptacles, couplers	Check for looseness	Retighten	○	○	○	○	○	○
	Check for damage	Check	○	○	○	○	○	○
	Check for discoloration	Check			○	○	○	○

POWER TRAIN

Checking item	Service Required	Tool/remedy	Before work or shift	Weekly (50 hrs)	Monthly (200 hrs)	Trimonthly (600 hrs)	Semiannually (1200 hrs)	Annually (2400 hrs)
Front axle	Check for oil leaks	Visual	○	○	○	○	○	○
	Check oil level	Visual			○	● (1st time only)	●	●
	Check mount bolts for looseness	Test hammer			○	○	○	○

STEERING SYSTEM

Checking item	Service Required	Tool/remedy	Before work or shift	Weekly (50 hrs)	Monthly (200 hrs)	Trimonthly (600 hrs)	Semiannually (1200 hrs)	Annually (2400 hrs)
Tires	Check inflation pressure	Tire gauge	○	○	○	○	○	○
	Check tires for cracks	Visual	○	○	○	○	○	○
	Check for wear	Depth gauge			○	○	○	○
	Check tires for undue wear	Visual	○	○	○	○	○	○
	Check tires for spikes, stones or foreign matter	Check			○	○	○	○
Tire fasteners (hub, rim mounting bolts, nuts)	Check for looseness	Test hammer	○	○	○	○	○	○
	Check for damage	Visual	○	○	○	○	○	○

STEERING SYSTEM

Checking item	Service Required	Tool/remedy	Before work or shift	Weekly (50 hrs)	Monthly (200 hrs)	Trimonthly (600 hrs)	Semiannually (1200 hrs)	Annually (2400 hrs)
Rims and side rings	Check for damage of rims, side rings, and disk wheels	Visual	○	○	○	○	○	○
Wheel bearings	Check for looseness and noise				○	○	○	○
	Disassemble wheel bearings and change grease						●	●
Axle	Check for deformation, cracks and damage.	Visual			○	○	○	○

CONTROLS

Checking item	Service Required	Tool/remedy	Before work or shift	Weekly (50 hrs)	Monthly (200 hrs)	Trimonthly (600 hrs)	Semiannually (1200 hrs)	Annually (2400 hrs)
Steering wheel	Check for play	Operate	○	○	○	○	○	○
	Check for looseness in axial direction	Touch	○	○	○	○	○	○
	Check for looseness in radial direction	Touch	○	○	○	○	○	○
	Check for proper operation	Operate	○	○	○	○	○	○
Steering gear box	Check for loose mounting bolts	Operate			○	○	○	○
Rod, arm	Check for looseness	Operate			○	○	○	○
	Check for bends, damage or wear	Visual			○	○	○	○
Knuckle	Check for looseness and damage of king pin	Operate			○	○	○	○
Rear axle	Check for bends, deformation, cracks or damage	Visual			○	○	○	○
	Check for mounting condition	Test hammer			○	○	○	○
Power steering	Check for proper operation	Operate	○	○	○	○	○	○
	Check boots for rupture	Visual		○	○	○	○	○
	Check for loose mounting or linkage	Visual			○	○	○	○
	Check ball joints	Touch			○	○	○	○

BRAKE SYSTEM

Checking item	Service Required	Tool/remedy	Before work or shift	Weekly (50 hrs)	Monthly (200 hrs)	Trimonthly (600 hrs)	Semiannually (1200 hrs)	Annually (2400 hrs)
Brake pedal	Check for play	Operate	○	○	○	○	○	○
	Check for pedal travel	Scale	○	○	○	○	○	○
	Check for braking effect or uneven braking	Operate	○	○	○	○	○	○
	Check for air mixed in brake piping	Operate			○	○	○	○
Parking brake lever	Check for proper operation of lever	Operate	○	○	○	○	○	○
	Check for braking effect	Operate	○	○	○	○	○	○
Rod and cable	Check for proper operation	Operate			○	○	○	○
	Check for loose linkage	Touch			○	○	○	○
Hose and pipe	Check for damage, leaks or intervention	Visual			○	○	○	○
	Check for loose connections or clamp	Touch			○	○	○	○
Oil brake	Check for fluid leaks.	Visual			○	○	○	○
	Check for fluid level and add, if needed.	Visual	○	○	○	○	●	●
	Check master cylinder and wheel cylinders for proper operation.	Operate						○
	Check master cylinder and wheel cylinders for fluid leaks or damage.	Visual						○
	Check master cylinder piston cup and check valve for wear or damage.	Disassembly						●
Brake drum & shoe	Check drum mounting part for looseness.	Test hammer			○	○	○	○
	Check linings for wear.	Slide calipers						○
	Check shoes for proper operation.	Operate						○
	Check anchor pins for rust.	Visual						○
	Check return springs for deterioration.	Scale						○
	Check automatic adjuster for proper operation.	Operate						○
	Check drum for wear or damage.	Visual						○

ELECTRIC SYSTEM

Checking item	Service Required	Tool/remedy	Before work or shift	Weekly (50 hrs)	Monthly (200 hrs)	Trimonthly (600 hrs)	Semiannually (1200 hrs)	Annually (2400 hrs)
Back plate	Check for deformations	Visual						○
	Check for cracks	Visual						○
	Check installation for looseness	Test hammer						○

LOAD HANDLING SYSTEM

Checking item	Service Required	Tool/remedy	Before work or shift	Weekly (50 hrs)	Monthly (200 hrs)	Trimonthly (600 hrs)	Semiannually (1200 hrs)	Annually (2400 hrs)
Forks	Check for damage, deformation, or wear	Visual	○	○	○	○	○	○
	Check fork stopper pin for damage or wear	Visual				○	○	○
	Check fork roots and teeth—welded area for cracks or wear	Visual				○	○	○
Mast and carriage	Check mast cross members for cracked weld or damage	Visual			○	○	○	○
	Check tilt cylinder bracket and mast for cracks or damage at welded parts	Visual			○	○	○	○
	Check outer and inner masts for cracked weld or damage	Visual			○	○	○	○
	Check carriage for cracked weld or damage	Visual			○	○	○	○
	Check roller bearing for looseness	Touch			○	○	○	○
	Check mast support bushing for wear or damage	Visual					○	○
	Check for mast support bushing bolts for looseness	Test hammer				○(1st/time only)		○
	Check rollers, roller pins and weld for cracks or damage	Visual				○	○	○
Chain and sheave	Check for looseness of lift cylinder tail bolts, piston rod head bolts, U bolts, piston head guide bolts	Test hammer		○(1st/time only)			○	○
	Check chain for tension, deformation, damage or corrosion	Touch	○	○	○	○	○	●(2 or 4)years
	Check chains for lubrication	Visual			○	○	○	○
	Check for elongation	Gauge			○	○	○	○

LOAD HANDLING SYSTEM

Checking item	Service Required	Tool/remedy	Before work or shift	Weekly (50 hrs)	Monthly (200 hrs)	Trimonthly (600 hrs)	Semiannually (1200 hrs)	Annually (2400 hrs)
Chain and sheave	Check loose linkage of chain anchor pin and chain	Visual			○	○	○	○
	Check sheaves for deformation or damage	Visual			○	○	○	○
	Check sheave bearings for looseness	Touch			○	○	○	○
Attachments	Check for operation and installation	Operate/visual			○	○	○	○
Cylinder	Check piston rod, rod bolt, rod end for looseness deformation and damage	Visual/test hammer	○	○	○	○	○	○
	Check for proper operation	Operate	○	○	○	○	○	○
	Check for oil leaks	Visual	○	○	○	○	○	○
	Check pin and cylinder bushing for wear or damage	Visual			○	○	○	○
Hydraulic pump	Check for oil leaks or noise	Visual/auditory	○	○	○	○	○	○

HYDRAULIC SYSTEM

Checking item	Service Required	Tool/remedy	Before work or shift	Weekly (50 hrs)	Monthly (200 hrs)	Trimonthly (600 hrs)	Semiannually (1200 hrs)	Annually (2400 hrs)
Hydraulic oil tank	Check oil level and change oil if contaminated	Visual	○	○	○	○	●	●
	Change suction strainer	Operate					○	○
Inline filter	Change filter cartridge	Operate					●	●
Control valve lever	Check for operation of control lever linkage	Operate	○	○	○	○	○	○
	Check for function of control lever	Operate	○	○	○	○	○	○
Control valve	Check for oil leaks	Visual	○	○	○	○	○	○
	Check relief valve, tilt lock valve for operation	Auditory			○	○	○	○
	Measure relief pressure	Oil pressure gauge					○	○
Hose, piping, hose reel, and swivel joint	Check for oil leaks, looseness, deformation and damage	Visual/auditory	○	○	○	○	○	○
	Check load handling system hoses	Operate						●(2 or 4)years

SAFETY DEVICE AND OTHERS

Checking item	Service Required	Tool/remedy	Before work or shift	Weekly (50 hrs)	Monthly (200 hrs)	Trimonthly (600 hrs)	Semiannually (1200 hrs)	Annually (2400 hrs)
Overhead guard and load backrest	Check for loose mounting	Test hammer	○	○	○	○	○	○
	Check for deformation, cracks or damage	Visual	○	○	○	○	○	○
Turn signal	Check for operation and installation	Operate	○	○	○	○	○	○
Alarm	Check for operation and installation	Operate	○	○	○	○	○	○
Lights	Check for operation and installation	Operate	○	○	○	○	○	○
Back-up alarm	Check for operation and installation	Operate	○	○	○	○	○	○
Sideview mirrors	Check for contamination or damage	Visual	○	○	○	○	○	○
	Check for proper visibility	Visual	○	○	○	○	○	○
Meters	Check for operation	Operate	○	○	○	○	○	○
Rear reflector/ License number plate	Check for contamination or damage	Visual	○	○	○	○	○	○
Driver's seat	Check for damage or loose mounting bolts	Visual					○	○
Truck body	Check frame and cross members for damage or cracks	Visual						○
	Check for loose rivets and bolts	Test hammer						○
	Check the results of previous checks	Visual	○	○	○	○	○	○
	Check general condition of truck	Visual	○	○	○	○	○	○
Lubricants and oil change	After cleaning, check for lubrication of each part	Grease pump			○	○	○	○
	Check condition of lubricants	Check						○

Specifications

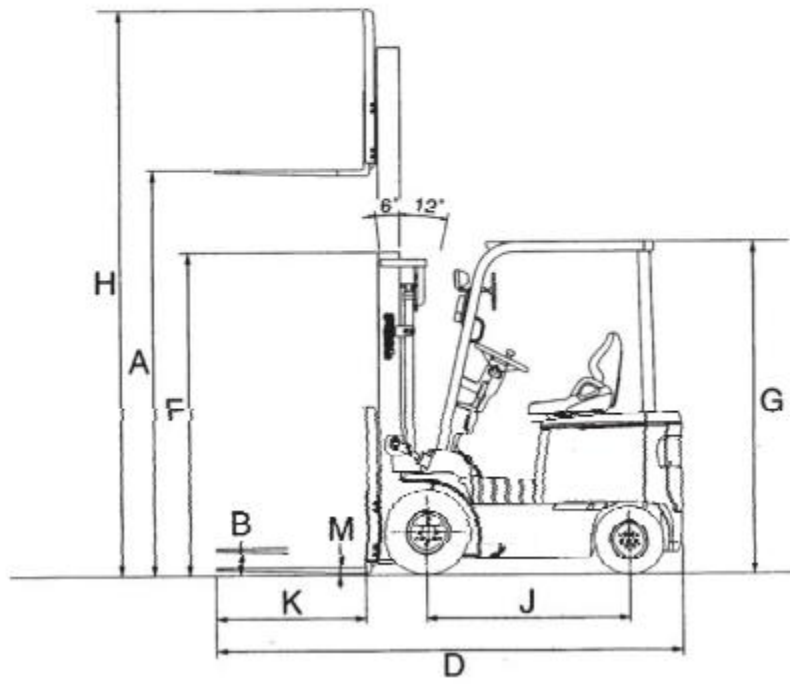
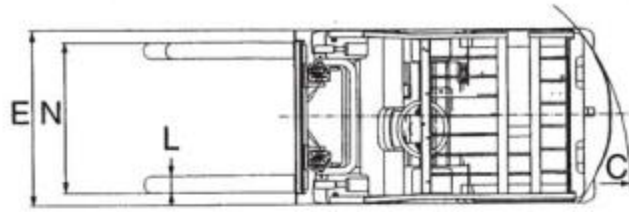

⚠ CAUTION

The load charts below refer to the lift trucks of standard specifications, and those with high mast whose lifting height is less than 5m. Lift trucks with a high mast whose lifting heights is 5m or higher, or those with an attachment have different load charts.

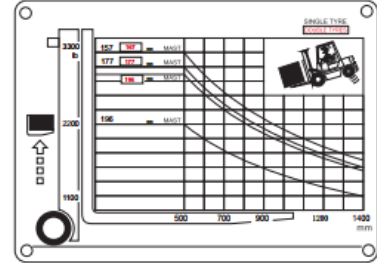
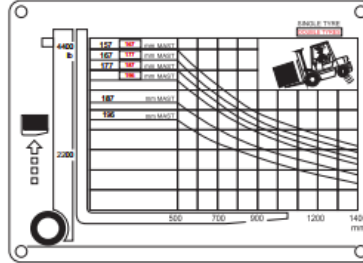
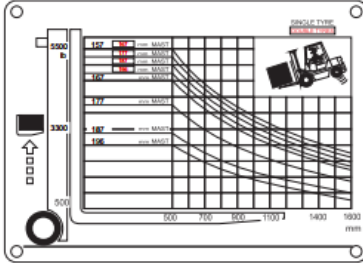

SERVICE DATA

Brake Pedal

- Height: 90 mm
- Pedal play: 5 mm

Parking Lever

- Operating force: 150 – 170 N (15 – 17 kg)

Tightening Torque of Bolts and Nuts

Component	Torque
Rear axle (axle – frame)	427 – 634 N·m (43.1 – 64.7 kg·m)
Mast support (mast – frame)	75 – 111 N·m (7.6 – 11.3 kg·m)
Piston head guide mounting bolt	134 – 200 N·m (13.6 – 20.4 kg·m)

Control Valve

- Relief set pressure: FB15/18 – 14.2 MPa (145 kg/cm²) FB20/25 – 14.2 MPa (145 kg/cm²)

Replacing Light Bulbs

Replace any blown bulb with one of the specified capacity.

Lamp	Capacity
Headlights	48 V – 40 W

Lamp	Capacity
Clearance lights	48 V – 25 W
Turn signals (front/rear)	48 V – 25 W
Tail lights	48 V – 10 W
License plate lamp (option)	48 V – 10 W
Rear work light (option)	48 V – 40 W
Brake light	48 V – 25 W
Backup light	48 V – 10 W

Fuse Capacity

Fuse	Function	FB15/18	FB20/25
F1	Traveling inverter	275 A	325 A
F2	Hydraulic pump circuit inverter	225 A	225 A
F3	EPS circuit	40 A	40 A
F4	48 V control power supply	10 A	10 A
F5	Lamp circuit	10 A	10 A
F6	Battery charger output circuit	130 A	130 A
F7	70 V control power supply	—	—

Consult your authorized service dealer for fuse replacement.

Battery Charging Time (Standard)

Truck-mount battery charger (EXB Option)

48 V Battery

Charger Model Battery Capacity (AH/5H) Standard Charging Time (H)

M80B, C, D	330	8.5
	400	10

Charger Model Battery Capacity (AH/5H) Standard Charging Time (H)

	485	11.5
M115B, C, D	450	8.5
	545	10
	565	10.5
	600	11
M160B, C, D	700	12.5
	865	10.5
	935	11.5

72 V Battery

Charger Model Battery Capacity (AH/5H) Standard Charging Time (H)

N105B, C, D	450	9
	545	10.5

Input Voltage Range

Mode Frequency Voltage Range

B Mode	60 Hz	195 – 215 V
	50 Hz	190 – 210 V
C Model	60 Hz	370 – 410 V
	50 Hz	360 – 400 V
D Model	60 Hz	420 – 460 V
	50 Hz	410 – 450 V

Note: If the supply voltage of your charging facility is outside the specified range, adjust the tap setting accordingly.

Diagnostics

Display

Details

How to Reset

Flashing (0.5-second intervals)

Drive motor overheating / Pump motor overheating

Turn the key OFF, then ON. Allow the system to cool.

Flashing (0.3–0.5-second intervals)

Controller overheating

Turn the key OFF, then ON. Lower the temperature.

Flashing (0.5-second intervals)

Pump motor brush wear

Replace brushes.

Flashing

Low battery fluid level / Battery warning

Refill battery fluid.

Flashing

Neutral safety warning

Return the shift lever to neutral.



If any of the following codes appear on the LCD, contact your authorized service dealer.

Item	Truck model	Capacity (liter)		Ambient Temperature at Starting	Grade of Viscosity API Class	Brand of Lubricant Specified		
		EK40T-LI	EK25T-LI			Mobil	Shell	Esso
1	Hydraulic oil tank	40	25	higher than -25°C	ISO VG32	Mobil DTE Oil Light	Shell Tellus Oil C-32	Teresso 32
				higher than -40°C	ISO VG22	Mobil DTE 24	Shell Tellus Oil 32	Nuto HP-32
2	Reduction gear/differential	5	5	-25 – 35°C	SAE 10W-30 CC	Mobil Delvac 1100 or 1200	Shell Rotella	Esso Lube HDX 10W-30
				-25 – 0°C	SAE 10W CD	Mobil Delvac 1310	Shell Rotella TX Oil 10W	Esso Lube D-3 10W
				higher than 0°C	SAE 30 CD	Mobil Delvac 1330	Shell Rotella TX Oil 30	Esso Lube D-3 SAE 30
3	Brake fluid reservoir tank	0.2		—	FMVSS DOT-3	Mobil Super Heavy Duty Brake Fluid	See Note 2	See Note 2
4	Greasing points	Proper amount		higher than -40°C	NLG1 No.1 or 2	Mobil grease JL (2)	Albania grease (1,2)	Beacon (2)

Notes

1. The listed temperatures refer to ambient conditions at engine start.

2. For detailed lubricant recommendations, contact your authorized dealer.

Serial Numbers of Major Components

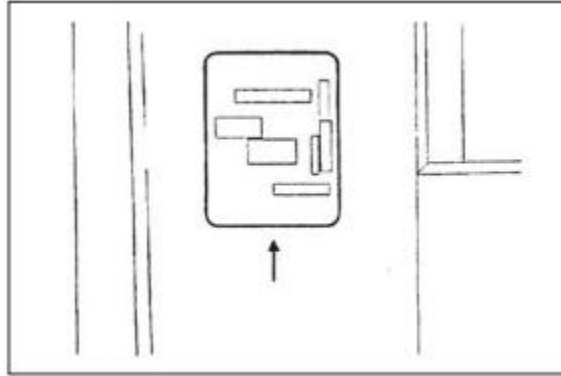

Each lift truck has a serial number plate, and major components (such as the mast) also have individual serial or unit numbers stamped or labeled on the truck. Record these numbers and retain them for future maintenance and parts replacement. The illustration shows the location of the mast serial number plate.

Genuine Parts

Even high-quality equipment deteriorates over time. To maintain optimal performance and safety, always use genuine replacement parts identical to those installed on new trucks. When ordering, specify genuine parts to ensure compatibility and reliability.

Genuine Lubricants

Use only genuine lubricants for all lubrication points to maintain proper function and extend component life.

EKKO Material Handling Equipment

Thank you for choosing EKKO Material Handling Equipment. Your commitment to proper maintenance and safe operation ensures long-term performance, reliability, and operator safety.

For technical support, service assistance, or genuine replacement parts, contact your authorized EKKO dealer.

EKKO Material Handling Equipment 1761 W. Holt Ave. Pomona, CA 91768 USA

All specifications and information in this manual are subject to change without notice. Use only genuine EKKO parts and approved lubricants to maintain product integrity and warranty compliance.

Last Revised: June 2026