



The Specification

EB12E-138 Series Full Electric Straddle Stacker

Note: Before using, please read this manual!



EKKO Material Handling Equipment Manufacturing, Inc.

Contents

1. The correct use of Electric stacker - 3 -

2. Warning,the residual risk and safety instructions - 7 -

3. Commissioning, transport, outage - 7 -

4. Daily inspection - 9 -

5. Operating instructions..... - 9 -

6. Battery charging and replacement..... - 12 -

7. Regular maintenance - 13 -

8. Fault analysis..... - 17 -

1. The correct use of electric stacker

Described in this manual of the full electric walkie straddle stacker. This equipment is to reduce the handling and transportation of your load efficiently. Improper use may result in personal injury or damage of the machine.

The operator must ensure proper usage and be authorized and trained before use. This stacker should always be on a flat surface while lifting any material. This stacker should be used in room temperature environments. Not recommended for operation and lifting on slopes. Loads should always be centered within the 24” load center from backrest. It is strictly prohibited to lift or carry personnel. Load of material must be reduced to the max lifting point (138in).

Rated load is in the load curve on the label of the unit. The operator should pay attention to these warnings and safety instructions.

Changing:

Load ratings affect the stability and safety of the operations of this equipment. This includes the effects of the changes, such as: brake, steering, Increase the visibility and mobile accessories. When the manufacturer or its successor approved modify or change, load curve, label, the identification mark, operation and maintenance manuals will be corresponding to the changes. Any changes made or damaged due to misuse of this products will lose the warranty.

1.1An overview of 1.1 main parts

Fig 1: The main component overview

Model		EB12E-138
Load capacity	(lbs)	2640
Load capacity on Max. height (kg)	(lbs)	1540
The max. lifting height	(in)	138
Load center distance	(in)	24
Fork length	(in)	45
Single fork width	(in)	4
Overall fork width	(in)	8.3-33.5
Lowered fork height	(in)	2.35
Fixed leg length	(in)	36.5
Fixed leg width, single (Including the front double frame)	(in)	5
Inside width between fixed legs	(in)	45.5-59.1
Turning radius	(in)	52.6
Front wheel size, number		φ3.1×2.7、 4
Rear wheel size, number		φ8.3×2.7、 1
Balance wheel size, number		φ6×2.3、 1
Overall length	(in)	71
Max Overall width	(in)	61
Extended mast height	(in)	154
Lowered mast height	(in)	92
Battery voltage (dimensions)	(in)	2×12V/100AH (10/6.6/8.5)
The charger	V/A	24V/15A
Lifting Motor	V/Kw	2.2kw. Lift speed, laden/unladen:92/136mm/s Lowering speed: laden/unladen:112/98mm/s
Driving Motor		0.75kw.Driving speed: laden/unladen:4.0/4.2km/h
Service Weight	(lbs)	1450

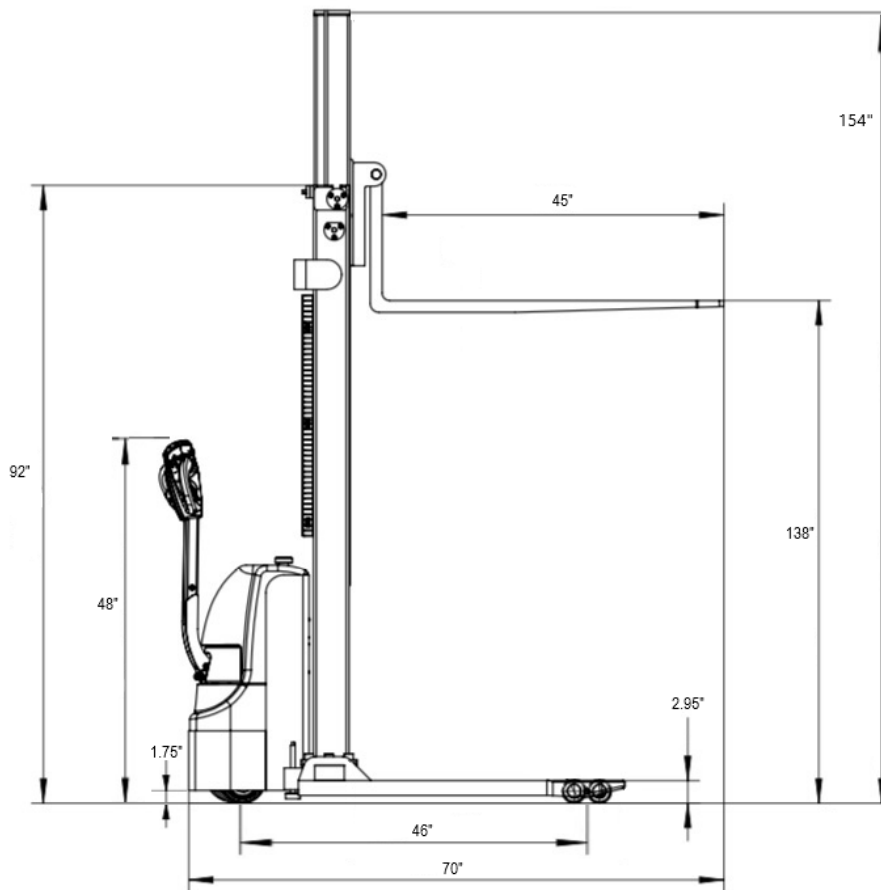

1.3 Optional

C. Safety devices and warning label, description

A The hook label

B The warning label: Do not stand at the fork below or the goods fork

C Load curve icon paste

D Read and observe the instructions of the label

E Data plate

(3) The emergency stop switch

(14) Belly switch

The stacker has an emergency stop switch that stops all functions, lifting and driving functions, and can make the electromagnetic brake engage.

After checking everything and it is safe to do so, pull the red emergency switch back up to engage all

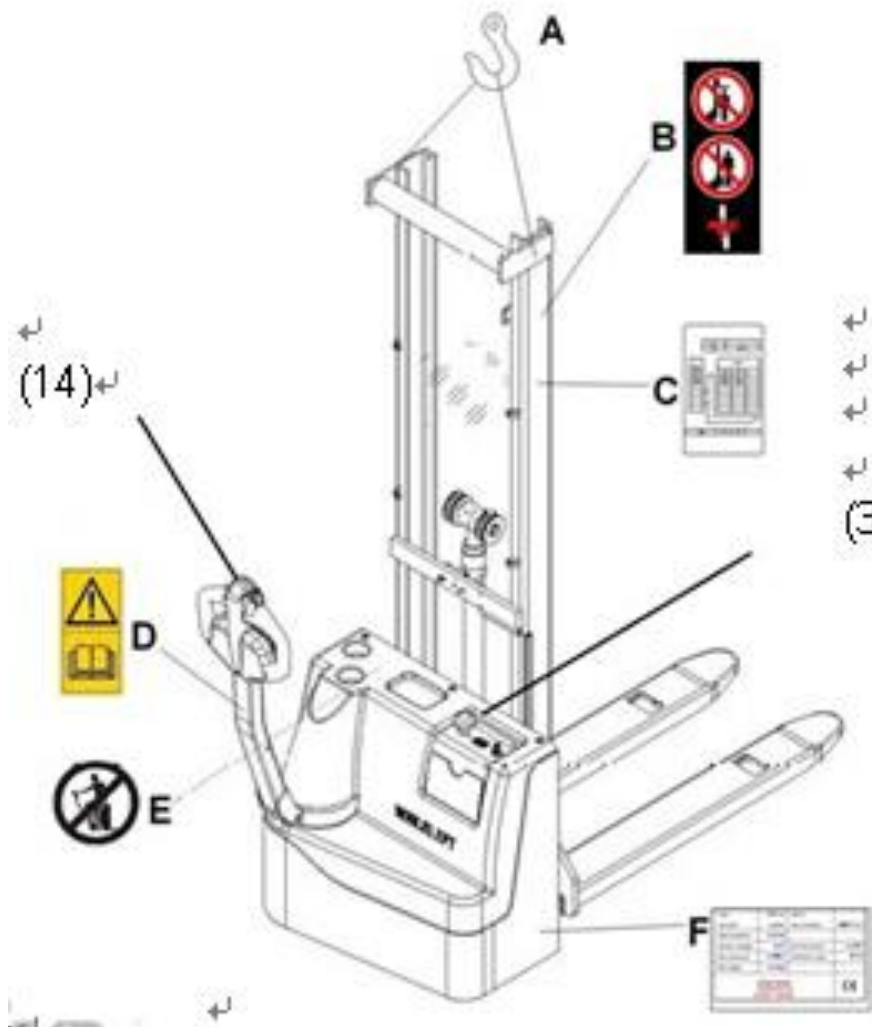

functions.

Insert the key and switch clockwise rotation to power on. Key can be removed to prevent unauthorized users.

This product also has an emergency reverse belly switch (14), this will ensure safety of the operator from running into them. Engagement of the belly switch, which can stop and reverse the product once the belly button is hit and engage for the safety of the operator.

At the same time, follow the instructions on the label as shown.

Fig 3: Safety devices and warning label

D. Data plate

- 1 Name, type
- 2 Serial number
- 3 Rated capacity (ib)

- 7 Minimum / maximum battery weight
- 8 Rated power (kW)
- 9 Load center distance

- 4 Supply voltage (V)
- 5 No battery weight (weight) (ib)
- 6 The name and address of manufacturer

- 10 Manufacturing parameters
- 11 Optional

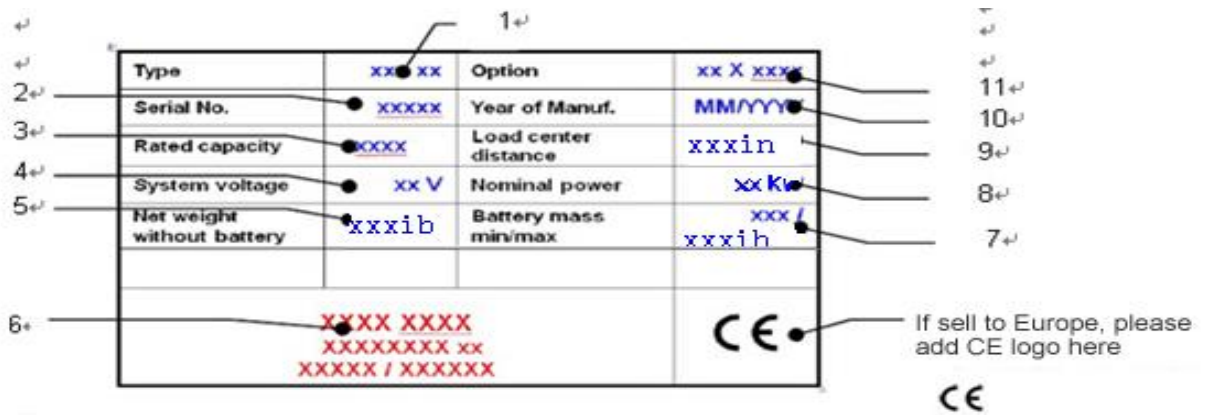

2. Warning, safety instructions

Warning-----Please do not:

1. Travel, with a load above (<11.8in).
2. Avoid putting your foot or hand within any lifting mechanism.
3. Avoid non-operating personnel near the equipment while traveling or lifting / lowering.
4. Avoid your foot in the front of the wheels.
5. Must be cautious when using this equipment on a slope .
6. Lateral load or tail load should be with caution.
8. The goods must be evenly distributed on both forks with center of load at 24” to avoid unstable, and unbalanced loads.

Safety instructions

1. Charging must me AC voltage of 110V outlet or outside the 220V.
2. Observation of different ground level and dips when operating. The goods may tip, or the stacker may lose control. Please check the load from time to time. If the goods become unstable you should immediately stop the operation of the vehicle and re-center or secure it.
3. When the goods on the stacker starts sliding. Immediately press down on the emergency stop switch.
4. Always perform maintenance work according to the regular inspection. Recommended use this stacker in the dry environments for longevity.
5. Always be trained to operate this stacker and wear protective gear and safety shoes.
6. This stacker is suitable for room temperature between +5 C to + 40 C indoor use.
7. Be cautious while operating this on a slope. Sudden movement may cause unexpected stability of the load.

3. Inspection, transport, outage

3.1 Test

Inspecting on receipt of your new stacker, the following steps before operating the equipment: The equipment should be at full charge. (see Chapter sixth) Work according to the inspection and routine inspection of the equipment.

3.2 Lifting / Transport.

When transporting, the removal of the goods, the fork must be lowered to the lowest position, and according to the following chart secure equipment.

Lifting:

Please use the special cranes and lifting equipment;

Please don't stand underneath the stacker;

Please do not have anyone near or stand near the equipment when lifting anything

Strapping or lifting the stacker by its lifting hooks is shown in figure 5 or to tie down the body.

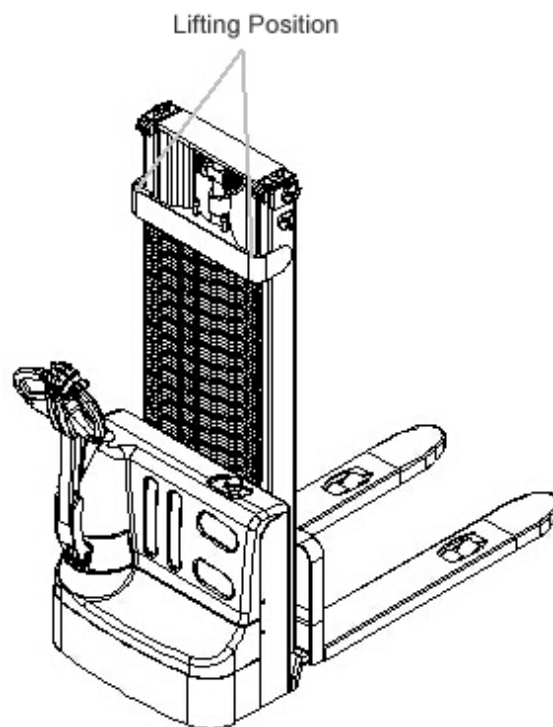

Fig. 5: Used crane hoisting

Transport:

- A. In the process of transportation vehicles must be firmly fixed on truck.
- B. Reduce the fork to the lowest position. Use straps through or on the outriggers/leg

4. Daily inspection

This chapter describes the daily inspection of the equipment and recommended examination before operation.

Daily inspection can prevent faults for failure. The following points should be checked before operating the vehicle.

Check whether there are scratches, deformation or cracks in any welds and structure.

Check the cylinder leaks of hydraulic fluids.

Check the condition of the vehicle longitudinal driving.

Check the chain and the roller for damages or corrosion.

Check the wheels for smooth travel.

Press the emergency stop button to check the emergency braking function.

Brake function check handle lever switch.

Press the button to check for lifting and lowering function.

Check whether there is damage and protective guard is installed correctly.

Check the horns.

All bolts and nuts are tightened.

Check the key switch function.

Check the lifting limit switch.

Visually check whether there is any damage in wiring or hoses.

Check the charge of the equipment

5. Operating Instructions

The operation of this stacker, please follow the warning and safety instructions (see chapter 2).

Make sure there are no goods or other equipment interfering in your visibility!

Insert the key, turn clockwise to turn on.

Make sure the Red Emergency Button is switched on and pulled upwards.

Ready to operate.



5.1 Parking

Not recommended to stop on a slope.

This car is equipped with an electromagnetic fault protection parking and parking brake.

However, please always completely lower the fork at all times. Turn key counterclockwise rotation, then remove the key.

5.2 Load Curve

Load curve shows a given load center C [mm] and horizontal load capacity of the largest load Q [kg] vehicle corresponding lifting height is H [mm].

The white mark on the door frame representation can reach ascension range.

For example: a cargo gravity center distance of C is 24", the maximum lifting height H 138in, the maximum load capacity of Q to 1540lbs.

5.3 Lifting Loads

Do not overload. The maximum load capacity of this car is 1540lbs at max height.

Only increase the load capacity allowed by the load curve.

When traveling, lower the fork to 11.8in to reduce to a car on the leg, and press the lift button (Figure 1, 11) until you reach your expectations lifting height.

5.4 Lowering Loads

Always lower the loads slowly and carefully without any shifting or turning. Carefully press the down button, then carefully pull away from the goods.

5.5 Traveling

Always travel with slower speeds with loads and when going up ramps have the load facing forward.

Travel with caution and awareness of your surroundings.

Always lower your load to a minimum when traveling.

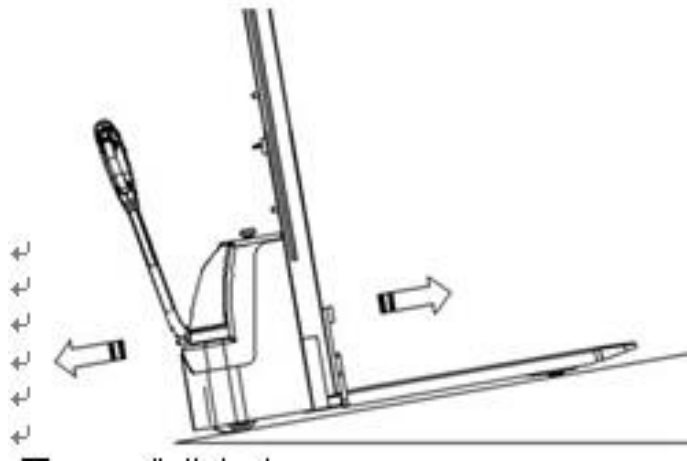

Fig 7: Goods Up

Turn on the equipment with key, pull the emergency button switch upward if not engaged. Raise the forks at a minimum height of at least 3-6 inches off the ground to avoid getting caught up on anything (Figure 11)

Carefully accelerator butterfly throttle on the handle to determine if you are moving forward or backwards. (Figure 12).

If the stacker is stopped, then the electromagnetic braking will engage.

Always be careful driving the stacker to its destination. Always observe your surroundings and the surface you are traveling and accelerate with proper speed.

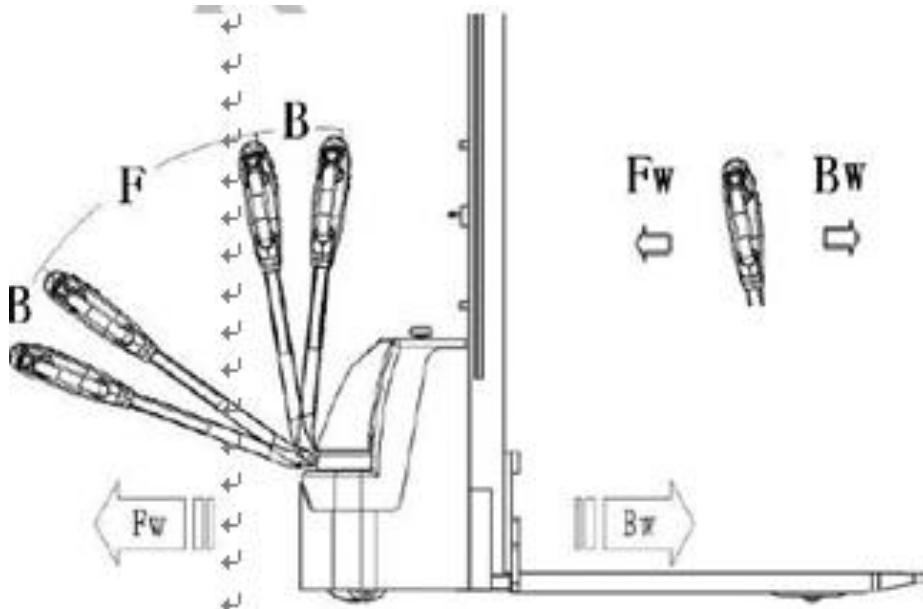

Fig 8: The direction of the operation

5.6. Steering

Steer in the direction with the handle to determine direction.

5.7. Brake

Load braking performance depends on the road conditions and equipment.

Brake function can be activated by the following ways through the accelerator button (12) moved back to '0' position or the release of this button, the regenerative braking is activated.

Through the accelerator button (12) driving direction move directly to the opposite direction from a truck with regenerative braking, until it begins running in the opposite direction.

If the handle is moved upwards or downwards to the braking zone ('B'), truck will stop. If the release lever, is automatically moved to the handle braking area ('B'). The truck will start braking.

Belly button switch (14) can prevent accidents and will stop and reverse once the belly button switch is engaged. If you press this switch, the truck will reverse in opposite direction ('Bw.'), then stop to avoid accidents. If the handle on the operation of the truck is not running, properly, please consider this switch is compressed.

5.8. Fault

If there is any fault or truck is not operating properly, please stop using the truck and press the emergency stop switch (2).

Park the truck in a safe area, turn the ignition off (16) counter clockwise rotation, and then pull out the key.

Immediately inform the manager and / or contact your customer service personnel. If necessary, transport the truck with another lifting equipment to a secure location to diagnose.

5.9 In case of emergency

When you encounter an emergency, press down the emergency stop switch (2). All electrical functions will stop. Keep a safe distance.

6. Battery charging and replacement

1. Only qualified technicians or trained operators should repair or to recharge the battery. Please be sure to abide by the operation manual and battery manufacturer's instructions.
2. These batteries are maintenance free, prohibited to for re-fill.
3. Battery recycling shall abide by state laws and regulations due to hazardous material and chemicals. Please abide by these provisions.
4. Treatment of the battery, the prohibition of the use of fire, gas may cause explosion!
5. Battery charging areas should be free from flammable materials or flammable liquids. Smoking is prohibited, and the area must be well ventilated.
6. Truck must be parked with the equipment with the emergency button off before charging or installing replacement battery.
7. Before performance maintenance, make sure all wiring harness is connected correctly.
8. The truck is equipped with a sealed liquid acid battery 2*12V/ 100Ah.
9. Only allow the use of sealed lead-acid battery for operation of this truck.

Note: Please consider the maximum operating temperature of the battery.

6.1. Replacement

Safety park vehicles, with a key (16) close the stacker and press the emergency stop switch (2). Unscrew the 2 screws on the main cover, remove the main outer cover. First unscrew the

6.2. Power Meter

Discharge with 4 LED display to show

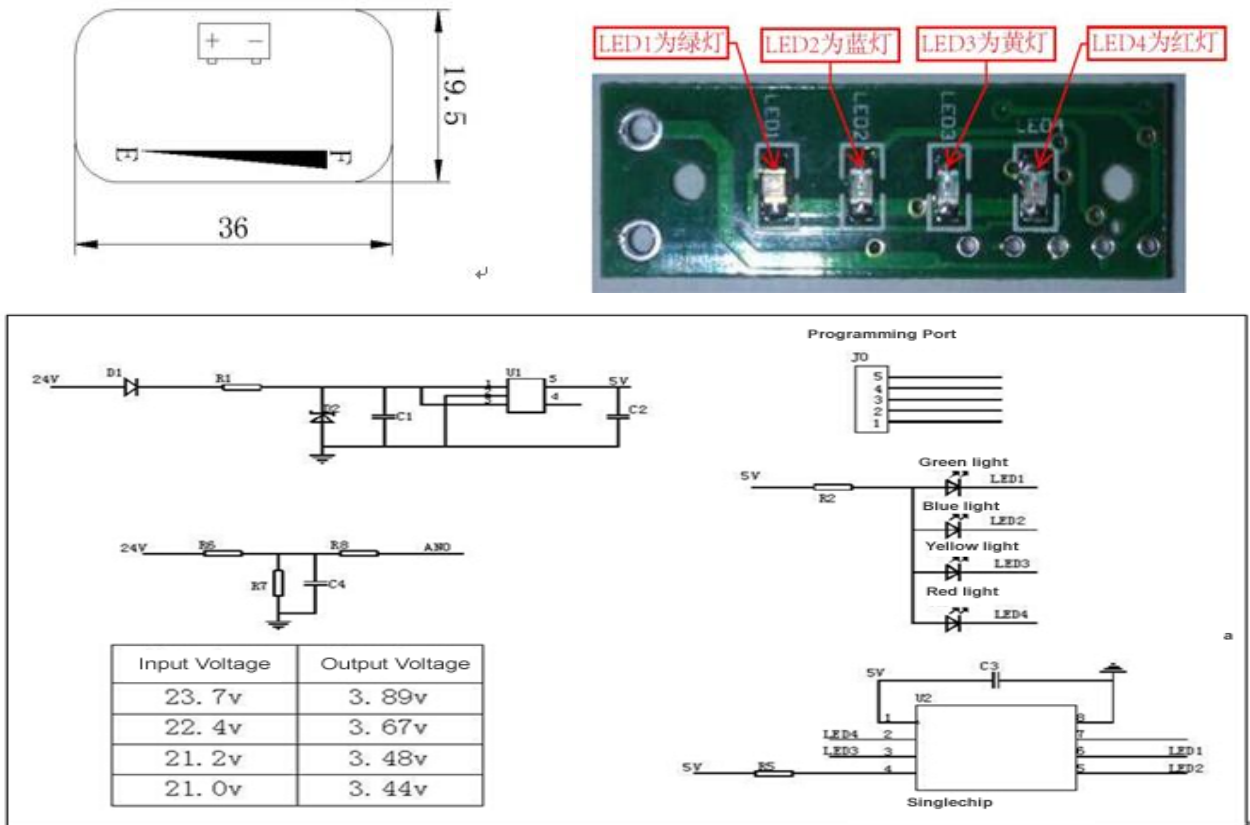

6.3. Charge

Optional automatic voltage charger can only be applicable to the mentioned 110V or 220V. Charging space must ensure good ventilation. After the completion of the charging of the battery, disconnect the connector from the socket, and put it in the specified storage location.

7. Regular Maintenance

Only qualified and trained personnel should inspect the maintenance of this truck.

Before maintenance, please always remover any products from the fork up and lower the forks to the lowest position.

For lifting procedures, review the specified instructions according to the fourth chapter lifting equipment. Before the operation, please safety secure movement of the truck (such as a specified jack, wedge or wood) under the truck to ensure security of movement.

Please pay attention to the maintenance of the handle bar. There is a gas spring has pressure.

Please use the original spare parts approved and issued by your dealer.

Please consider the leakage of the hydraulic fluid which may cause the machine breakdown and accident.

Only allow repair technician trained for pressure regulating valve.

If you need to replace the wheel, please follow the above instructions. Caster must be and no abnormal wear round.

Check and maintain the list of items on the list.

7.1. Maintain inventory

Table4: Maintain inventory		The interval of time			
		1	2	6	12
1	Check the hydraulic oil cylinder, for noise and leakage damage		●		
2	Check the hydraulic connections and tubing for damage and leakage		●		
3	Check the hydraulic oil level, then re-fill if necessary		●		
4	Fill the hydraulic oil (12 months or 1500 hours)				●
5	Check and adjust the pressure valve function (2205lbs+0/				●
Mechanical system					
6	Check the deformation and crack of fork		●		
7	Check the deformation and crack of the chassis		●		
8	Check all the screws are torqued completely		●		
9	Check the mast and the chain for corrosion, deformation	●			
10	Check for noise and leakage of gear box		●		
11	Check for wheel deformation or damage, replace if necessary		●		
12	Steering bearing lubrication				●
13	Check and lubrication center point		●		
14	Grease nozzle	●			
15	Protective and / or protection board, if damaged replace	●			
The electrical system					
16	Check for any wiring is damage				
16	Check if any wire is damaged		●		
17	Check the electrical connectors and connecting terminal		●		
18	Detection of the emergency stop switch function		●		
19	Check the electric drive motor noise and damage		●		
20	Detection display		●		
21	Check the use of the correct fuse, replace if necessary		●		
22	Test buzzer		●		
23	Check the current contactor		●		
24	Check for leakage of the frame (insulation test)		●		
25	Check the accelerator function and wear		●		
26	Check the drive motor of electric system		●		

	Brake system				
27	Check the brake performance, brake disc replacement or adjustment gap if necessary	•			
	Battery				
28	Check the battery voltage	•			
29	Clean and give the terminal grease, check whether there is corrosion and damage	•			
30	Check the battery shell is damaged	•			
	Charger				
31	Check the main power line for damages	•			
32	Start protection program check during charging	•			
	Function				
33	Test buzzer	•			
34	Air gap electromagnetic brake check	•			
35	Detection of the emergency brake function	•			
36	Detection of reverse braking and regenerative braking function	•			
37	Detection of belly switch function	•			
38	Check the steering function	•			
39	Check the lifting and lowering function	•			
40	Check the handle lever switch function	•			
41	Detection of the key switch is damaged and function	•			
42	The detection speed limit switch (lifting height is $> \sim 11.8\text{in}$)	•			
	Comprehensive				
43	Check all label is clear and complete	•			
44	Check protective plate and / or protection is not damaged	•			
45	Check the steering wheel, if worn for height adjustment or replacement		•		
46	A test run	•			

7.2. Lubrication points

Lubrication maintenance shown in listing marked points on the. Required grease specification: DIN51825, standard grease.

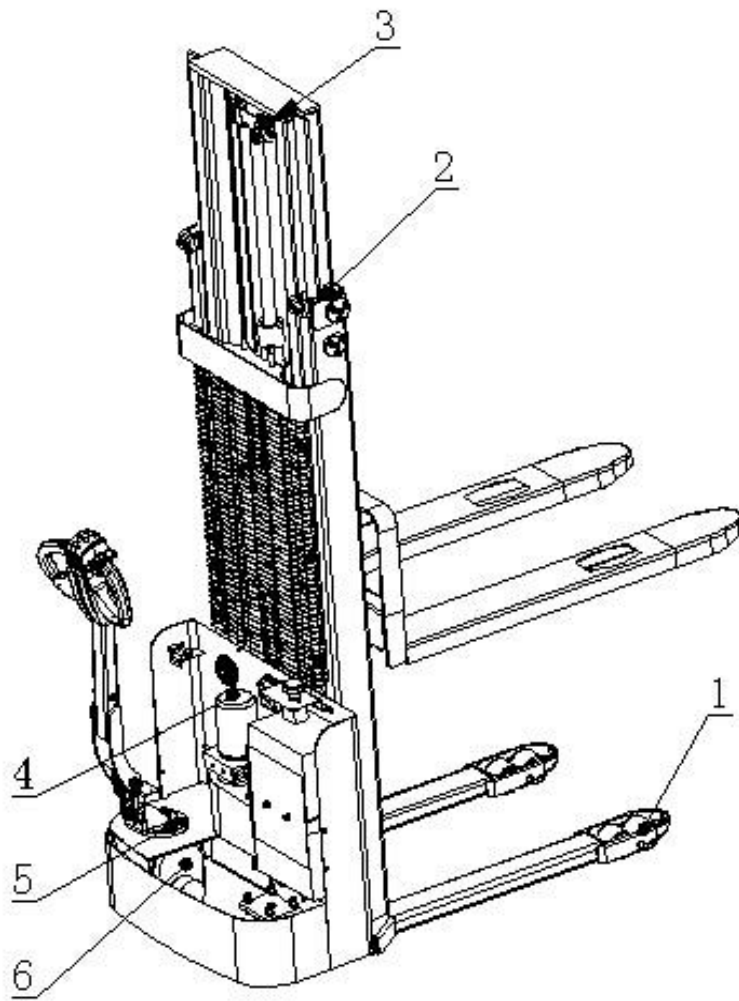

- 1. The wheel bearing
- 2. The door frame
- 3. Chain
- 4. Hydraulic system
- 5. Steering bearing
- 6. Gear box

7.3. Inspection and hydraulic oil refill needed hydraulic oil type

Anti-wear hydraulic oil 32#

Viscosity is 32 - 38

Based on the model, the amount of oil is from ~2.5L to 3.0L.

Waste materials such as waste oil, waste batteries or other materials must be recycled according to law.

7.4 Safety Screen

If you need to remove protective screen, unscrew the screw fixation and remove protective screen. Screw is still in the protective net. Re-installation, the protective plate placed in the correct position

and then tighten screws. If you need to change parts, please contact your nearest after sale service dealer.

8. Fault analysis

If the truck after to following the instructions of the chapter (6) is still at cause of functioning.

Table Failure analysis of 6:

Fault	Reason	Repair
The goods cannot ascend	Excessive weight	Decrease the maximum load
	Battery discharge	Charge the Battery
	Enhance the fuse failure	Check and the eventual
	The hydraulic oil level too low	Check and finally filled with
	The oil spills	Seal repair tubing and / or cylinder
Hydraulic Fluid	Oil is too high	Reduce oil
The goods cannot be dropped	Oil dirty blocking control valve	Check the hydraulic oil and valve.
	Declining electromagnetic valve does not open or damage	Check or replace down solenoid valve
Truck cannot operate	Check battery charge	Completely charge
	Battery is not connected	Check connections
	Fuse failure	Replace fuse
	Low battery	Charge Battery
	The emergency stop switch is activated	Pull the knob to eliminate the emergency stop switch Functioning
	The handle at the operation area	The handle is moved to the braking
Truck travels only in one direction	Accelerator and connectors do not function	Check the accelerator and connector to ensure proper contact
Stacker walking very slowly	Low battery	Check the discharge display battery
	Has launched the electromagnetic brake	Check the electromagnetic brake
	The handle is not connected or damage related wiring harness	Check the wiring harness and connector handle
Truck suddenly starts	The AC controller damages	Replace the controller
	The accelerator is not transferred back to the middle position	Repair or replace the accelerator