

EKKO[®]

MATERIAL HANDLING EQUIPMENT

MOVING AHEAD

LITHIUM WALKIE PALLET JACKS

EP18LI / EP20LI

- Lithium Powered
- 4000-4400 lbs. Capacity
- Forks 27x48"
- Internal Charger
- Compact & Economical
- Polyurethane Wheels
- Stability Casters
- Electromagnetic Braking
- Lithium Iron Phosphate
24V/40AH | 24V/60AH
- Batteries & Charger Included
- 3 Year Limited Warranty



EP18LI / EP20LI

Superior quality, maneuverable, compact, and durable for all your material handling applications. Ideal for small aisles and areas.

WEIGHT CAPACITY: 4000-4400 lbs.

LIFT HEIGHT: 7"

FORK LENGTH: 27x48"

TURNING RADIUS: 55"

BATTERY / CHARGER: LITHIUM IRON PHOSPH

ATE

Lithium24V/40-60Ah, Internal direct connect 110A

110VAC plug-in automatic 24V/15A charger (both Included)

SPEED TRAVEL: 3.3 mph empty ; 3.0 mph loaded

LIFTING SPEED: 1.1 ips empty; .8 ips loaded

LOWERING SPEED: 1.5 ips empty; 1.5 ips loaded

DRIVE WHEELS: 10.6" x 2.75" polyurethane

STABILITY CASTERS: 4" x 1.5" polyurethane

LOAD WHEELS: (2) 3.1" x 3.7" polyurethane

HYDRAULICS LIFTING MOTOR: 24V 800 Watt lifting motor with hardened chrome moly steel for durability.

DRIVE MOTOR: 24V 750-Watt drive motor for efficiency and high torque.

CONTROLLER: 24V provides performance through entire range of speed; Constant travel speed regardless of load; Battery discharge indicator combination gauge.

BRAKES: Electro-magnetic braking for secure stopping power; Electronic neutral braking for accurate control.

OPERATOR CONTROLS: Throttle, lifting, lowering, turtle mode and horn functions are in the ergonomic handle; turtle button; belly button reverse safety feature allows the unit to stop and reverse to avoid collision or injury.



LITHIUM PALLET JACKS

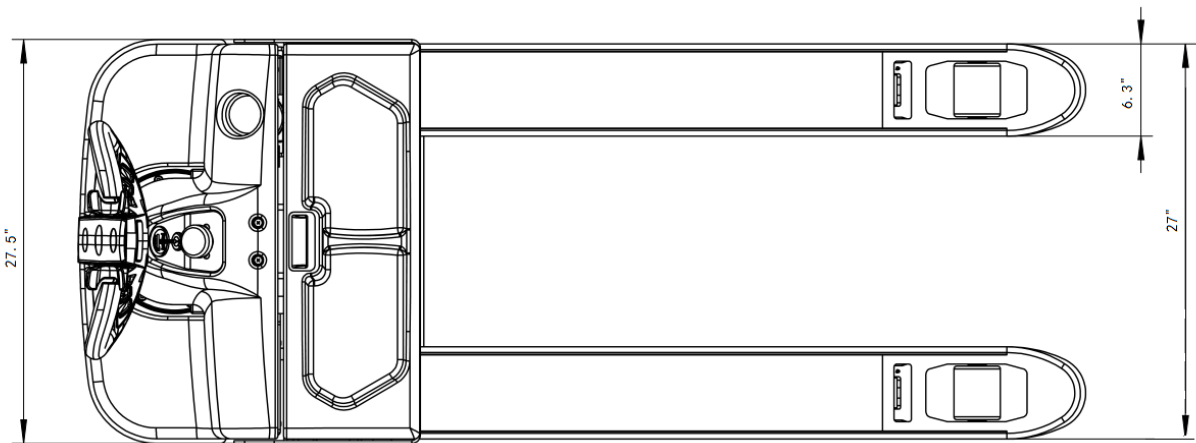
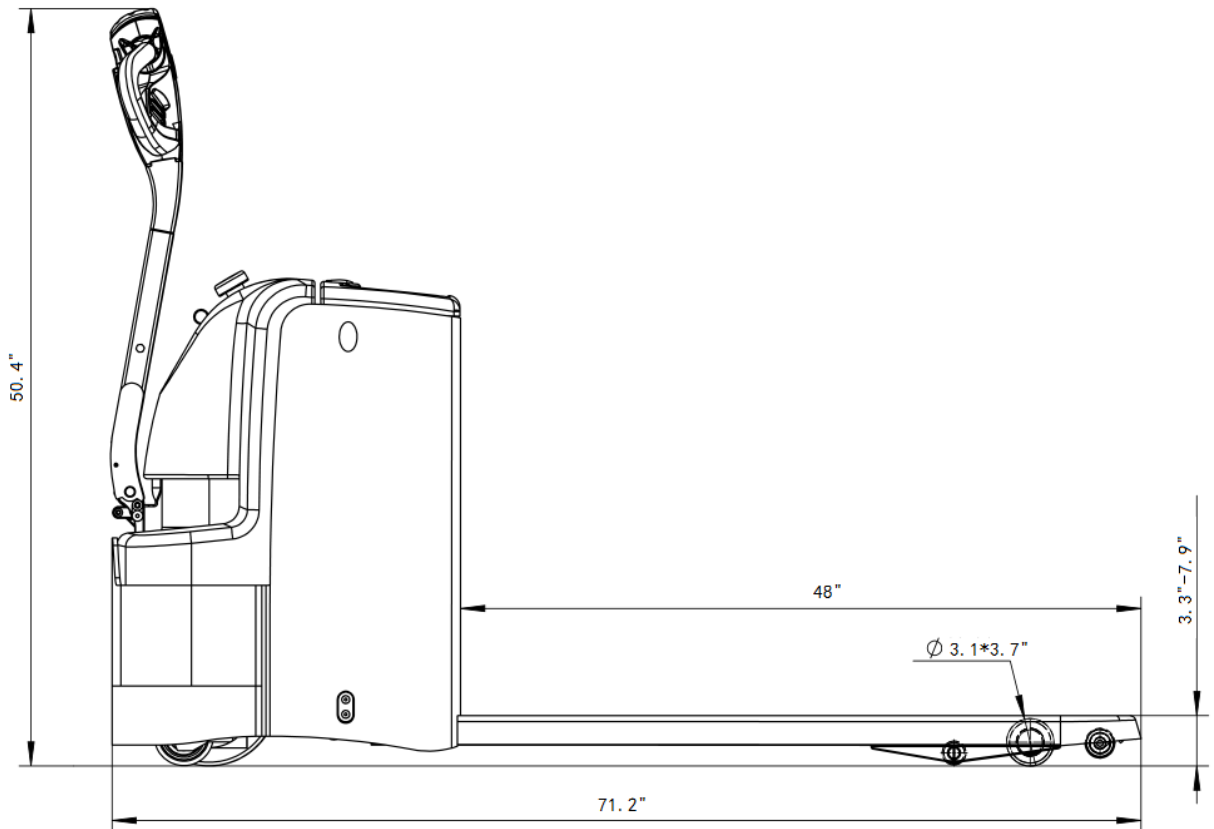

MODEL	LOAD CAPACITY	FORKS	LITHIUM BATTERY	SERVICE WEIGHT
EP18LI	4000lbs	27x48"	24V/40Ah	650 lbs.
EP20LI	4000lbs	27x48"	24V60Ah	680 lbs.



1761 W. Holt Ave.
Pomona, CA 91768 USA

T: (877) 232-6517 F: (909) 222-6861

AUTHORIZED DEALERS ONLY
www.ekkolifts.com