



EK14 SERIES
**EK14 / EK14-130 / EK14S-130 /
EK14-138 / EK14-130LI / EK14S-
189LI / EK14S-130LI**
**BALANCED LOAD STACKER
TRUCK**
INSTRUCTION MANUAL

**Welcome to use the pallet stacker
Hope our products can bring you greater convenience!**

- Please read the instructions carefully before you use the pallet stacker.
- This manual is a general manual and we reserve the right to make technical modifications to this product.If there are any differences between the manual and the actual product, please refer to the actual product, and the instructions are for reference only.

Warning

Vehicle operators must strictly implement ISO3691 "Motor Industrial Vehicle Safety Specifications", and untrained personnel are strictly prohibited to operate the vehicle.

According to ISO3691 "Safety Specification for Motor Industrial Vehicles", the load and lifting height of QPS15GCY type counterbalanced forklift truck produced by our company are as follows:

Its load capacity can be referred to the following figure, the following figure is the rated load of 1500Kg load curves.

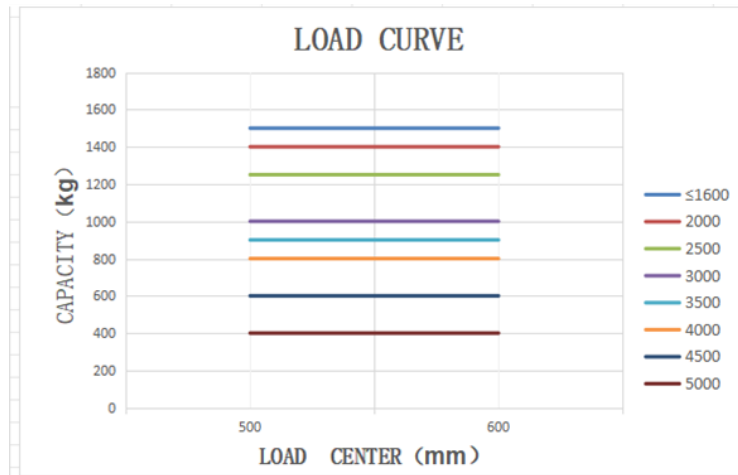

Please use strictly according to the load curve, do not overload

Attention:

When the lifting height of the fork exceeds 500mm, the stacker must drive in a straight line at the lowest speed. Shall not turn to drive and the continuous walking distance shall not exceed 2m.

Failure to comply with these rules can result in:
A Serious risk of injury to the driver or other person.
B Damage to vehicles and goods.

Foreword

Before operating this stacker, please read this manual carefully and fully understand how to use this stacker. Improper operation may cause danger. This manual describes the use and operation of different types of pallet stackers. When servicing the stacker, make sure it matches your model.

Please keep it for future use. If this manual or warning/warning label is damaged or missing, contact your local dealer for a replacement.

This stacker complies with EN 3691-1 (Industrial vehicles - Safety requirements and verification, Part 1), The standards of EN 12895 (Industrial vehicles - electromagnetic compatibility), EN 12053 (Safe industrial vehicles - test methods for the measurement of noise emissions), EN 1175 (Safety of industrial vehicles - electrical performance requirements) must ensure that the vehicle is used in accordance with the above purposes.

According to EN 12053, the noise level in the driver's ear is 69 dB(A).

According to EN 13059 (if the vehicle has pedals), the vibration is 0,85 m/s².

Attention:

- Hazardous waste that is harmful to the environment, such as waste batteries, waste oil and electronic products. If not properly disposed of, it will have a negative impact on the biological environment or human health.
- Waste packaging should be classified into solid waste bins according to the material, and collected by the local special environmental protection bureau. In order to avoid pollution, it is forbidden to throw litter at random.
- In order to avoid oil leakage when using the product, users should prepare some absorbable materials (waste wood chips or dry rags) to absorb the leaking oil in time. In order to avoid secondary pollution of the environment, used absorbable materials should be handed over to specialized departments in accordance with local authority regulations.
- Our products continue to improve, because this manual is only for the operation/maintenance of the stacker for the purpose, so this manual can not guarantee other special circumstances. Please understand.



Note: In this manual, the symbols on the left indicate warnings and dangerous conditions that could result in death or serious injury if not followed.

Copyright

Copyright is reserved by the company mentioned in the CE standard at the end of this document.

Contents

1. Proper use
2. Technical parameters
3. Functions and Application Scope
4. Structure Overview
5. Instructions for Use and Operation
6. Safety Devices and Safety Signs Explanation
7. Maintenance and Care
8. Common Faults and Their Solutions
9. Packaging and Transportation
10. Schematic Diagram

1. Proper use

This stacker is only allowed to be used in accordance with this instruction manual.

The stacker described in this manual is a self-propelled, walking pallet stacker with the function of electrically operated height control. This stacker is designed to lift, lower and transport rack loads.

Improper use can result in personal injury or machine damage. The operator/operating company shall ensure proper use and that the stacker is only operated by persons who have been trained and authorized to use the vehicle.

The stacker must be used on a solid foundation, flat, intact plane and suitable surface. The vehicle is designed for indoor use at room temperature from +5C to +40C and for light loads without crossing permanent obstacles or potholes. It is prohibited to operate on slopes. When operating, the goods must be placed approximately at the center of the load of the stacker.

Lifting or carrying of persons is strictly prohibited. If carried, the cargo must be lowered to the lift point.

It is prohibited to use this vehicle on the tailgate or on the loading ramp.

The load rating is indicated on the capacity label and nameplate, and the operator must pay attention to these warning signs and safety instructions. Operating illumination must be at least 50 lux.

Changes

Any alteration that may affect the load rating, stability or safe operation of the vehicle shall be subject to the prior written approval of the vehicle's manufacturer of origin or its authorized manufacturer or its replacement. This includes the effects of changes such as increased braking, steering, visibility and movable accessories. When modification or changes have been approved by the manufacturer or its replacement, nameplate capacity, labels, identification marks, operation and maintenance manuals will be changed accordingly.

Failure to follow these instructions to cause damage to the vehicle will result in loss of warranty.

2. Technical parameters

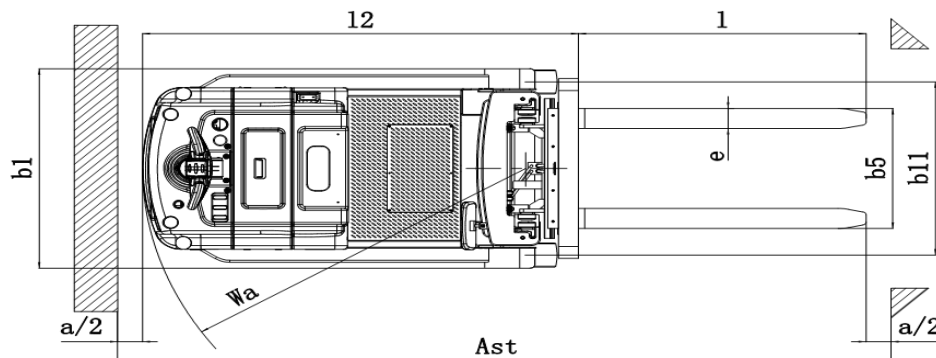
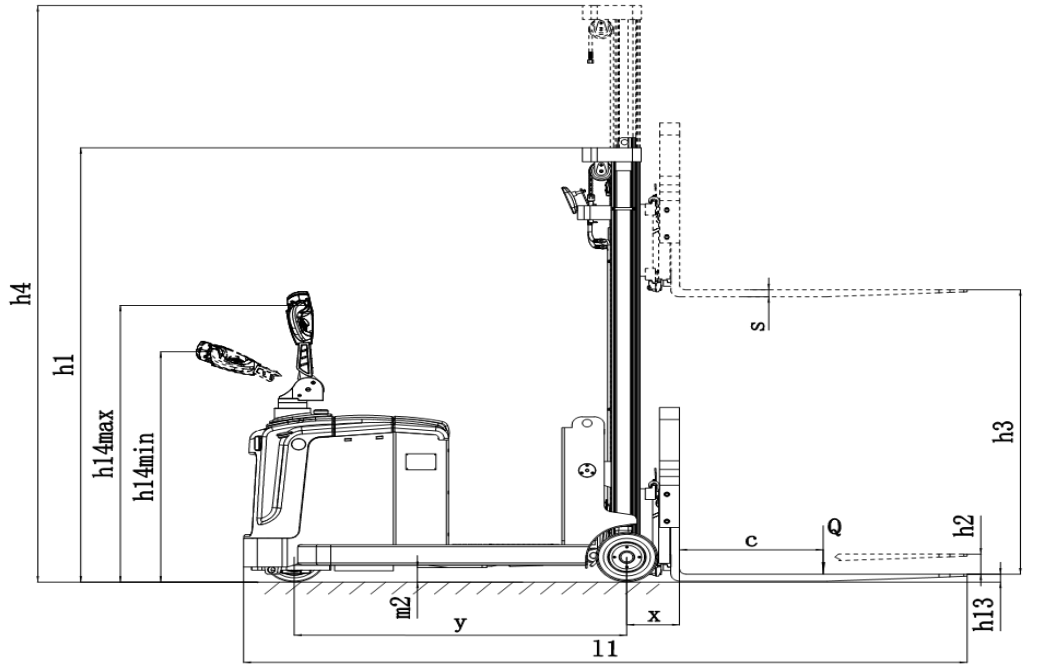

| EK14 Series - EK14 / EK14-130 / EK14S-130 / EK14-138 / EK14-130LI / EK14S-189LI / EK14S-130LI | | | | |
|---|------|--|-----------|------------------|
| Distinguishing mark | 1.2 | Manufacturer's type designation | | |
| | 1.3 | Power(battery,diesel,petrol gas>manual) | | Battery |
| | 1.4 | Operator type | | Pedestrian |
| | 1.5 | Load capacity/Rated load | Q(lbs) | 3,300 |
| | 1.6 | Load centre distance | C(in) | 23.6 |
| | 1.8 | Load distance,centre of drive axle to fork | x(in) | 8.3 8.9 |
| | 1.9 | Wheelbase | Y(in) | 52.4 |
| Weight | 2.1 | Service weight | Lbs. | \ |
| | 2.2 | Axle loading,laden front/rear | Lbs. | \ |
| | 2.3 | Axle loading,unladen front/rear | Lbs. | \ |
| Tires,chass | 3.1 | Tires | | PU |
| | 3.2 | Tire size,front | ΦxW (in) | Φ9.8x3.0 |
| | 3.3 | Tire size,rear | ΦxW (in) | Φ9.8x4.7 |
| | 3.4 | Additional wheels(dimensions) | ΦxW (in) | \ |
| | 3.5 | Wheels,number front/rear(x=driven wheels) | | 1x/2 |
| | 3.6 | Track,front | b10(in) | \ |
| | 3.7 | Track,rear | b11(in) | 34.1 |
| Dimensions | 4.4 | Lift height | h3(in) | 118-138 |
| | 4.19 | Overall length | l1(in) | 113.9 114.4 |
| | 4.20 | Length to face of forks | l2(in) | 68.7 69.2 |
| | 4.21 | Overall width | b1(in) | 39.3 |
| | 4.22 | Fork dimensions | s/e/l(in) | 1.2/3.9/45.3 |
| | 4.25 | Distance between fork-arms | b5(in) | 8.3/23.6 |
| | 4.32 | Ground clearance, centre of wheelbase | m2(in) | 2.9 |
| | 4.33 | Aisle width for pallets 1000X1200 crossways | Ast(in) | 107.3 106.8 |
| | 4.34 | Aisle width for pallets 800X1200 lengthways | Ast(in) | 110.3 109.7 |
| | 4.35 | Turning radius | Wa(in) | 60.4 |
| Performance | 5.1 | Travel speed,laden/unladen | Mph | 3.2/3.4 |
| | 5.2 | Lift speed,laden/unladen | in/s | 3.9/4.7 |
| | 5.3 | Lowering speed,laden/unladen | in/s | 5.1/4.7 |
| | 5.8 | Max.gradeability, laden/unladen | % | 6/8 |
| | 5.10 | Service brake | | Electromagnetic |
| Electric-engine | 6.1 | Drive motor rating S2 60min | Hp | 2.3 |
| | 6.2 | Lift motor rating at S3 10% | hp | 3.0 |
| | 6.3 | Battery, acc to DIN 43531/35/36 A,B,C, no | | \ |
| | 6.6 | Energy consumption acc. to VDI cycle | kWh/h | \ |
| Additional data | 8.1 | Type of drive control | | Ac speed control |
| | 8.4 | Sound level at driver's ear acc. to EN 12053 | dB(A) | 69 |

5. Instructions for use and operation

The walking and lifting of the all-electric pallet stacker are based on the battery as the power source to carry the goods and stack the goods in a short distance; The correct use and operation of the vehicle will bring great convenience to your work, and the incorrect operation and use of the vehicle will damage the vehicle or bring danger to your personal safety and cargo.

5.1 Before use:

5.1.1 Before use, please check whether the vehicle is normal: whether the hydraulic pipeline has oil leakage, whether the support wheel can work normally, there is an unimpeded death phenomenon, it is strictly prohibited to use the faulty vehicle.

5.1.2 Check whether the battery is powered, as shown in Figure 5-1, pull out the main power switch to turn on the main power, open the electric door lock on the handle, and check the energy meter on the vehicle instrument table. If the 0 end is bright, it indicates that the battery has no power at this time, and the battery should be charged. It is forbidden to use the vehicle without power. This will greatly reduce the service life of the battery, and even damage the battery.

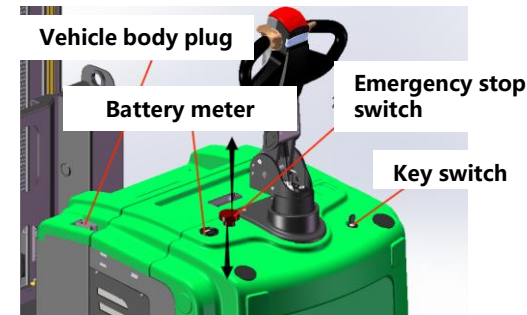

Figure 5-1



Figure 5-2

5.1.3 Check whether the vehicle brake is normal; Check whether the movements of the vehicle are normal, such as lifting, descending, and driving before and after; Check whether the emergency reverse action of the vehicle is normal. Figure 5-2 shows the method:

Turn the handle to area A or C, as shown in Figure 5-2, and press the up and down buttons on the handle to check whether the fork can be lifted or lifted normally. Then switch the operation handle to the B position as shown in Figure 5-2, slowly start the vehicle, and press the handle to the horizontal position to see whether the vehicle can run and brake normally;

Turn the handle to area B as shown in Figure 5-2, and press the emergency reverse switch on the top of the handle to see whether the vehicle can move forward. Through the above inspection, if the vehicle has no fault, the vehicle can be put into use, if there is a fault, please repair immediately, it is strictly prohibited to use the faulty vehicle.

| Characteristics | Reduce the height of the support frame h1(in) | Freedom to ascend to greater heights h2(in) | Improvement h3(in) | The extendable height of the gantry h4(in) | Lifting + lowest height of the fork lift h3+h13(in) |
|--------------------------------------|---|---|--------------------|--|---|
| EK13 | | | | | |
| Single gantry | — | — | — | — | — |
| Two gantries | 85.5 | — | 128.3 | 165.9 | 129.9 |
| Two gantries are fully free. | — | — | — | — | — |
| Three-column gantry | — | — | — | — | — |
| Three-column free-standing structure | 83.1 | 63.0 | 187.4 | 221.8 | 189.0 |

3. Purpose and scope of use

QPS15GCY type all-electric pallet stacker, is the use of battery as the power source, DC (AC) motor as the power, through the gear drive to drive the vehicle to walk, the lifting of the fork by DC motor and hydraulic transmission, to promote the oil cylinder up and down movement to lift the fork and goods. Since the walking and lifting of the stacker are electric, it has the characteristics of labor saving, high efficiency, smooth operation of the goods, simple operation, safe and reliable, low noise, no pollution and so on. The vehicle is suitable for cargo stacking and handling operations on hard, flat surfaces.

Use environment:

- The altitude does not exceed 1200m;
- Ambient air temperature shall not exceed +40°C, not lower than -25°C;
- When the ambient temperature is +40 °C, the relative humidity is not more than 50%, and at lower temperatures, a larger relative humidity is allowed;
- Hard, flat ground;
- It is prohibited to use the stacker in flammable and explosive or acid and alkali corrosive environment.

4. Structure introduction

The vehicle is mainly composed of frame, door frame, cargo fork, lifting cylinder, operating handle, steering gear, driving wheel, battery, hydraulic power unit, electrical control system and other components.

5.1.4 Operation Handle Button Instructions:

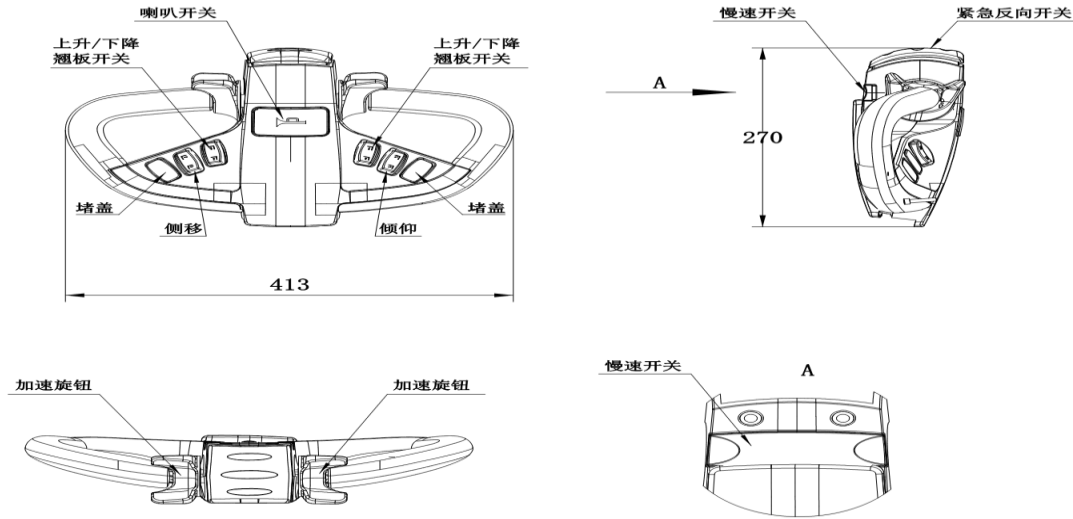

5.1.5 Lift and tilt demonstration of the gantry:

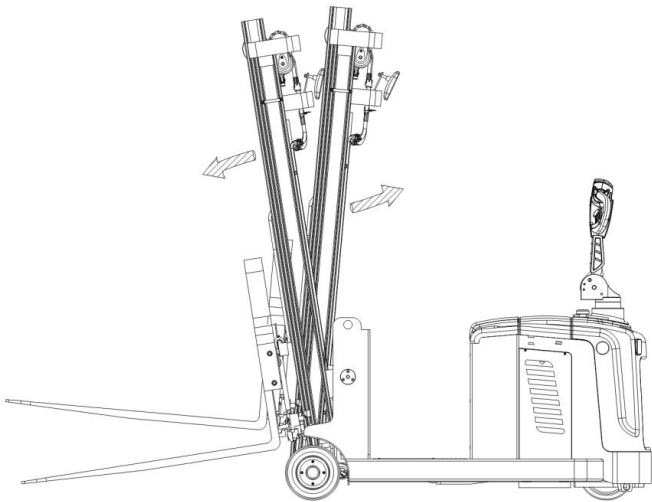

1. The tilt and elevation buttons on the handle can adjust the forward and backward tilt of the frame.
2. The function's purpose: To ensure the balance and stability of the goods during stacking and handling.

5.1.6 Demonstration of Fork Side Shift:

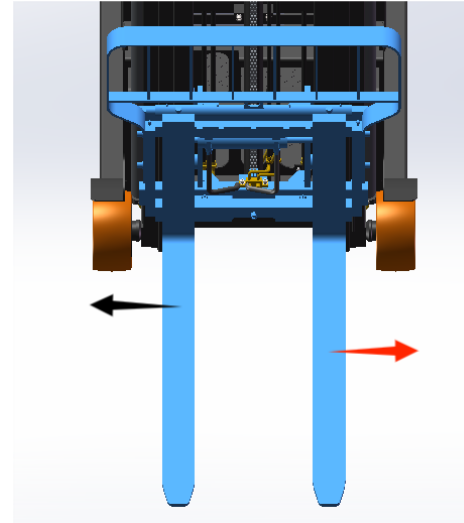

1. The side movement button on the handle can adjust the left-right movement of the fork frame.
2. The function's purpose: Facilitates the insertion and stacking of goods.

5.2 In Use:

5.2.1 Note: This vehicle is equipped with a back-magnetic brake at the end of the drive wheel motor, as shown in Figure 5-1. Pull out the main power switch to turn on the main power supply, unlock the power switch, and push the driving regulator. Only when the back-magnetic brake is powered on and opened can the stacker crane be powered on and operate. In other states, the stacker crane will be de-energized and braked. Ensure that the stacker crane is in a stationary state, the back-magnetic brake is in the locked state, and only then can the goods be lifted. During the lifting process, the vehicle cannot move. When transporting and stacking, ensure that the center of gravity of the goods is at the specified load center position, and the weight of the goods should be less than the weight indicated on the load curve. When stacking, only move forward and backward slowly, and do not perform turning operations.

5.2.2 Handling and stacking operations:

As shown in Figure 5-1, pull out the main power switch to turn on the main power supply, unlock the electrical door, drive the vehicle to the vicinity of the cargo pile (with the head of the fork 300mm away from the cargo pile), press the lowering button, adjust the fork height to an appropriate position, slowly and as deeply as possible insert the fork into the cargo pallet, press the raising button, until the fork is at a height of 200-300mm from the ground, drive the vehicle to the shelf position and slowly park it 300mm away from the fork head of the shelf, press the raising button, raise the fork to an appropriate height on the shelf (the bottom of the pallet is about 100mm higher than the shelf), slowly move the goods to the exact position on the shelf, press the lowering button, carefully place the goods on the shelf, and release the fork from the goods, slowly drive the vehicle, move the fork out of the cargo pallet (with the fork head 300mm away from the shelf), lower the fork to a height of about 100mm from the ground, and drive the vehicle away from the shelf. During the driving process, pay attention to whether there are obstacles in front, behind, left or right, and slow down when turning.

5.2.3 Operation of removing goods from the shelves:

As shown in Figure 5-1, pull out the main power switch outward, turn on the main power supply, unlock the power switch, drive the vehicle to a position near the shelves (with the head of the fork 300mm away from the shelves), press the up button, adjust the fork height to an appropriate position on the shelves, slowly insert the fork as deeply as possible into the goods pallet, press the up button, lift the goods to a height of 100mm from the bottom of the pallet and the shelves, slowly move the vehicle to slowly remove the goods from the shelves (with the head of the fork 300mm away from the shelves), press the down button, lower the fork to a height of 200-300mm from the ground, drive the vehicle away from the shelves, drive to the required position and slowly stop the vehicle, press the down button, lower the goods, use the fork to completely detach the goods, and slowly remove the fork from the goods pallet.

5.3 Handling of abnormal situations during use:

When the upward button is pressed, the fork can rise. However, when the upward button is released, the fork continues to rise and is in an out-of-control upward state. At this time, the power main switch should be immediately turned off to cut off the power. Move the vehicle to a safe position and lower the goods manually. Inspect the vehicle's circuitry.

During use, if you find that the braking fails, you must immediately stop using the vehicle and conduct an inspection.

When the vehicle is reversing and the operator is pushed against a wall or other object, as long as the emergency reverse switch button at the top of the operation handle is pressed, the vehicle will automatically reverse forward instead of causing harm to the operator.

5.4 After Use:

After use, park the vehicle at a fixed parking location and perform daily maintenance as stipulated in Article 7. Also, charge the vehicle.

6. Safety Devices and Safety Signs Explanation

6.1 Vehicle Height Limitation Explanation: As shown in Figure 6-1

On the gantry, the height of the pallet frame is limited through micro-switches or mechanical limiters to prevent the pallet frame from exceeding the maximum height.

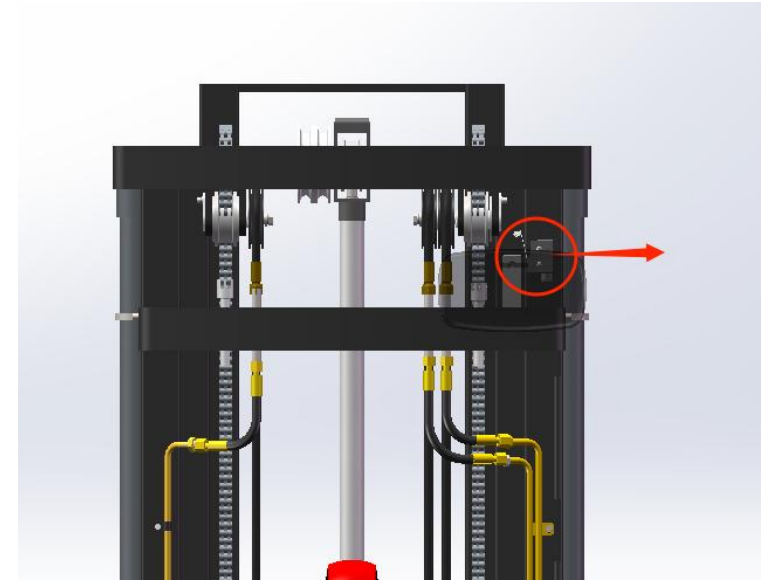

6.2 Vehicle lifting speed limit explanation: When the vehicle passes through the sensor switch and the pallet frame is raised to 400mm, the vehicle's speed will be limited.

7、Maintenance

Note: Untrained personnel are not allowed to repair the vehicle

7.1 The satisfactory use of the vehicle depends on careful maintenance, neglect of which may endanger personal safety, damage the vehicle and property. Therefore, when in use, regular inspections should be carried out regularly to eliminate abnormal phenomena in time, and do not use faulty cars to ensure safety and extend the service life of the vehicle.

7.2 Maintenance: The maintenance of the vehicle is generally divided into three levels, that is, daily maintenance, first-class maintenance, second-class maintenance.

Daily maintenance: should be carried out once a day, the main content is to keep the body surface clean, clean the battery surface, check whether the power cord is firm, the chain tightness is normal.

First-class maintenance: Maintenance once a week, in addition to daily maintenance content, should focus on checking whether the work of each component is normal, whether the fasteners are loose, whether the chain tightness is appropriate, whether the chain joint connection pin is bent and twisted, whether the inner and outer door frame up and down movement is normal, whether the hydraulic joint oil leakage, whether the mechanical part has abnormal wear, Whether the electrical part has abnormal temperature rise and spark, if found abnormal phenomenon should be adjusted and removed in time.

Second-class maintenance: should be carried out on schedule, and according to the following requirements for a comprehensive inspection of the vehicle.

a. Mechanical maintenance: once every six months, the main content is to lubricating the transmission gear and bearing of the drive wheel, adding lubricating oil to the rotating joints, and checking whether the fasteners are tight, whether the wheels are flexible, and whether the fork lift is normal. Clean up the dirt and dust accumulated on the friction plate of the electromagnetic brake, and adjust the gap between the friction plates to the appropriate distance. The vehicle running noise after maintenance is not more than 70 decibels.

b. Hydraulic maintenance: every 12 months, check whether the cylinder is in normal condition, whether there is internal leakage and external leakage, hydraulic joints, hydraulic hose is reliable without leakage phenomenon. Whether the hydraulic oil is clean, usually replace the hydraulic oil once every 12 months. Hydraulic oil adopts ISO oil standard. When the ambient temperature is -5 ~ 40°C, HL-N46 or HL-N68 is used, and when the ambient temperature is -35 ~ -5°C, HV-N46 or HV-N68 low-temperature hydraulic oil is used. The replaced waste oil shall be disposed of according to the relevant local regulations.

6.4 Instructions of safety labels:



Rain and moisture proof sign



Hoisting hook position sign



Watch out for the pinch sign



Safety warning sign

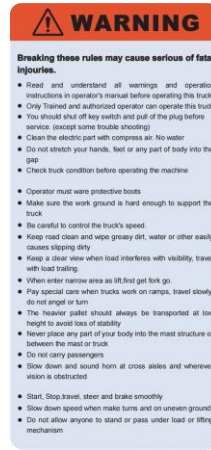

C. Electrical maintenance: every three months, the first is to check whether the specific gravity of the battery electrolyte is appropriate [tropical areas: use the specific gravity of 1.24 (25 ° c), other areas: If the specific gravity is 1.26 (25°C)], whether the battery terminal is clean, otherwise the specific gravity of the electrolyte must be adjusted according to the regulations, clean the terminal, and apply a little Vaseline, and correctly tighten. Then check whether the electrical connector is reliable, whether the switch is normal, and check whether the electrical insulation is normal (the insulation resistance of the electrical part and the vehicle body should be greater than 0.5MΩ). Remove the dirt, ash, carbon deposits of the motor, check the brush wear, and replace the brush as appropriate.

7.3 Adjustment of brake clearance:

- ① hollow screw ② connecting screw ③ spring ④ armature ⑤ motor shaft ⑥ spline sleeve ⑦ friction plate ⑧ electromagnetic coil ⑨ installation cover ⑩ installation screw

The structure of the brake is shown in the figure. After the vehicle is used for a period of time, the braking performance of the brake will decrease with the wear of the brake disc, or the brake disc cannot be released when it is locked, so the brake gap needs to be adjusted. As shown in the figure, in the braking state, first check the gap between the brake disc and the magnetic steel with a gauge, if the gap is greater than 0.5mm, it is necessary to adjust the gap, and the dirt and dust on the friction disc should be cleaned before adjustment. When adjusting, first loosen the connecting screw ②, then adjust the length of the adjusting screw ①, and then tighten the fastening screw, after adjustment, the gap between the brake disc and the magnetic steel should be between 0.2-0.3mm. When adjusting, pay attention to the balanced adjustment of the three adjusting screws, so that the gap between the brake disc and the magnetic steel is uniform around the adjustment. After adjustment, switch on the brake with 24V DC power supply, you should be able to hear the crisp sound of the brake.

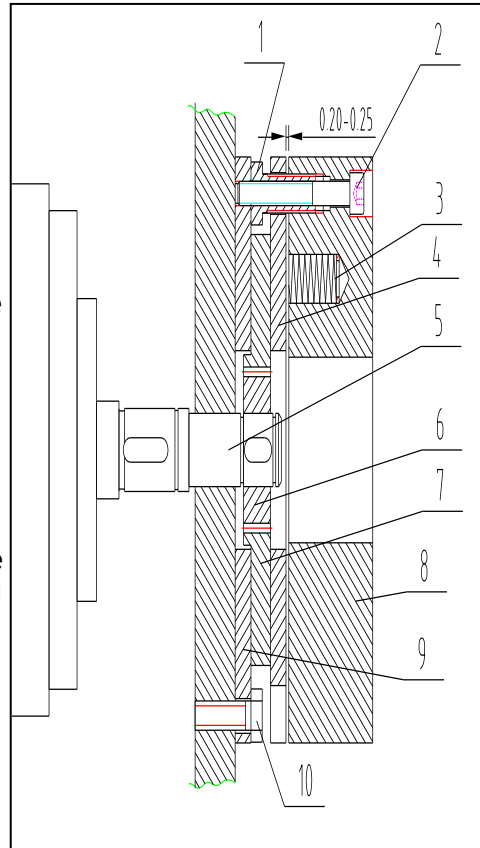

8. Common faults and troubleshooting methods

| Serial number | Breakdown | Reasons | Solutions |
|---------------|--|--|--|
| 1 | The stacker will not start (the contactor will not work) | ① The fuse of the control circuit has burned out | Replace |
| | | ② The power switch is in poor contact or damaged | Repair or replace |
| | | ③ The fuse of the main circuit has blown | Replace |
| | | ④ The electric lock switch is in poor contact or damaged | Repair or replace |
| | | ⑤ The battery connection is loose or disconnected | Screw down |
| | The stacker won't move (Contactor operation) | ① The magnetic brake on the driving wheel does not close, and the vehicle is in the braking state | Repair or replace |
| | | ② The carbon brush of the traveling motor is worn or the commutator is in poor contact with the carbon brush | Repair or replace |
| | | ③ The excitation coil of the traveling motor is broken or the wire end is in poor contact | Repair or replace |
| | | ④ The contactor contact is not in good contact | Repair or replace |
| | | ⑤ The MOSFET tube circuit board is faulty | Repair or replace |
| 2 | Stackers can only go forward (or backward) | ① The contactor is in poor contact or burned out ② Circuit board fault | Repair or replace Repair or replace |
| 3 | The stacker cannot stop while driving | The contactor contact is damaged and the moving contact is out of position | Cut off the power supply and replace the contactor contact |
| 4 | Brake failure | ① The mounting bolt of the microswitch is loose or damaged | Adjust or tighten the bolts, or replace the microswitch |
| | | ② The parmagnetic brake cable is loose or the parmagnetic brake is damaged | Tighten the bolt or repair the parmagnetic brake |
| | | ③ The para-magnetic brake disc is worn | Replacement disc |
| 5 | Steering jam | ① Steering gear bearing damaged | Change bearing |
| | | ② Steering gear bearing lack of oil or excessive sticky dust | Bearing cleaning |
| 6 | The driving wheel steering is heavy, there is noise, and the motor is in an overload state | ① Gear and bearing are stuck | Clean or replace bearings |
| | | ② Bearing installation gap, or ring off | Ring off, reinstall, adjust the gap |
| | | ③ Front wheel bearing damaged | Change bearing |
| 7 | The fork does not rise | ① Overloading | Load reduction |
| | | ② The relief valve pressure is too low | Turn up |
| | | ③ The lifting cylinder has abnormal internal leakage | Replace seal |
| | | ④ Lack of hydraulic oil | Add appropriate amount of filtered hydraulic oil |
| | | ⑤ The battery voltage is insufficient | Battery charging |
| | | ⑥ The control handle is not in the horizontal or vertical position, and the oil pump motor is not energized | Improper operation |
| | | ⑦ Oil pump motor damaged | Repair or replace |
| | | ⑧ Oil pump damage | Repair or replace |
| | | ⑨ The lift key switch is damaged | Repair or replace |
| | | ⑩ Electric lock not opened or damaged | Repair or replace |
| | | ⑪ The battery voltage is seriously insufficient | Charging |
| 8 | The fork does not fall after it rises | ① The inner frame is overloaded and deformed | Repair or replace |
| | | ② The outer frame is overloaded and deformed | Repair or replace |
| | | ③ Door frame roller stuck | Repair or adjust |
| | | ④ Frame guide rod bent | Repair or straighten |
| | | ⑤ The oil return hole is blocked | Clean |
| | | ⑥ Hydraulic station solenoid valve out of control | Troubleshoot the solenoid valve |
| 9 | Battery terminal voltage reduction (after charging) | ① A single battery is damaged | Repair or replace |
| | | ② Battery fluid level is low | Add electrolyte |
| | | ③ There are impurities in the electrolyte | Electrolyte change |

9.Packaging and transportation

This vehicle is packed in a tray. During transportation, it is not allowed to be overturned or inverted. When hoisting and loading onto the vehicle, it is not allowed to collide. When unpacking, the exterior of the vehicle should not be damaged.

10.Schematic diagram

1.Hydraulic schematic diagram

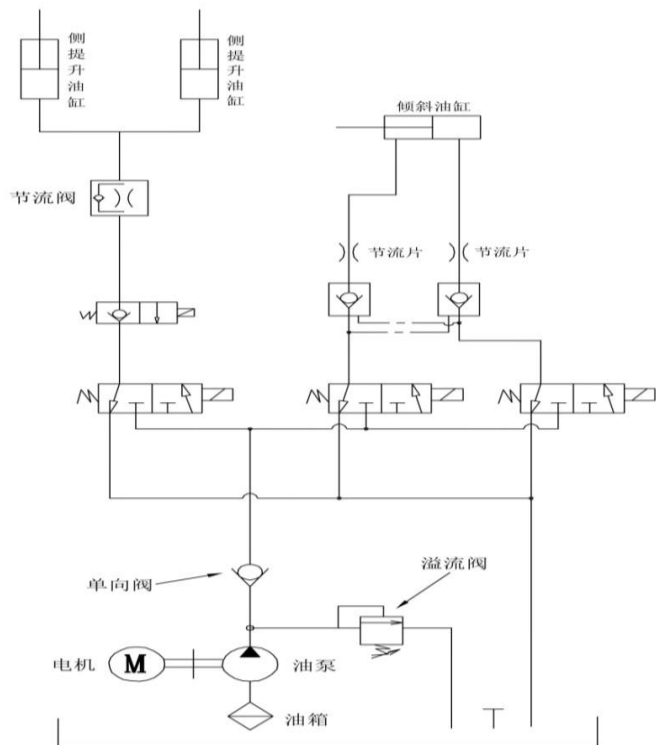

2.Electrical schematic diagram

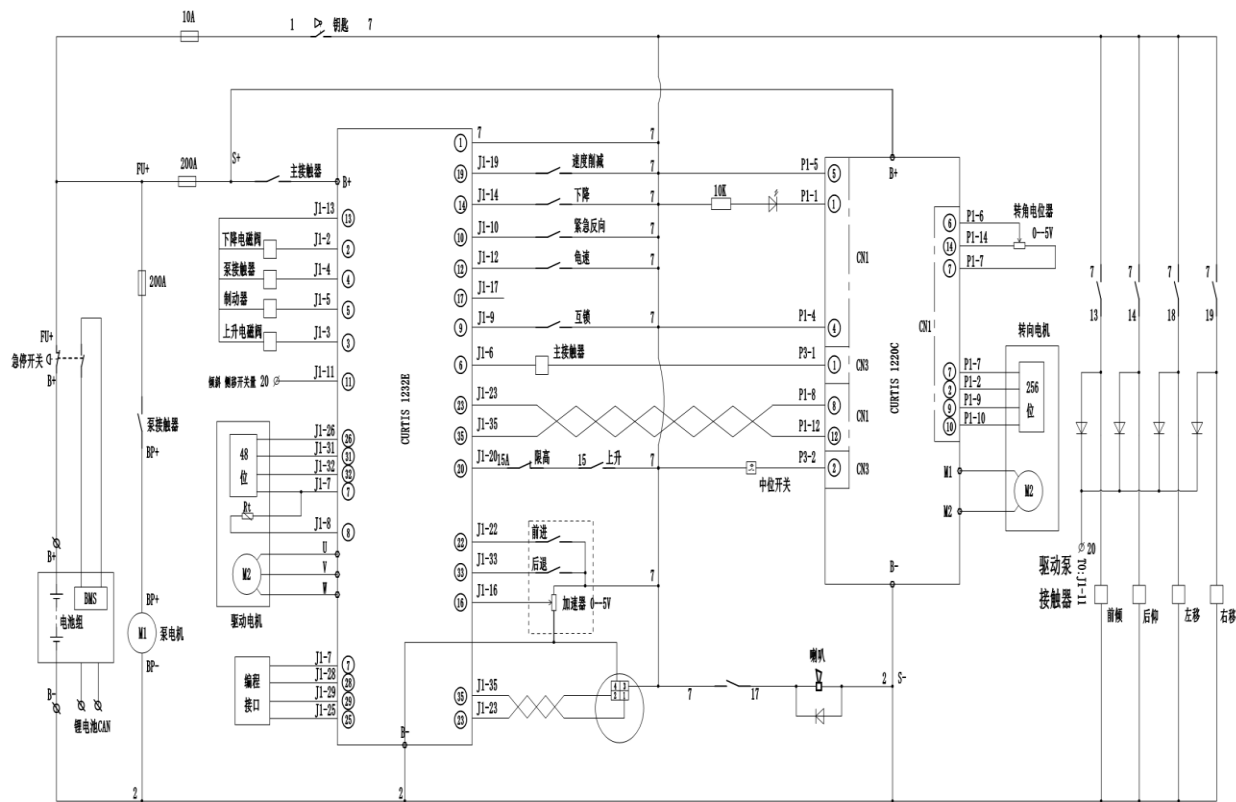

3.Brake schematic diagram

