

EKKO

MATERIAL HANDLING EQUIPMENT

MOVING **AHEAD**

LITHIUM WALKIE RIDER PALLET JACK

EP30A-Li

- 6600 lbs. Capacity
- Forks 27x48
- German AC Drive Motor
- Curtis Instrument Controller
- Stability Casters
- Electromagnetic Braking
- Lithium Battery Included
- Charger Included
- 3 Year Limited Warranty



EP30A-Li

Superior quality, maneuverable, compact, and durable for all your material handling applications.

WEIGHT CAPACITY: 6600 lbs.

LIFT HEIGHT: 9.17"

FORK LENGTH: 27x48"

TURNING RADIUS: 81.34"

BATTERY / CHARGER: 24V/150Ah Lithium Battery, direct connect 110A 110VAC plug-in automatic 24V/50A charger (both Included)

SPEED TRAVEL: 4.97 mph empty; 4.66 mph loaded

LIFTING SPEED: 1.1 ips empty; .8 ips loaded

LOWERING SPEED: 1.5 ips empty; 1.5 ips loaded

DRIVE WHEELS: 9.84" x 2.95" polyurethane

LOAD WHEELS: 4.88 x 2.36" polyurethane

HYDRAULICS LIFTING MOTOR: 24V 2200 Watt lifting motor with hardened chrome moly steel for durability.

DRIVE MOTOR: 24V 3000-Watt drive motor for efficiency and high torque.

CONTROLLER: 24V provides performance through entire range of speed; Constant travel speed regardless of load; Battery discharge indicator combination gauge.

BRAKES: Electro-magnetic braking for secure stopping power; Electronic neutral braking for accurate control.

OPERATOR CONTROLS: Throttle, lifting, lowering, turtle mode and horn functions are in the ergonomic handle; turtle button; belly button reverse safety feature allows the unit to stop and reverse to avoid collision or injury.

CHASSIS AND MAST: Robotic Welding; Heavy duty steel for durability.



LITHIUM WALKIE RIDER PALLET JACK

EKKO®

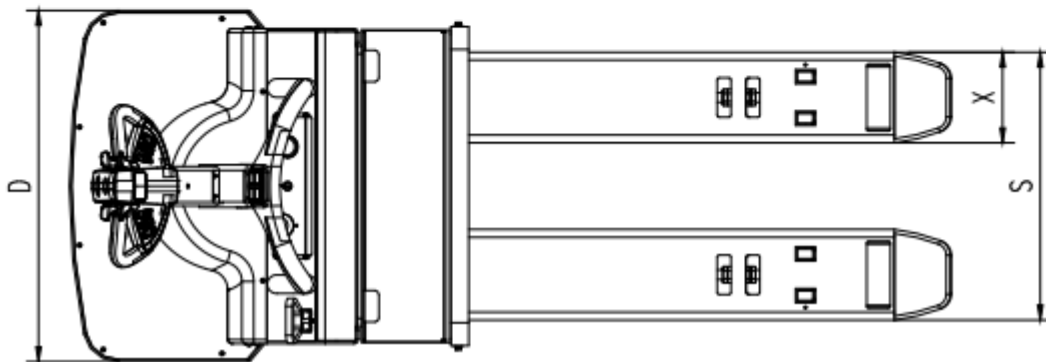
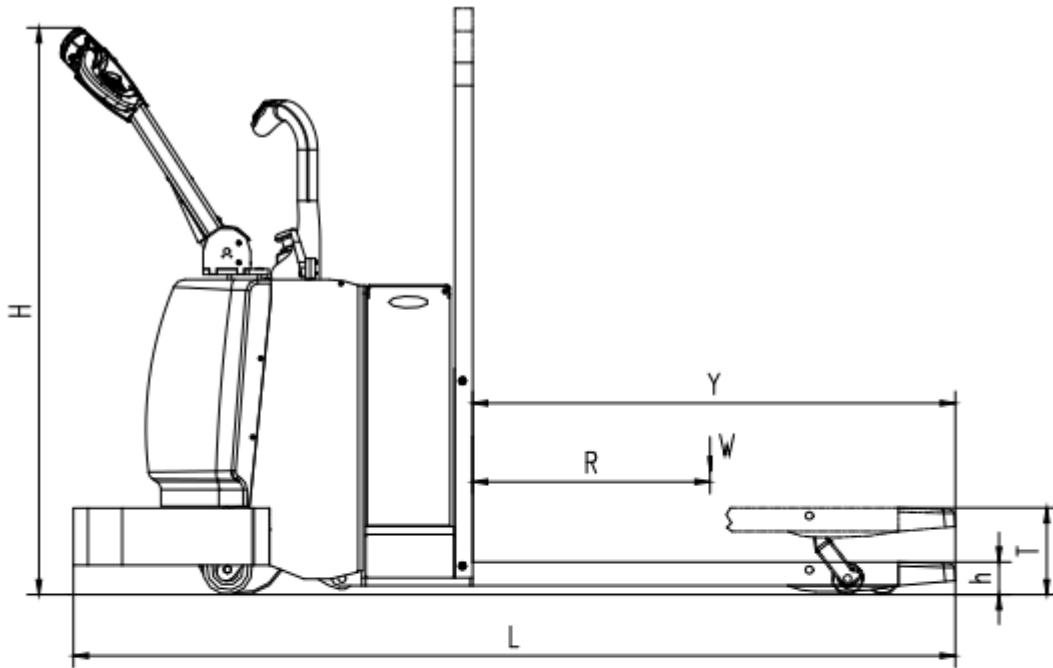

MODEL #	LOAD CAPACITY	LITHIUM BATTERY	SERVICE WEIGHT
EP30A-LI	6600LBS	24V/150Ah	1507LBS

EKKO
MATERIAL HANDLING EQUIPMENT
MOVING AHEAD

1761 W. Holt Ave. Pomona, CA
91768 USA T: (877) 232-6517 F:
(909) 222-6861

AUTHORIZED DEALERS
ONLY www.ekkolifts.com