



Operational & Maintenance Manual

Electric Stacker - EB13C Series
118/138/98LI/118LI/138LI/145LI



Instructions for use

Please read this manual carefully and operate the vehicle safety.

- Do not operate this vehicle without training.
- Please comply with ISO3691 “Safety Specification for Motor Vehicles Industry”.
- Please do not modify or change the repair parameters, including adjusting the pressure. Any loss or damage to the vehicle resulting from such actions will be your responsibility, and doing so will void our warranty commitment.

SPECIAL WARNING:

The company is committed to innovation and sustainable development. As part of this commitment, we continually improve the technology of our products. Therefore, we reserve the right to make changes and improvements to any product described in this specification without prior notice.

01. Main technical parameters

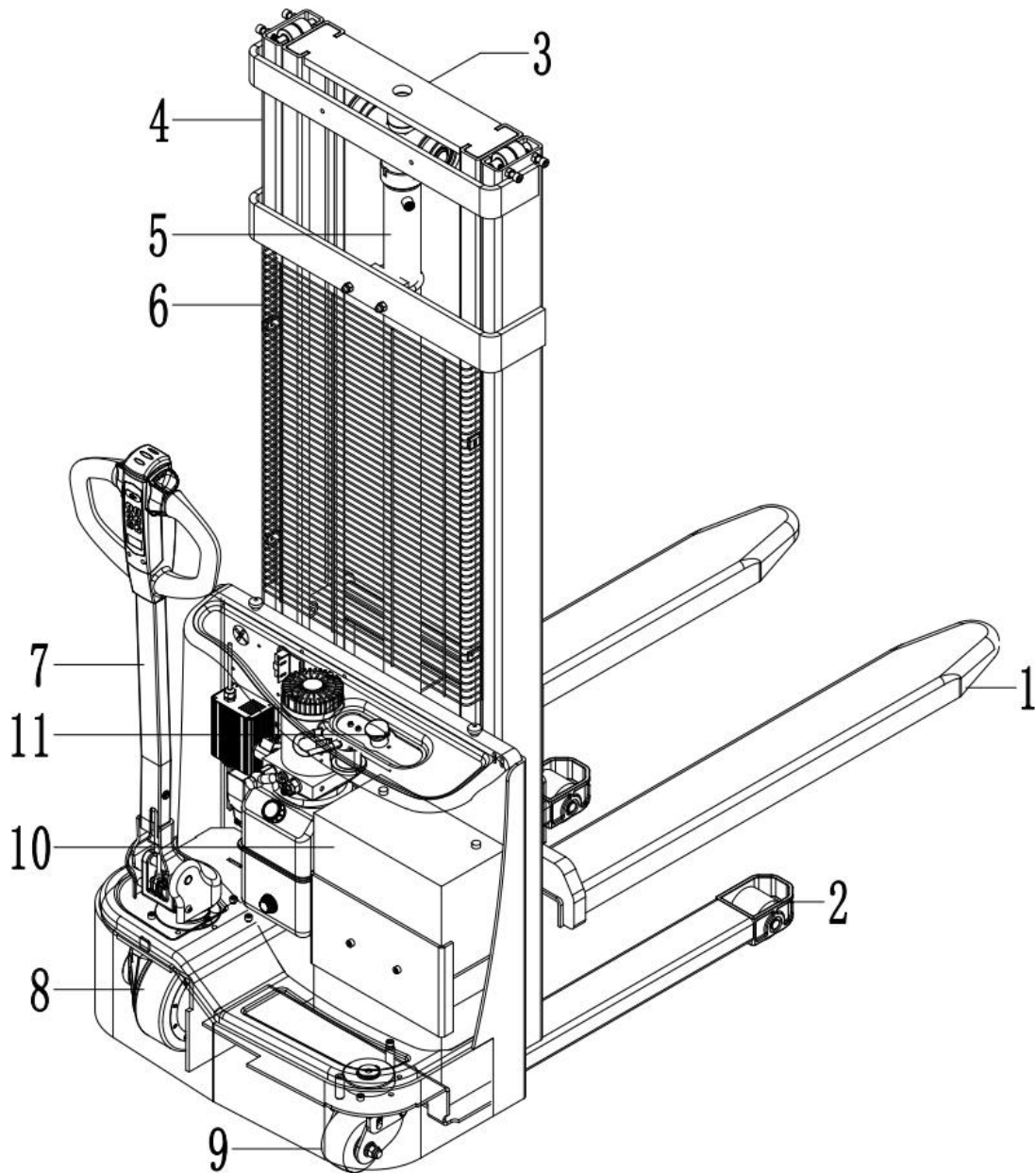

Item no.	Description	Item no.	Description
1	Fork	7	Handle
2	Loading wheel	8	Drive wheel
3	Inner mast	9	Balance wheel
4	Outer mast	10	Battery
5	Oil pump	11	Emergency button
6	Mesh guard		

02. Main technical parameters

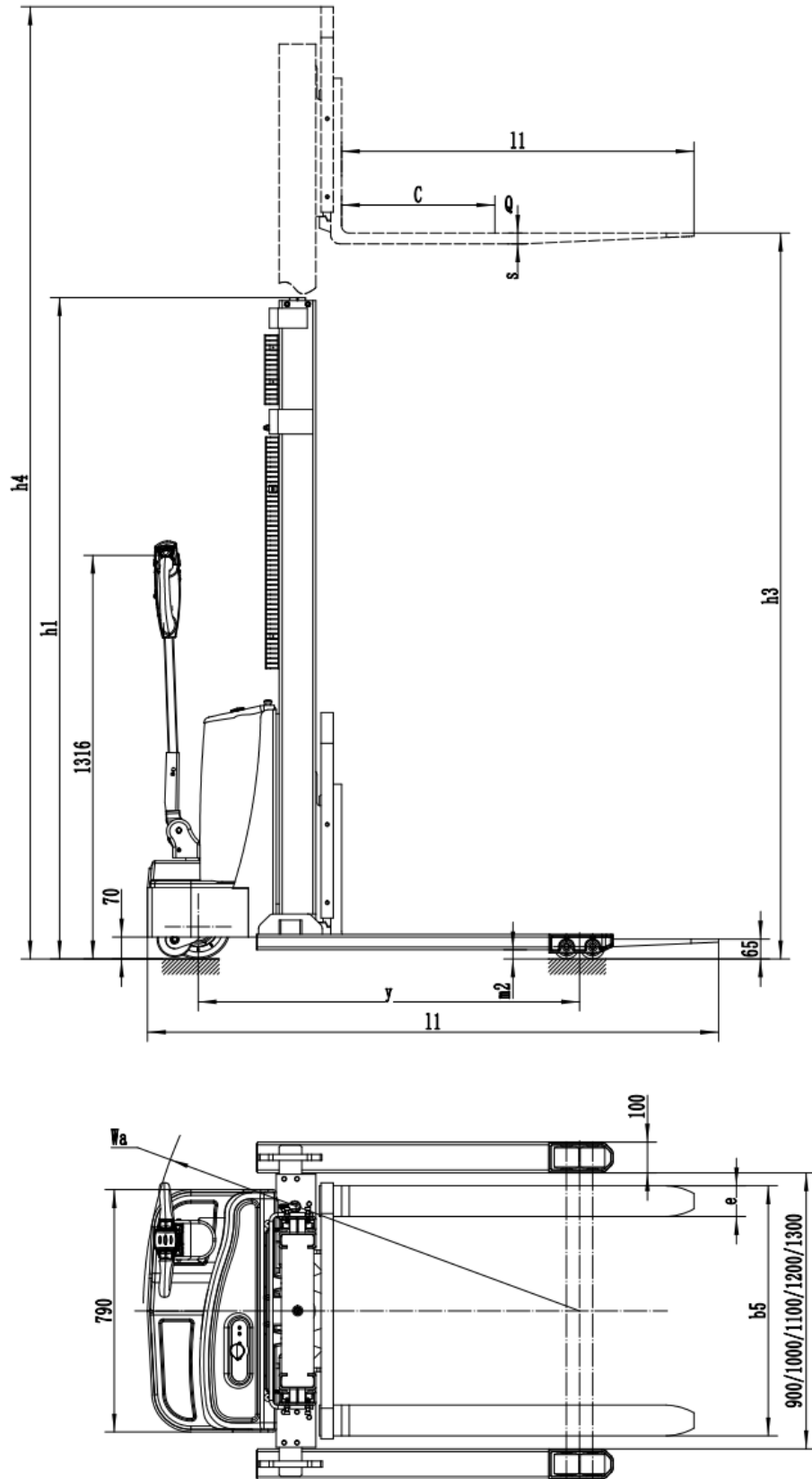

Trait	1.1	Model number		EB13CD / EB13C-98LI / EB13C-118 / EB13C-138
	1.2	Driving mode		Electric (battery)
	1.3	Driving mode		WALKIE
	1.4	Rated load	Q(lbs.)	2,800
	1.5	Load center distance	c(in)	20
Wheel	3.1	Wheel material		PU
Dimension	4.1	Lifting height	h3(in)	98/118/138
	4.2	Height when mast is lowered	h1(in)	75.2/85/94.8
	4.3	Maximum stacker height during operation	h4(in)	127.6/147.2/167
	4.2	Lower hour height	h13(in)	2.55
	4.3	Total length	l1(in)	73.42
	4.4	Legs wide inside	in	35.4/39.4/43.3/47.2/51.2
	4.5	Fork size	S/e/l(in)	1.38×3.94×45.28
	4.6	The fork is wide outside	b5(in)	8.66~32.09
	4.7	Minimum ground clearance	m2(in)	1.18
	4.8	Turning radius	Wa(in)	56.1
Performance data	5.1	Travel speed, full/empty	Mph	2.30/2.36
	5.2	Lift speed, full load/no load	in/s	3.54/5.12
	5.4	Gradeability	%	3/10
	5.5	Service brake	motor	Electromagnetic - regenerative braking
Electric machine	6.1	Drive motor power	kW	0.75
	6.2	Boost motor power	kW	2.2
	6.3	Battery voltage/rated capacity	V/Ah	Lithium battery 24/50 Lead-acid battery 24V/85
	6.4	Battery weight	Lbs.	50.7×2
Other	7.1	The noise level at driver's ear meets DIN12053	dB(A)	<70

03. Proper use and operation of your stacker

Correct use and operation of your stacker can significantly improve work efficiency. However, incorrect use can lead to damage to the equipment or personal injury.

Before using the stacker, please inspect the following:

1. Hydraulic Pipeline: Check for oil leaks.
2. Wheels: Ensure all wheels are intact and function properly.
3. Movement: Verify that there are no signs of jamming or sticking.

It is crucial to avoid using a faulty stacker.

Throttle Control

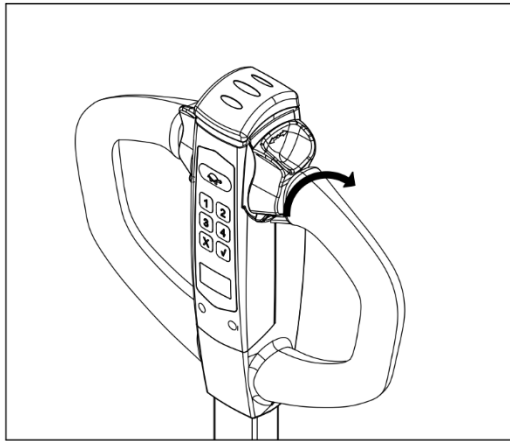

Rotate forwards

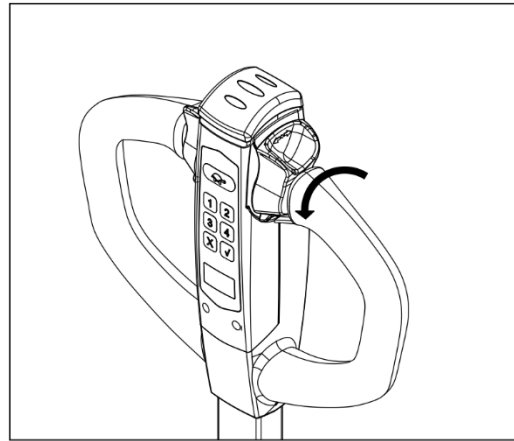

Rotate backwards

Forward and Reverse Driving

The flower-shaped turning button, located above and to the left of the rudder handle, controls the stacker's speed. You can operate this button with your left hand, right hand, or both hands.

To move the stacker forward:

1. Push the speed button forward.
2. The stacker will move forward at a speed proportional to the angle of the button.
3. Release the button to bring the stacker to a gentle stop.

To move the stacker backward:

1. Push the speed button backward.
2. The stacker will move backward at a speed proportional to the angle of the button.
3. Release the button to bring the stacker to a gentle stop.

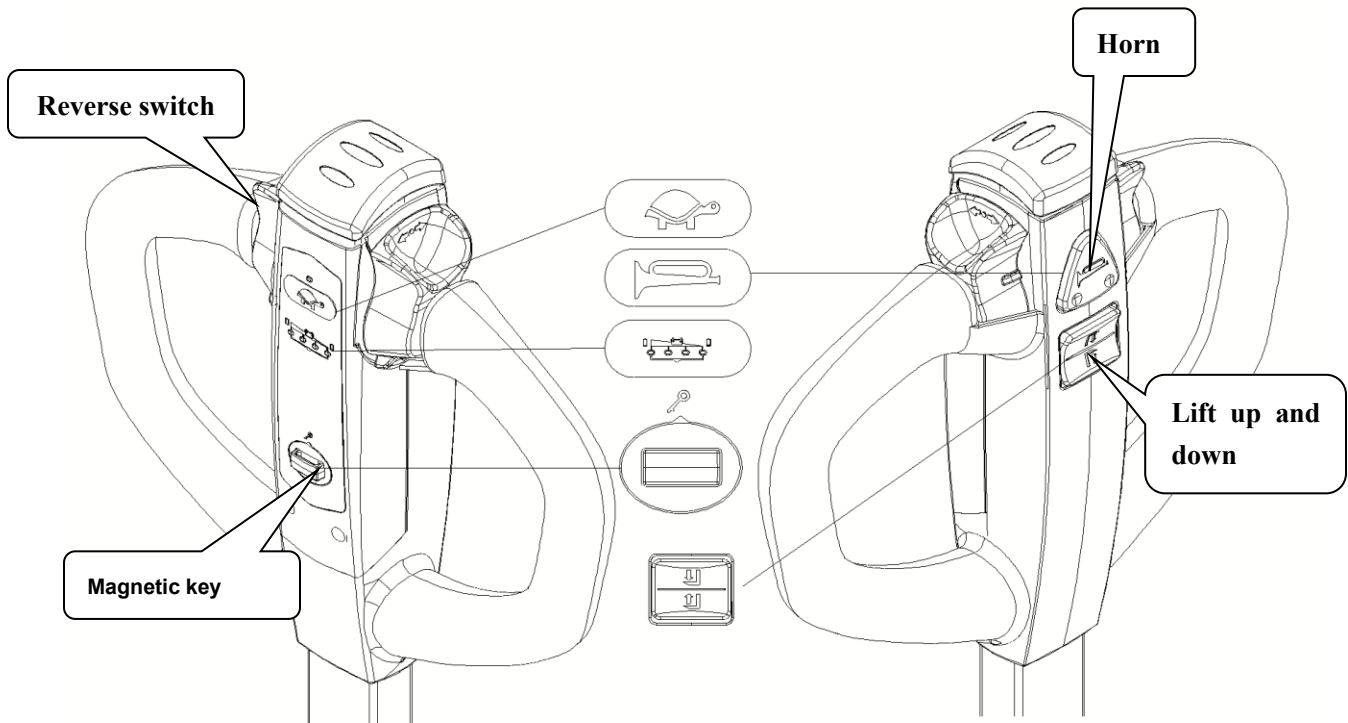

Emergency Stop and Control Buttons

- **Emergency Reverse Switch:** The red button at the top of the accelerator is an emergency stop. If activated, the stacker will immediately reverse direction.
- **Lift and Drop Buttons:**
 - **Lift:** The lift button, located on the right side above the rudder handle, raises the forks.
 - **Drop:** The drop button, located on the left side above the rudder handle, lowers the forks.
- **Horn Button:** The horn button, located in the middle above the rudder handle, sounds the horn.
- **Magnetic Key:** Insert the magnetic key into the tiller hole to power on the stacker. Remove the key to power off the stacker.

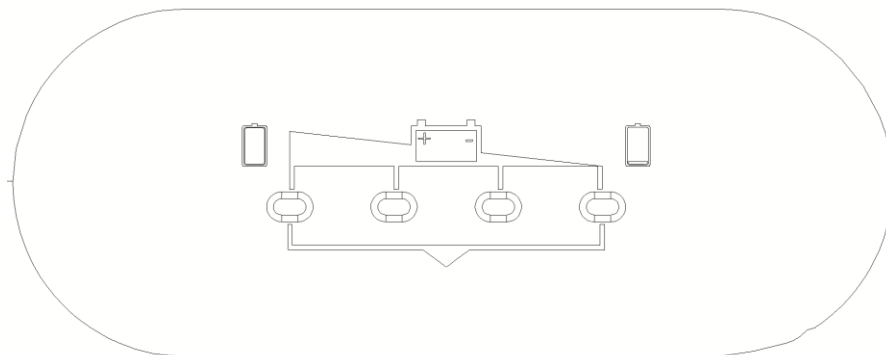

Battery Power Indicator

The electricity meter, which is activated by turning on the power switch and inserting the magnetic key, displays the battery power level using four indicator lights:

- **Sufficient Power:** The leftmost indicator light indicates that the battery has sufficient power for normal operation.
- **Low Power:** The middle indicator light indicates that the battery power is low and should be charged soon.
- **Critical Power:** The rightmost indicator light indicates that the battery power is critically low and requires immediate charging.

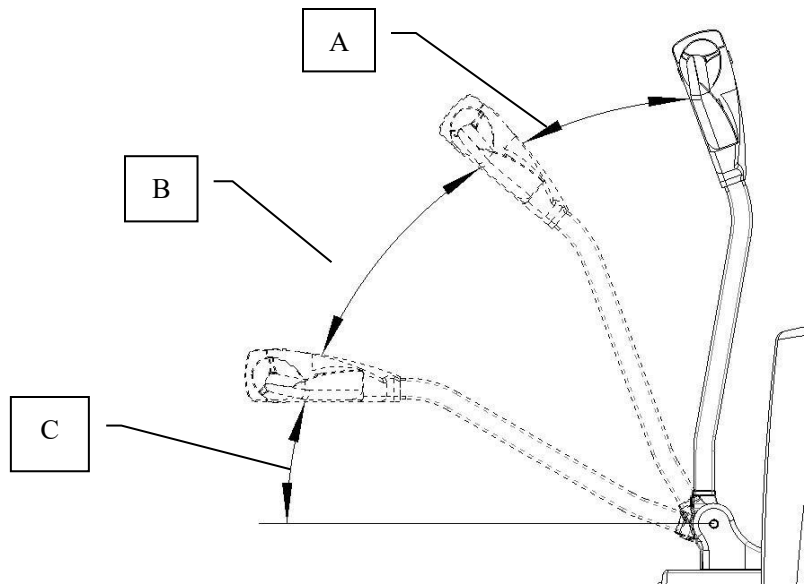

Running and Braking

The rudder handle has three vertical sections: A, B, and C.

- **Braking:** When the rudder handle is in either zone A or zone C, the stacker is in a braking state.
- **Running:** When the rudder handle is in zone B, the stacker is in normal running mode.

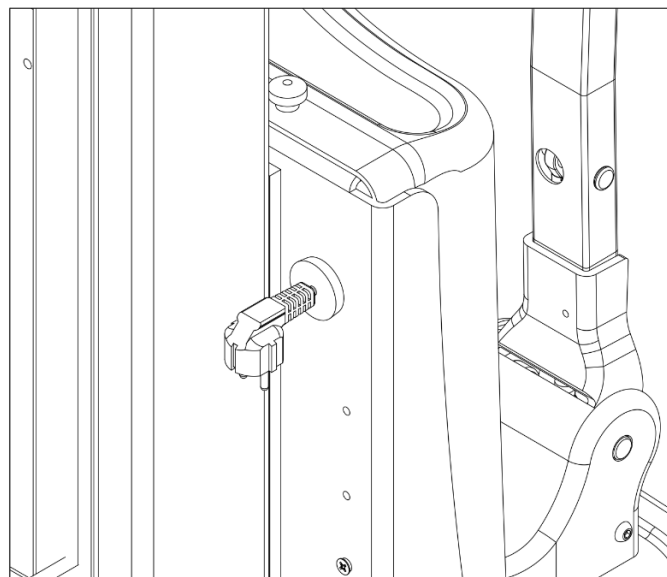

Charging the Stacker

The charging port is located on the stacker, as shown in Figure 2-6. The type of charger required depends on the stacker's configuration:

- **Built-in Charger:** The stacker has a built-in charger. Connect the power cord to the three-core socket on the stacker and to a standard power outlet.
- **External Charger:** The stacker requires an external charger. Connect the appropriate plug from the external charger to the two-core socket on the stacker.

04. Safety labels and guidelines

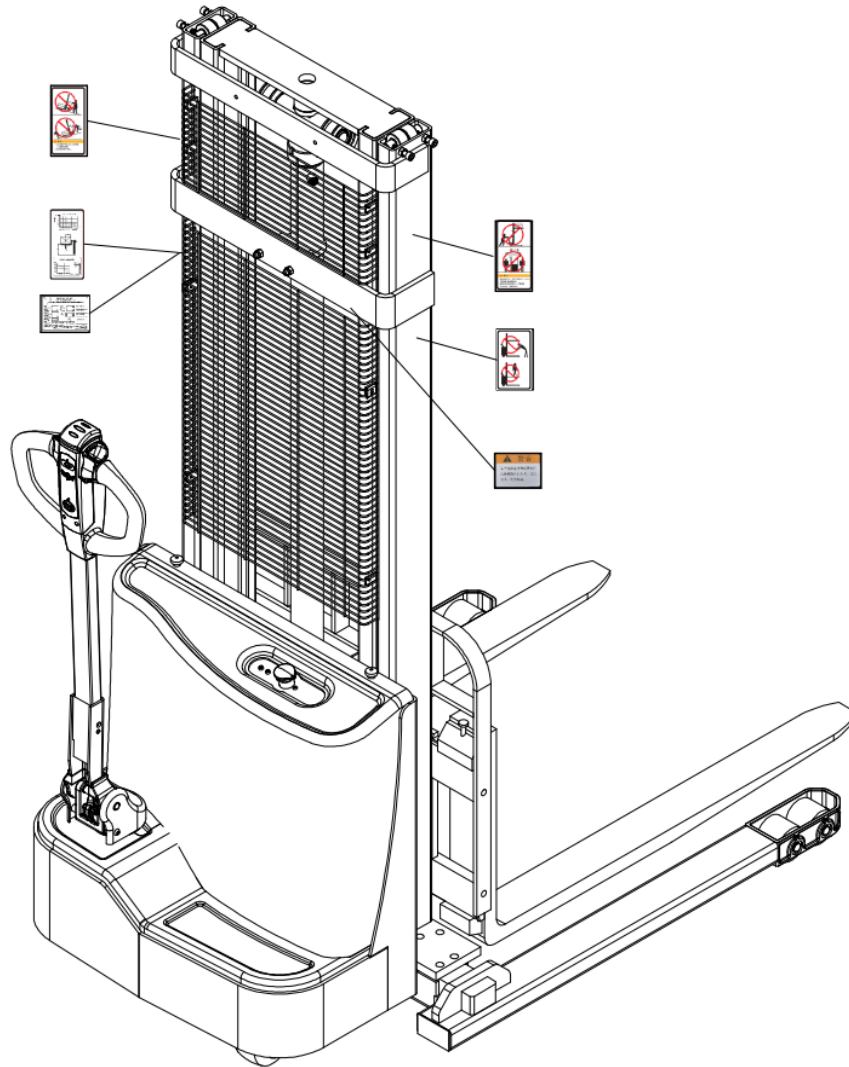

Figure 2-1

⚠️ Load curve: Please strictly adhere to the load curve indicated on the nameplate to avoid overloading the equipment.

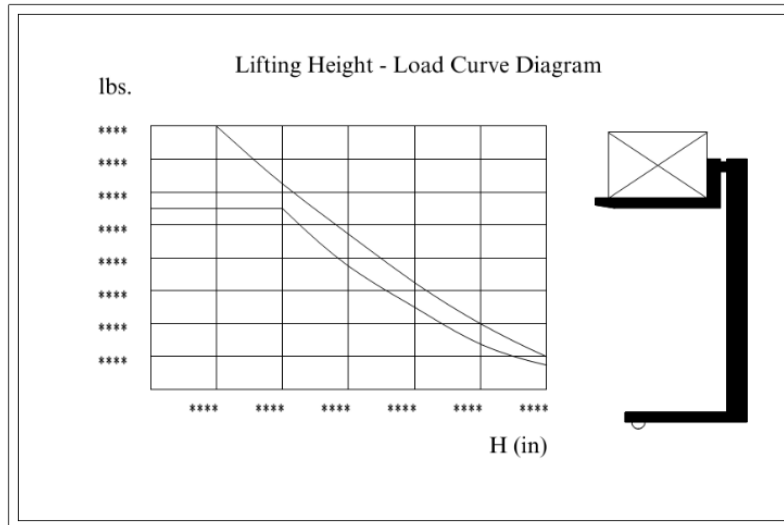
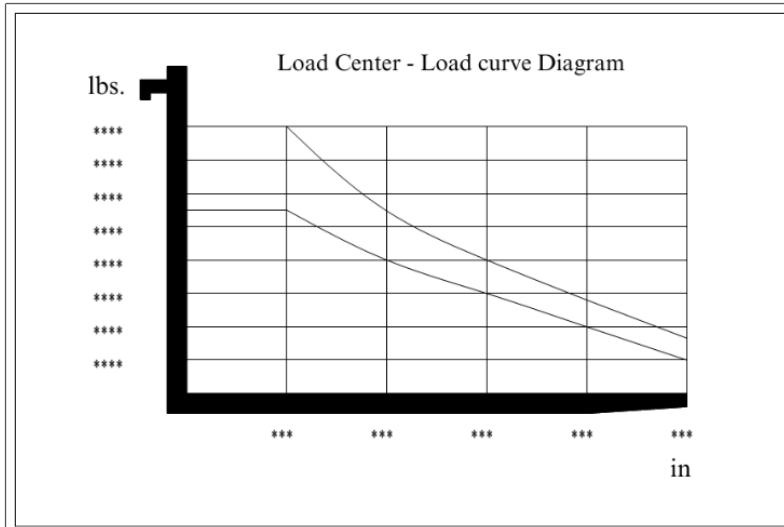

Figure 3-1

Figure 3-2

Data plate:

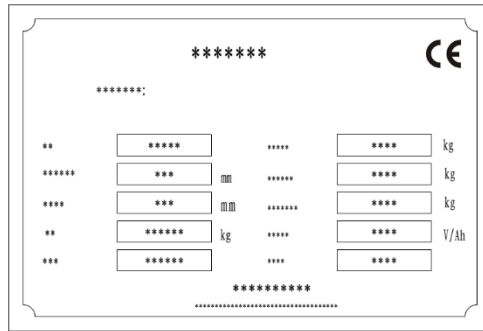

Figure 4-1

Trademark	maker	CE	
Model number		Rated load weight	lbs.
Maximum lifting height	in	Battery free weight	lbs.
Load center	in	Allowable battery weight	lbs.
Service Weight	lbs.	Voltage and Capacity	V/Ah
Serial number		Production date	

Warning labels:

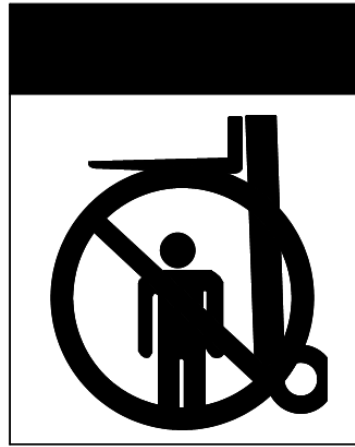

Figure 5-1



Figure 5-2

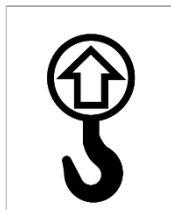

Figure 5-3

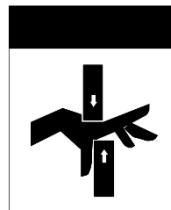

Figure 5-4

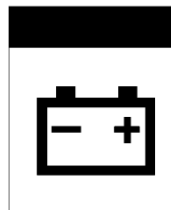
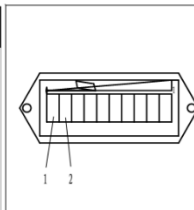

Figure 5-5



When the indicator light is flashing, the battery requires recharging. Stop using the truck and recharge the battery immediately. Further use while discharged may damage the truck.

Figure 5-6

1. This stacker can only be used on the flat floor indoors. Forbid being used in a corrosive environment such as acid, alkali or explosive condition.
2. Before operation, read the instruction carefully and check whether the stacker is in good condition. Forbid using trucks in malfunction and repairing it without any training.
3. Forbid overloading. The load capacity and lifting height should be within the rated.
4. The gravity center of the cargo should be positioned in the middle of the two forks. Unbalanced loading will cause turnover of the stacker. Forbid to load loosen cargo.
5. Drive stacker slowly while in and out of the shelves. Forbid starting and stopping stacker in a sudden. Forbid turning trucks among the shelves.
6. The forks can not be higher than 0.5 meter when stacker needs a long distance moving.
7. People are not permitted to stand under or beside the forks while loading.
8. Never allow climbing or riding on the forks.

Figure 5-7



Figure 5-8

- Figure 5-1:** Do not stand under a suspended load.
- Figure 5-2:** Do not stand on the forks.
- Figure 5-3:** Hoisting Points
- Figure 5-4:** Avoid Moving Parts. Moving parts can cause severe injury.
- Figure 5-5:** Charging Instructions
- Figure 5-6:** Battery Power Indicator
- Figure 5-7:** Forklift Operation
- Figure 5-8:** Do not stack loose cargo.

05. Battery operating conditions



Please use the battery at
14°F ~ 113°F



Avoid water, beverages,
and corrosive liquids near
the battery.



Keep batteries away from
heat sources, open
flames, flammable and
explosive gases (liquids)



Keep metal objects away
from the battery box, do
not pierce.

Charging environment



Charge the battery at an ambient
temperature of 32°F to 95°F.



Do not exceed 12 hours of charging to
avoid damaging the battery!

Important Battery Safety Tips:

1. **Battery Removal:** Never remove the battery without proper authorization, as it may cause leaks, overheating, fire, or explosion.
2. **Low-Temperature Charging:** Avoid charging the battery below 32°F (0°C) to protect the battery.
3. **Use Authorized Chargers:** Always use the original charger to prevent battery damage and potential hazards.
4. **Excessive Charging:** If the battery is not fully charged after 12 hours, stop charging and contact customer service for assistance.
5. **Battery Life:** To maximize battery life, keep the charge level between 20% and 90%. Start the accelerator slowly to avoid sudden power surges.
6. **High-Temperature Storage:** Avoid storing the battery in environments exceeding 113°F (45°C) to prevent irreversible damage.

7. **Low-Temperature Performance:** Battery capacity may decrease at low temperatures. Refer to the following:
 - 14°F (10°C): 70% capacity
 - 32°F (0°C): 80% capacity
 - 77°F (25°C): 100% capacity
8. **Long-Term Storage:** If storing the battery for an extended period, keep it at 50% charge and a temperature between 32°F and 68°F (0°C to 20°C). Charge and discharge the battery at least once a month to prevent capacity loss.
9. **Safe Storage:** Store the battery in a safe location to avoid accidental drops or impacts, which can lead to leaks, overheating, or fire.

06. Troubleshooting

Abnormal Condition	Cause of the problem	Elimination method
The meter does not display after the power switch is turned on	The 10A fuse on the panel of the electrical panel is blown or the power switch is damaged.	Replace the fuse or power switch.
The lifting height does not meet the design requirements	There's not enough hydraulic fluid in the tank	Add hydraulic oil
Hydraulic pump is operating but the fork is not lifting or lowering	The solenoid valve of the hydraulic station is blocked or stuck with dirt	Remove solenoid spool and clean with gasoline or kerosene
The power is on, but the lifting fork is not functioning	The lifting loop 175A fuse is blown or the battery protection controller is damaged.	Replace the fuse or battery protection controller. If the issue persists, check for short circuits or device damage.
Oil leakage or leakage	The sealing washer is damaged or invalid, or the thread joint is loose	Replace the seal ring and tighten the joint

Note:

- Ensure that a qualified technician performs the electrical work.
- Use the correct type and quantity of hydraulic fluid.
- Follow the manufacturer's instructions for maintenance and troubleshooting.

07. Maintenance and repair

To prolong the life of your stacker, we recommend regular maintenance and inspections. Even when not in use, periodic checks are essential.

Periodic Maintenance:

- **Initial Inspection:** Conduct the first maintenance check one month after purchase.
- **Regular Inspections:** Perform regular maintenance checks every six months.
- **Professional Service:** Engage an authorized EKKO service center for professional maintenance to ensure optimal performance.

Daily Maintenance:

- If you notice any abnormalities during your inspections, contact official customer service to schedule a maintenance appointment with an authorized service center.

Stacker Storage:

1. **Storage Location:** Store the stacker in a flat, stable, well-ventilated, and dry location.
2. **Environmental Protection:** Protect the stacker from direct sunlight and rain to prevent damage and aging.
3. **Cleaning:** Clean the stacker's body with tap water and a neutral detergent.
4. **Long-Term Storage:** Refer to the "Battery Usage Instructions" for long-term storage guidelines. Before using the stacker after prolonged storage, fully charge the battery.

Regular maintenance check items:

Maintenance item	Maintenance purpose
Brake	Ensure proper brake function to prevent accidents.
Tire	Detect tire damage to prevent heavy lifting and excessive power consumption.
Electric Door Lock, Battery Lock	Verify the functionality of electric locks and battery locks to prevent malfunctions.
Drive Wheel, Oil Pump	Check the condition of the drive wheel and oil pump to ensure proper stacking and transportation.
Line	Inspect the line connector and knots for damage or looseness to prevent line failure.
Screws	Verify the tightness of screws in critical areas to prevent loosening and falling off.
Battery	Check the battery's appearance and cell performance to prevent failures and extend its life.
Charger	Inspect the charger cable for damage and ensure the input and output connectors are secure.
Oiling	Check bearings for lubrication needs.
Cleaning	Clean the surface to remove dust.

Important Reminder:

1. **Upon Delivery:** Please inspect the stacker immediately upon receipt.
2. **Maintenance and Repairs:** If the stacker or its components require repair or replacement, please retain the relevant after-sales service documentation.

08. Hydraulic schematic diagram

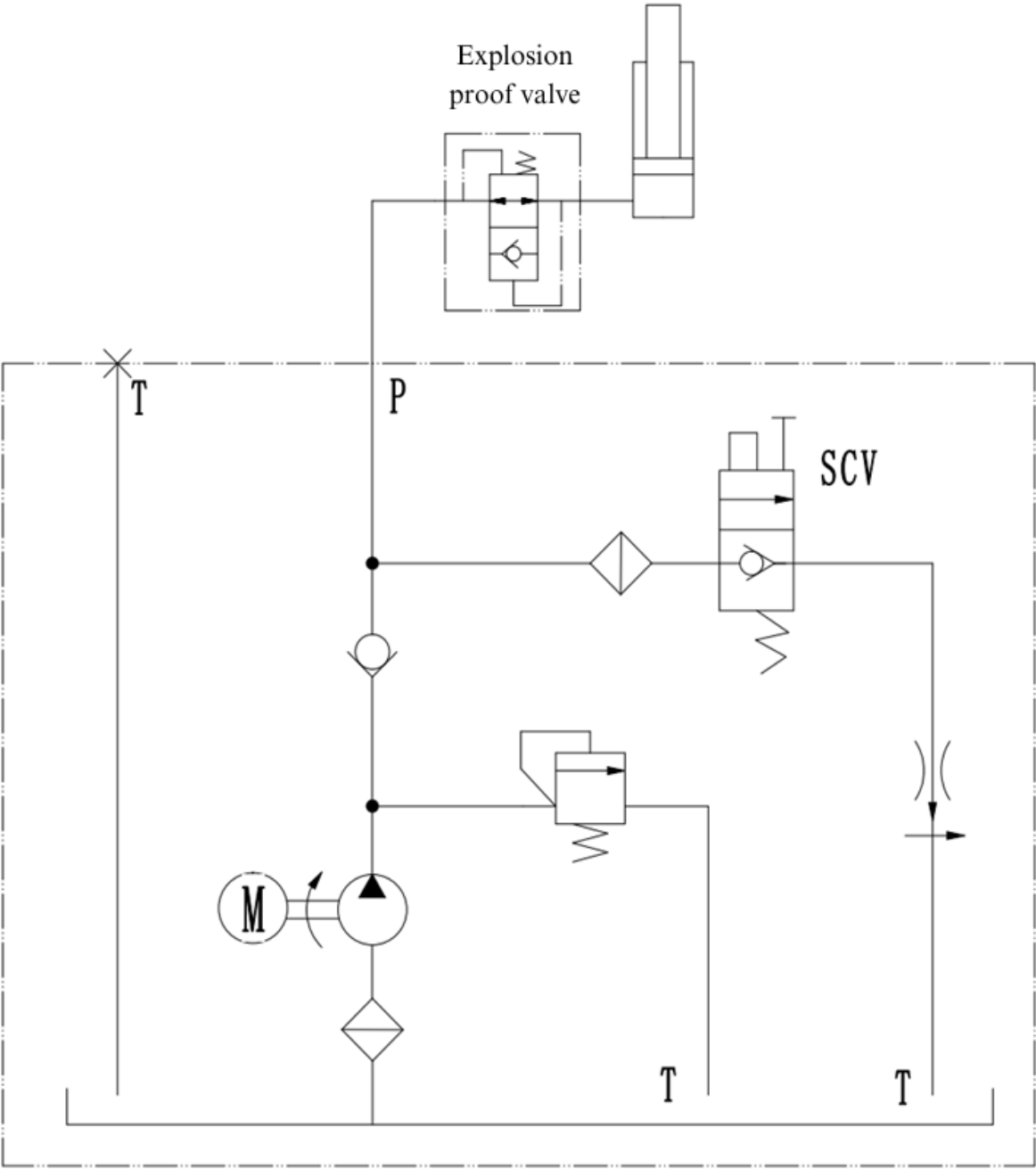

1. oil tank 2. oil filter 3. DC motor 4. gear oil pump 5. relief valve 6. check valve 7. Electromagnetic reversing valve 8. built-in balancing valve 9. cylinder

09. Electrical schematic diagram

