

Full Powered Straddle Stacker

EB20CS-177LI / EB20CS-189LI /
EB20CS-216LI

- 4400 lbs. load capacity
- Lift height 177-216"
- Lowered Mast Height 79.3-92.9"
- Polyurethane Tires
- Lithium Battery 24V/150Ah
- Charger Included
- AC Drive Motor
- Side Shift



Straddle Stacker

EB20CS-177LI / EB20CS-189LI / EB20CS-216LI

EB20CS-177 / 189 / 216LI		
Power Type	Electric	
Driving Mode	Walk-behind	
Rated Load Capacity	Q (lb.)	4400
Load Centre Distance	c (in)	24
Wheelbase	y (in)	57
Tire Type, Drive Wheel/Load Wheel		Tire Material Polyurethane
Drive Wheel Size (Diameter × Width)	in	Φ9.8x2.8
Load Wheel Size (Diameter × Width)	in	Φ3.1x2.8
Number of Vehicles (X = Drive Wheel)		1X+4
Height with Mast Fully Retracted	h1 (in)	79.3 / 83.1 / 92.9
Lift Height	h3 (in)	177 / 189 / 216
Maximum Height with Mast Extended	h4 (in)	206.3 / 217.7 / 245.6
Minimum Fork Height	h13 (in)	2.6
Overall Length	l1 (in)	81.9
Inner Width of Legs	in	39.8/43.7/47.6/51.6/55.5
Fork Dimensions	s/e/l	1.4x3.9x45.3
Fork Adjustment Range (Outside Width of Forks)	b5 (in)	8.7 - 32.1
Minimum Ground Clearance at Wheelbase Center	m2(in)	1.2
Minimum Turning Radius	Wa (in)	65
Travel Speed, Laden/Unladen	mph	9/10
Gradient Performance, Laden/Unladen	%	3/10
Service Brake		Electromagnetic
Driver Motor Power	kw	1.5
Lift Motor Power	kw	3
Battery Voltage/Rated Capacity	(V)/(Ah)	Lithium 24/150
Charger	(V)/(A)	24V/50A
Type of Drive Control		AC
Steering Type		EPS

Straddle Stacker



EB20CS-177LI / EB20CS-189LI / EB20CS-216LI

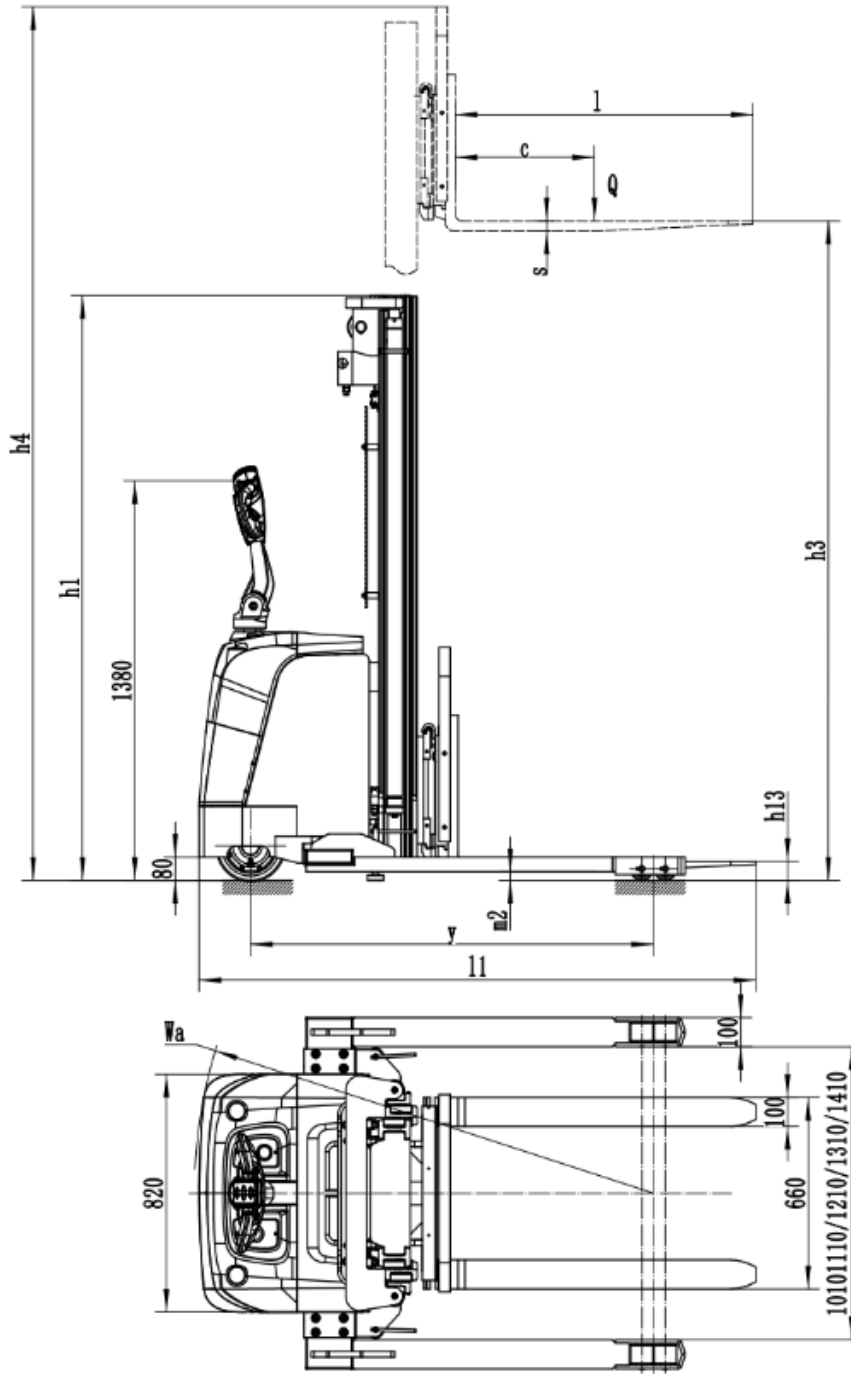

MODEL #	MAST	LIFT HEIGHT	MAX MAST HEIGHT	SERVICE WEIGHT
EB20CS-177LI	79.3"	177"	206.3"	2970 Lbs.
EB20CS-189LI	83.1"	189"	217.7"	3000 Lbs.
EB20CS-216LI	92.9"	216"	245.6"	3130 Lbs.



1761 W. Holt Ave.
Pomona, CA 91768 USA

AUTHORIZED DEALERS ONLY
www.ekkolifts.com

T: (877) 232-6517 F: (909) 222-6861