

EKKO

MATERIAL HANDLING EQUIPMENT

MOVING AHEAD

Lithium Order Picker

EOP22-LI Series



- 220 lbs. Capacity
- 165 | 216 in. Lift Height
- Electronic Power Steering (EPS)
- AC Drive Motor
- Polyurethane Tires
- Curtis® Controller
- 24V/200Ah Lithium Battery
- 24V / 50Ah Charger
- Batteries & Charger Included
- 3-Year Limited Warranty

Superior quality, maneuverable, compact, and durable for all your material handling applications.

WEIGHT CAPACITY: 220 lbs. @ 16" load center

LIFT HEIGHT: 165" | 216"

LOWERED HEIGHT: 94"

TURNING RADIUS: 57"

BATTERY: 24V/200Ah

BATTERY REPLACEMENT METHOD: Hoist-Lift Type

CHARGER: 24V/50Ah

SPEED TRAVEL: up to 3.10 mph

DRIVE WHEELS: polyurethane

OVERHEAD GUARD HEIGHT: 76"

WHEELBASE: 49"

FRONT OVERHANG: 6.7"

Drive Motor/Lift Motor Power: 1.5KW / 3KW

LOAD WHEELS: (2) 4" x 3" polyurethane per outrigger

HYDRAULICS LIFTING MOTOR: 24V 2200 Watt lifting motor with hardened chrome moly steel for durability.

OPERATION TYPE: Standing

DRIVE MOTOR: AC drive motor for efficiency and high torque.

AC CONTROLLER: 24V CURTIS Instrument provides performance through entire range of speed; Constant travel speed regardless of load; Battery discharge indicator combination gauge.

CHASSIS WIDTH: 32 x 37"

BRAKES: Electro-magnetic braking for secure stopping power; Electronic neutral braking for accurate control.

Lithium Order Picker

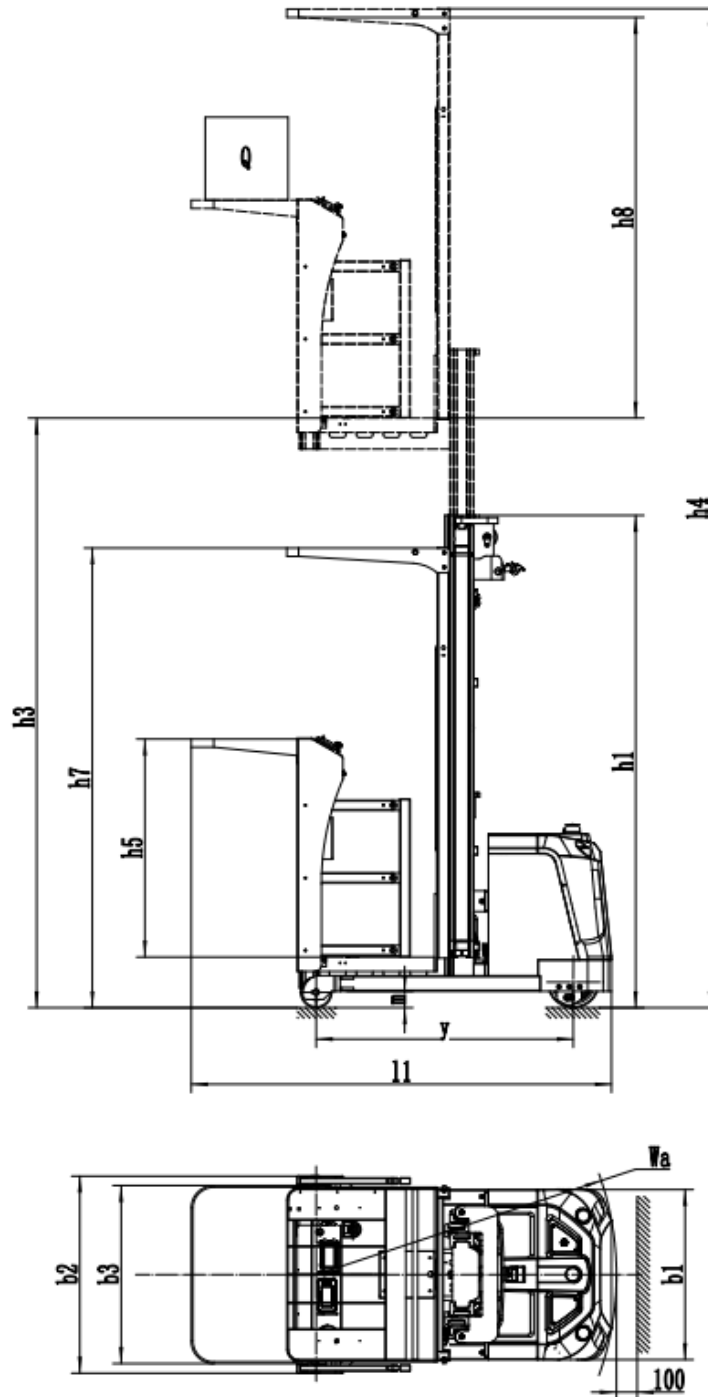

MODEL #	Capacity	LIFT HEIGHT	Charger	Battery
EOP22-165LI	220	165"	24V/50Ah	24V/200Ah Lithium
EOP22-216LI	220	216"	24V/50Ah	24V/200Ah Lithium