



Electric Counterbalance Forklift Truck Series
EK18GS / EK18GSH / EK20GS / EK25GB / EK25GHB /
EK30GB / EK35GB
Parts Manual



目 次
Contents

FOREWORD.....	2
零件图册说明.....	3
INSTRUCTION FOR PARTS MANUAL.....	4

FOREWORD

Thank you for selecting truck designed and manufactured by EKKO.

The manual is an integral part of the truck. Please keep it and other technical documents well during the life cycle of the truck and operate the truck according to instructions.

When you replace parts or components, please apply the real goods made by our company to ensure the truck's quality. The parts of this product will be improved at the later stage, you can get the latest information from the company's sales and accessories company.

We reserve the right to modify the catalogue for improvement without notice.

零件图册说明

缩写说明

ASS'Y	总成
R.H.	右
L.H.	左
H.P.	高压
L.P.	低压
M	基本型
ZM	二级全自由
ZSM	三级全自由
ZFM	四级全自由
Metric	公制
SAE	美制
AR	按需

特定词语说明

公制:表示面向一般市场而制造的专用零件

美制:表示向美国和加拿大出口而制造的专用零件

特殊符号说明

☆	表示购买该零部件时,请咨询当地经销商/代理商
图号加 DB	表示打包销售的打包件
转向桥总成加"-X"	表示不带减震垫和支架的转向桥总成,可以打包销售
滤清器的图号加"X"	表示该滤清器的滤芯
图号加"XLB"	表示零部件的修理包

INSTRUCTION FOR PARTS MANUAL

Abbreviations in the CATALOGUE:

ASS'Y	Assembly
R.H.	Right
L.H.	Left
H.P.	High pressure
L.P.	Low pressure
M	Basic type
ZM	Two-stage free lifting
ZSM	Three-stage free lifting
ZFM	Four-stage free lifting
Metric	Parts made for common forklift trucks markets
SAE	Special parts made for the forklift trucks exported to US and Canada
AR	As required

Terms instructions:

Metric: Parts made for common forklift trucks markets

SAE: Special parts made for the forklift trucks exported to US and Canada

Signs instructions:

☆	It means when you are purchasing this part, please consult local dealer/agent.
Figure number with "DB"	It is for the package sold as a unit, It is for selling as a unit.
Steering axle assembly with "-X"	It refers to steering axle without cushions and support bracket.
Figure number of filter with "X"	It refers to the filter core of the filter.
Figure number with "XLB"	It refers to the repair kits for the part.

EK18/20/25/30/35 SERIES 4 WHEEL FORKLIFT



EKKO 4 Wheel Electric Forklift

序号 No.	零部件代号 Part No.	版本 Edition	名称 Part name		数量 Q'ty	备注 Remark	
1	A1TV2-40001	01	Electrical system	电气系统	1		
2	A1753-00001	02	Drive axle assembly	驱动桥总成(单胎人力制动)	1	Choose a single tire	选单胎
3	A1753-00011	02	Drive axle assembly	驱动桥总成(双胎人力制动)	1	Choose twins	选双胎
4	HRA1754401	01	Front wheel ass'y	车轮总成	1		
5	HRA1754101	00	Steering mounting system	转向安装系统	1		
6	ABG74-30001B	00	Steering axle	横置油缸转向桥	1	Standard, no synchronous steering, no turning speed limit	标配, 不装同步转向, 不带转弯限速
7	ABG74-30001	05	Steering axle	横置油缸转向桥	1	Optional, with synchronous steering or turning speed limit	选配, 装同步转向或转弯限速
8	ABG74-30001N	00	Steering axle	横置油缸转向桥	1	Optional with synchronous steering and cornering speed limit	选配, 装同步转向和转弯限速
9	A1755-40001	02	Service brake system	行车制动系统	1		
10	ABG73-60001	02	Hand brake assembly	手制动装置总成	1		
11	HRA1TV6101	00	Frame assembly	车架总成	1		
12	HRA1TV6301	00	Counterweight system	平衡重系统	1		
13	HRA1TP6401	00	Hood	机罩类	1		
14	HRA1TP6501	01	Floor class	地板类	1		
15	HRA6S58001	08	Seats	座椅总图	1	Standard: A7V96-80002	标配: A7V96-80002
16	A1755-70001	01	Cab	驾驶室	1	Optional	选配
17	A1755-70001KD	00	H4 overhead air conditioning cab assembly	H4 顶置空调驾驶室总成	1	Optional	选配
18	HRA1755901	00	H4 series windshield assembly	H4 系列挡风玻璃类总成	1	Optional	选配
19	HRA1751301	01	Fire extinguisher assembly	灭火器总成	1		
20	A22A0-00021	00	Backup mirror	倒车镜	2		
21	A1757-60001	04	Hydraulic pipeline system	液压管路系统	1		
22	HRA1755101	01	Roof guard assembly	护顶架总成	1		
23	HRD2BP8001	02	Lifting system	起重系统总成(M)	1		
24	HRDH2G8001	02	Lifting system (ZM), 2-2.5t	2-2.5t 起重系统(ZM)	1		
25	HRDH2N8001	02	2-2.5T Lifting system	2-2.5T 起重系统(ZSM)	1		

EKKO 4 Wheel Electric Forklift



A1TV2-40001 01 Electrical system

A1TV2-40001 01 电气系统

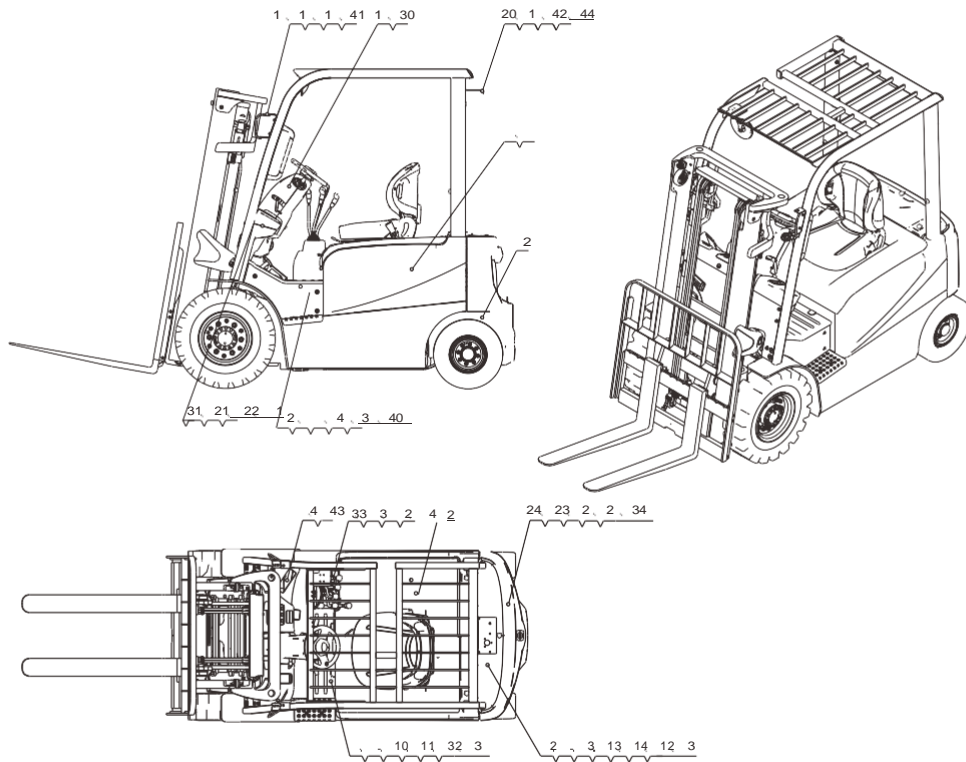

A1TV2-40001 01 Electrical system

A1TV2-40001 01 电气系统

序号 No.	零部件代号 Part No.	版本 Edition	名称 Part name		数量 Q'ty	备注 Remark	
1	A1TP2-40021	00	Principle diagram	电气系统原理图	1	Songzheng electronic control selection	松正电控选用
2	A1TV2-40031	00	Control assembly	电控总成	1	Refer to HRA175240 4, 2-2.5 low configuration	参考 HRA175240 4, 2-2.5 低配
3	A1TP2-40041	00	Wire harness,body	车身线束	1	Songzheng electronic control	松正电控
5	A1TV2-40061	00	AC tractor motor	交流牵引电机	1		
6	A1TV2-40071	00	AC pump motor	交流泵电机	1		
8	A1TV2-43011	00	Cable	电缆连接线	1	Reference resources HRA1TP240 1	参考 HRA1TP240 1
9	A1TV2-43021	00	Cable	电缆连接线	1	Reference resources HRA1TP240 1	参考 HRA1TP240 1
10	A1TV2-43031	00	Cable	电缆连接线	1	Reference resources HRA1TP240 1	参考 HRA1TP240 1
11	A1TV2-43041	00	Cable	电缆连接线	1	Reference resources HRA1TP240 1	参考 HRA1TP240 1
12	A1TV2-43051	00	Cable	电缆连接线	1	Reference resources HRA1TP240 1	参考 HRA1TP240 1
13	A1TV2-43061	00	Cable	电缆连接线	1	Reference resources HRA1TP240 1	参考 HRA1TP240 1
15	A1752-40641	01	Transition line for rear light of roof guard	护顶架后灯过渡线	1		
16	D08HLQZD	01	LED resultant headlights	LED 合力前照灯	2		
17	A6V92-40371	02	Cable	LED 灯过渡线	2		
18	A6V92-40361	01	Front lamp	LED 前小灯	2		
19	D08HLHWD	01	Rear combination lamp	LED 后组合灯	2		
20	A79S2-40111	02	Horn	喇叭 DL124ED	1		
21	A79S2-43702	00	Horn filter	喇叭滤波器	1		
22	A1802-40091	00	Electric box	集成电器盒	1		
23	A61S2-41301	06	Back buzzer	倒车蜂鸣器	1		
24	A65F2-41701H	00	Speed adjust sensor	起升调速传感器	1		
25	A63K2-40501	04	Pedal accelerator	踏板加速器	1		
28	XB2-BS542	01	Emergency switch	急停开关	1		
30	A7S92-40261	03	Parking brake switch	停车制动开关(不带铁片)	1		

A1TV2-40001 01 Electrical system

A1TV2-40001 01 电气系统

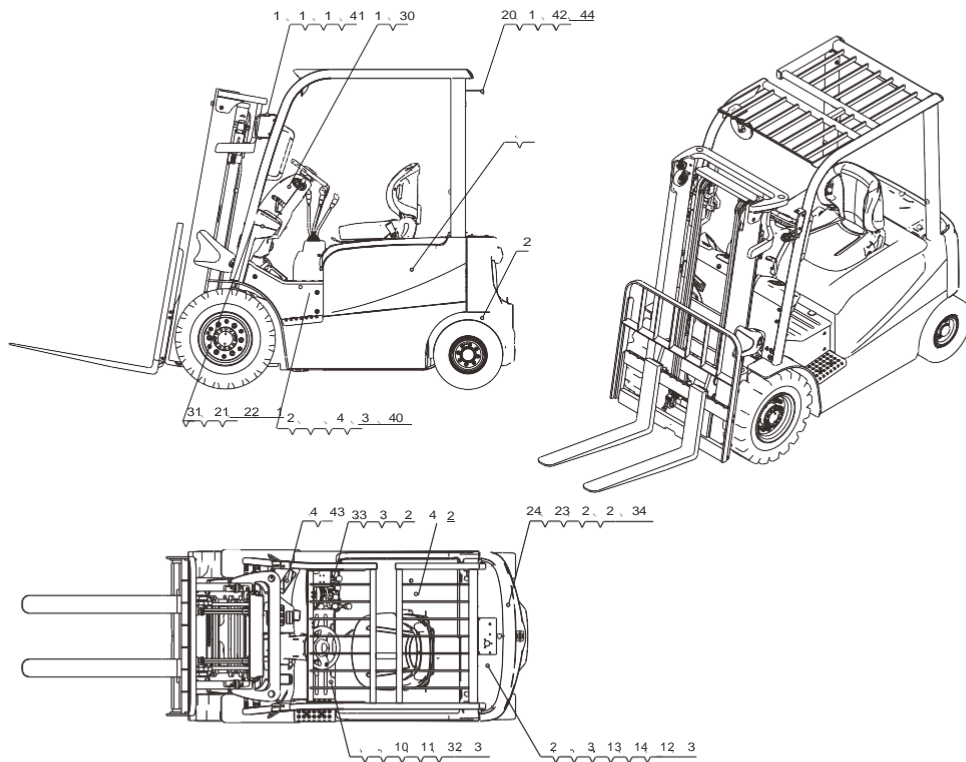

A1TV2-40001 01 Electrical system

A1TV2-40001 01 电气系统

序号 No.	零部件代号 Part No.	版本 Edition	名称 Part name		数量 Q'ty	备注 Remark	
31	D09JK205B	01	Brake switch	脚制动开关	1		
33	ADL72-40401	00	Commutator	DC-DC 转换器	1		
34	D12-7427151	00	Magnetic ring	电机连接线磁环	12		
35	HRA1752407	00	Electrical options	电气选配项	1	Optional	选配
37	D03XK0367	00	Support	线束固定卡	9		
38	D03XK0366	00	Support	线束固定卡	5		
39	D03XK0195	00	Support	线束固定卡	7		
40	A6V72-41001	00	Rubber ring	出线胶圈	2		
41	H24C2-40701	01	Dusty ring	防尘胶圈	1		
42	G2KE2-43801	00	Dusty ring	防尘胶圈	2		
43	H43E2-43601	00	Rubber ring	出线胶圈	2		
44	SY2985-BLK	02	Hood	电机电枢护套	12		
45	B4123-00008	00	Nut	螺母 M8	2	GB6171-86	GB6171-86
46	B1210-06016-X	00	Combination screw	组合螺钉 M6x16	4	GB 9074.4-88	GB 9074.4-88
47	B1210-06012	00	Screw	螺钉 M6x12	4	GB5783-86	GB5783-86
48	B0330-05012	00	Bolt M5x12	螺栓 M5x12	2	GB5783-86	GB5783-86
49	B4123-00005	00	Nut M5	螺母 M5	2	GB6170-86	GB6170-86
50	B1210-04010	00	Screw	十字槽盘头螺钉 M4X10	1	GB818-85	GB818-85
51	B1210-04008	00	Screw	螺钉 M4*8	2	GB818-85	GB818-85
52	B5050-00008	00	Washer	垫圈 8	8	GB93-87	GB93-87
53	B5310-00008	00	Washer	垫圈 8	8	GB97.1-85	GB97.1-85
54	B5310-00006	00	Washer,lock	垫圈 6	6	GB97.1-85	GB97.1-85
55	B5050-00006	00	Washer,lock	垫圈 6	6	GB93-87	GB93-87
56	B5310-00005	00	Washer	垫圈 5	4	GB97.1-85	GB97.1-85
57	B5050-00005	00	Washer	垫圈 5	2	GB93-87	GB93-87
58	B5310-00004	00	Washer	垫圈 4	3	GB97.1-85	GB97.1-85
59	B5050-00004	00	Washer	垫圈 4	3	GB93-87	GB93-87
60	A7CL2-40071	00	USB port	USB 接口	1	Optional	选配
61	A1752-42171	00	Cable	转弯限速过渡线	1	Turning speed limit optional	配转弯限速选用
62	SY2982-BLK	00	Sleeve	接线柱护套	2		
63	A7G52-40121	00	Combined switch cover plate	组合开关盖	1		

A1TV2-40001 01 Electrical system

A1TV2-40001 01 电气系统

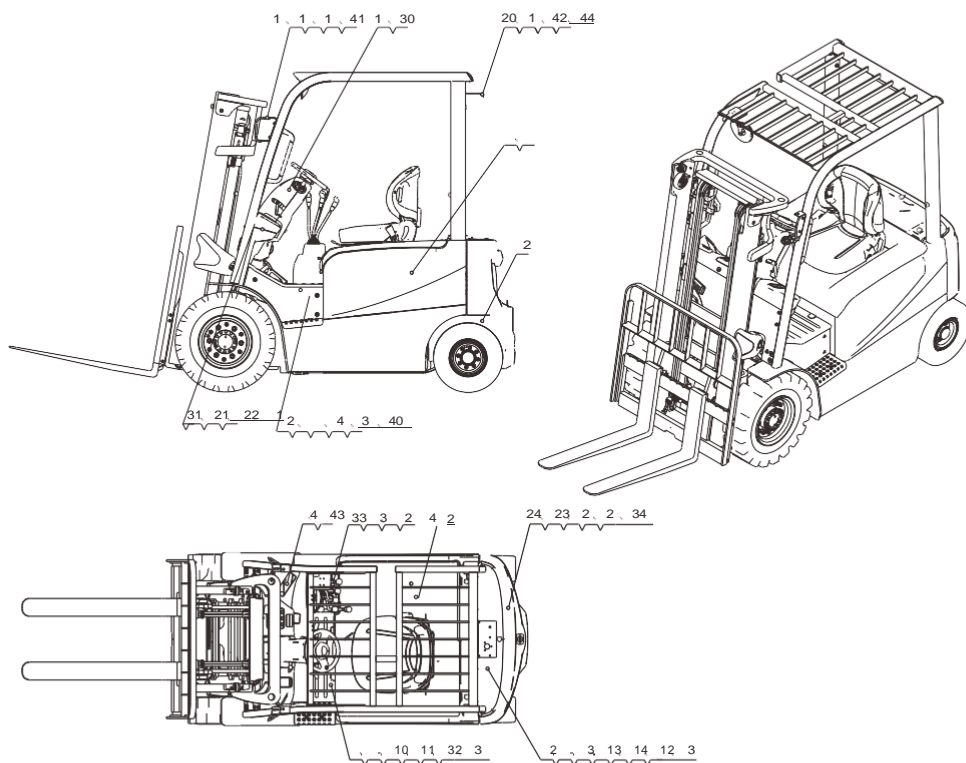

A1TP2-40021 00 Principle diagram

A1TP2-40021 00 电气系统原理图

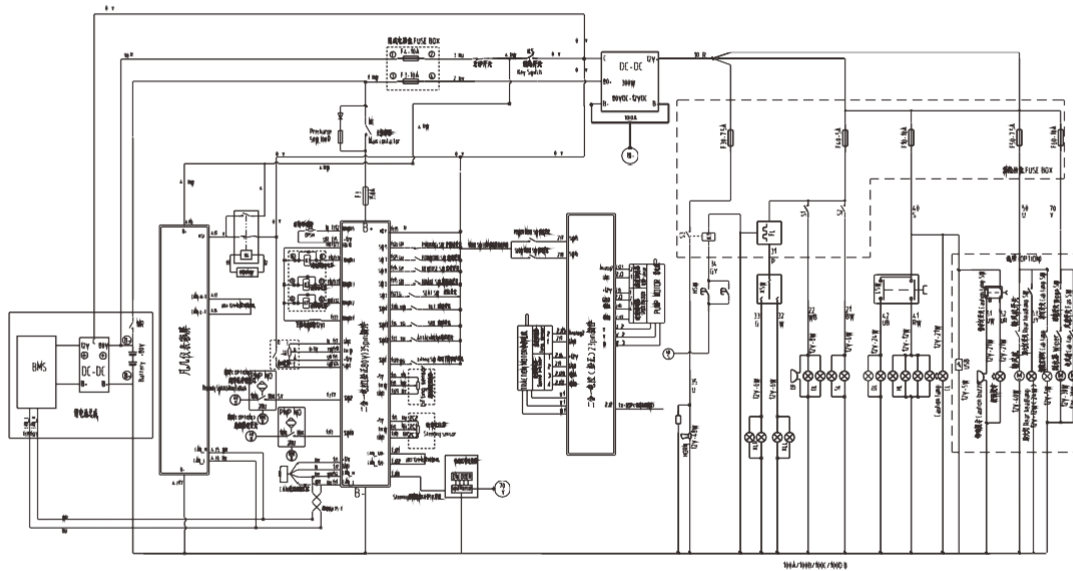

A1TV2-43011 00 Cable

A1TV2-43011 00 电缆连接线

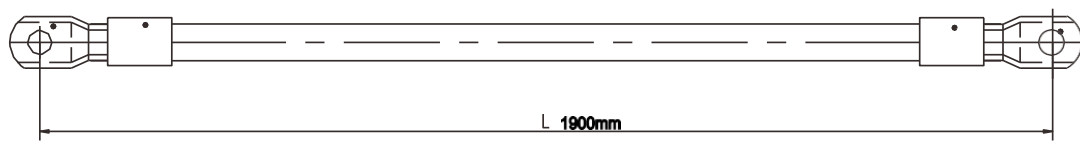

A1TV2-43021 00 Cable

A1TV2-43021 00 电缆连接线

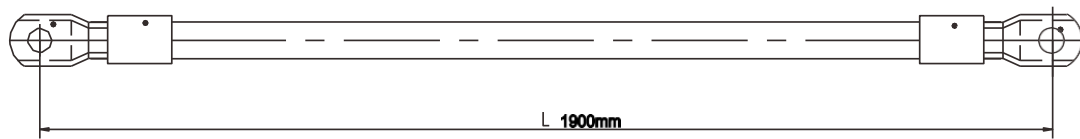

A1TV2-43031 00 Cable

A1TV2-43031 00 电缆连接线

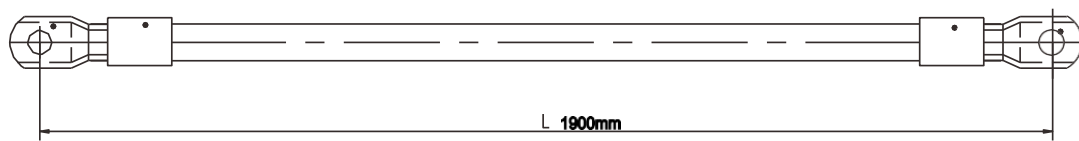

A1TV2-43041 00 Cable

A1TV2-43041 00 电缆连接线

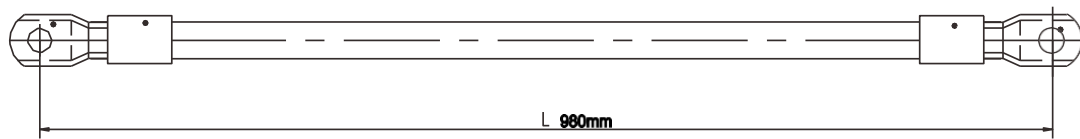

A1TV2-43051 00 Cable

A1TV2-43051 00 电缆连接线

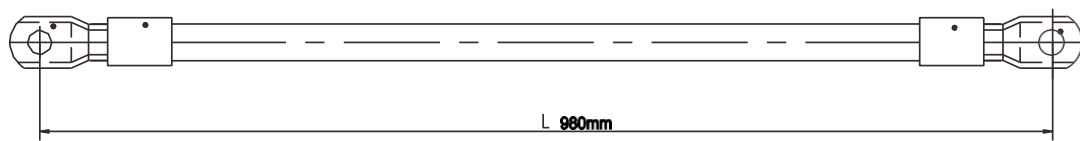

A1TV2-43061 00 Cable

A1TV2-43061 00 电缆连接线

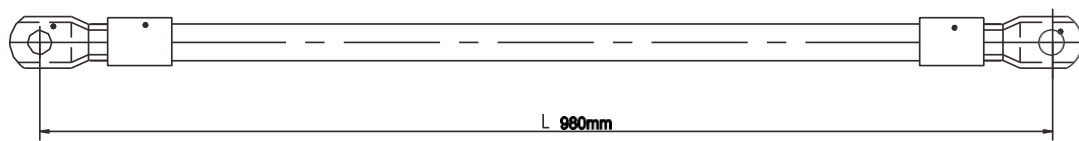

A1802-40091 00 Electric box

A1802-40091 00 集成电器盒

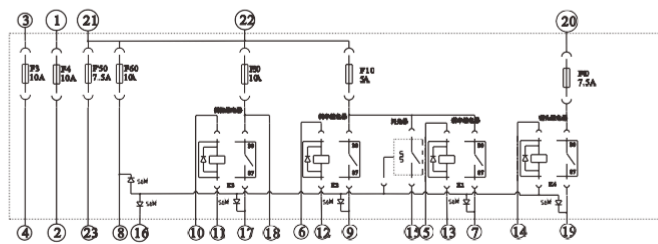
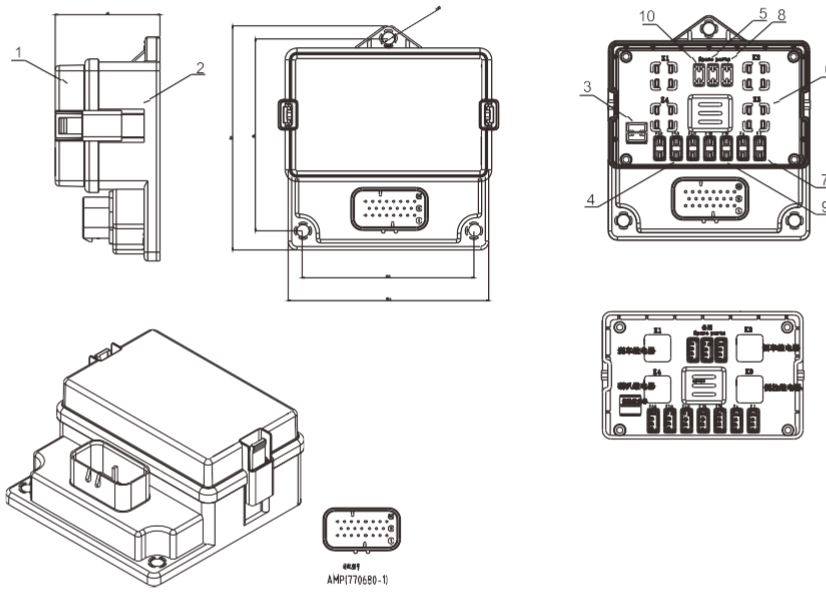

A63K2-40501 04 Pedal accelerator

A63K2-40501 04 踏板加速器

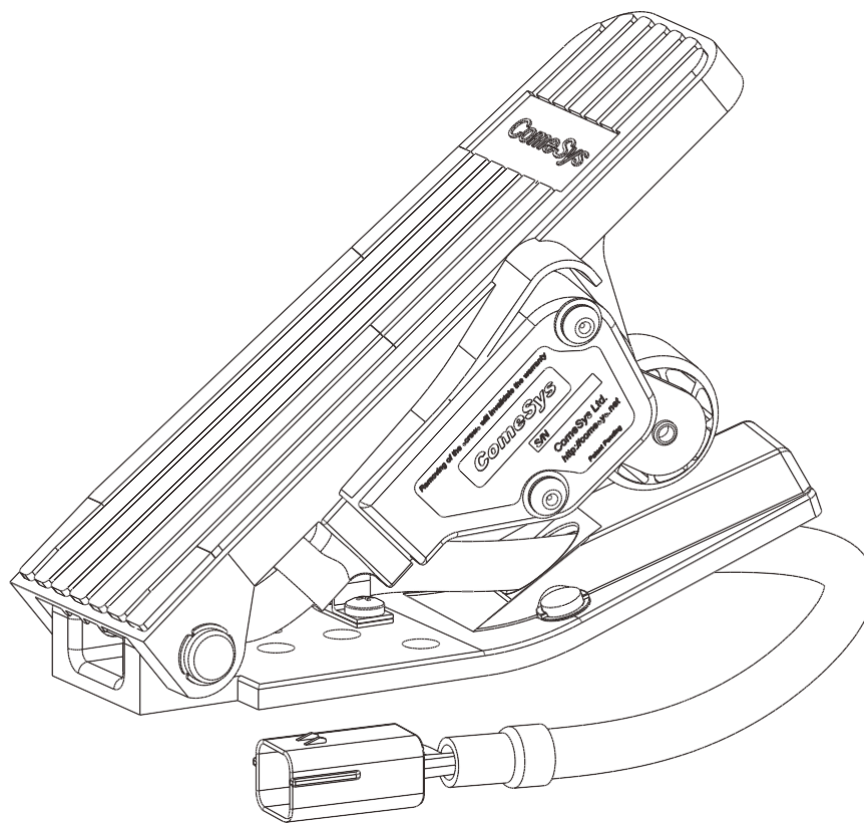

A7S92-40261 03 Parking brake switch

A7S92-40261 03 停车制动开关(不带铁片)

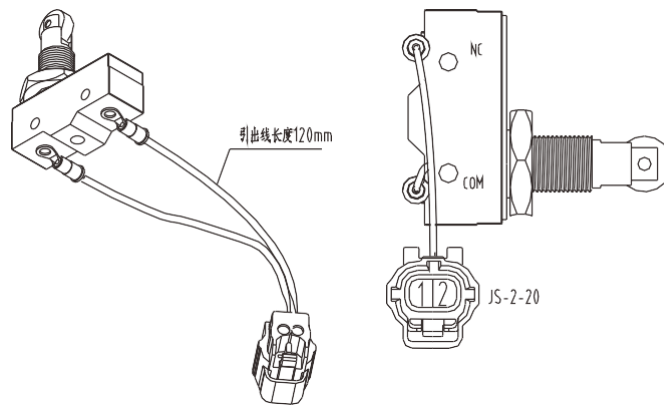

A1753-00001 02 Drive axle assembly

A1753-00001 02 驱动桥总成(单胎人力制动)

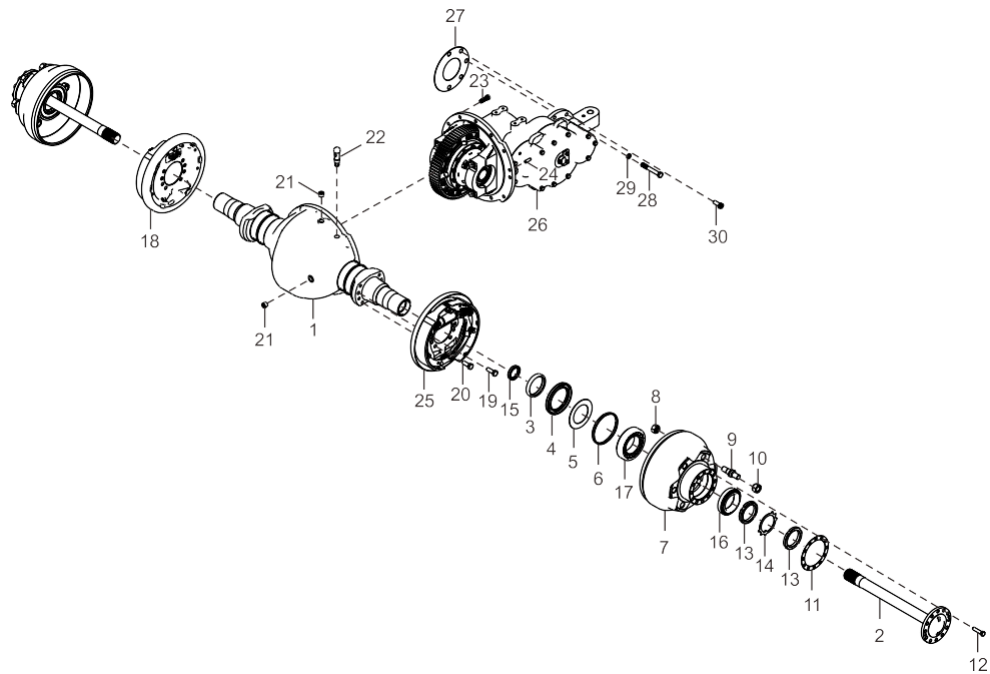

A1753-00001 02 Drive axle assembly

A1753-00001 02 驱动桥总成(单胎人力制动)

序号 No.	零部件代号 Part No.	版本 Edition	名称 Part name		数量 Q'ty	备注 Remark	
1	ACS73-02001	00	Housing,axle	桥壳 (2-2.5t)	1		
2	H9BA3-02011	03	Half,shaft	半轴	2		
3	H9BA3-02061	01	Snap ring	油封挡圈	2		
4	H9BA3-02051	00	Ring,seal	油封	2		
5	H24N3-02071	02	Ring	挡油环	2		
6	H24N3-02061	01	Snap ring	挡环	2		
7	H9DL3-02011	02	Hub	整体式制动鼓轮毂(2-2.5t)	2		
8	B4223-00020	00	Nut	螺母 M20x1.5	12	GB6171-86	GB6171-86
9	24353-72001	03	Bolt	柱螺栓	12		
10	24354-32311	01	Nut	锥螺母	12		
11	H24N3-02081	01	Packing	半轴垫(双胎)	2		
12	24453-02061	03	Bolt	螺栓	24		
13	A7S33-02331	01	Nut	圆螺母 M75X2	4		
14	B5512-00075	00	Washer 75	垫圈 75	2	GB858-88	GB858-88
15	HK2S3-02031	03	U-shaped seal 48x62x10	U型密封圈 48x62x10	2		
16	Z-32015	00	Bearing 32015	轴承 32015	2	GB/T 297-94	GB/T 297-94
17	Z-32216	00	Bearing	轴承	2	GB/T297-94	GB/T297-94
18	REF000560R	02	Wheel brake assembly(right)	制动器总成(右)	1		
19	25953-72001	03	Bolt	螺栓	4		
20	A22A3-02051	03	Bolt	螺栓	12		
21	22193-03001	02	Plug	堵塞	3		
22	22253-02063C	01	Breather plug	透气塞	1		
23	B0530-12040-X1	00	Combined bolt M12x1.25x40	组合螺栓 M12x1.25x40	12	GB5786,GB 93	GB5786,GB 93
24	B3120-10030	00	Pin B10x30	销 B10x30	1	GB119-86	GB119-86
25	REF000560L	02	Wheel brake ass'y(left)	制动器总成(左)	1		
26	A1753-00201	00	Reduction assembly	减速器总成	1		
27	A7X53-02171	04	Gasket	纸垫	1		
28	B0430-14090	00	Bolt M14x1.5x90	螺栓 M14x1.5x90	1	GB5785-86	GB5785-86
29	B5050-00014	00	Washer	垫圈 14	1	GB93-87	GB93-87
30	B0530-14040-X	00	Combined bolt M14x1.5x40	组合螺栓 M14x1.5x40	4	GB5786,GB 93,GB97.1	GB5786,GB 93,GB97.1

REF000560R 02 Brake assembly, right

REF000560R 02 制动器总成右

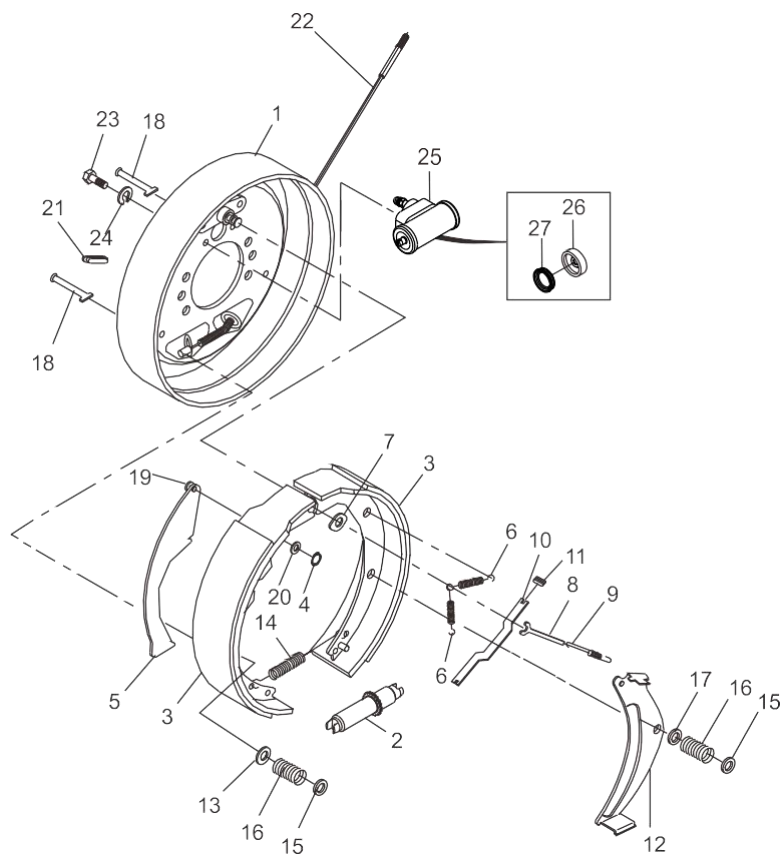

REF000560R 02 Brake assembly, right

REF000560R 02 制动器总成右

序号 No.	零部件代号 Part No.	版本 Edition	名称 Part name		数量 Q'ty	备注 Remark	
1	23653-73111	00	Back plate ass'y R.H.	制动器底板总成右	1		
2	23653-72441	00	Adjust R.H.	间隙调整器右	1		
3	23653-73021	01	Brake shoe & friction plate assembly	制动蹄带摩擦片总成	2		
4	A01C3-72621	00	Snap ring,pin axle	杆销挡圈	1		
5	23653-72071A	00	Lever brake R.H.	手制动拉杆右	1		
6	23673-72261	00	Spring,return	回位弹簧	2		
7	23653-72131	00	Plate	导向板	1		
8	23653-72161	00	Stopper,pole lever	顶杆	1		
9	23653-72171	00	Spring,return	回位弹簧	1		
10	23653-72081	00	Strut	手推杆	1		
11	22673-72391	00	Spring	压缩弹簧	1		
12	23653-72151G	00	Lever pole R.H.	调整杠杆右	1		
13	23653-72191	00	Spring seat	压簧座	3		
14	23653-72051	00	Spring	2T 蹄片间回位弹簧	1		
15	23653-72111	00	Compression spring cap	压簧盖	4		
16	23653-72091	00	2T Spring	2T 压簧	4		
17	23653-72121	00	Spring seat	压簧座	1		
18	23653-72101	00	Pull rod	压簧拉杆	4		
19	22673-72231	00	Pin,lever	支承销	1		
20	A01C3-72611	00	Spring shim	弹性垫片	1		
21	24433-70040G	00	Plug	胶塞	1		
22	OC11246-24603	00	Cable	制动钢索总成(右)	1		
22	OC11246-24604	00	Cable	制动钢索总成	1	Japanese brake, 2-2.5t	日本制动器,2-2.5t
23	B0330-08016	00	Bolt	螺栓 M8x16	2	GB5783-86	GB5783-86
24	B5050-00008	00	Washer	垫圈 8	2	GB93-87	GB93-87
25	22673-72031	00	Wheel cylinder ass'y R.H.	制动分泵总成右	1	Include 26,27	包含 26,27
26	22673-72101	00	Cover,dust	制动分泵护罩	2		
27	22673-72081G	01	Cup,piston	分泵皮碗	2		

REF000560L 02 Brake assembly, left

REF000560L 02 制动器总成左

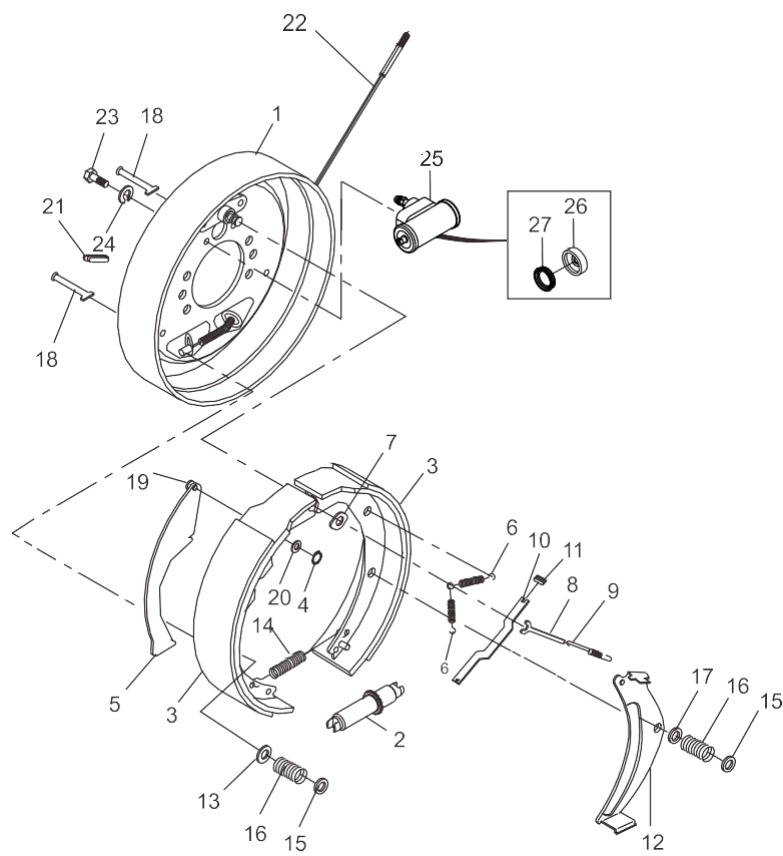

REF000560L 02 Brake assembly, left

REF000560L 02 制动器总成左

序号 No.	零部件代号 Part No.	版本 Edition	名称 Part name		数量 Q'ty	备注 Remark	
1	23653-73011	00	Back plate assembly	制动器底板总成	1		
2	23653-72041	00	Clearance adjuster	间隙调整器	1		
3	23653-73021	01	Brake shoe & friction plate assembly	制动蹄带摩擦片总成	2		
4	A01C3-72621	00	Snap ring,pin axle	杆销挡圈	1		
5	23653-72071G	00	Lever brake L.H.	手制动拉杆左	1		
6	23673-72261	00	Spring,return	回位弹簧	2		
7	23653-72131	00	Plate	导向板	1		
8	23653-72161	00	Stopper,pole lever	顶杆	1		
9	23653-72171	00	Spring,return	回位弹簧	1		
10	23653-72081	00	Strut	手推杆	1		
11	22673-72391	00	Spring	压缩弹簧	1		
12	23653-72151	00	Lever pole L.H.	2T 调整杠杆 (左)	1		
13	23653-72191	00	Spring seat	压簧座	3		
14	23653-72051	00	Spring	2T 蹄片间回位弹簧	1		
15	23653-72111	00	Compression spring cap	压簧盖	4		
16	23653-72091	00	2T Spring	2T 压簧	4		
17	23653-72121	00	Spring seat	压簧座	1		
18	23653-72101	00	Pull rod	压簧拉杆	4		
19	22673-72231	00	Pin,lever	支承销	1		
20	A01C3-72611	00	Spring shim	弹性垫片	1		
21	24433-70040G	00	Plug	胶塞	1		
22	OC11246-14604	00	Cable	制动钢索总成	1	Japanese brake, 2-2.5t	日本制动 器,2-2.5t
22	OC11246-14603	00	Cable	制动钢索总成 (左)	1		
23	B0330-08016	00	Bolt	螺栓 M8x16	2	GB5783-86	GB5783-86
24	B5050-00008	00	Washer	垫圈 8	2	GB93-87	GB93-87
25	22673-72041	00	Wheel cylinder ass'y L.H.	制动分泵 左 1047	1	Include 26,27	包含 26,27
26	22673-72101	00	Cover,dust	制动分泵护罩	2		
27	22673-72081G	01	Cup,piston	分泵皮碗	2		

A1753-00201 00 Reduction assembly

A1753-00201 00 减速器总成

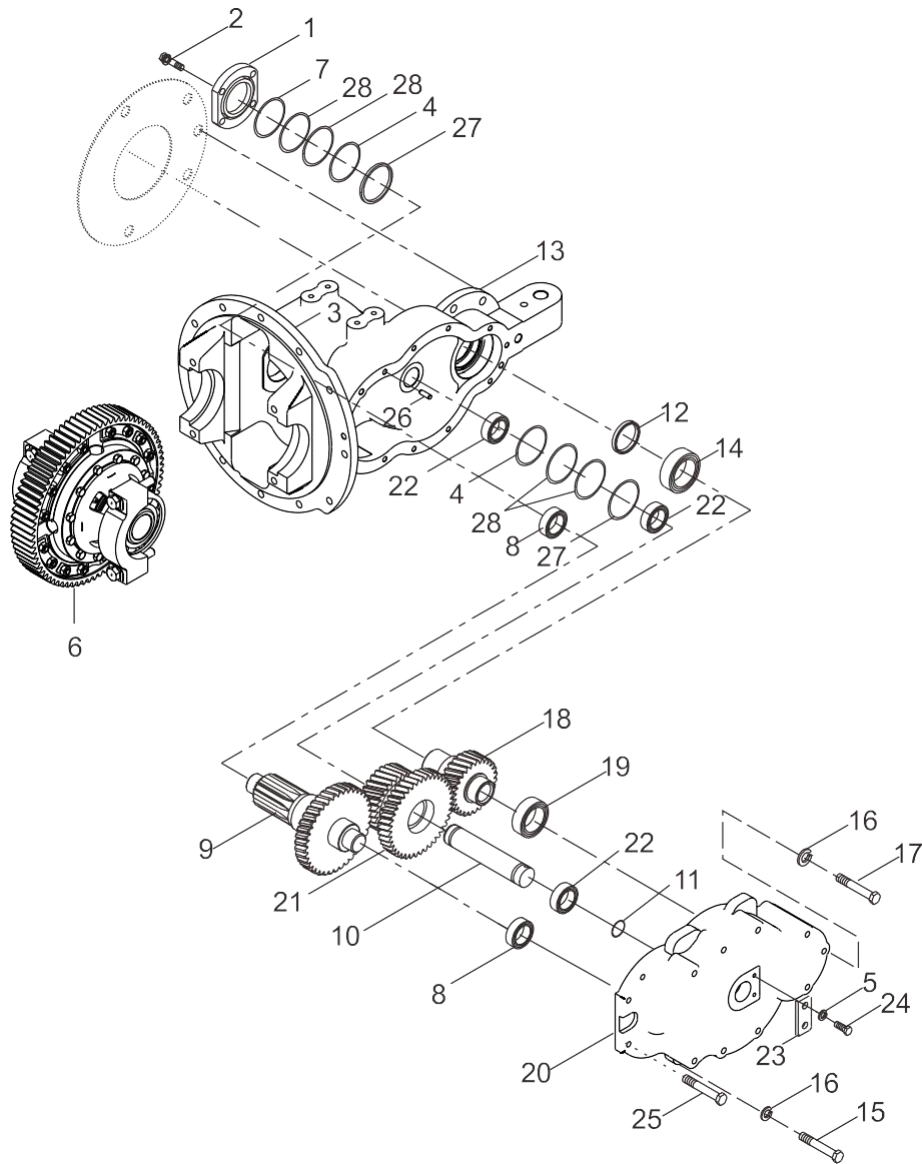

A1753-00201 00 Reduction assembly

A1753-00201 00 减速器总成

序号 No.	零部件代号 Part No.	版本 Edition	名称 Part name		数量 Q'ty	备注 Remark	
1	12003-22051	05	Bearing cover	轴承盖	1		
2	B0330-10025-X1	00	Combined bolt	组合螺栓 M10x25	4	GB/T9074.1 5-88	GB/T9074.1 5-88
3	6TY10-06-05	03	Transmission nameplate	变速箱铭牌	1		
4	15413-22081	02	Washer	垫片	2		
5	B5050-00008	00	Washer	垫圈 8	2	GB93-87	GB93-87
6	A1753-00301	00	Differential unit	差速器总成	1		
7	Z6003-07503	00	O-ring 75x3.1	O形密封圈 75x3.1	1	GB1235-76	GB1235-76
8	Z-32207	00	Bushing	轴承 32207	2	GB/T276-94	GB/T276-94
9	ABL73-02131	00	Gear shaft	齿轴	1		
10	ABL73-02151	01	Shaft	轴	1		
11	Z6003-03503	00	O-ring 35*3.1	O形密封圈 35*3.1	2	GB1235-76	GB1235-76
12	CP-057-2007	00	Skeleton oil seal TC/50*70*12	骨架油封 TC/50*70*12	1	TC/50*70*12	TC/50*70*12
13	ABL73-02141	00	Gearbox housing	变速箱壳体	1		
14	Z-6210	00	Bearing 6210	轴承 6210	1	GB/T276-94	GB/T276-94
15	H2B11-02021	01	Bolt M10x110	螺栓 M10x110	6		
16	B5050-00010	00	Washer	垫圈 10	9	GB93-87	GB93-87
17	A7X53-02191	01	Bolt M10X120	螺栓 M10X120	3		
18	ABL73-02111	00	Shaft,input	输入轴	1		
19	Z-6209	00	Bearing 6209	轴承 6209	1	GB/T276-94	GB/T276-94
20	A7X53-02151	12	Case cover	箱盖	1		
21	ABL73-02121	00	Gear,cluster	双联齿轮	1		
22	Z-6207	00	Bearing	轴承	3	GB/T276-94	GB/T276-94
23	A73J3-02332	02	Lock plate	锁板	1		
24	B0330-08016	00	Bolt	螺栓 M8x16	2	GB5783-86	GB5783-86
25	B0330-10030-X1	00	Combined bolt	组合螺栓 M10x30	2	GB/T9074.1 5-88	GB/T9074.1 5-88
26	B3120-10030	00	Pin B10x30	销 B10x30	1	GB119-86	GB119-86
27	15413-22101	03	Washer	垫片	2		
28	15413-22091	03	Washer	垫片	4		

A1753-00301 00 Differential unit

A1753-00301 00 差速器总成

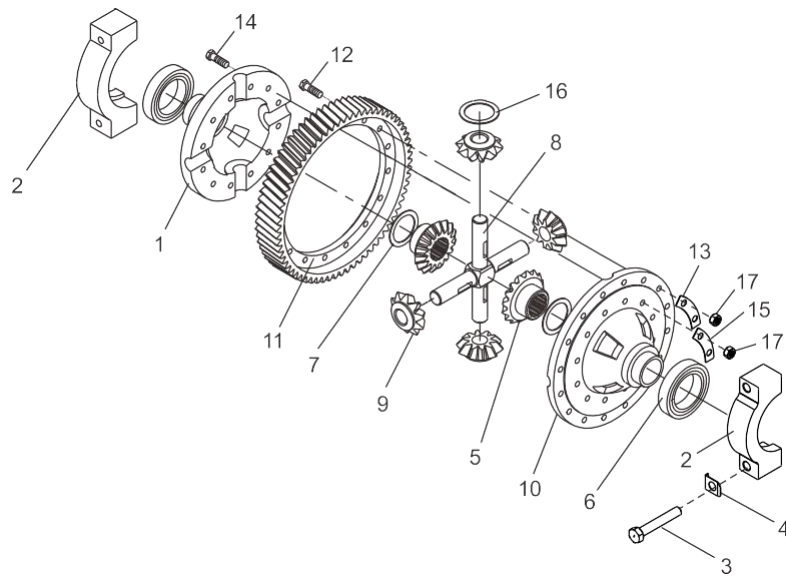

A1753-00301 00 Differential unit

A1753-00301 00 差速器总成

序号 No.	零部件代号 Part No.	版本 Edition	名称 Part name		数量 Q'ty	备注 Remark	
1	14453-52032	07	Case,cross(left)	左差速器壳	1		
2	14453-22031	02	Cap,bushing	轴承座	2		
3	15413-22021	01	Bolt	螺栓	4		
4	14453-52111	03	Lock-plate	锁片	4		
5	H24C3-52001	03	Gear,side	半轴齿轮	2		
6	Z-6213	00	Bearing 6213	轴承 6213	2	GB/T276-94	GB/T276-94
7	14453-52081	02	Mat	半轴齿轮垫	2		
8	14453-52101A	05	Cross axle	十字轴	1		
9	16113-52112	03	Planet gear	行星齿轮	4		
10	14453-52022	11	Case,cross(right)	右差速器壳	1		
11	ABL73-02101	00	Gear ring	齿圈	1		
12	14453-52051	03	Bolt	螺栓	16		
13	10113-50141	02	Lock-plate	锁片	8		
14	14453-52041	01	Bolt	螺栓	12		
15	14453-52061	02	Lock-plate	锁片	6		
16	16113-52121	02	Washer,thrust	止推垫圈	4		
17	B4223-00010	00	Nut	螺母 M10x1.25	28	GB6171-86	GB6171-86

A1753-00011 02 Drive axle assembly

A1753-00011 02 驱动桥总成(双胎人力制动)

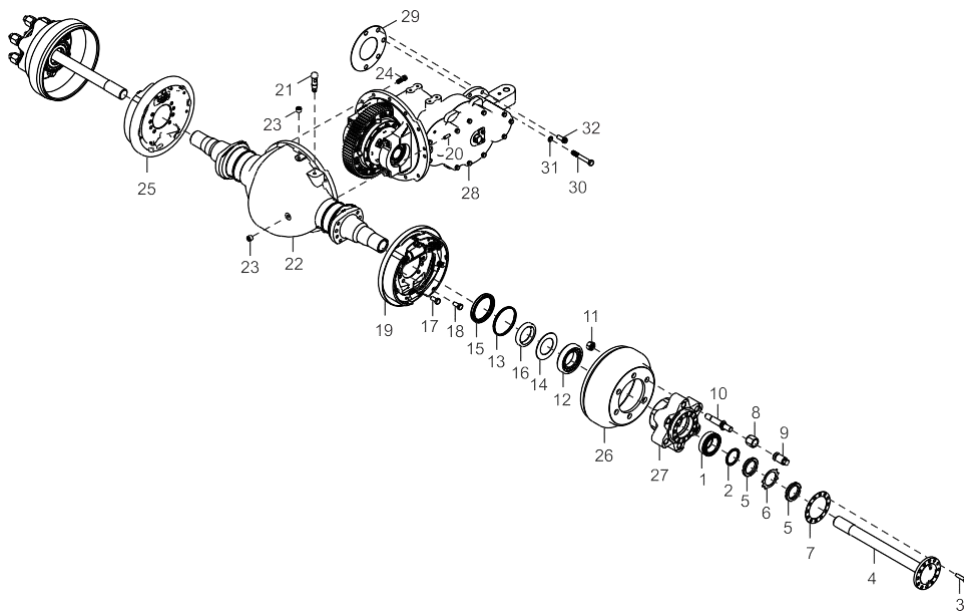

A1753-00011 02 Drive axle assembly

A1753-00011 02 驱动桥总成(双胎人力制动)

序号 No.	零部件代号 Part No.	版本 Edition	名称 Part name		数量 Q'ty	备注 Remark	
1	23453-02071G	01	Bearing	轴承	2		
2	23453-02091	01	Shim	垫	2		
3	24453-02061	03	Bolt	螺栓	24		
4	H24C3-02001	02	Half,shaft	半轴	2		
5	B4732-00060	00	Nut M60x2	螺母 M60x2	4	GB810-88	GB810-88
6	B5512-00060	00	Washer 60	垫圈 60	2	GB858-88	GB858-88
7	A22A3-02031	05	Packing	半轴垫	2		
8	24463-00060G2	00	Nut	双胎球螺母	12		
9	24463-00050G2	00	Nut	柱螺母	12		
10	24353-72001G2	01	Bolt	螺栓	12		
11	B4223-00020	00	Nut	螺母 M20x1.5	12	GB6171-86	GB6171-86
12	Z-30214	00	Bearing	轴承 30214	2	GB/T 297-94	GB/T 297-94
13	22493-00020G	01	Washer	备用垫	2		
14	22493-00030G	02	Retainer	挡油圈	2		
15	Z6311-10014	00	Skeleton oil seal	骨架油封	2	GB9877.1-88	GB9877.1-88
16	24453-02121G	05	Snap ring	油封挡圈	2		
17	A22A3-02051	03	Bolt	螺栓	12		
18	25953-72001	03	Bolt	螺栓	4		
19	REF000560L	02	Brake assembly, left	制动器总成左	1		
20	B3120-10030	00	Pin B10x30	销 B10x30	1	GB119-86	GB119-86
21	22253-02063C	01	Breather plug	透气塞	1		
22	A73E3-02201	08	Housing,axle	驱动桥壳	1		
23	22193-03001	02	Plug	堵塞	3		
24	B0530-12040-X1	00	Combined bolt M12x1.25x40	组合螺栓 M12x1.25x40	12	GB5786,GB93	GB5786,GB93
25	REF000560R	02	Brake assembly, right	制动器总成右	1		
26	22673-02031G2	01	Drum,brake	制动毂	2		
27	A22A3-02071	00	Hub,wheel	轮毂	2		
28	A1753-00201	00	Reduction assembly	减速器总成	1		
29	A7X53-02171	04	Gasket	纸垫	1		
30	B0430-14090	00	Bolt M14x1.5x90	螺栓 M14x1.5x90	1	GB5785-86	GB5785-86
31	B5050-00014	00	Washer	垫圈 14	1	GB93-87	GB93-87

A1753-00011 02 Drive axle assembly

A1753-00011 02 驱动桥总成(双胎人力制动)

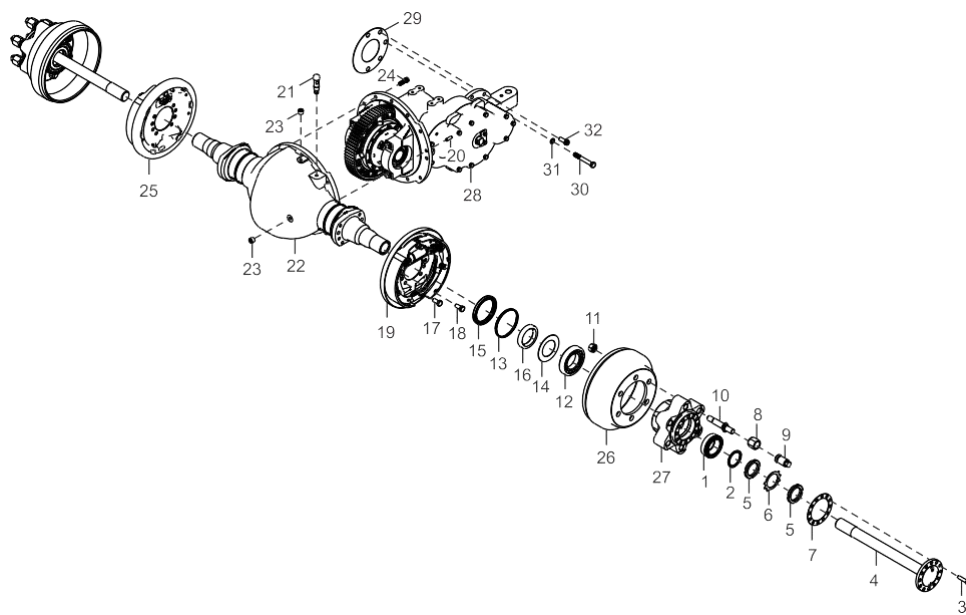

REF000560L 02 Brake assembly, left

REF000560L 02 制动器总成左

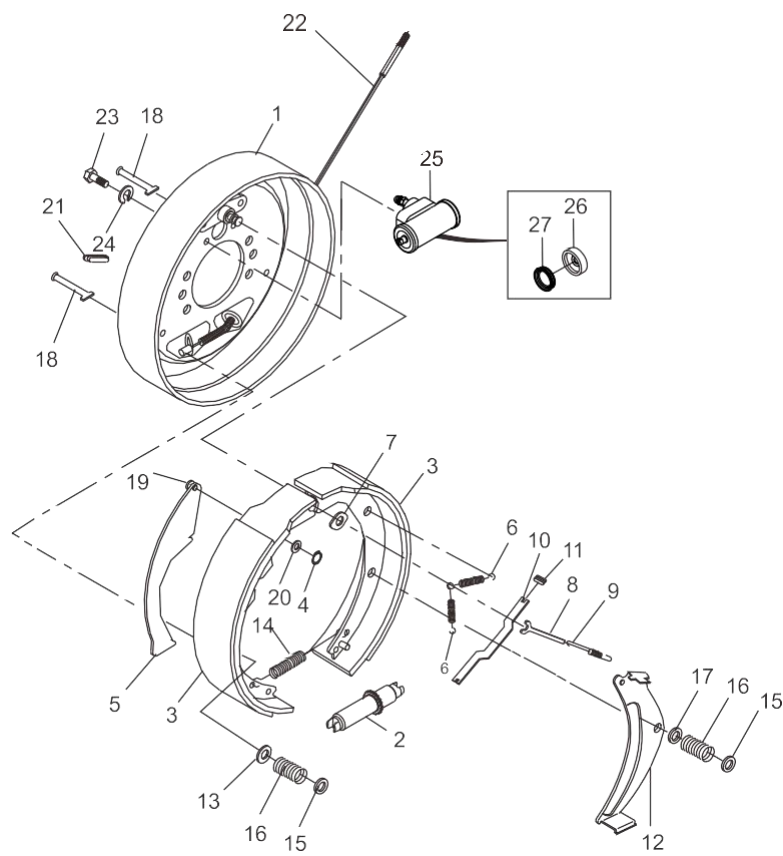

REF000560L 02 Brake assembly, left

REF000560L 02 制动器总成左

序号 No.	零部件代号 Part No.	版本 Edition	名称 Part name		数量 Q'ty	备注 Remark	
1	23653-73011	00	Back plate assembly	制动器底板总成	1		
2	23653-72041	00	Clearance adjuster	间隙调整器	1		
3	23653-73021	01	Brake shoe & friction plate assembly	制动蹄带摩擦片总成	2		
4	A01C3-72621	00	Snap ring,pin axle	杆销挡圈	1		
5	23653-72071G	00	Lever brake L.H.	手制动拉杆左	1		
6	23673-72261	00	Spring,return	回位弹簧	2		
7	23653-72131	00	Plate	导向板	1		
8	23653-72161	00	Stopper,pole lever	顶杆	1		
9	23653-72171	00	Spring,return	回位弹簧	1		
10	23653-72081	00	Strut	手推杆	1		
11	22673-72391	00	Spring	压缩弹簧	1		
12	23653-72151	00	Lever pole L.H.	2T 调整杠杆 (左)	1		
13	23653-72191	00	Spring seat	压簧座	3		
14	23653-72051	00	Spring	2T 蹄片间回位弹簧	1		
15	23653-72111	00	Compression spring cap	压簧盖	4		
16	23653-72091	00	2T Spring	2T 压簧	4		
17	23653-72121	00	Spring seat	压簧座	1		
18	23653-72101	00	Pull rod	压簧拉杆	4		
19	22673-72231	00	Pin,lever	支承销	1		
20	A01C3-72611	00	Spring shim	弹性垫片	1		
21	24433-70040G	00	Plug	胶塞	1		
22	OC11246-14604	00	Cable	制动钢索总成	1	Japanese brake, 2-2.5t	日本制动器,2-2.5t
22	OC11246-14603	00	Cable	制动钢索总成 (左)	1		
23	B0330-08016	00	Bolt	螺栓 M8x16	2	GB5783-86	GB5783-86
24	B5050-00008	00	Washer	垫圈 8	2	GB93-87	GB93-87
25	22673-72041	00	Wheel cylinder ass'y L.H.	制动分泵 左 1047	1	Include 26,27	包含 26,27
26	22673-72101	00	Cover,dust	制动分泵护罩	2		
27	22673-72081G	01	Cup,piston	分泵皮碗	2		

REF000560R 02 Brake assembly, right

REF000560R 02 制动器总成右

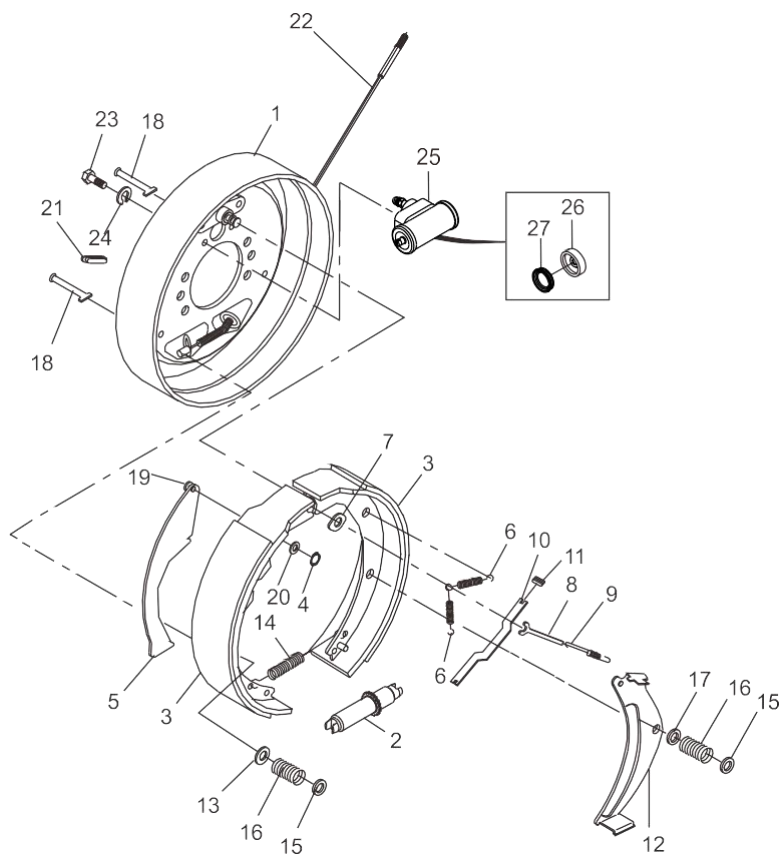

REF000560R 02 Brake assembly, right

REF000560R 02 制动器总成右

序号 No.	零部件代号 Part No.	版本 Edition	名称 Part name		数量 Q'ty	备注 Remark	
1	23653-73111	00	Back plate ass'y R.H.	制动器底板总成右	1		
2	23653-72441	00	Adjust R.H.	间隙调整器右	1		
3	23653-73021	01	Brake shoe & friction plate assembly	制动蹄带摩擦片总成	2		
4	A01C3-72621	00	Snap ring,pin axle	杆销挡圈	1		
5	23653-72071A	00	Lever brake R.H.	手制动拉杆右	1		
6	23673-72261	00	Spring,return	回位弹簧	2		
7	23653-72131	00	Plate	导向板	1		
8	23653-72161	00	Stopper,pole lever	顶杆	1		
9	23653-72171	00	Spring,return	回位弹簧	1		
10	23653-72081	00	Strut	手推杆	1		
11	22673-72391	00	Spring	压缩弹簧	1		
12	23653-72151G	00	Lever pole R.H.	调整杠杆右	1		
13	23653-72191	00	Spring seat	压簧座	3		
14	23653-72051	00	Spring	2T 蹄片间回位弹簧	1		
15	23653-72111	00	Compression spring cap	压簧盖	4		
16	23653-72091	00	2T Spring	2T 压簧	4		
17	23653-72121	00	Spring seat	压簧座	1		
18	23653-72101	00	Pull rod	压簧拉杆	4		
19	22673-72231	00	Pin,lever	支承销	1		
20	A01C3-72611	00	Spring shim	弹性垫片	1		
21	24433-70040G	00	Plug	胶塞	1		
22	OC11246-24603	00	Cable	制动钢索总成(右)	1		
22	OC11246-24604	00	Cable	制动钢索总成	1	Japanese brake, 2-2.5t	日本制动器,2-2.5t
23	B0330-08016	00	Bolt	螺栓 M8x16	2	GB5783-86	GB5783-86
24	B5050-00008	00	Washer	垫圈 8	2	GB93-87	GB93-87
25	22673-72031	00	Wheel cylinder ass'y R.H.	制动分泵总成右	1	Include 26,27	包含 26,27
26	22673-72101	00	Cover,dust	制动分泵护罩	2		
27	22673-72081G	01	Cup,piston	分泵皮碗	2		

A1753-00201 00 Reduction assembly

A1753-00201 00 减速器总成

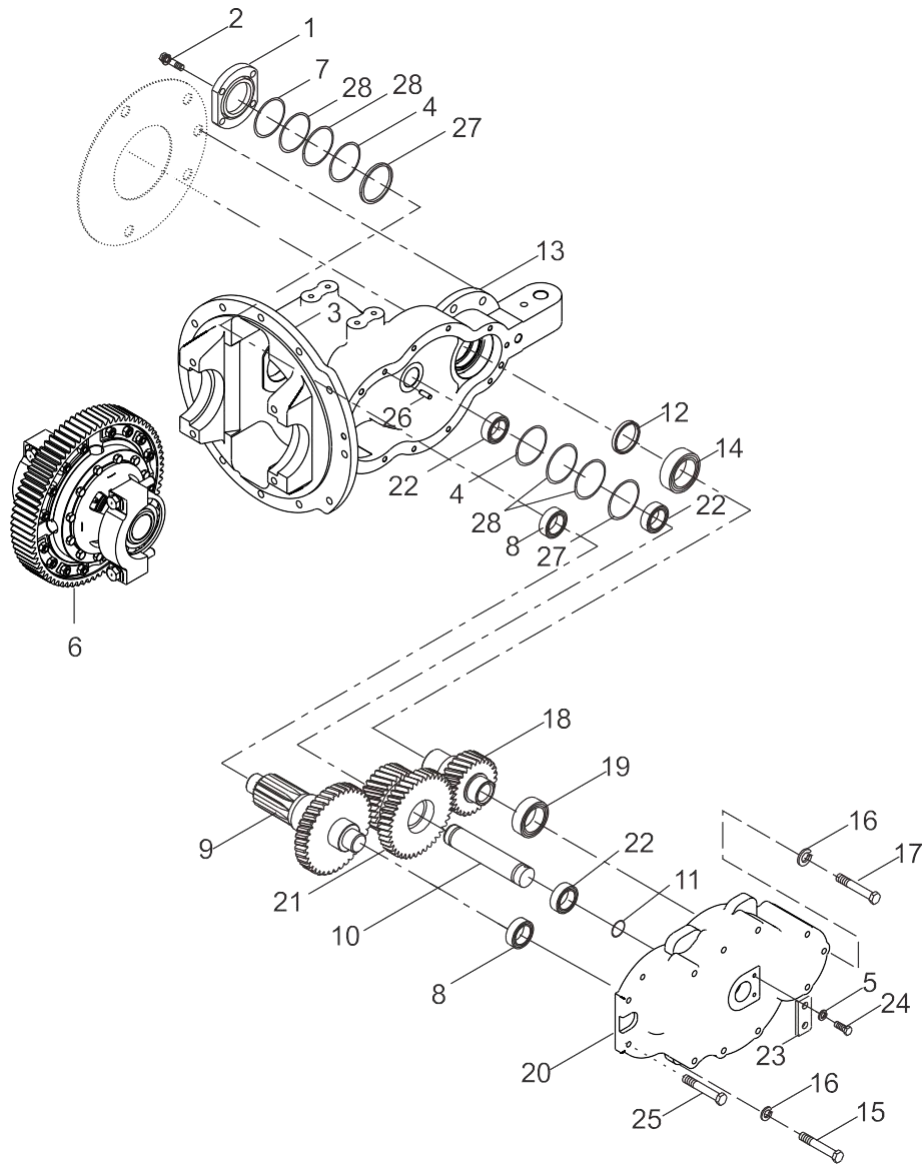

A1753-00201 00 Reduction assembly

A1753-00201 00 减速器总成

序号 No.	零部件代号 Part No.	版本 Edition	名称 Part name		数量 Q'ty	备注 Remark	
1	12003-22051	05	Bearing cover	轴承盖	1		
2	B0330-10025-X1	00	Combined bolt	组合螺栓 M10x25	4	GB/T9074.1 5-88	GB/T9074.1 5-88
3	6TY10-06-05	03	Transmission nameplate	变速箱铭牌	1		
4	15413-22081	02	Washer	垫片	2		
5	B5050-00008	00	Washer	垫圈 8	2	GB93-87	GB93-87
6	A1753-00301	00	Differential unit	差速器总成	1		
7	Z6003-07503	00	O-ring 75x3.1	O形密封圈 75x3.1	1	GB1235-76	GB1235-76
8	Z-32207	00	Bushing	轴承 32207	2	GB/T276-94	GB/T276-94
9	ABL73-02131	00	Gear shaft	齿轴	1		
10	ABL73-02151	01	Shaft	轴	1		
11	Z6003-03503	00	O-ring 35*3.1	O形密封圈 35*3.1	2	GB1235-76	GB1235-76
12	CP-057-2007	00	Skeleton oil seal TC/50*70*12	骨架油封 TC/50*70*12	1	TC/50*70*12	TC/50*70*12
13	ABL73-02141	00	Gearbox housing	变速箱壳体	1		
14	Z-6210	00	Bearing 6210	轴承 6210	1	GB/T276-94	GB/T276-94
15	H2B11-02021	01	Bolt M10x110	螺栓 M10x110	6		
16	B5050-00010	00	Washer	垫圈 10	9	GB93-87	GB93-87
17	A7X53-02191	01	Bolt M10X120	螺栓 M10X120	3		
18	ABL73-02111	00	Shaft,input	输入轴	1		
19	Z-6209	00	Bearing 6209	轴承 6209	1	GB/T276-94	GB/T276-94
20	A7X53-02151	12	Case cover	箱盖	1		
21	ABL73-02121	00	Gear,cluster	双联齿轮	1		
22	Z-6207	00	Bearing	轴承	3	GB/T276-94	GB/T276-94
23	A73J3-02332	02	Lock plate	锁板	1		
24	B0330-08016	00	Bolt	螺栓 M8x16	2	GB5783-86	GB5783-86
25	B0330-10030-X1	00	Combined bolt	组合螺栓 M10x30	2	GB/T9074.1 5-88	GB/T9074.1 5-88
26	B3120-10030	00	Pin B10x30	销 B10x30	1	GB119-86	GB119-86
27	15413-22101	03	Washer	垫片	2		
28	15413-22091	03	Washer	垫片	4		

A1753-00301 00 Differential unit

A1753-00301 00 差速器总成

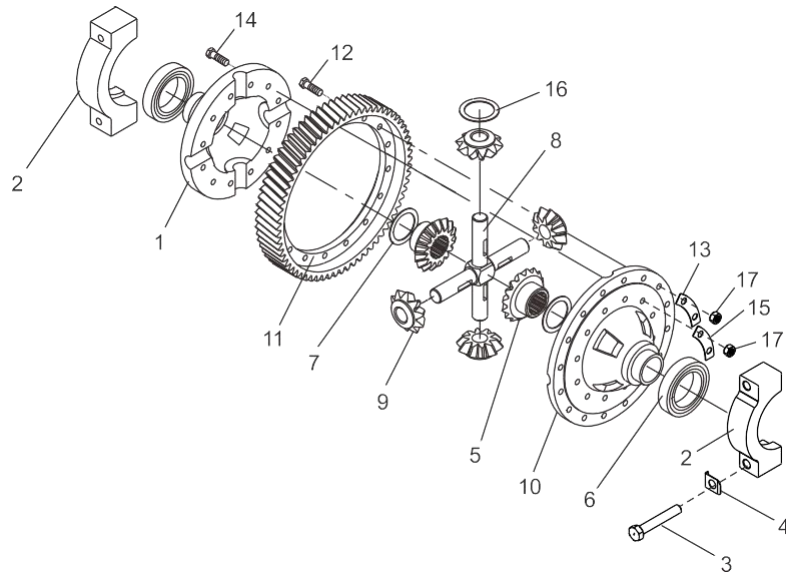

A1753-00301 00 Differential unit

A1753-00301 00 差速器总成

序号 No.	零部件代号 Part No.	版本 Edition	名称 Part name		数量 Q'ty	备注 Remark	
1	14453-52032	07	Case,cross(left)	左差速器壳	1		
2	14453-22031	02	Cap,bushing	轴承座	2		
3	15413-22021	01	Bolt	螺栓	4		
4	14453-52111	03	Lock-plate	锁片	4		
5	H24C3-52001	03	Gear,side	半轴齿轮	2		
6	Z-6213	00	Bearing 6213	轴承 6213	2	GB/T276-94	GB/T276-94
7	14453-52081	02	Mat	半轴齿轮垫	2		
8	14453-52101A	05	Cross axle	十字轴	1		
9	16113-52112	03	Planet gear	行星齿轮	4		
10	14453-52022	11	Case,cross(right)	右差速器壳	1		
11	ABL73-02101	00	Gear ring	齿圈	1		
12	14453-52051	03	Bolt	螺栓	16		
13	10113-50141	02	Lock-plate	锁片	8		
14	14453-52041	01	Bolt	螺栓	12		
15	14453-52061	02	Lock-plate	锁片	6		
16	16113-52121	02	Washer,thrust	止推垫圈	4		
17	B4223-00010	00	Nut	螺母 M10x1.25	28	GB6171-86	GB6171-86

HRA1754401 01 Front weel ass'y

HRA1754401 01 车轮总成

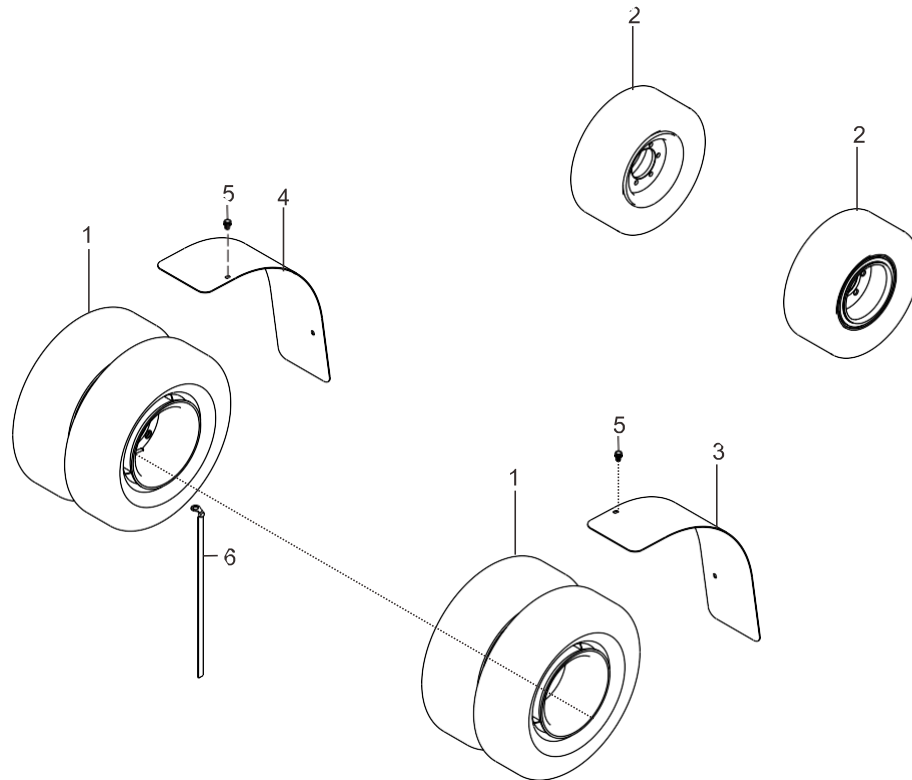

HRA1754404 00 Front wheel (double tyre)

HRA1754404 00 前轮总成 (双胎)

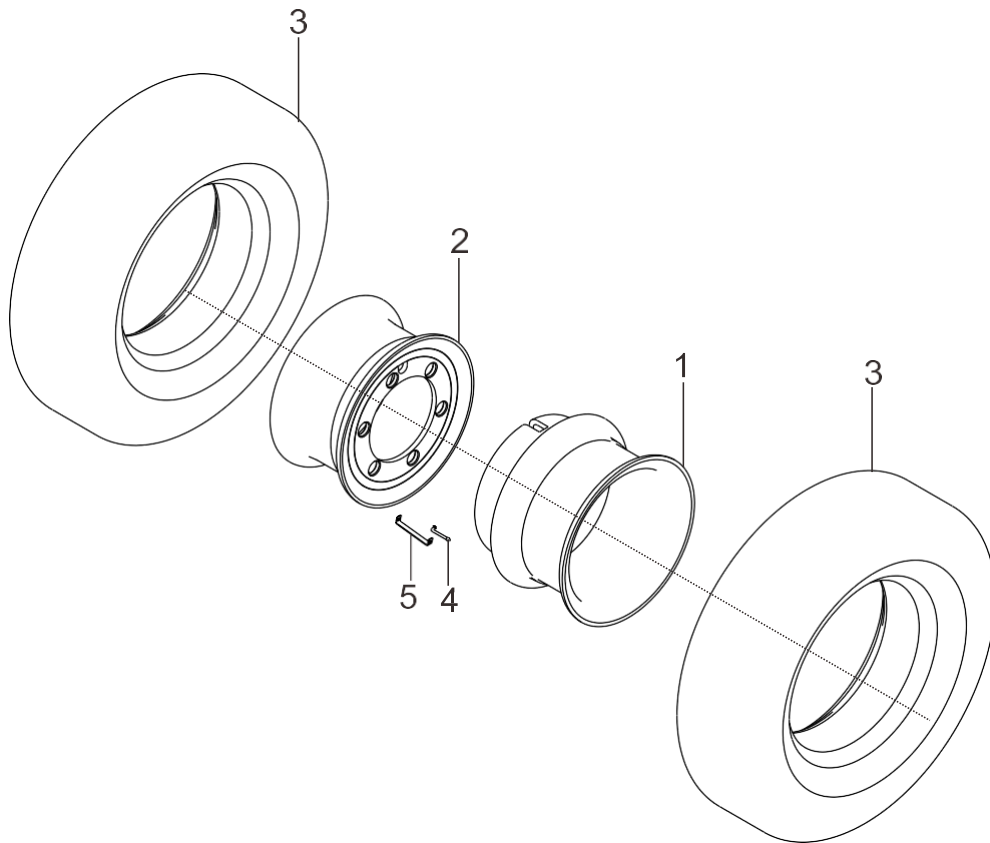

HRA1754404 00 Front wheel (double tyre)

HRA1754404 00 前轮总成 (双胎)

序号 No.	零部件代号 Part No.	版本 Edition	名称 Part name		数量 Q'ty	备注 Remark	
1	22493-01000G2	01	Rim assembly	内轮辋总成	1		
2	22493-02001G2	01	Rim assembly	外轮辋总成	1		
3	Z3350-70012B	00	No-marking tyre	无痕迹轮胎 7.00-12	2	Matching ordinary pattern no trace solid tyre	选配普通花纹无痕迹实心胎
3	Z3350-70012	00	Tire 7.00-12	实心轮胎 7.00-12	2	Matching, ordinary pattern solid tyre	选配, 普通花纹实心胎
3	Z3054-70012	00	Tire	轮胎 7.00-12-12PR	2	Matching, ordinary pattern pneumatic tyre	选配, 普通花纹充气胎
3	Z3300-70012B	00	No-marking solid tyre	无痕迹实心胎	2		
3	Z3300-70012	00	Solid tyre	实心胎 (2-2.5t 前轮)	2	Matching, large pattern solid tyre	选配, 大花纹实心胎
3	Z3005-70012	00	Pneumatic tyre	充气胎, 7.00-12-14PR	2	Standard, large pattern pneumatic tyre	标配, 大花纹充气胎
4	25783-02240	02	Pipe	充气接管	1		
5	24493-04000G	00	Support	支架	1		

HRA1754402 00 Front wheel (single tyre)

HRA1754402 00 前轮总成 (单胎)

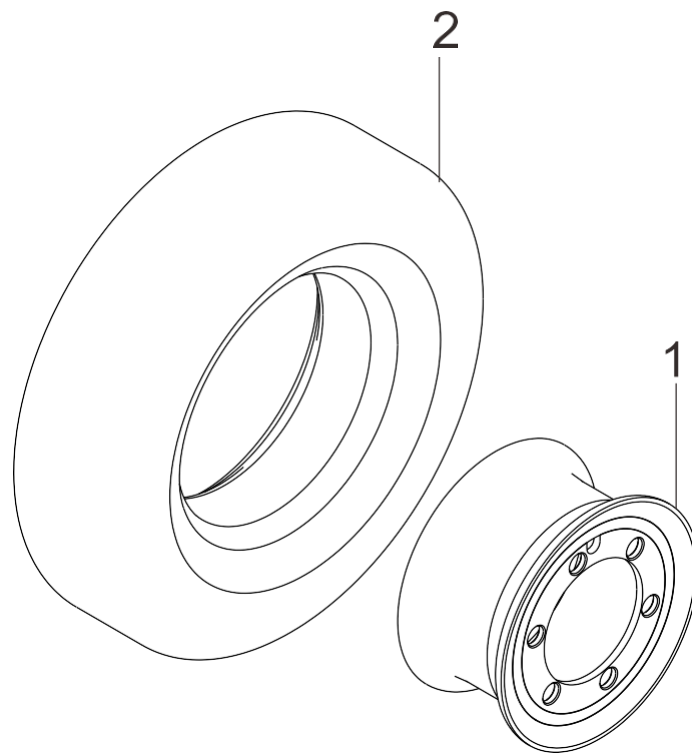

HRA1754402 00 Front wheel (single tyre)							
HRA1754402 00 前轮总成 (单胎)							
序号 No.	零部件代号 Part No.	版本 Edition	名称 Part name		数量 Q'ty	备注 Remark	
1	H9BA3-00501	01	Rim ass'y	轮辋总成(5.00Sx12DT)	1		
2	Z3350-70012B	00	No-marking tyre	无痕迹轮胎 7.00-12	1		
2	Z3350-70012	00	Tire 7.00-12	实心轮胎 7.00-12	1		
2	Z3054-70012	00	Tire	轮胎 7.00-12-12PR	1	GB/T2982-2001	GB/T2982-2001
2	Z3300-70012B	00	No-marking solid tyre	无痕迹实心胎	1		
2	Z3300-70012	00	Solid tyre	实心胎 (2-2.5t 前轮)	1		
2	Z3005-70012	00	Pneumatic tire	充气胎, 7.00-12-14PR	1	Standard, large pattern pneumatic tire	标配, 大花纹充气胎

HRA1754403 00 Rear wheel

HRA1754403 00 后轮总成

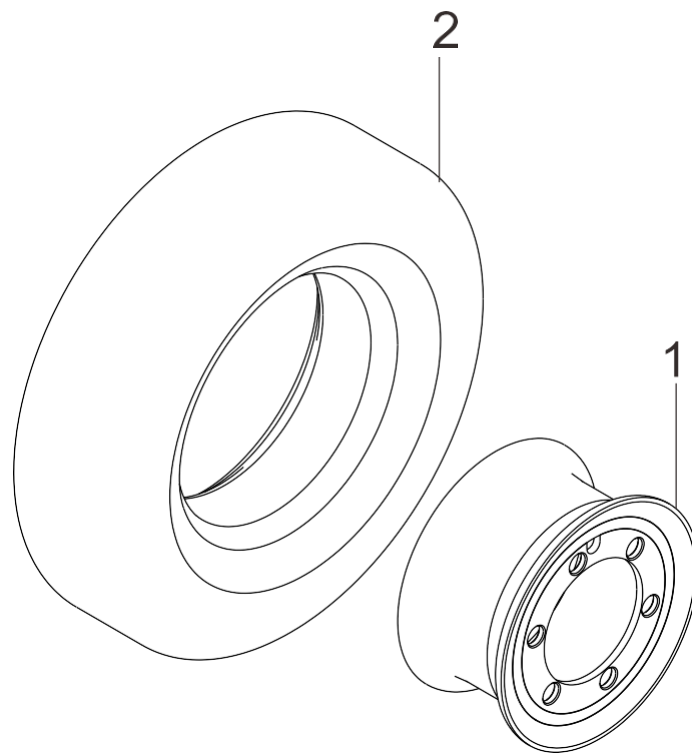

HRA1754403 00 Rear wheel

HRA1754403 00 后轮总成

序号 No.	零部件代号 Part No.	版本 Edition	名称 Part name		数量 Q'ty	备注 Remark	
1	A79M4-40301D	00	Rim ass'y	轮辋总成	1		
2	Z3350-70008B	00	Tyre	实心轮胎 18x7-8	1	GB/T10823-1996	GB/T10823-1996
2	Z3350-70008	00	Tyre	实心轮胎 18x7(2-2.5 后轮	1	GB/T10823-1996	GB/T10823-1996
2	Z3055-70008	00	Tyre	正新充气轮胎 18x7-8-14PR	1	GB/T2982-2001	GB/T2982-2001
2	Z3300-70008B	00	Tyre	实心轮胎 18x7-8	1	GB/T10823-1996	GB/T10823-1996
2	Z3300-70008	00	Solid tyre	实心胎	1	GB/T10823-1996	GB/T10823-1996
2	Z3005-70008	00	Tyre 18x7-8-14PR	轮胎 18x7-8-14PR	1	GB/T2982-2001	GB/T2982-2001

HRA1754101 00 Steering mounting system

HRA1754101 00 转向安装系统

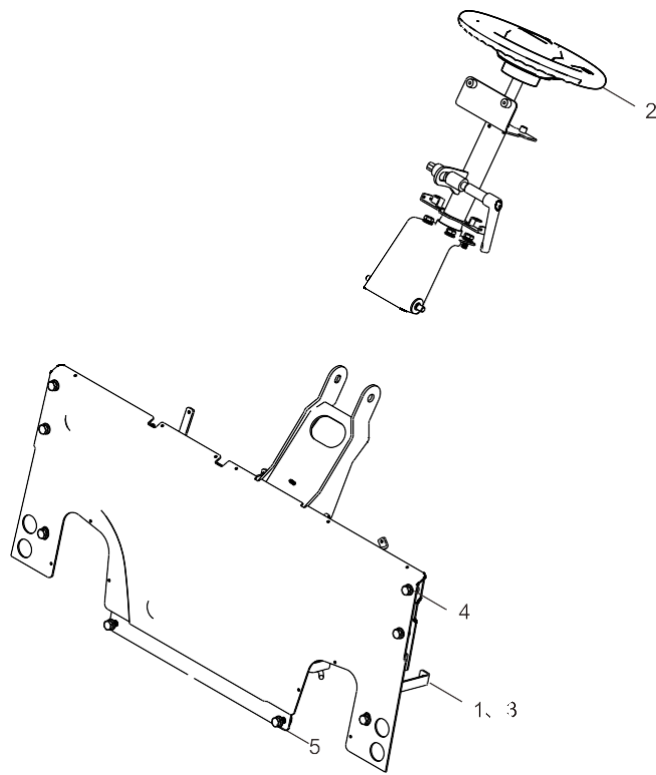

HRA1754101 00 Steering mounting system

HRA1754101 00 转向安装系统

序号 No.	零部件代号 Part No.	版本 Edition	名称 Part name		数量 Q'ty	备注 Remark	
1	A1754-10101	00	Instrument stand	仪表架总成	1	Include 3-5	包含 3-5
1	A1754-10101NF	00	Instrument stand	仪表架总成	1		包含 3-5,装 暖风机
2	HRACS74101	00	Steering system	转向系统	1		
3	A1754-10201	01	Instrument frame	仪表架焊接	1		
3	A1754-10201NF	01	Instrument frame	仪表架焊接	1	With heater	装暖风机
4	B0330-10030-X	00	Combined bolt	组合螺栓 M10x30	6	GB/T9074.1 7-88	GB/T9074.1 7-88
5	B0330-08020-D	00	Combined bolt	组合螺栓 M8x20	2	GB5783,GB 93,GB96	GB5783,GB 93,GB96

HRACS74101 00 Steering system

HRACS74101 00 转向系统

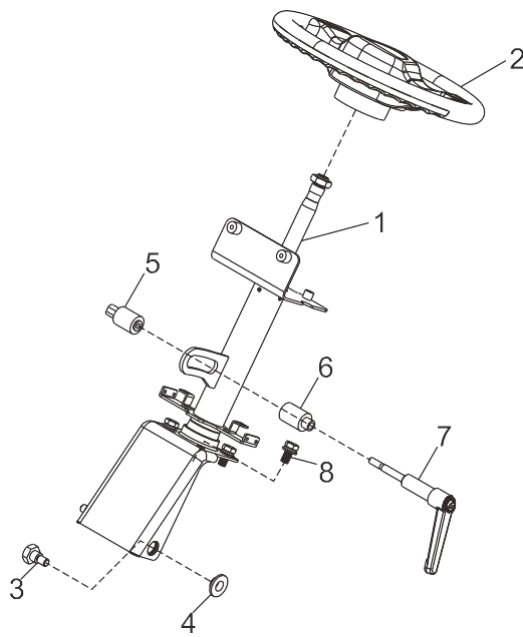

HRACS74101 00 Steering system

HRACS74101 00 转向系统

序号 No.	零部件代号 Part No.	版本 Edition	名称 Part name		数量 Q'ty	备注 Remark	
1	ABG74-10501	00	Column	转向管柱总成	1		
2	ABG74-10601	00	Steering wheel	方向盘	1		
2	ABG74-10701	00	Steering wheel	方向盘(无球形把手)	1	No knob	无球形把手
2	ABG74-10801	00	Steering wheel	方向盘(无合力字样)	1	Neutral Packing	中性包装
3	G27Z4-12001	01	Bolt	螺栓	2		
4	G27Z4-12011	01	Washer	垫圈	2		
5	KM914-12011	04	Nut	螺母	1		
6	KM914-12031	02	Spacer	套管	1		
7	H2MD4-10301	01	Lever	手柄总成	1		
8	B0330-10020-X	00	Combined bolt	组合螺栓 M10x20	4	GB/T 9074.17-88	GB/T 9074.17-88

ABG74-10501 00 Column

ABG74-10501 00 转向管柱总成

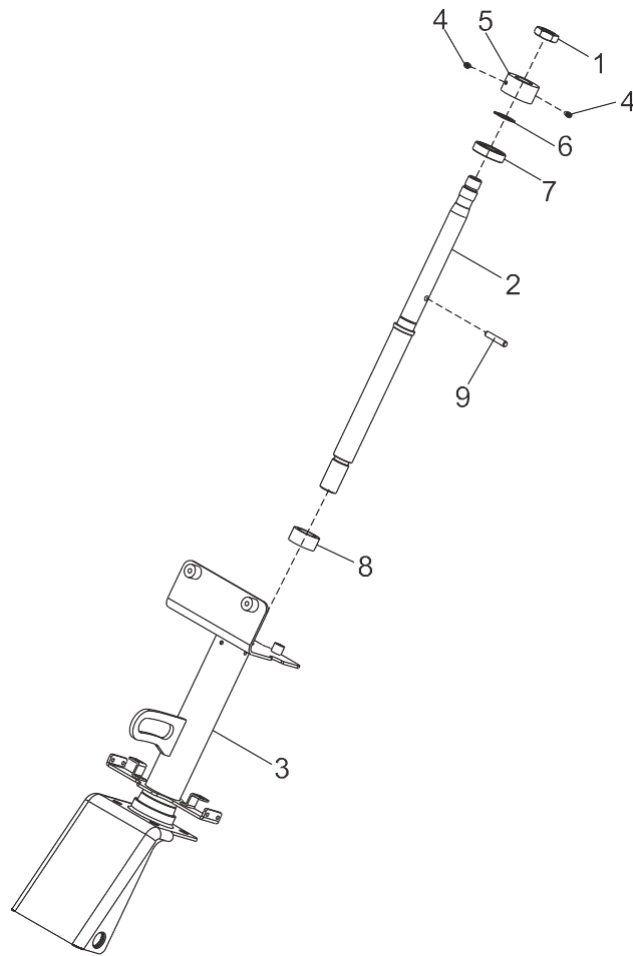

H2MD4-10301 01 Lever

H2MD4-10301 01 手柄总成

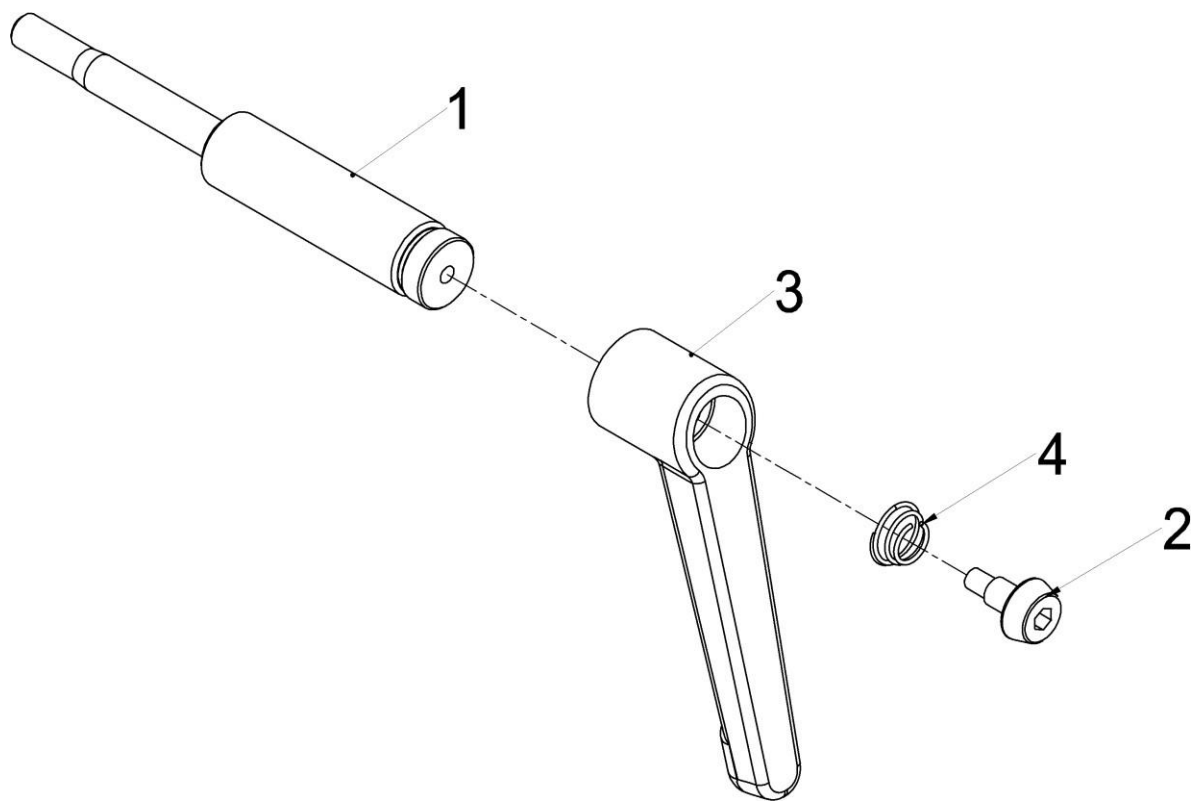

ABG74-30001B 00 Steering axle

ABG74-30001B 00 横置油缸转向桥

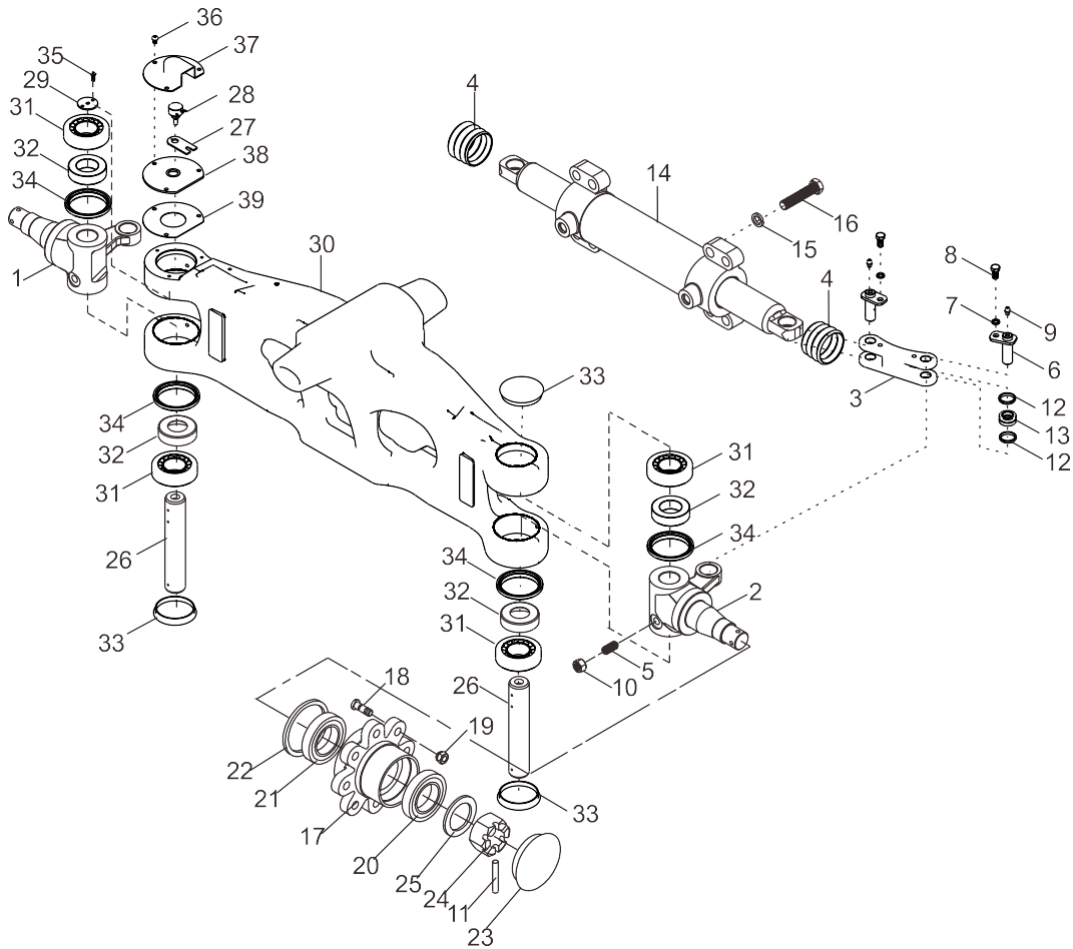

ABG74-30001B 00 Steering axle

ABG74-30001B 00 横置油缸转向桥

序号 No.	零部件代号 Part No.	版本 Edition	名称 Part name		数量 Q'ty	备注 Remark	
1	ABG74-31021	01	Pin,king	右转向节	1	HRABG741 01	HRABG741 01
2	ABG74-31011	01	Pin,king	左转向节	1	HRABG741 01	HRABG741 01
3	ABG74-31041	00	Connecting rod	连杆/白锌	2		
4	A7V94-30708CHT	00	Sleeve	中护套	2		
5	G27Z4-32011	00	Pin M12x30	紧定螺钉 M12x30	2		
6	A7V94-32021	00	Link pin	连杆销	4		
7	B5050-00008	00	Washer	垫圈 8	4	GB93-87	GB93-87
8	B0530-08016	00	Bolt M8x1x16	螺栓 M8x1x16	4	GB5786-86	GB5786-86
9	Q700B06	01	Fitting	直通式滑油嘴	8	ZBT33001.1 -88	ZBT33001.1 -88
10	B4123-00012	00	Nut	螺母 M12	2	GB6170-86	GB6170-86
11	B3010-6P360	00	Pin 6.3x60	销 6.3x60	2	GB91-86	GB91-86
12	H24C4-12003	02	Dushing	衬套	6		
13	H24C4-32061	02	Bearing	关节轴承	4		
14	AL734-30301	01	Steering cylinder	转向油缸总成	1		
15	B5050-00016	00	Washer	垫圈 16	8	GB93-87	GB93-87
16	B0632-16060	00	Bolt M16x60	螺栓 M16x60	8	GB27-88	GB27-88
17	A7BJ4-32151	00	Hub,wheel	轮毂	2		
18	23654-32041	02	Bolt	轮毂螺栓	16		
19	23654-34051	05	Nut	轮毂螺母	16		
20	Z-30207	00	Bearing 30207	轴承 30207	2	GB/T297-94	GB/T297-94
21	A7BJ4-32501	00	Bearing Z-32210	轴承 Z-32210	2		
22	Z6301-07523	00	U-ring	U形密封圈 75x100x10D	2	GB9877.1- 88	GB9877.1- 88
23	A21B4-32231	01	Hub cover	轮毂盖	2		
24	A21B4-32311	00	Nut M30x2	螺母 M30x2	2		
25	B5310-00030	00	Washer 30	垫圈 30	2	GB97.1-85	GB97.1-85
26	ABG74-31101	00	King Pin,steering knuckle	转向节主销	2	For potentiomet er	带电位器用
27	A61K2-42041	00	Potentiometer localizer	转角电位器定位片	2		
28	A61K2-41101	02	Angle locator	转角定位器	2		
29	ABG74-31081	00	Plate	电位计定位盖	2		
30	ABG74-31111B	00	Axle assembly	转向桥体	1	For double potentiomet er	装双电位器 用

ABG74-30001B 00 Steering axle

ABG74-30001B 00 横置油缸转向桥

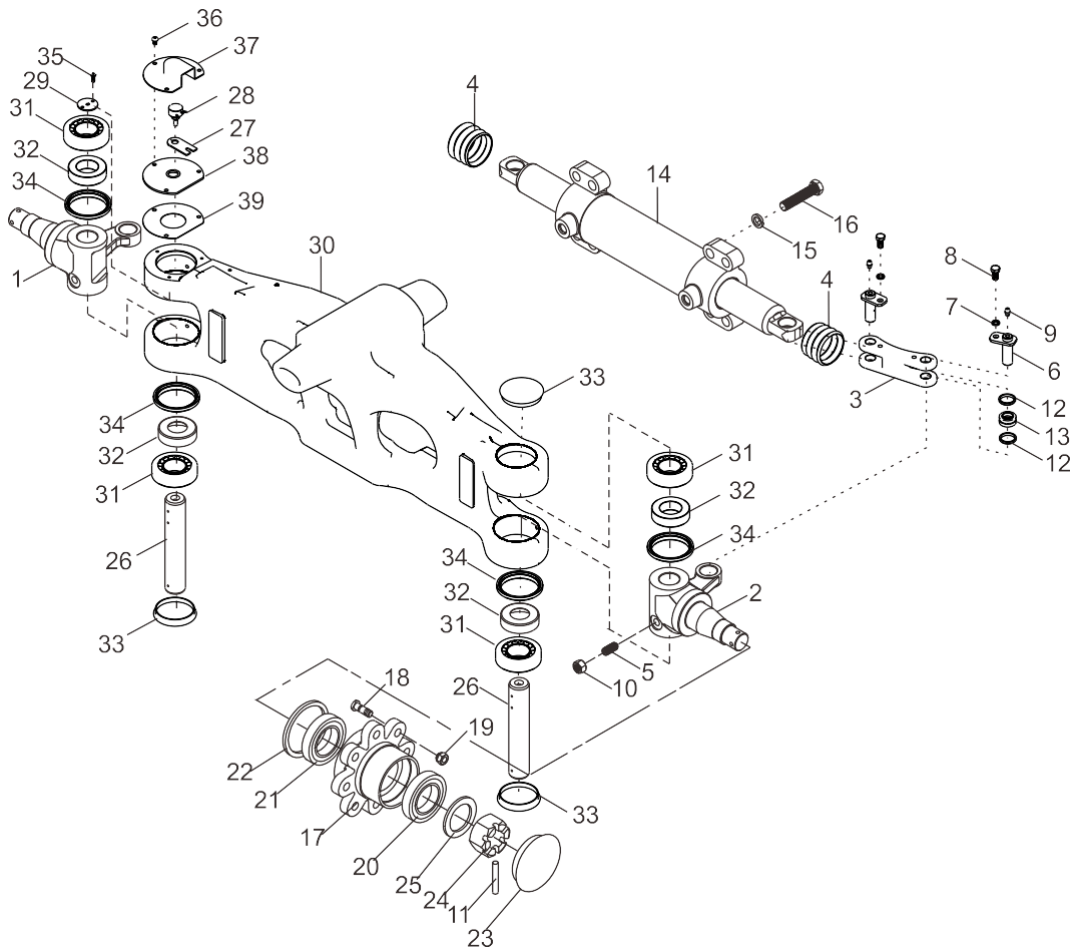

AL734-30301 01 Steering cylinder

AL734-30301 01 转向油缸总成

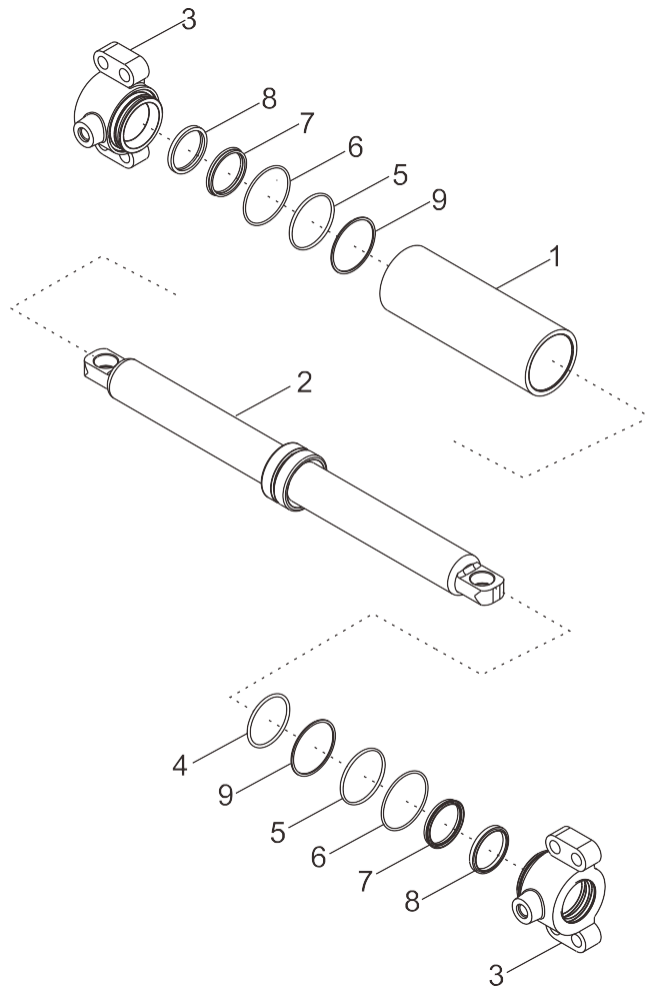

ABG74-30001 05 Steering axle

ABG74-30001 05 横置油缸转向桥

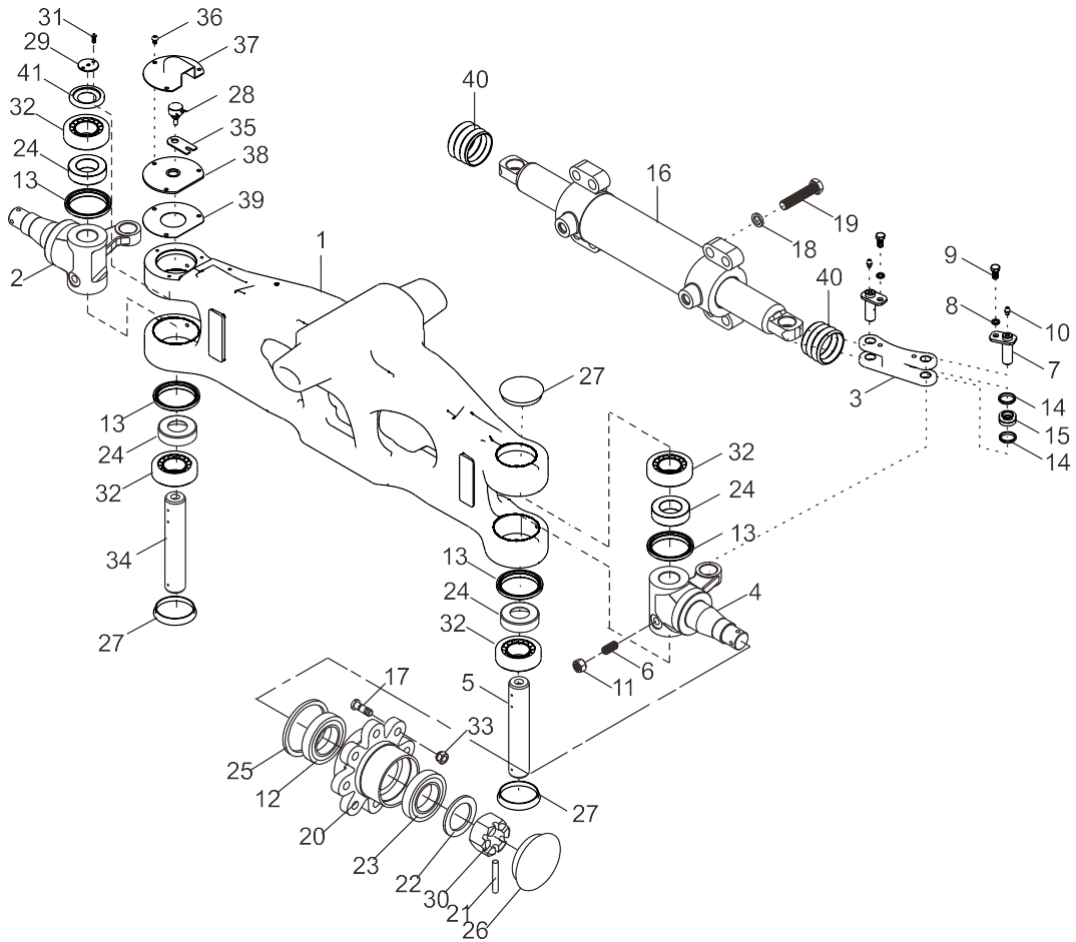

ABG74-30001 05 Steering axle

ABG74-30001 05 横置油缸转向桥

序号 No.	零部件代号 Part No.	版本 Edition	名称 Part name		数量 Q'ty	备注 Remark	
1	ABG74-31111	02	Axle assembly	转向桥体	1		
2	ABG74-31021	01	Pin,king	右转向节	1		
3	ABG74-31041	00	Connecting rod	连杆/白锌	2		
4	ABG74-31011	01	Pin,king	左转向节	1		
5	AL734-31031	01	Swizzle	主销	2		
6	G27Z4-32011	00	Pin M12x30	紧定螺钉 M12x30	2	GB78-85	GB78-85
7	A7V94-32021	00	Link pin	连杆销	4		
8	B5050-00008	00	Washer	垫圈 8	4	GB93-87	GB93-87
9	B0530-08016	00	Bolt M8x1x16	螺栓 M8x1x16	4	GB5786-86	GB5786-86
10	Q700B06	01	Fitting	直通式滑油嘴	8	ZBT33001.1-88	ZBT33001.1-88
11	B4123-00012	00	Nut	螺母 M12	2	GB6170-86	GB6170-86
12	A7BJ4-32501	00	Bearing Z-32210	轴承 Z-32210	2		
13	AL734-31141	00	Seal-ring	密封圈	4		
14	H24C4-12003	02	Dushing	衬套	6		
15	H24C4-32061	02	Bearing	关节轴承	4		
16	AL734-30301	01	Steering cylinder	转向油缸总成	1		
17	23654-32041	02	Bolt	轮毂螺栓	16		
18	B5050-00016	00	Washer	垫圈 16	8	GB93-87	GB93-87
19	B0632-16060	00	Bolt M16x60	螺栓 M16x60	8	GB27-88	GB27-88
20	A7BJ4-32151	00	Hub,wheel	轮毂	2		
21	B3010-6P360	00	Pin 6.3x60	销 6.3x60	2	GB91-86	GB91-86
22	B5310-00030	00	Washer 30	垫圈 30	2	GB97.1-85	GB97.1-85
23	Z-30207	00	Bearing 30207	轴承 30207	2	GB/T297-94	GB/T297-94
24	AL734-31131	00	Sleeve	隔套/白锌	4		
25	Z6301-07523	00	U-ring	U形密封圈 75x100x10D	2	GB9877.1-88	GB9877.1-88
26	A21B4-32231	01	Hub cover	轮毂盖	2		
27	AL734-31071	01	Pin cover	主销盖	3		
28	A61K2-41101	02	Angle locator	转角定位器	1		
29	ABG74-31081	00	Plate	电位计定位盖	1		
30	A21B4-32311	00	Nut M30x2	螺母 M30x2	2		
31	B1210-04012	00	Screw	螺钉 M4x12	2	GB818-85	GB818-85

ABG74-30001 05 Steering axle

ABG74-30001 05 横置油缸转向桥

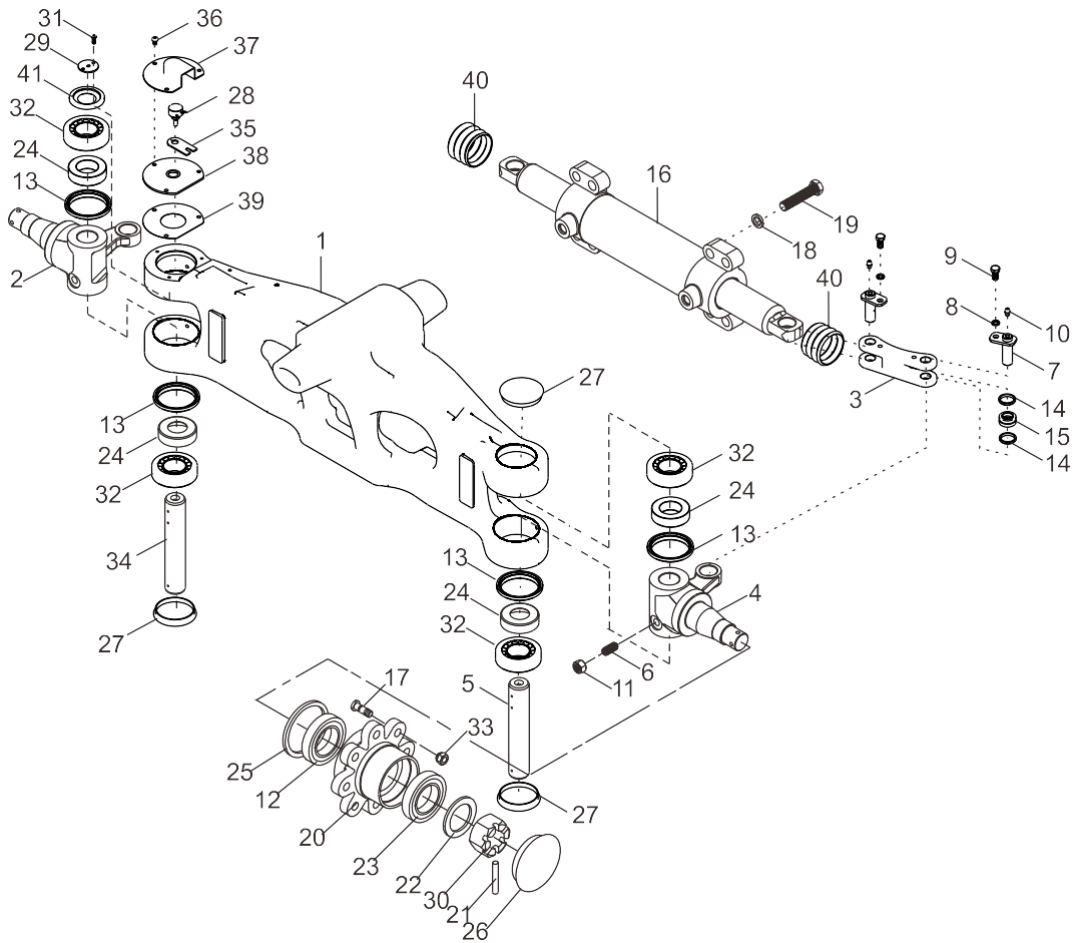

AL734-30301 01 Steering cylinder

AL734-30301 01 转向油缸总成

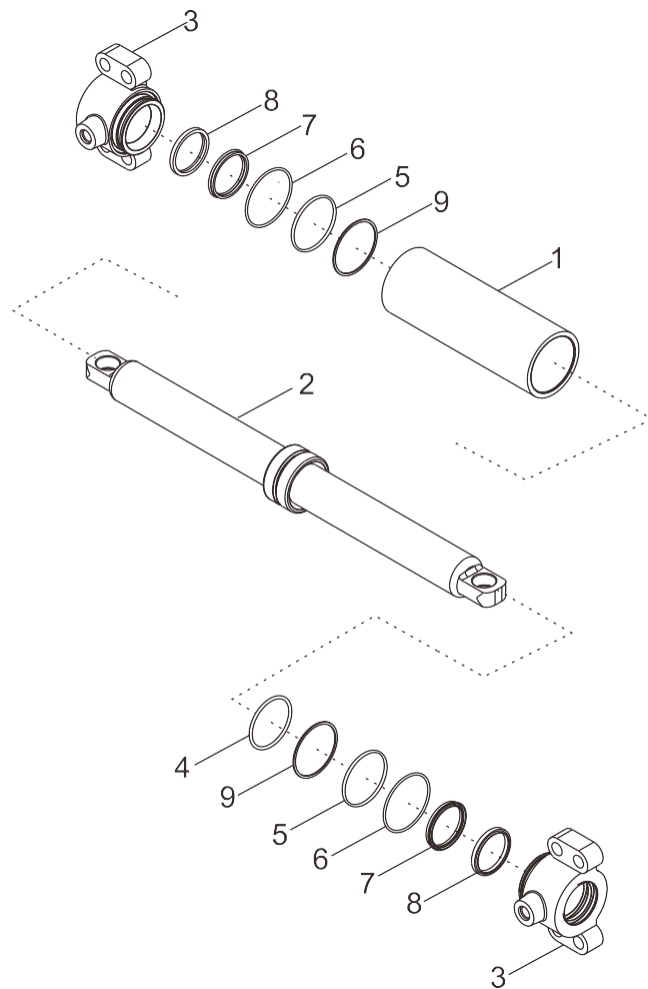

ABG74-30001N 00 Steering axle

ABG74-30001N 00 横置油缸转向桥

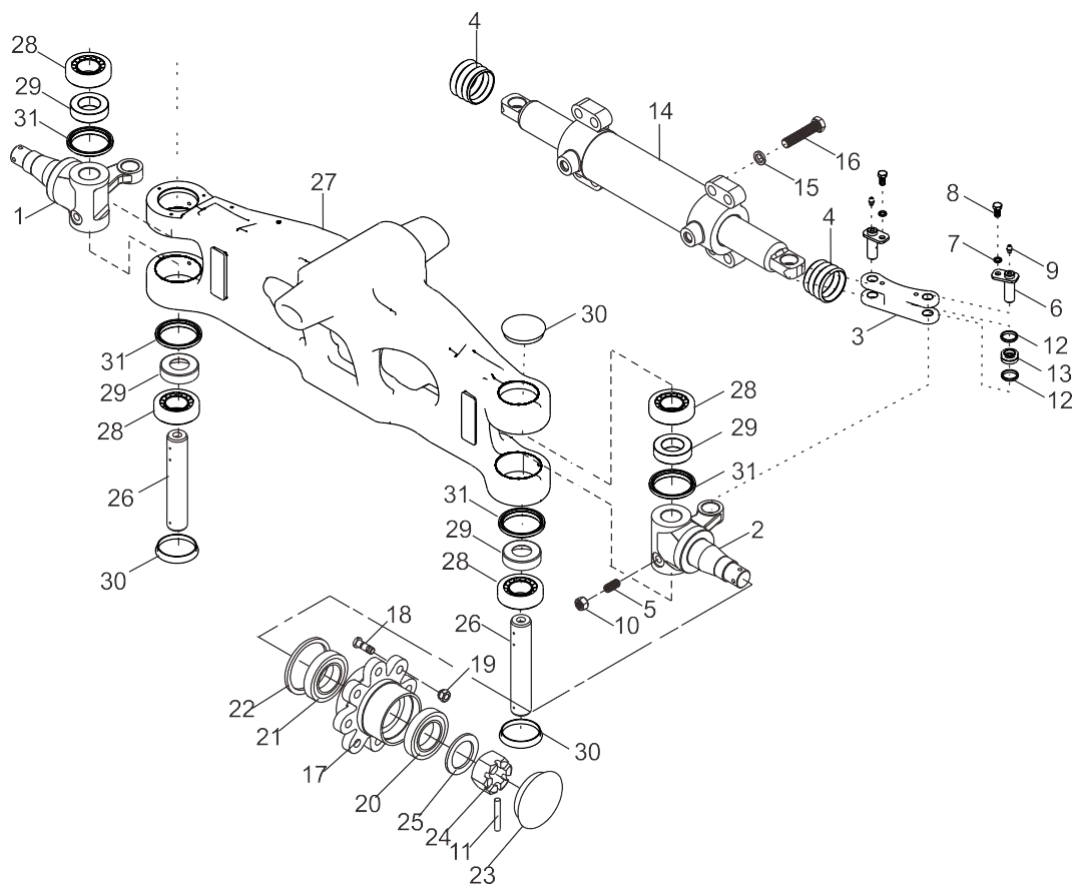

ABG74-30001N 00 Steering axle

ABG74-30001N 00 横置油缸转向桥

序号 No.	零部件代号 Part No.	版本 Edition	名称 Part name		数量 Q'ty	备注 Remark	
1	ABG74-31021	01	Pin,king	右转向节	1	HRABG741 01	HRABG741 01
2	ABG74-31011	01	Pin,king	左转向节	1	HRABG741 01	HRABG741 01
3	ABG74-31041	00	Connecting rod	连杆/白锌	2		
4	A7V94-30708CHT	00	Sleeve	中护套	2		
5	G27Z4-32011	00	Pin M12x30	紧定螺钉 M12x30	2		
6	A7V94-32021	00	Link pin	连杆销	4		
7	B5050-00008	00	Washer	垫圈 8	4	GB93-87	GB93-87
8	B0530-08016	00	Bolt M8x1x16	螺栓 M8x1x16	4	GB5786-86	GB5786-86
9	Q700B06	01	Fitting	直通式滑油嘴	8	ZBT33001.1 -88	ZBT33001.1 -88
10	B4123-00012	00	Nut	螺母 M12	2	GB6170-86	GB6170-86
11	B3010-6P360	00	Pin 6.3x60	销 6.3x60	2	GB91-86	GB91-86
12	H24C4-12003	02	Dushing	衬套	6		
13	H24C4-32061	02	Bearing	关节轴承	4		
14	AL734-30301	01	Steering cylinder	转向油缸总成	1		
15	B5050-00016	00	Washer	垫圈 16	8	GB93-87	GB93-87
16	B0632-16060	00	Bolt M16x60	螺栓 M16x60	8	GB27-88	GB27-88
17	A7BJ4-32151	00	Hub,wheel	轮毂	2		
18	23654-32041	02	Bolt	轮毂螺栓	16		
19	23654-34051	05	Nut	轮毂螺母	16		
20	Z-30207	00	Bearing 30207	轴承 30207	2	GB/T297-94	GB/T297-94
21	A7BJ4-32501	00	Bearing Z-32210	轴承 Z-32210	2		
22	Z6301-07523	00	U-ring	U形密封圈 75x100x10D	2	GB9877.1- 88	GB9877.1- 88
23	A21B4-32231	01	Hub cover	轮毂盖	2		
24	A21B4-32311	00	Nut M30x2	螺母 M30x2	2		
25	B5310-00030	00	Washer 30	垫圈 30	2	GB97.1-85	GB97.1-85
26	AL734-31031	01	Swizzle	主销	2	For potentiomet er	带电位器用
27	ABG74-32111	00	Axle assembly	转向桥体	1	For double potentiomet er	装双电位器 用
28	Z-32207	00	Bushing	轴承 32207	4	GB/T 297-94	GB/T 297-94
29	AL734-31131	00	Sleeve	隔套/白锌	4		
30	AL734-31071	01	Pin cover	主销盖	2		

ABG74-30001N 00 Steering axle

ABG74-30001N 00 横置油缸转向桥

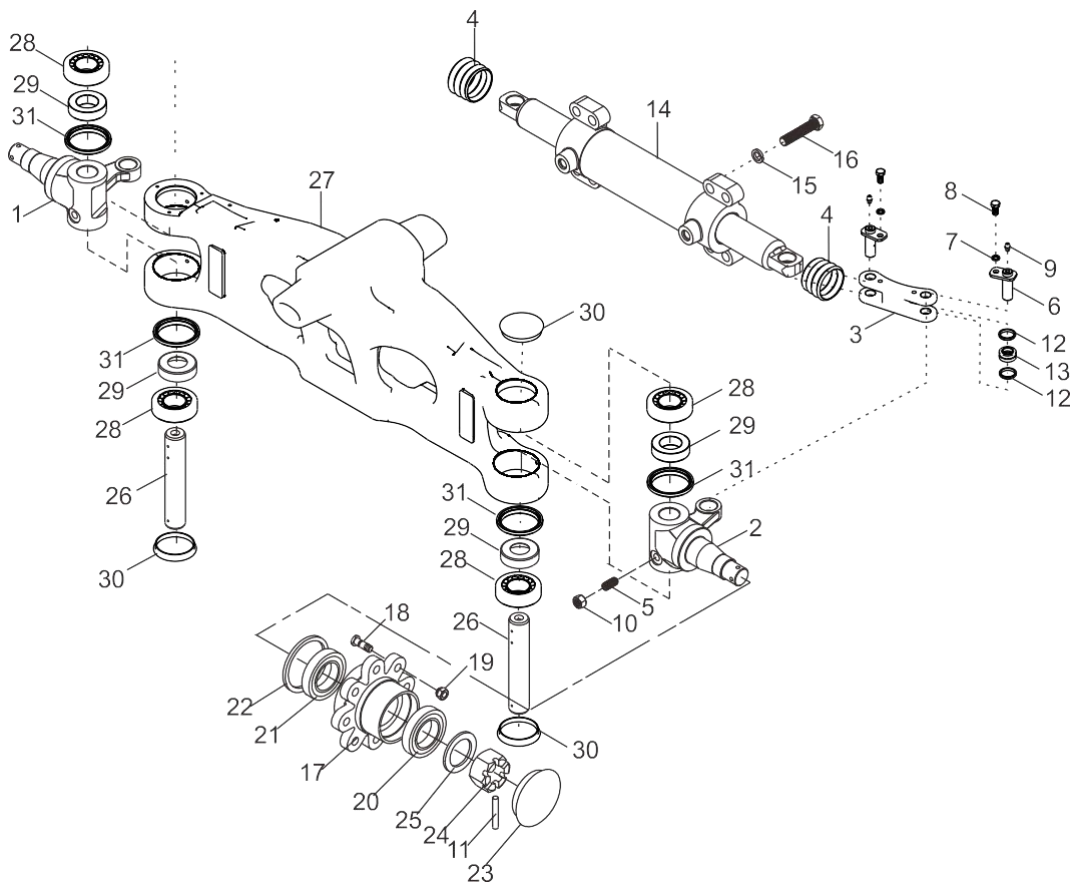

AL734-30301 01 Steering cylinder

AL734-30301 01 转向油缸总成

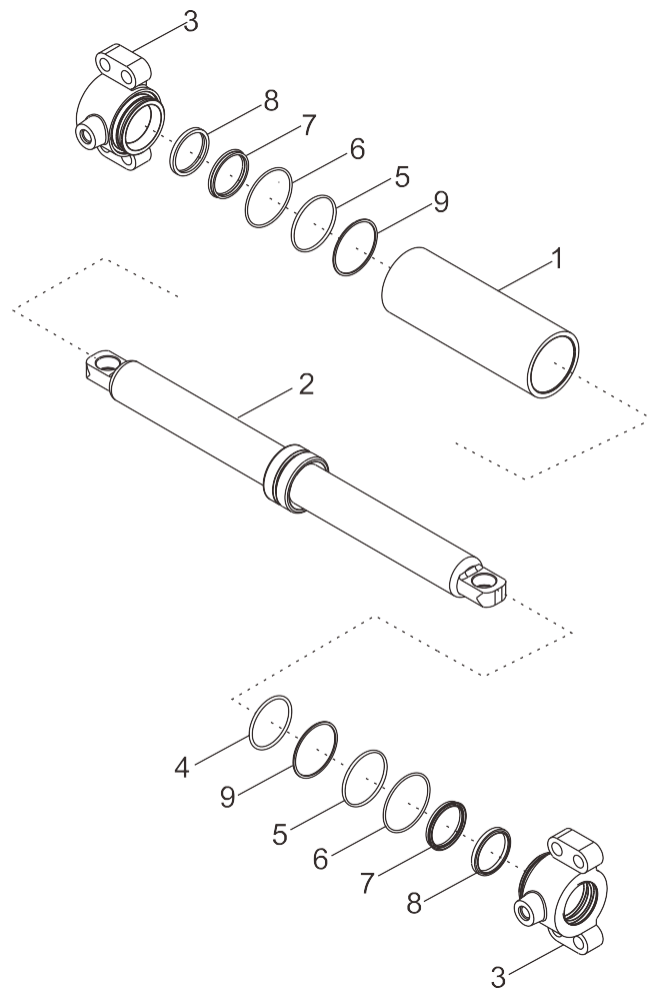

A1755-40001 02 Service brake system

A1755-40001 02 行车制动系统

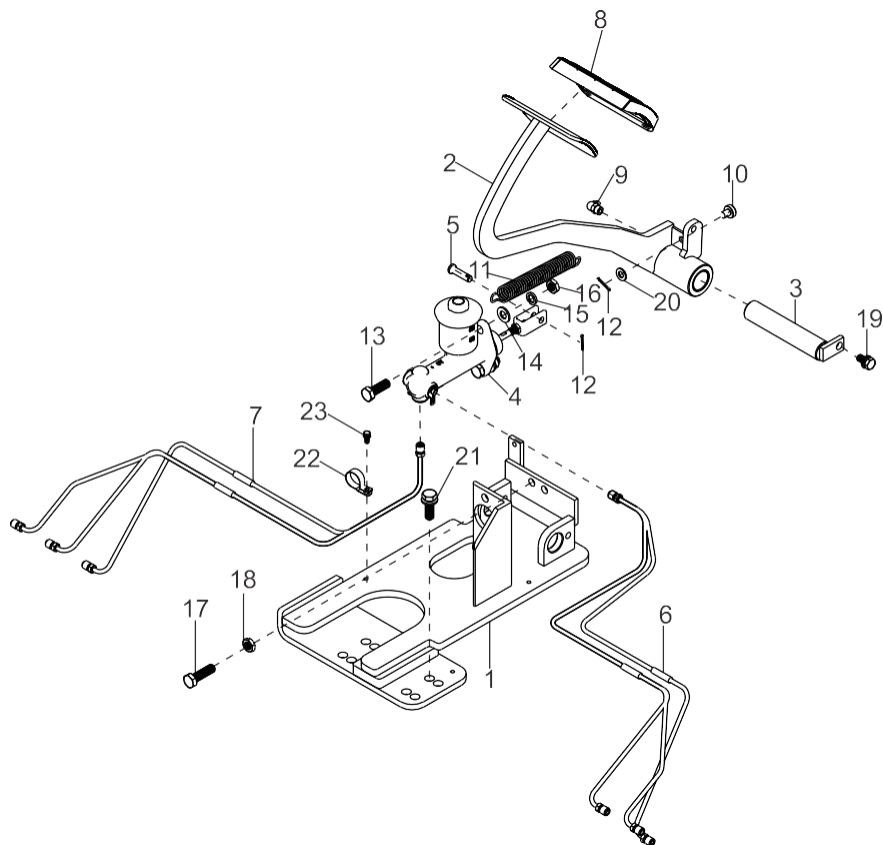

A1755-40001 02 Service brake system

A1755-40001 02 行车制动系统

序号 No.	零部件代号 Part No.	版本 Edition	名称 Part name		数量 Q'ty	备注 Remark	
1	A1755-40011	02	Bracket	制动支架	1		
2	A1755-40201	00	Pedal,brake	制动踏板	1		
3	15D20-20	00	Shaft,oil	油轴	1		
4	A7T75-40401	02	Brake pump	制动总泵	1		
5	B3220-08030	00	Pin B8x30	销 B8x30	1	GB882-86	GB882-86
6	A1675-40301	00	Steel tube L.H.	制动钢管总成左	1	1.5- For small 2t	1.5-小 2 吨用
6	A1755-40301	00	Steel tube L.H.	制动钢管总成左	1	2-2.5t	2-2.5 吨用
6	A1815-40301	00	Steel tube L.H.	制动钢管总成左	1	3-3.5t	3-3.5 吨用
7	A1675-40401	00	Brake tube assembly right	制动钢管总成右	1	1.5- For small 2t	1.5-小 2 吨用
7	A1755-40401	00	Brake tube assembly right	制动钢管总成右	1	2-2.5t	2-2.5 吨用
7	A1815-40401	00	Brake tube assembly right	制动钢管总成右	1	3-3.5t	3-3.5 吨用
8	A7S35-42111	01	Cover,pedal head	踏板垫	1		
9	Z2513-01010	00	Cup	油杯 90° M10X1	1	JB/T 7940.2-1995	JB/T 7940.2-1995
10	H25S5-43211	00	Nylon jacking	尼龙顶轴	1		
11	15D20-00-01	00	Spring	拉簧	1		
12	B3010-02016	00	Pin 2 x16	销 2x16	2	GB91-86	GB91-86
13	B0330-10030	00	Bolt	螺栓 M10x30	2	GB5783-86	GB5783-86
14	B5310-00010	00	Washer	垫圈 10	2	GB97.1-85	GB97.1-85
15	B5050-00010	00	Washer	垫圈 10	2	GB93-87	GB93-87
16	B4313-00010	00	Nut	螺母 M10	2	GB6172-86	GB6172-86
17	B0530-10035	00	Bolt	螺栓 M10x1.25x35	1	GB5786-86	GB5786-86
18	B4413-00010	00	Nut	螺母 M10x1.25	1	GB6173-86	GB6173-86
19	B0330-08016-X	00	Combined bolt	组合螺栓 M8x16	1	GB/T 9074.17-88	GB/T 9074.17-88
20	B5310-00008	00	Washer	垫圈 8	1	GB97.1-85	GB97.1-85
21	B0330-10030-X	00	Combined bolt	组合螺栓 M10x30	4	GB/T 9074.17-88	GB/T 9074.17-88
22	D1252-1116	00	Clip	线卡	1		
23	B0330-06016-X	00	Combined bolt	组合螺栓 M6×16	1	GB5783,GB 93,GB97.1	GB5783,GB 93,GB97.1

ABG73-60001 02 Hand brake assembly

ABG73-60001 02 手制动装置总成

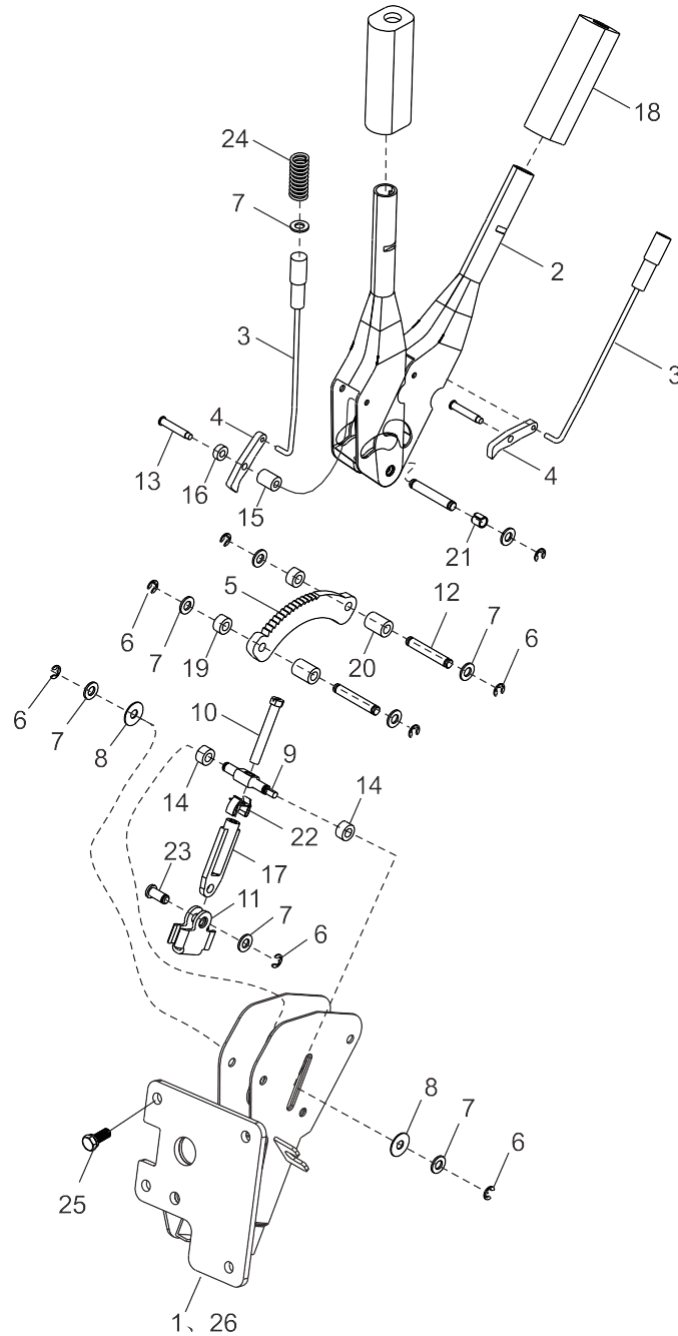

ABG73-60001 02 Hand brake assembly

ABG73-60001 02 手制动装置总成

序号 No.	零部件代号 Part No.	版本 Edition	名称 Part name		数量 Q'ty	备注 Remark	
1	ABG73-60501	00	Hand brake bracket assembly	手制动支架总成	1		
2	H9MF5-50301	00	Lever	手柄总成	1		
3	G2TA5-50401	01	Push rod	推杆总成	1		
4	G2TA5-52101	02	Pawl	棘爪	1		
5	G2TA5-52111	03	Ratch	棘齿	1		
6	B6250-00006	00	Snap ring	挡圈 6	9	GB896-86	GB896-86
7	B5310-00008	00	Washer	垫圈 8	10	GB97.1-85	GB97.1-85
8	239A5-58101	00	Washer	垫圈	2		
9	G2TA5-52131	02	Pin	连接销	1		
10	G2TA5-52201	01	Bolt	螺栓 M8×55	1	GB29.1-88	GB29.1-88
11	21235-52171G	01	Bracket	挂线架	1		
12	G2TA5-52121	02	Pin	固定销	3		
13	G2TA5-52141	02	pin	销轴	1		
14	239A5-54101	00	Sleeve	套	2		
15	G2TA5-52151	03	Sleeve	套筒 1	1		
16	G2TA5-52161	03	Sleeve	套筒 2	1		
17	239A5-50140	00	Rod	拉杆	1		
18	Q64H5-52001	02	Sheath	手柄套	1		
19	G2TA5-52181	03	Sleeve	套筒 4	2		
20	G2TA5-52171	03	Sleeve	套筒 3	2		
21	Z2111-00810	00	Bushing	钢背轴承 0810	2	Q/AC40001- 2002	Q/AC40001- 2002
22	G2TA5-52191	01	Catch	弹簧卡	1		
23	239A5-53101	00	Shaft	轴	1		
24	239A5-52101	00	Spring	弹簧	1		
25	B0330-08020-X	00	Combined bolt	组合螺栓 M8x20	3	GB/T9074.1 7-88	GB/T9074.1 7-88
26	ABG73-60401	01	Hand brake	手制动总成	1	Include 1-24	包含 1-24

HRA1TV6101 00 Frame assembly

HRA1TV6101 00 车架总成

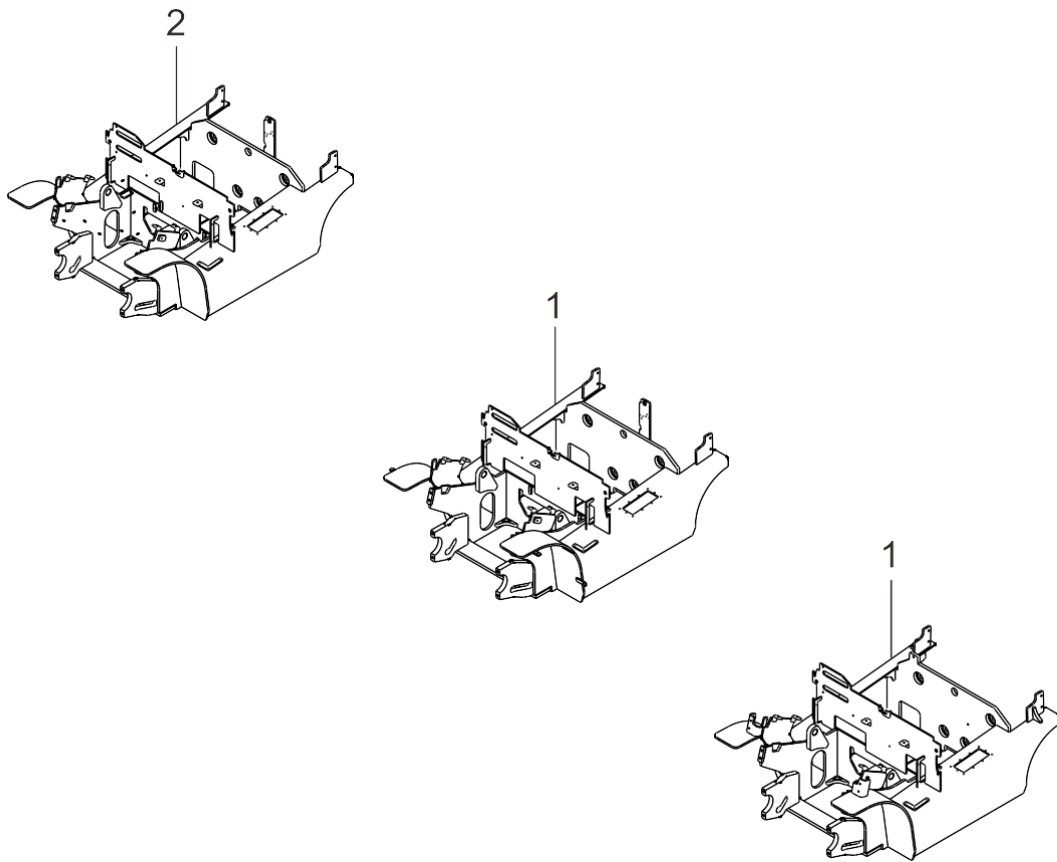

HRA1TV6301 00 Counterweight system

HRA1TV6301 00 平衡重系统

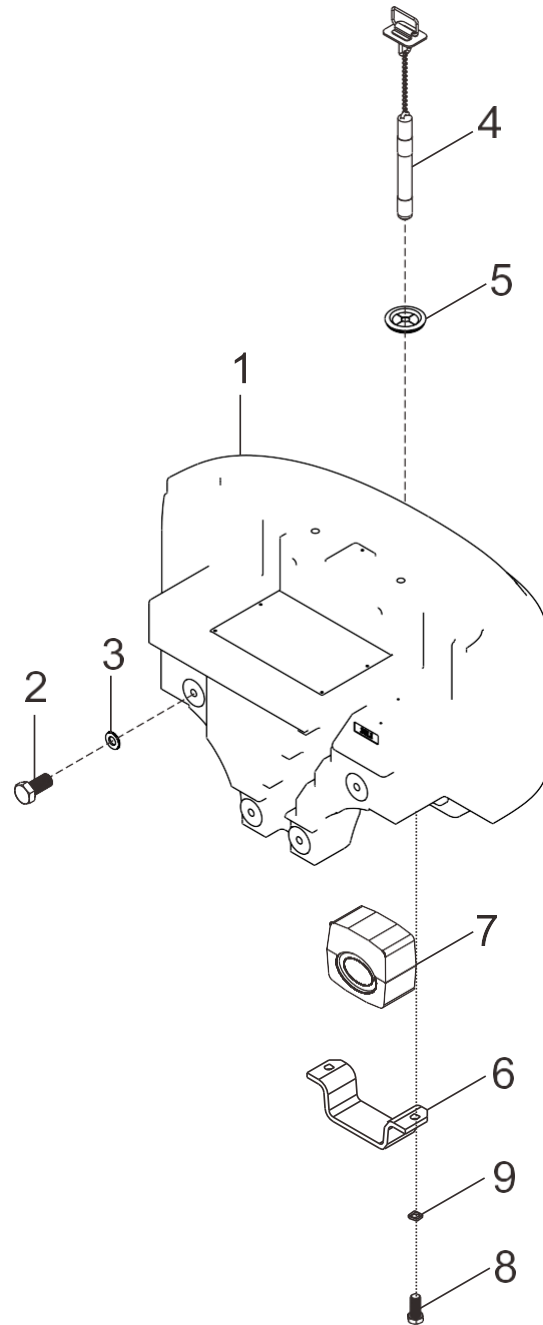

HRA1TP6401 00 Hood

HRA1TP6401 00 机罩类

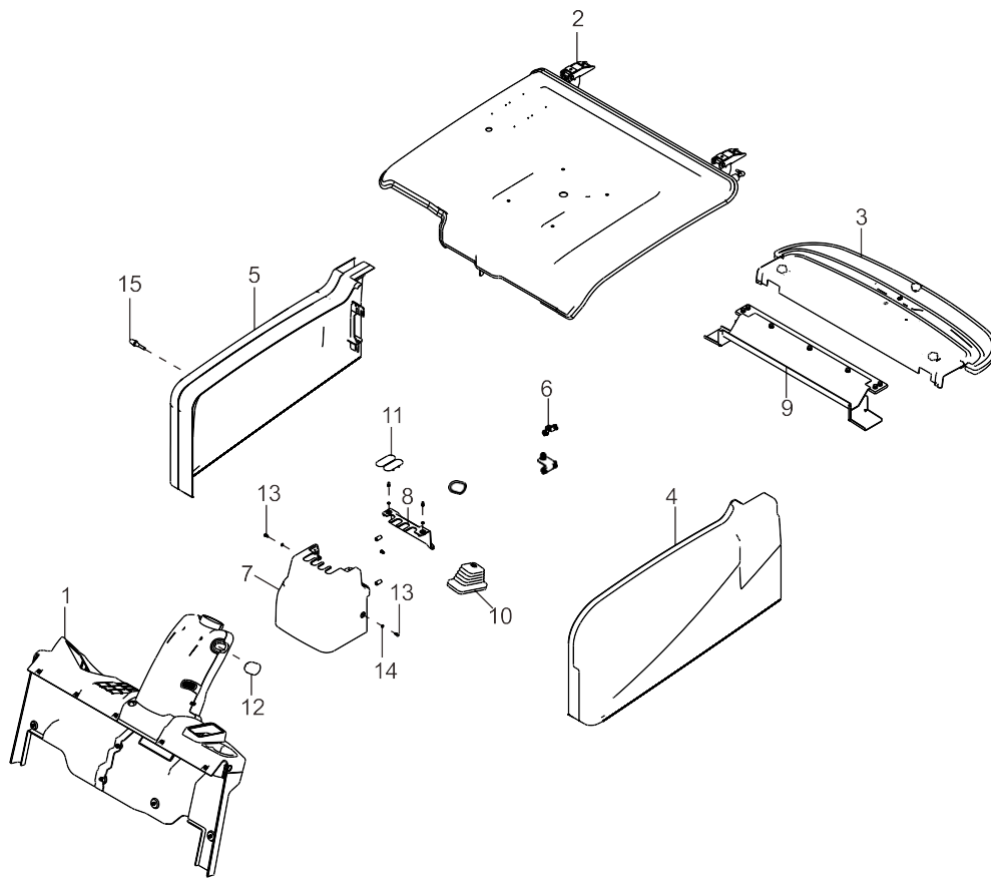

A1756-40101 01 Instrument desk mouting

A1756-40101 01 仪表台安装

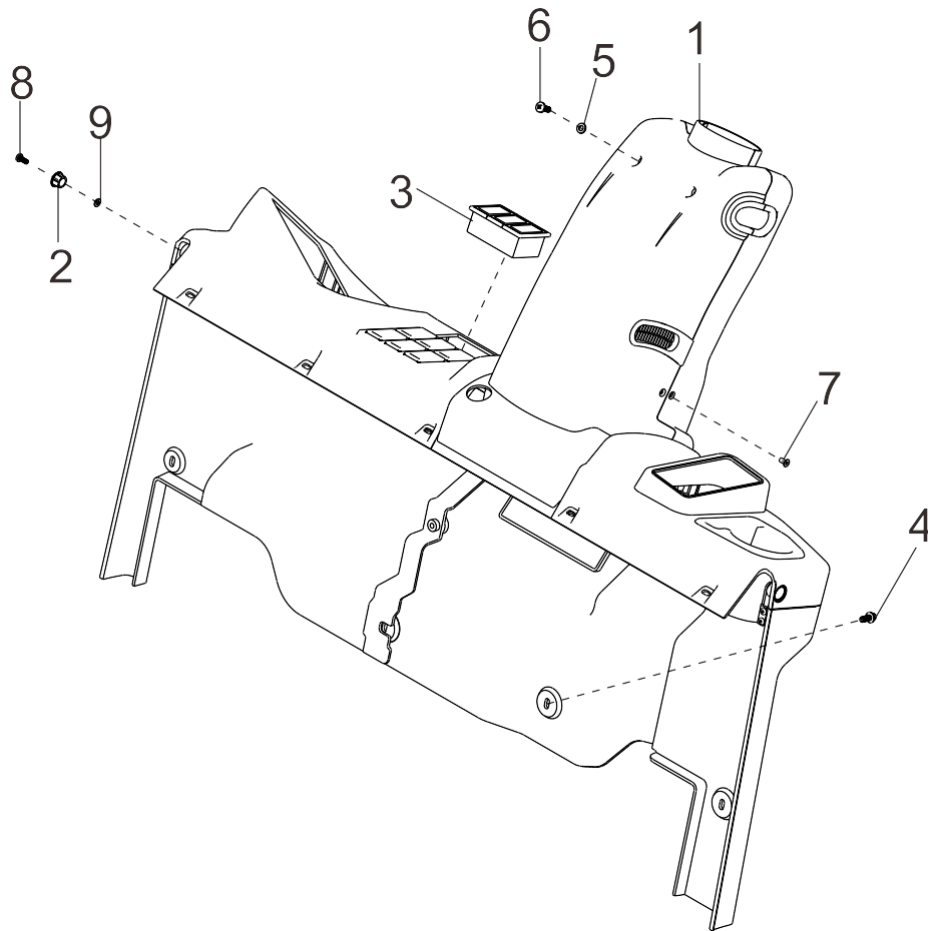

A1756-40201 01 Battery cover plate assembly ?

A1756-40201 01 蓄电池盖板总成

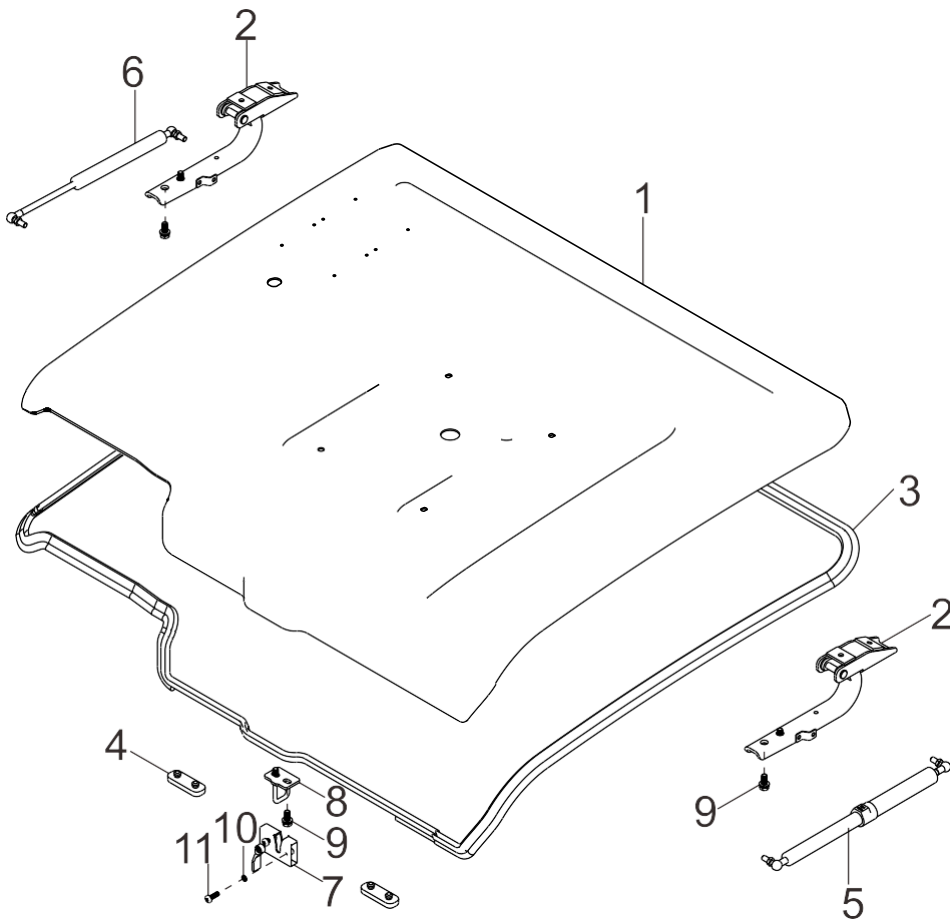

HRA1TP6411 00 Counterweight cover board assembly ?

HRA1TP6411 00 配重盖板总成

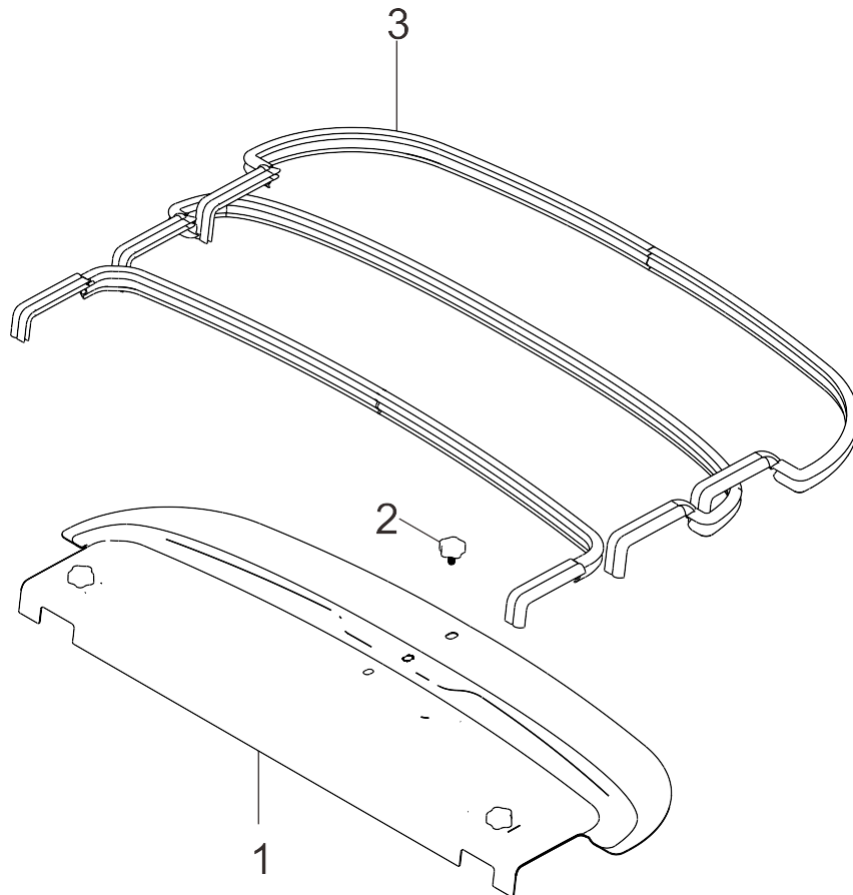

HRA1756431 00 Side cover mounting accessories ?

HRA1756431 00 侧罩安装附件

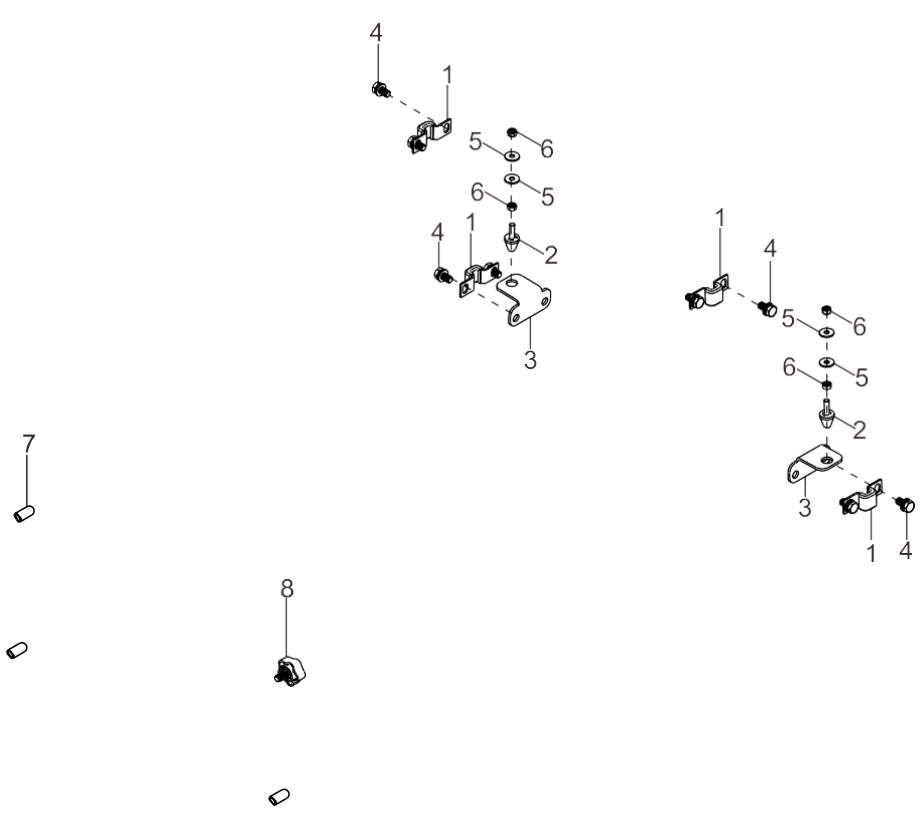

A1676-40611 00 Installation of water guide plate ?

A1676-40611 00 导水板安装

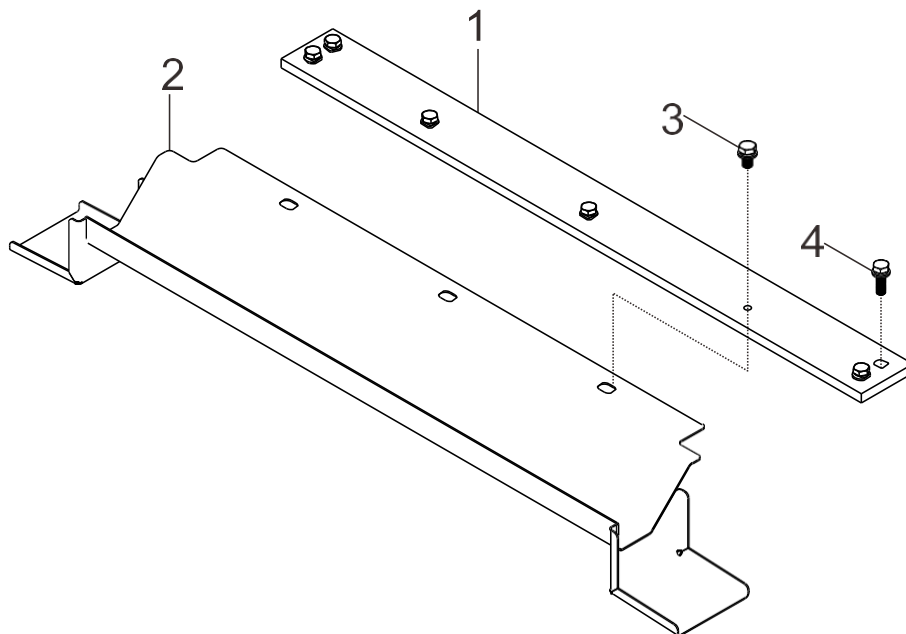

HRA1TP6501 01 Floor class

HRA1TP6501 01 地板类

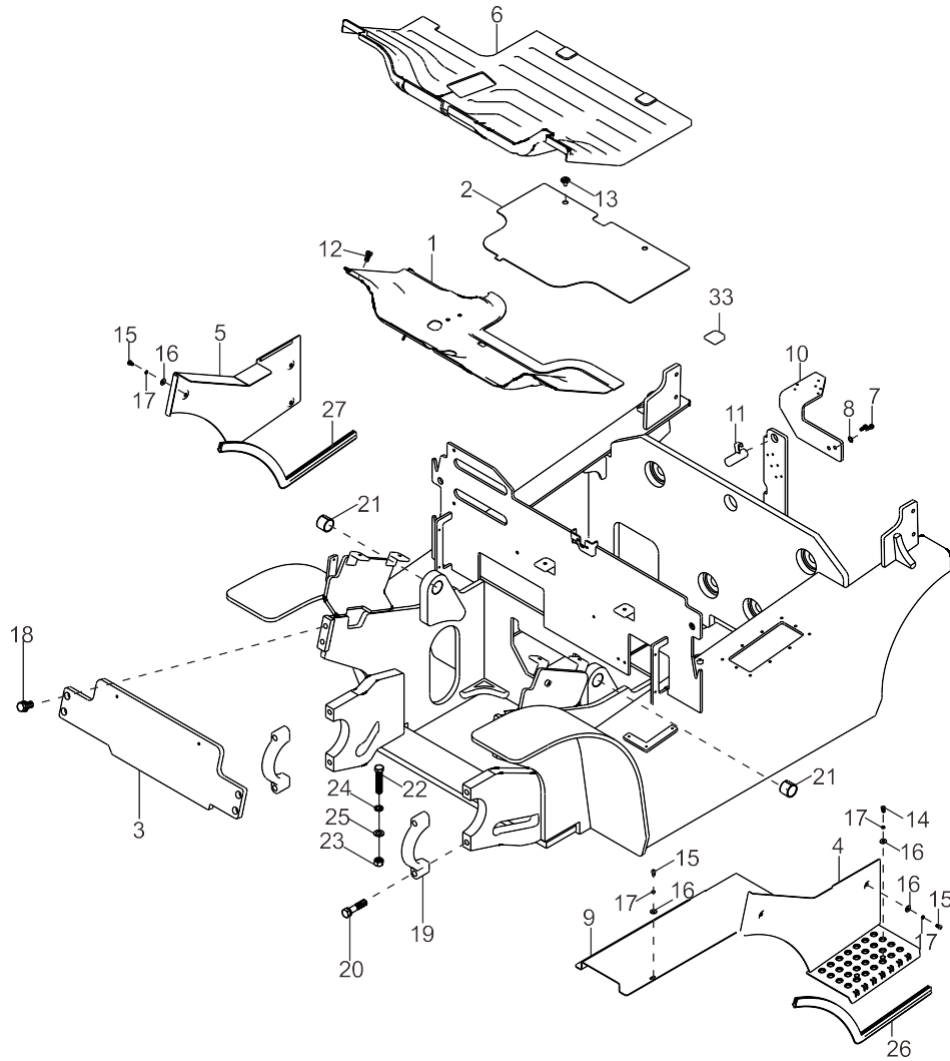

HRA1TP6501 01 Floor class							
HRA1TP6501 01 底板类							
序号 No.	零部件代号 Part No.	版本 Edition	名称 Part name		数量 Q'ty	备注 Remark	
1	A1756-50011	02	Floor board,front	前底板总成	1		
2	A1756-50021	01	Floor board,rear	后底板总成	1		
3	A1756-50031	02	Front sash assembly	前横板总成	1	2-3.8t	2-3.8t
3	A1676-50031	02	Front sash assembly	前横板总成	1	1.5-small2t	1.5-小 2t
4	A1816-50041	01	Left guard assembly	左护罩总成	1	3-3.8t	3-3.8t
4	A1756-50041	02	Left guard assembly	左护罩总成	1	2-2.5t	2-2.5t
4	A1676-50041	02	Left guard assembly	左护罩总成	1	1.5-small2t	1.5-小 2t
5	A1756-50051	01	Right guard assembly	右护罩总成	1		
6	A1756-52061	01	Cushion	底板垫	1		
7	A1TP6-50011	00	Electrical mounting plate assembly	电气安装板总成	1		
8	A1TP6-52011	00	Support plate	支撑板	1		
9	A7T76-50801	00	Cover assembly	盖板总成	1		
9	A1756-50061	00	Cover assembly	盖板总成	1	2-2.5t	2-2.5t
9	A1676-50061	00	Cover assembly	盖板总成	1	1.5-small2t	1.5-小 2t
10	A1TP6-52021	01	Motor mounting plate	电机安装板	1	3-3.8t	3-3.8t
10	A1TV6-50021	00	Motor mounting plate assembly	电机安装板总成	1	2-2.5t	2-2.5t
11	A7S36-50041	02	Pin	箱体固定销	1		
12	B0530-10020-X1	00	Combined bolt M10x1.25x20	组合螺栓 M10x1.25x20	2	GB5786,GB93	GB5786,GB93
13	22496-51001G	01	Screw	螺钉	2		
14	B0330-06012	00	Bolt	螺栓 M6x12	2	GB5783-86	GB5783-86
15	B1210-06012	00	Screw	螺钉 M6x12	10	GB818-85	GB818-85
16	B5210-00006	00	Washer,lock	垫圈 6	12	GB96-85	GB96-85
17	B5050-00006	00	Washer,lock	垫圈 6	12	GB93-87	GB93-87
18	B0530-16035-X	00	Combined bolt M16x1.5x35	组合螺栓 M16x1.5x35	4	GB5786,GB93,GB97.1	GB5786,GB93,GB97.1
19	22018-30064	02	Mast support cover	门架支座盖	2		
19	24236-12632	01	Cap	支座盖	2		
20	B0430-16070-X1	00	Combined bolt M16x1.5x70	组合螺栓 M16x1.5x70	4	GB5785,GB93	GB5785,GB93
20	B0430-14070-X1	00	Combined bolt M14x1.5x70	组合螺栓 M14x1.5x70	4	GB5785,GB93	GB5785,GB93
21	Z2133-03530	00	Bushing 3530	钢背轴承 3530	2	Q/AC40001-2002	Q/AC40001-2002
22	B0330-20100	00	Bolt M20x100	螺栓 M20x100	1	GB5783-86	GB5783-86
23	B4130-00020	00	Nut M20	螺母 M20	1	GB6170-86	GB6170-86

HRA1TP6501 01 Floor class

HRA1TP6501 01 地板类

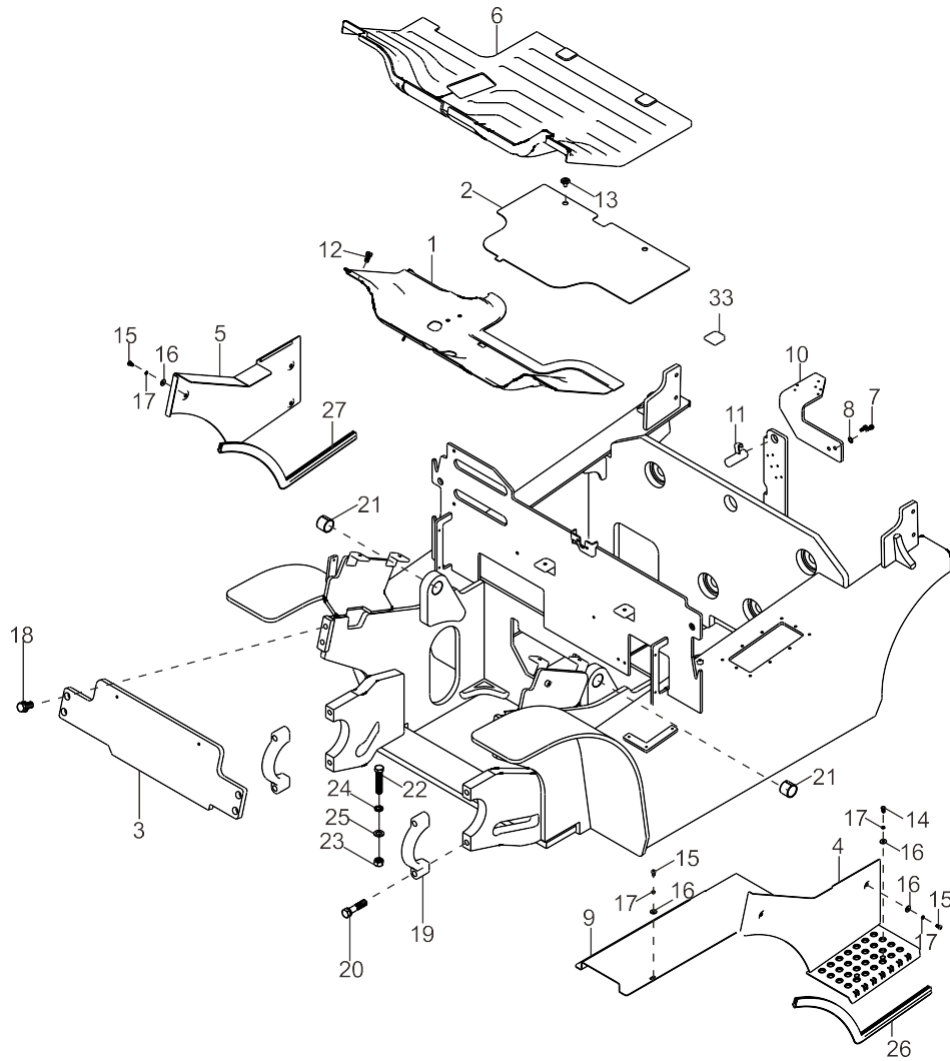

HRA6S58001 08 Seats

HRA6S58001 08 座椅总图

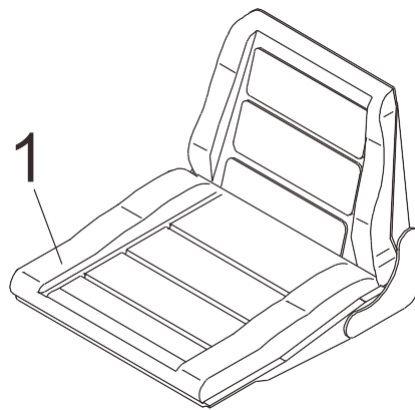

HRA6S58001 08 Seats

HRA6S58001 08 座椅总图

序号 No.	零部件代号 Part No.	版本 Edition	名称 Part name		数量 Q'ty	备注 Remark	
1	A61Q6-80002	04	Tiancheng half suspension seat	天成半悬浮座椅（带安全开关，扶手，安全带）	1		
1	A61Q6-80032	06	Tiancheng half suspension seat	天成半悬浮座椅	1		
1	H24C6-80162	00	Tiancheng whole suspension seat	天成全悬浮座椅	1		
1	H24C6-80162WZ	00	Tiancheng whole suspension seat	天成全悬浮座椅	1		
1	A61Q6-81032	00	Gramm half suspension seat	格拉姆半悬浮座椅	1		
1	A61Q6-81042	00	Gramm half suspension seat	格拉姆半悬浮座椅	1		
1	A7V96-80002	00	Hean half surround seat	和安半包围普通座椅	1	Normal	标配
1	A7V96-80012	00	Hean half surround seat	和安半包围普通座椅	1		
1	H2KE6-80112	00	Hean half surround,whole suspension seat	和安半包围全悬浮座椅	1		
1	H2KE6-80132	00	Hean half surround,whole suspension seat	和安半包围全悬浮座椅	1		
1	H2KE6-80032	00	Hean seat with handrail	和安带扶手普通座椅	1		
1	H2KE6-80052	00	Hean seat with handrail	和安带扶手普通座椅	1		
1	H2KE6-80072	00	Hean with handrail, whole suspension seat	和安带扶手全悬浮座椅	1		
1	H2KE6-80092	00	Hean with handrail, whole suspension seat	和安带扶手全悬浮座椅	1		
1	A7BJ6-80011	00	Gramm whole suspension ordinary seat	格拉默全悬浮普通座椅	1		
1	H2KE6-80112FSBM	01	Hean half surround,whole suspension seat	和安半包围全悬浮座椅	1		
1	H24C6-80202WZ	00	Hean semi suspension seat	和安半悬浮座椅	1		
1	A67Z6-80011	01	Grammer full hover seat	格拉默全悬浮座椅	1		
1	H2KE6-80072G	00	Hean whole suspension seat	和安全悬浮座椅	1		
1	H24C6-81001TD	00	Grammer multipurpose armrest seat	格拉默多功能扶手座椅	1		
1	A7V96-80002G-50	00	And mounting semi - enclosed booster seat	和安半包围加高座椅	1		
1	H2KE6-80112FSBMTD	01	Hean whole suspension seat	和安全悬浮座椅	1		
1	H2KE6-80072A	00	Hean with handrail, whole suspension seat	和安带扶手全悬浮座椅	1		

A7V96-80012 00 Hean half surround seat

A7V96-80012 00 和安半包围普通座椅



H2KE6-80112FSBMTD 00 Hean whole suspen- sion seat

H2KE6-80112FSBMTD 00 和安全悬浮座椅

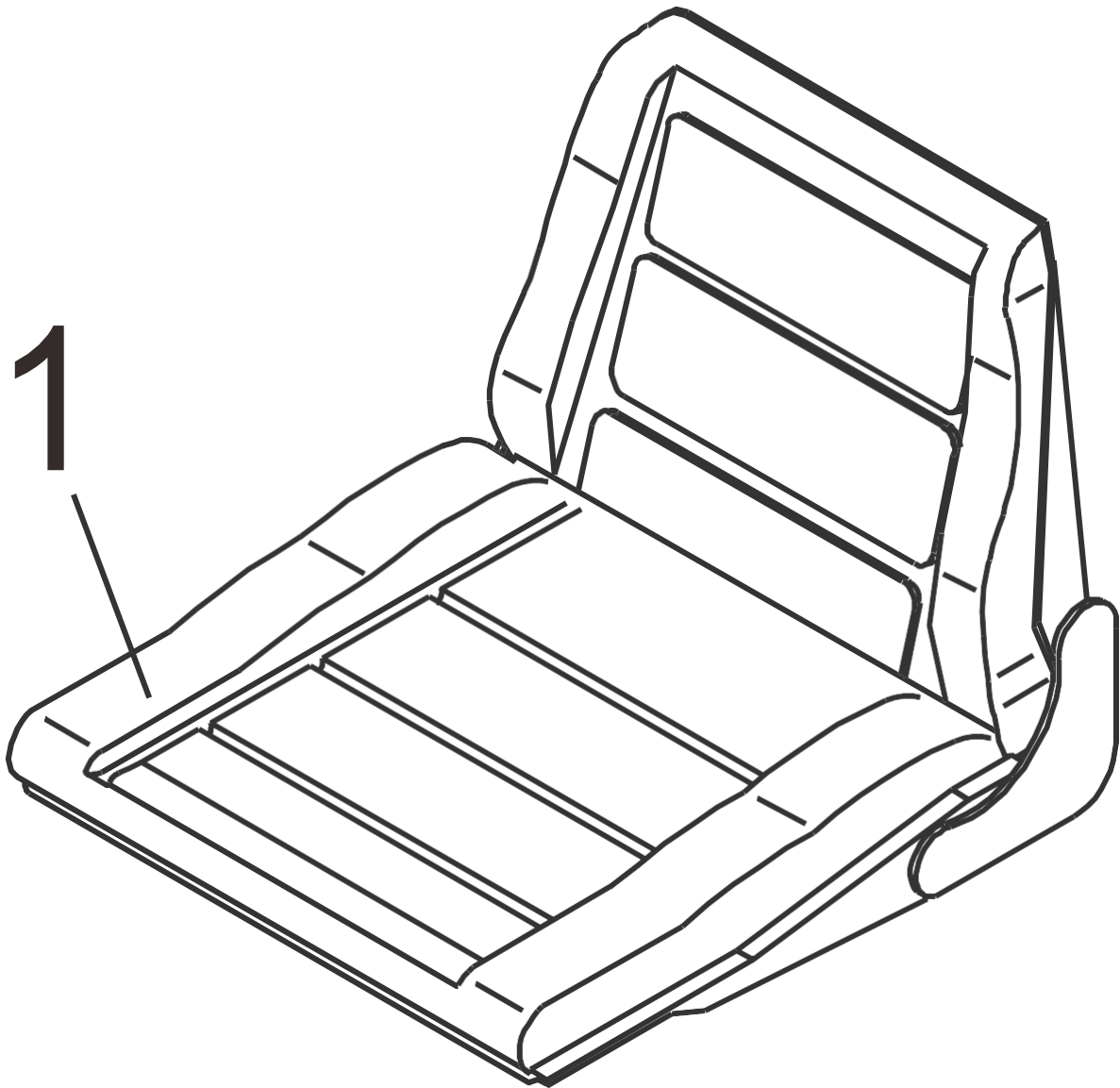

A1755-70001 01 Cab

A1755-70001 01 驾驶室

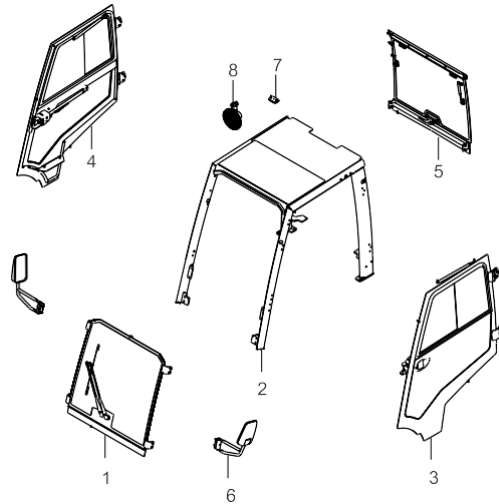

A1755-70021 00 Front window ass'y

A1755-70021 00 前窗总成

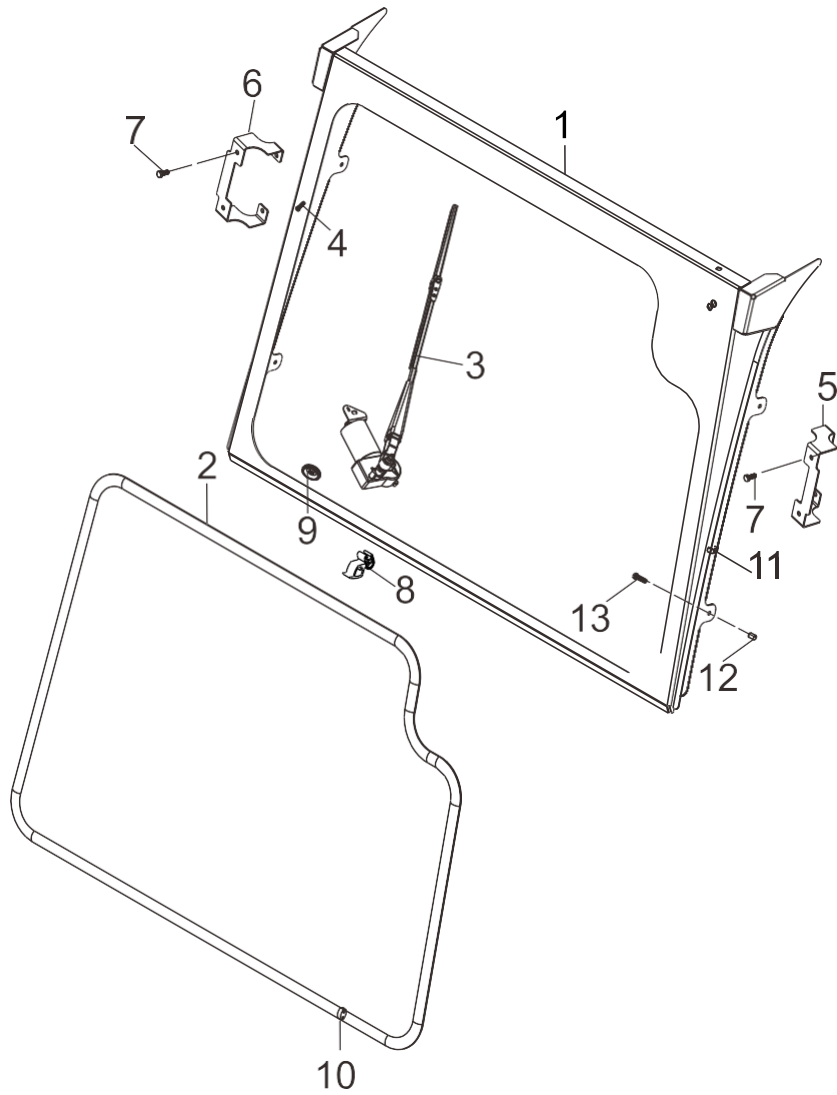

A1755-70031 00 Copping assembly

A1755-70031 00 顶部总成

序号 No.	零部件代号 Part No.	版本 Edition	名称 Part name		数量 Q'ty	备注 Remark	
1	A1755-70301	00	Lifting cover plate assembly	吊装盖板总成	1		
2	JH2000-0700P	01	Glass	顶窗玻璃	1		
3	A1755-73021	00	Gasket plate	密封垫板	1		
4	A7V95-72361	00	Plate	垫板	1		
5	B0330-08055-X	00	Combined outer hexagon bolt	组合外六角螺栓 M8x55	2	GB5783-86	GB5783-86
6	A7V95-72171	00	Septum board	勾板	2		
7	A7V95-72181	00	Handle	五星把手 M8x45	2		
8	G0U25-76051	00	Seal	密封条(侧气囊)	1		

A1755-70041L 00 Side door ass'y

A1755-70041L 00 侧门总成(左)

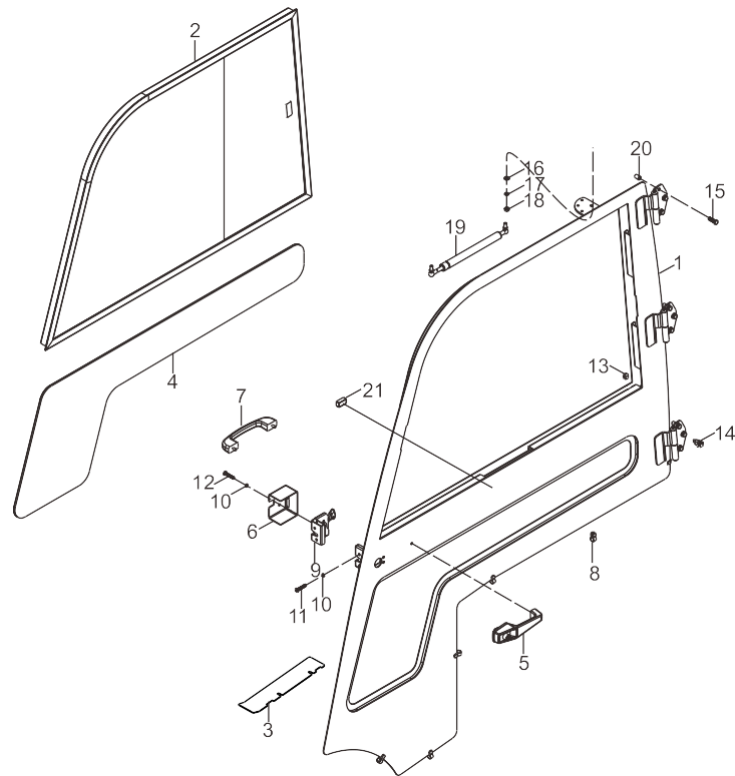

A1755-70041L 00 Side door ass'y

A1755-70041L 00 侧门总成(左)

序号 No.	零部件代号 Part No.	版本 Edition	名称 Part name		数量 Q'ty	备注 Remark	
1	A1755-70401L	00	Side door welded frame	侧门焊接框架	1		
2	A1755-70411L	00	Push-pull window	推拉窗	1		
3	A1755-74071L	00	Plate	下封板(左)	1		
4	G0U25-74651L	00	Glass L.H.	左侧门玻璃	1		
5	DS502L	01	Side door lock assembly, L.H.	侧门锁总成(左)	1		
6	P62A5-72571L	03	Box L.H.	锁盒(左)	1		
7	Ja0308-0000B	02	Handle	小拉手	1		
8	JZX-70007	03	Sealing strip	玻璃密封条	1		
9	G0U25-70471NL	01	Pole,lock L.H.	锁柱总成(左)	1		
10	B5050-00006	00	Washer,lock	垫圈 6	2	GB93-87	GB93-87
11	B1210-06035	00	Screw	螺钉 M6x35	2	GB818-85	GB818-85
12	B1210-06020	00	Screw	螺钉 M6x20	5	GB818-85	GB818-85
13	G0U25-76051	00	Seal	密封条(侧气囊)	1		
14	P32F5-73411	01	Sealing vertical bar	密封竖条(直气囊)	2		
15	B0330-08020-X	00	Combined bolt	组合螺栓 M8x20	8	GB/T 9074.17-88	GB/T 9074.17-88
16	B5310-00008	00	Washer	垫圈 8	3	GB97.1-85	GB97.1-85
17	B5050-00008	00	Washer	垫圈 8	3	GB93-87	GB93-87
18	B4123-00008	00	Nut	螺母 M8	3	GB6170-86	GB6170-86
19	A7BZ5-74351	01	Gas spring	气弹簧	1		
20	H24C5-12612	03	Nut	柳螺母M8	6		
21	6TY40-33-09	00	Plate	侧门二级开启提示标贴	1		

A1755-70041R 00 Side door ass'y

A1755-70041R 00 侧门总成(右)

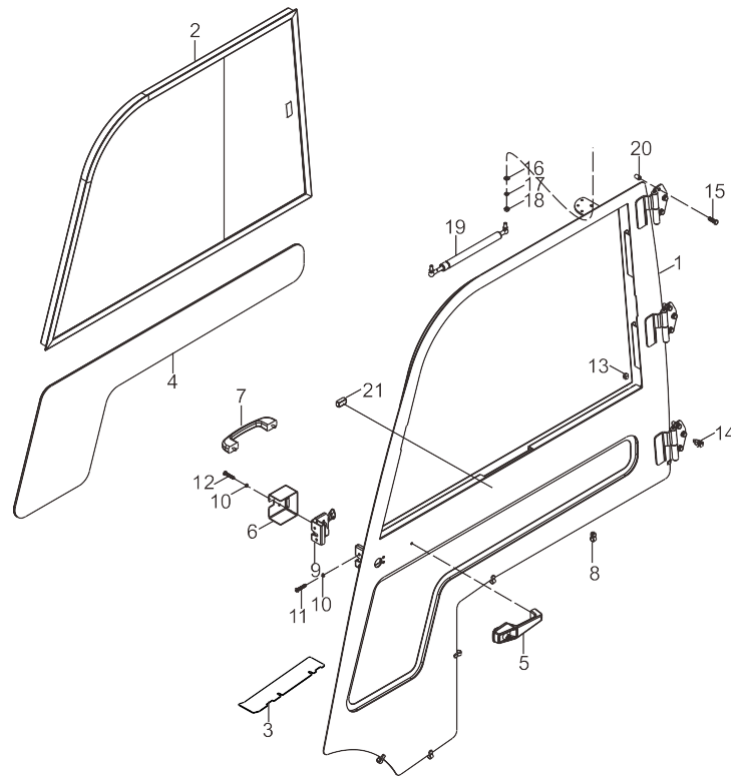

A1755-70041R 00 Side door ass'y

A1755-70041R 00 侧门总成(右)

序号 No.	零部件代号 Part No.	版本 Edition	名称 Part name		数量 Q'ty	备注 Remark	
1	A1755-70401R	00	Side door welding frame (right)	侧门焊接框架 (右)	1		
2	A1755-74071R	00	Plate	下封板 (右)	1		
3	A1755-70411R	00	Push-pull window	推拉窗 (右)	1		
4	JZX-70007	03	Sealing strip	玻璃密封条	1		
5	G0U25-74651R	00	Glass R.H.	右门下玻璃	1		
6	Ja0308-0000B	02	Handle	小拉手	1		
7	DS502R	01	Door lock assembly right	门锁总成 (右)	1		
8	B1210-06020	00	Screw	螺钉 M6x20	5	GB818-85	GB818-85
9	P62A5-72571R	02	Box R.H.	右锁盒	1		
10	B5050-00006	00	Washer,lock	垫圈 6	2	GB93-87	GB93-87
11	B1210-06035	00	Screw	螺钉 M6x35	2	GB818-85	GB818-85
12	6TY40-33-09	00	Plate	侧门二级开启提示标贴	1		
13	A7BZ5-74351	01	Gas spring	气弹簧	1		
14	H24C5-12612	03	Nut	铆螺母M8	6		
15	B0330-08025-X	00	Combined bolt	组合螺栓 M8x25	6	GB/T 9074.17-88	GB/T 9074.17-88
16	B5310-00008	00	Washer	垫圈 8	3	GB97.1-85	GB97.1-85
17	B5050-00008	00	Washer	垫圈 8	3	GB93-87	GB93-87
18	B4123-00008	00	Nut	螺母 M8	3	GB6170-86	GB6170-86
19	G0U25-76051	00	Seal	密封条(侧气囊)	1		
20	B0330-08020-X	00	Combined bolt	组合螺栓 M8x20	2		
21	G0U25-70471NR	01	Pole,lock R.H.	锁柱总成 (右)	1		
22	P32F5-73411	01	Sealing vertical bar	密封竖条(直气囊)	1		

A1755-70051 00 Rear window ass'y

A1755-70051 00 后窗总成

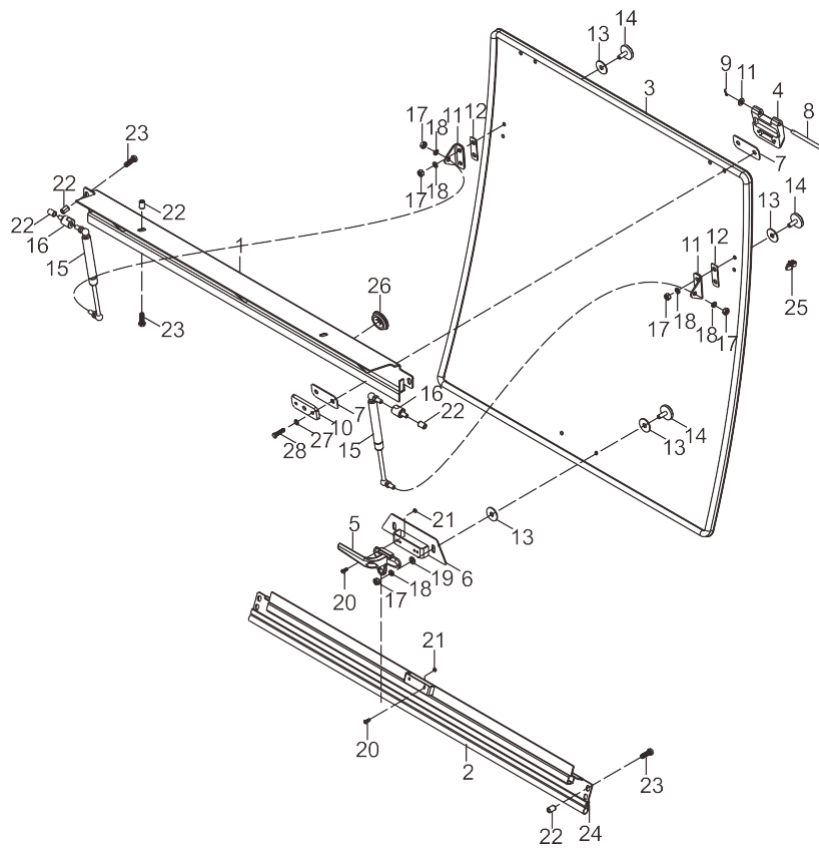

A1755- 00 1 00 Rear window ass'y

A1755-70051 00 后窗总成

序号 No.	零部件代号 Part No.	版本 Edition	名称 Part name		数量 Q'ty	备注 Remark	
1	A1755-70501	00	Crossbeam	后窗上横梁总成	1		
2	A1755-70511	00	Crossbeam	后窗下横梁总成	1		
3	A6V75-72341	00	Rear window	后窗玻璃	1		
4	G0U25-75001	00	Hinge joint	后窗铰链	2		
5	KM915-70101U	00	Handle	转动把手	1		
6	A7G55-70531	00	Jointing	玻璃衬板焊接	1		
7	G0U25-75281	00	Rubber I	橡胶垫I	4		
8	G0U25-75271	01	Shaft	轴	2		
9	B3010-02014	00	Pin 2x14	销 2x14	2	GB91-86	GB91-86
10	G0U25-75261	00	Plate	塑料垫板	2		
11	G0U25-75041	00	Bracket	气弹簧支座	2		
12	G0U25-75291	00	Rubber II	橡胶垫II	1		
13	G0U25-75301	00	Rubber III	橡胶垫III	8		
14	G0U25-75051	00	Bolt	塑料嵌件螺栓 M8x23	6		
15	A73E6-70401	00	Gas spring	气弹簧	2		
16	G27Z5-72221	01	Support	气弹簧座	2		
17	B4123-00008	00	Nut	螺母 M8	8	GB6170-86	GB6170-86
18	B5050-00008	00	Washer	垫圈 8	8	GB93-87	GB93-87
19	B5310-00008	00	Washer	垫圈 8	8	GB97.1-85	GB97.1-85
20	B1210-04012	00	Screw	螺钉 M4x12	6	GB818-85	GB818-85
21	B4123-00004	00	Nut	螺母 M4	4	GB6170-86	GB6170-86
22	H24C5-12612	03	Nut	柳螺母M8	6		
23	B0330-08025-X	00	Combined bolt	组合螺栓 M8x25	6	GB/T 9074.17-88	GB/T 9074.17-88
24	P32F5-73411	01	Sealing vertical bar	密封竖条(直气囊)	1		
25	A6S55-75021	00	Sealing strip	玻璃密封条(侧气囊)	1		
26	P32F5-73441	01	Trim strip	装饰条	1		
27	B5210-00006	00	Washer,lock	垫圈 6	4	GB96-85	GB96-85
28	B0330-06025	00	Bolt	螺栓 M6x25	4	GB5783-86	GB5783-86

KM915-70101U 00 Handle

KM915-70101U 00 转动把手

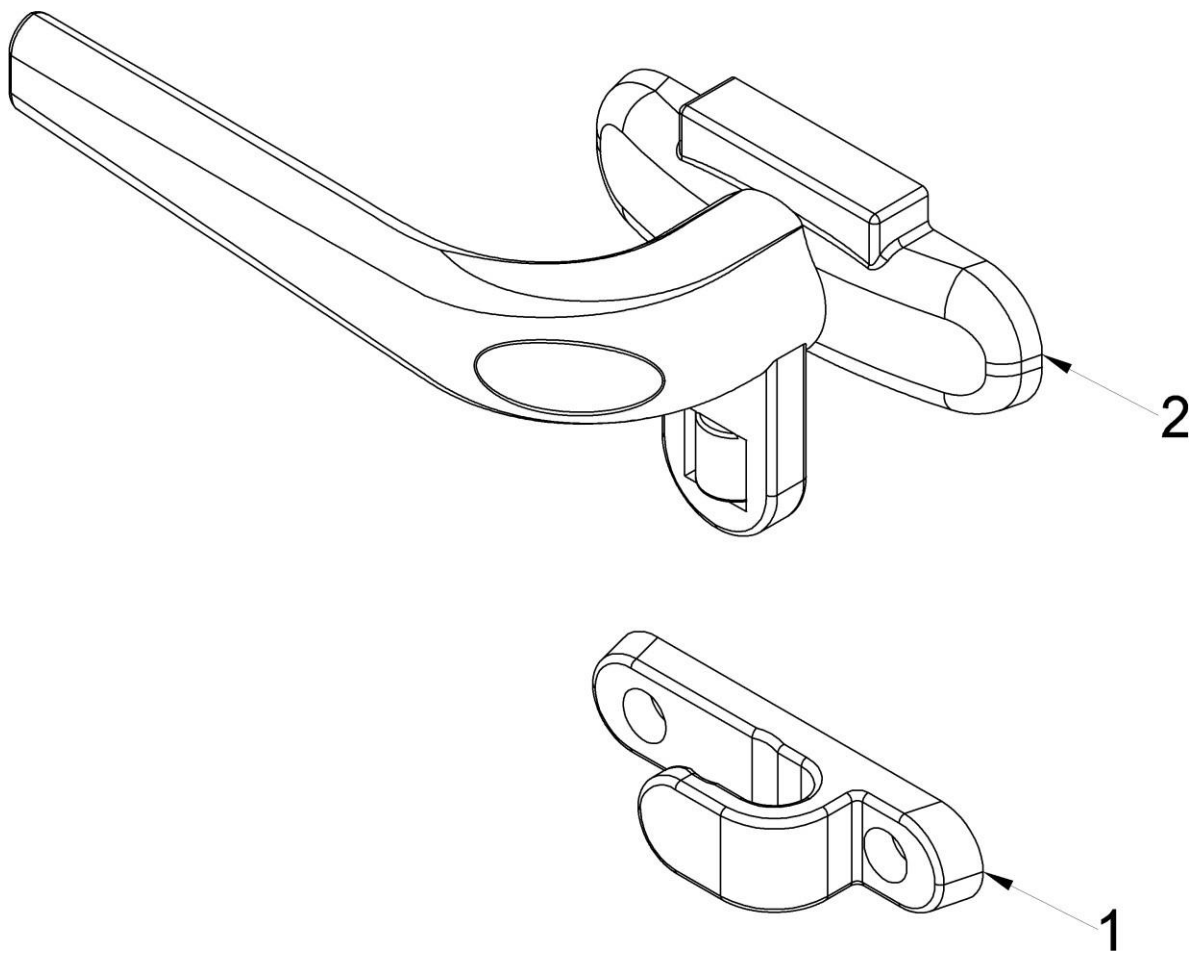

KM915-70101U 00 Handle

KM915-70101U 00 转动把手

序号 No.	零部件代号 Part No.	版本 Edition	名称 Part name		数量 Q'ty	备注 Remark	
1	KM915-73091U	00	Handle	把手主体	1		
2	KM915-73101U	00	Button	限位扣	1		

H43E5-71341 03 President of mirror installation

H43E5-71341 03 倒车镜安装总成

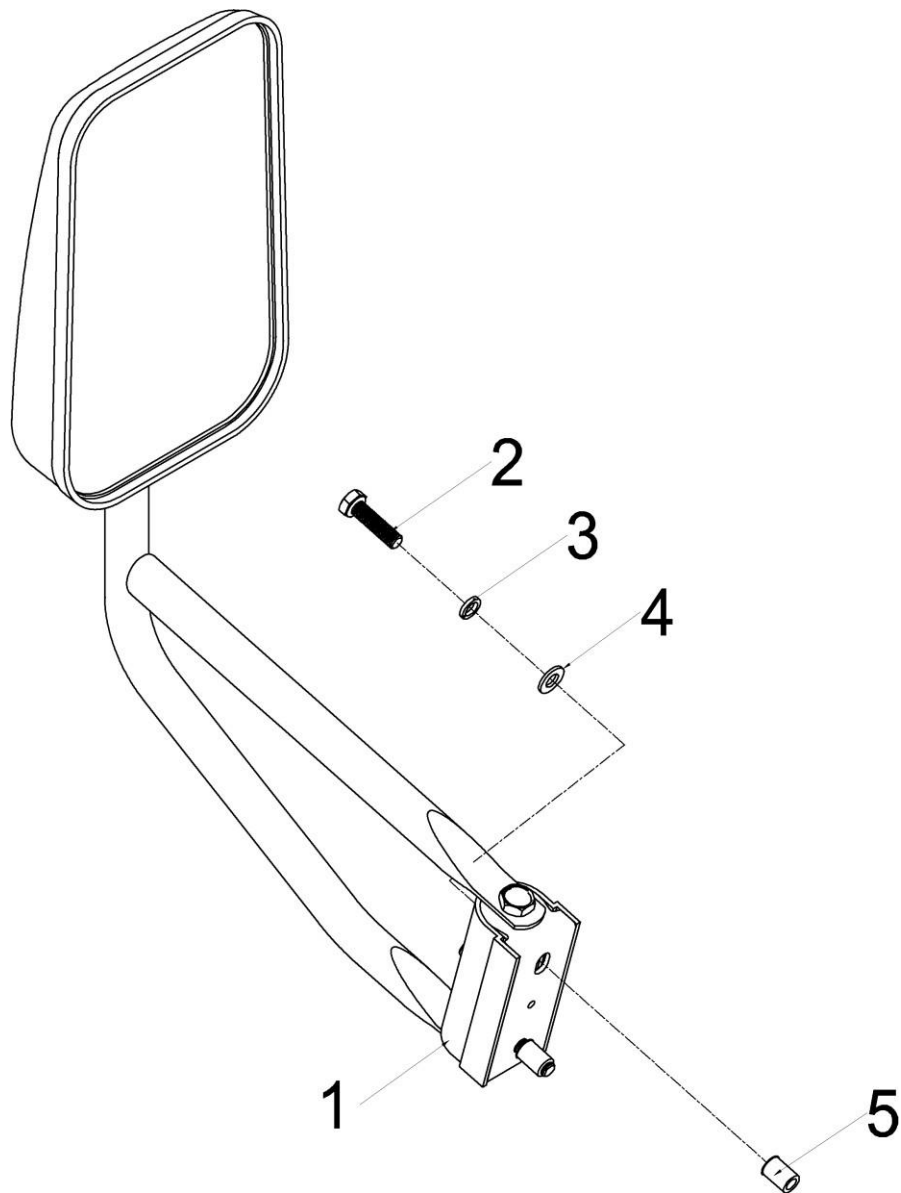

H43E5-71341 03 President of mirror installation

H43E5-71341 03 倒车镜安装总成

序号 No.	零部件代号 Part No.	版本 Edition	名称 Part name		数量 Q'ty	备注 Remark	
1	H43E5-75351	01	Back-mirror assembly	倒车镜总成	1		
2	B1210-08030	00	Screw	螺钉 M8x30	2	GB5783-86	GB5783-86
3	B5050-00008	00	Washer	垫圈 8	2	GB93-87	GB93-87
4	B5310-00008	00	Washer	垫圈 8	2	GB97.1-85	GB97.1-85
5	H24C5-12612	03	Nut	柳螺母 M8	2		

ABG75-70081 00 Dome light mounting

ABG75-70081 00 顶灯安装总成

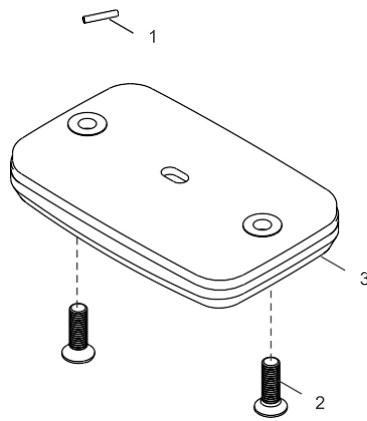

ABG75-70081 00 Dome light mounting

ABG75-70081 00 顶灯安装总成

序号 No.	零部件代号 Part No.	版本 Edition	名称 Part name		数量 Q'ty	备注 Remark	
1	ABG72-72211	00	Dome light transition line	顶灯过渡线	1		
2	B1310-05016	00	Screw	螺钉 M5x16	2	GB819-85	GB819-85
3	G0DP5-70301	00	Light	书写灯	1		

A7V95-70071 00 Fan mounting

A7V95-70071 00 电风扇安装总成

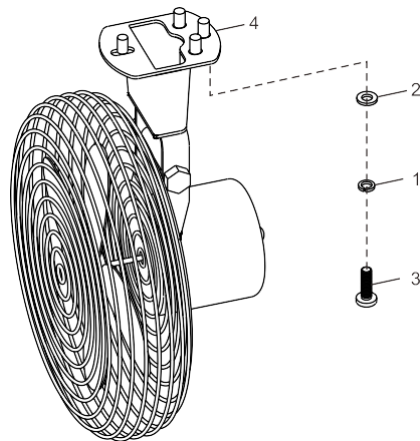

A7V95-70071 00 Fan mounting

A7V95-70071 00 电风扇安装总成

序号 No.	零部件代号 Part No.	版本 Edition	名称 Part name		数量 Q'ty	备注 Remark	
1	B5050-00006	00	Washer,lock	垫圈 6	2	GB93-87	GB93-87
2	B5310-00006	00	Washer,lock	垫圈 6	2	GB97.1-85	GB97.1-85
3	B1210-06020	00	Screw	螺钉 M6x20	2	GB818-85	GB818-85
4	K9FL5-73071	01	Fan	电风扇 (12V)	1		

A1755-70001KD 00 H4 overhead air conditioning cab assembly

A1755-70001KD 00 H4 顶置空调驾驶室总成

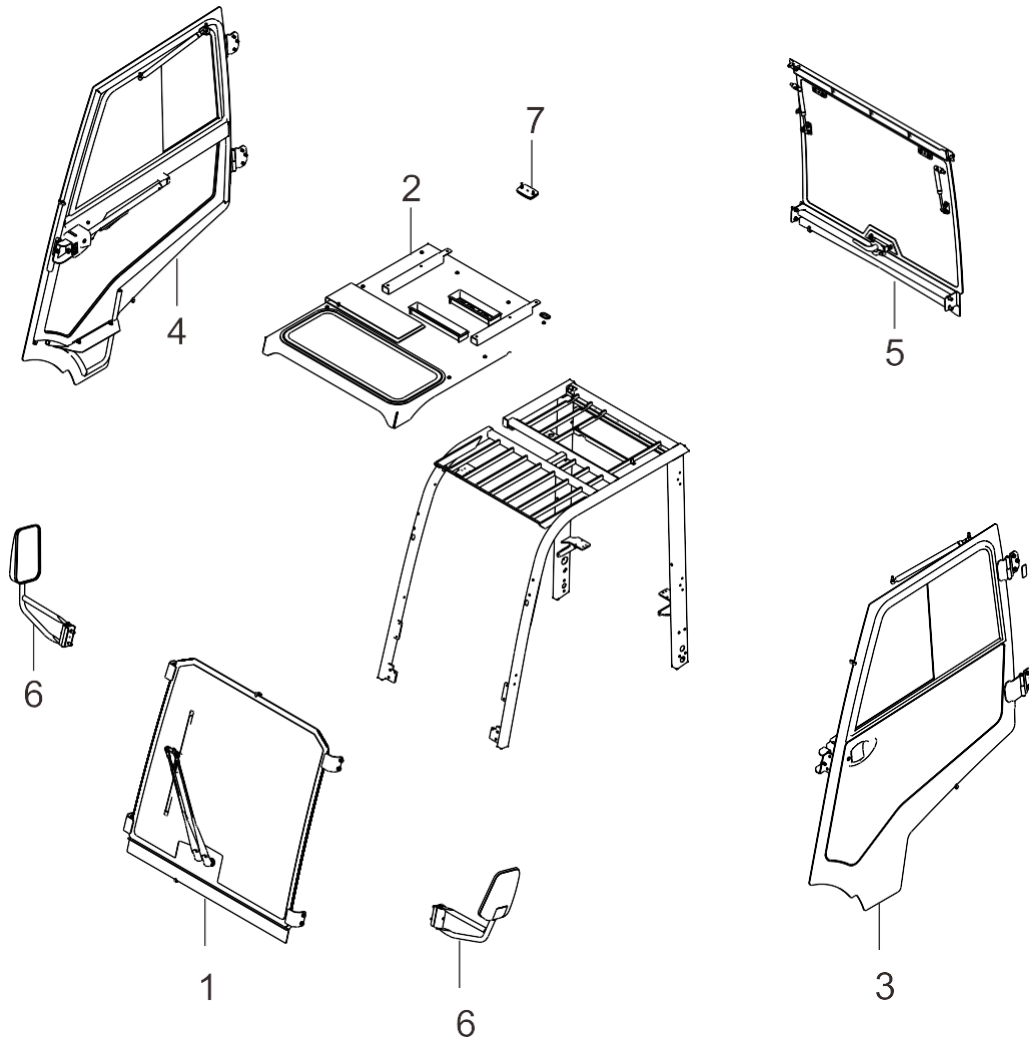

A1755-70001KD 00 H4 overhead air conditioning cab assembly

A1755-70001KD 00 H4 顶置空调驾驶室总成

序号 No.	零部件代号 Part No.	版本 Edition	名称 Part name		数量 Q'ty	备注 Remark	
1	A1755-70021	00	Front window ass'y	前窗总成	1		
2	A1755-70031KD	00	Coping assembly	顶部总成	1		
3	A1755-70041L	00	Side door ass'y	侧门总成(左)	1		
4	A1755-70041R	00	Side door ass'y	侧门总成(右)	1		
5	A1755-70051	00	Rear window ass'y	后窗总成	1		
6	H43E5-71341	03	President of mirror installation	倒车镜安装总成	2	X246-534	X246-534
7	ABG75-70081	00	Dome light mounting	顶灯安装总成	1		

A1755-70021 00 Front window ass'y

A1755-70021 00 前窗总成

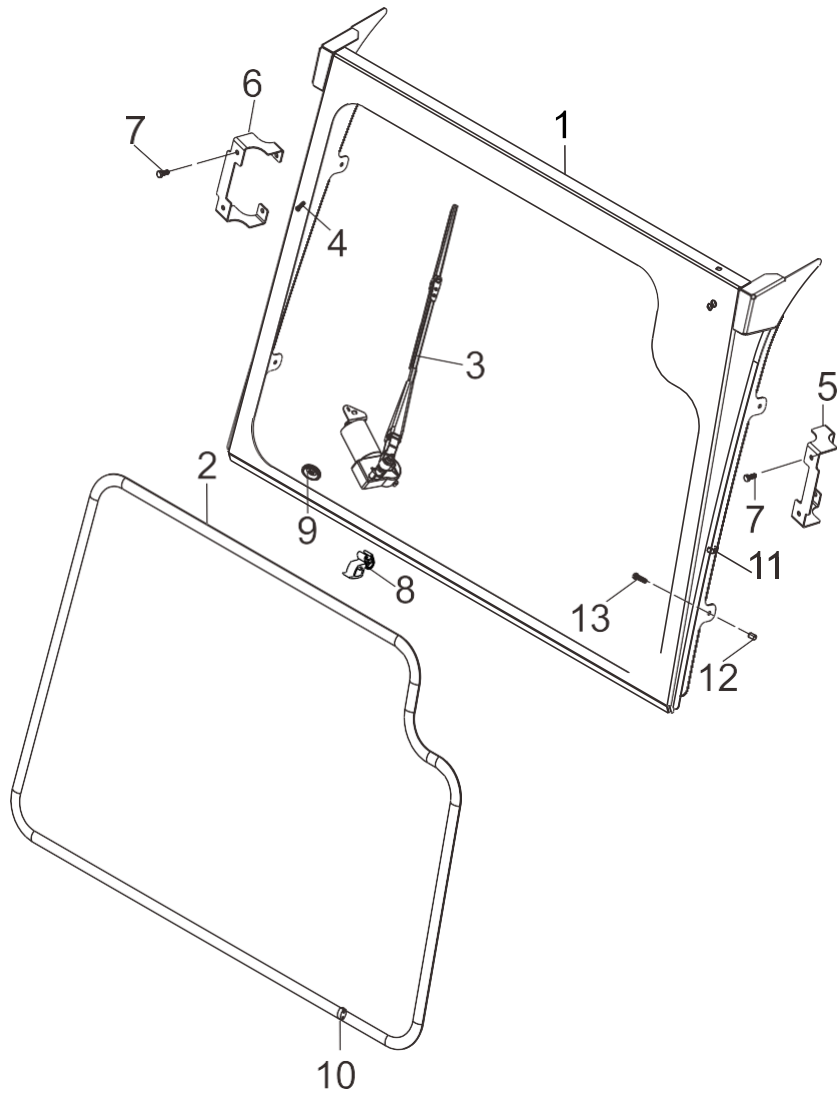

A1755- 0021 00 Front window ass'y

A1755-70021 00 前窗总成

序号 No.	零部件代号 Part No.	版本 Edition	名称 Part name		数量 Q'ty	备注 Remark	
1	A7V95-72061	00	Blade,wiper	雨刮器(双杆单刮 12V)	1		
2	A1755-72001	00	Glass	前窗玻璃	1		
3	A1755-70201	00	Blade,wiper	雨刮器	1		
4	H43E5-73021T	02	Front lamp column	前灯柱	4		
5	AF935-10271	01	Bracket L.H.	前大灯支架总成(左)	1		
6	AF935-10261	02	Bracket R.H.	前大灯支架总成(右)	1		
7	B0230-08065	00	Bolt M8x65	螺栓 M8x65	4	GB5782-86	GB5782-86
8	P32F5-73411	01	Sealing vertical bar	密封竖条(直气囊)	1		
9	A7T75-70401	00	injector	喷嘴	1		
10	JZX-70007	03	Sealing strip	玻璃密封条	1		
11	G0U25-76051	00	Seal	密封条(侧气囊)	2		
12	H24C5-12612	03	Nut	铆螺母M8	4		
13	B0330-08025-X	00	Combined bolt	组合螺栓 M8x25	4	GB/T 9074.17-88	GB/T 9074.17-88

A1755-70031KD 00 Coping assembly

A1755-70031KD 00 顶部总成

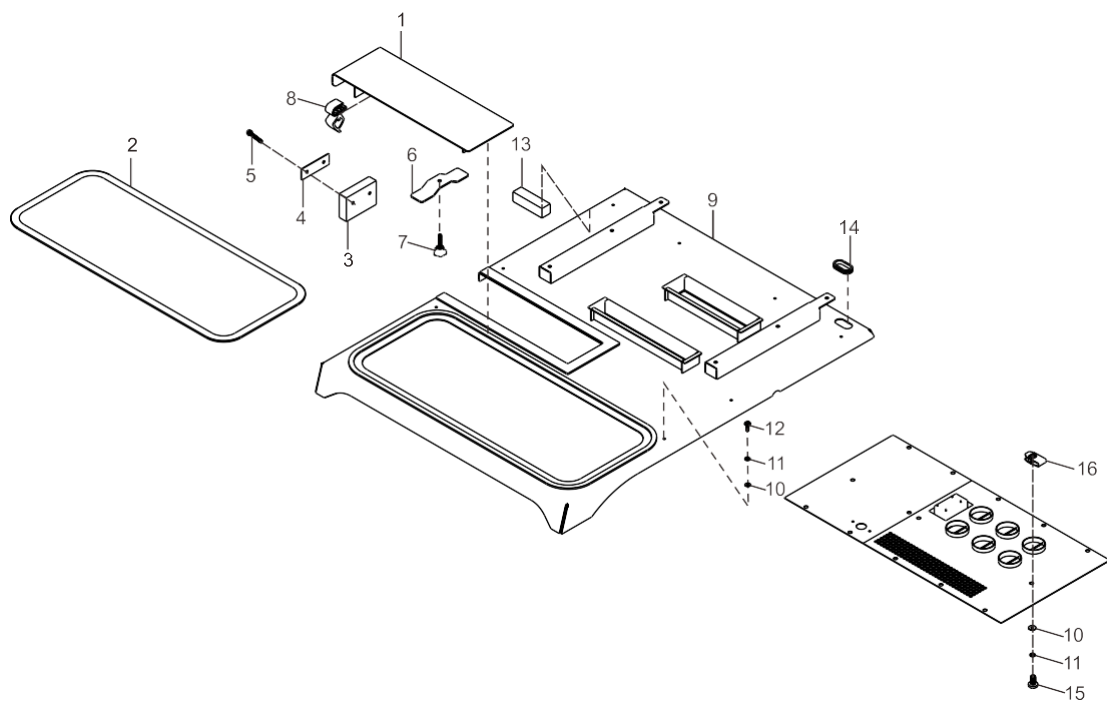

A1755-70031KD 00 Coping assembly

A1755-70031KD 00 顶部总成

序号 No.	零部件代号 Part No.	版本 Edition	名称 Part name		数量 Q'ty	备注 Remark	
1	A1755-70301	00	Lifting cover plate assembly	吊装盖板总成	1		
2	JH2000-0700P	01	Glass	顶窗玻璃	1	JH3-19P	JH3-19P
3	A1755-73021	00	Gasket plate	密封垫板	1		
4	A7V95-72361	00	Plate	垫板	1	X1949J-48	X1949J-48
5	B0330-08055-X	00	Combined outer hexagon bolt	组合外六角螺栓 M8x55	2	GB5783-86	GB5783-86
6	A7V95-72171	00	Septum board	勾板	1	X1949J-28	X1949J-28
7	A7V95-72181	00	Handle	五星把手 M8x45	1		
8	G0U25-76051	00	Seal	密封条(侧气囊)	1	L=1.6m	L=1.6m
9	A1755-70311KD	00	Coping jointing	顶部焊接总成	1		
10	B5210-00006	00	Washer,lock	垫圈 6	22	GB96-85	GB96-85
11	B5050-00006	00	Washer,lock	垫圈 6	22	GB93-87	GB93-87
12	B1710-6P332	00	Screw ST6.3x32	螺钉 ST6.3x32	8	GB845-85	GB845-85
13	P32F5-73031	01	Seal	橡塑密封条(CR 胶条)10x35	1	Outsourcing	外购
14	H43E2-43601	00	Rubber ring	出线胶圈	1		
15	B1210-06012	00	Screw	螺钉 M6x12	14	GB818-85	GB818-85
16	H43E5-75031	00	Nut	簧片螺母 M6	4		

A1755-70041L 00 Side door ass'y

A1755-70041L 00 侧门总成(左)

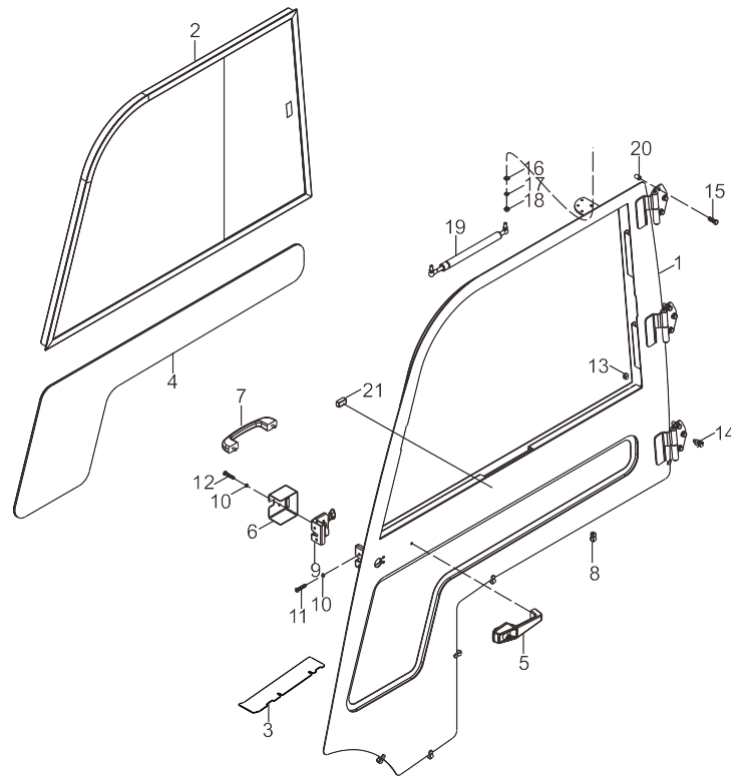

A1755-70041L 00 Side door ass'y

A1755-70041L 00 侧门总成(左)

序号 No.	零部件代号 Part No.	版本 Edition	名称 Part name		数量 Q'ty	备注 Remark	
1	A1755-70401L	00	Side door welded frame	侧门焊接框架	1		
2	A1755-70411L	00	Push-pull window	推拉窗	1		
3	A1755-74071L	00	Plate	下封板 (左)	1		
4	G0U25-74651L	00	Glass L.H.	左侧门玻璃	1		
5	DS502L	01	Side door lock assembly, L.H.	侧门锁总成(左)	1		
6	P62A5-72571L	03	Box L.H.	锁盒(左)	1		
7	Ja0308-0000B	02	Handle	小拉手	1		
8	JZX-70007	03	Sealing strip	玻璃密封条	1		
9	G0U25-70471NL	01	Pole,lock L.H.	锁柱总成 (左)	1		
10	B5050-00006	00	Washer,lock	垫圈 6	2	GB93-87	GB93-87
11	B1210-06035	00	Screw	螺钉 M6x35	2	GB818-85	GB818-85
12	B1210-06020	00	Screw	螺钉 M6x20	5	GB818-85	GB818-85
13	G0U25-76051	00	Seal	密封条(侧气囊)	1		
14	P32F5-73411	01	Sealing vertical bar	密封竖条(直气囊)	2		
15	B0330-08020-X	00	Combined bolt	组合螺栓 M8x20	8	GB/T 9074.17-88	GB/T 9074.17-88
16	B5310-00008	00	Washer	垫圈 8	3	GB97.1-85	GB97.1-85
17	B5050-00008	00	Washer	垫圈 8	3	GB93-87	GB93-87
18	B4123-00008	00	Nut	螺母 M8	3	GB6170-86	GB6170-86
19	A7BZ5-74351	01	Gas spring	气弹簧	1		
20	H24C5-12612	03	Nut	柳螺母M8	6		
21	6TY40-33-09	00	Plate	侧门二级开启提示标贴	1		

A1755-70041R 00 Side door ass'y

A1755-70041R 00 侧门总成(右)

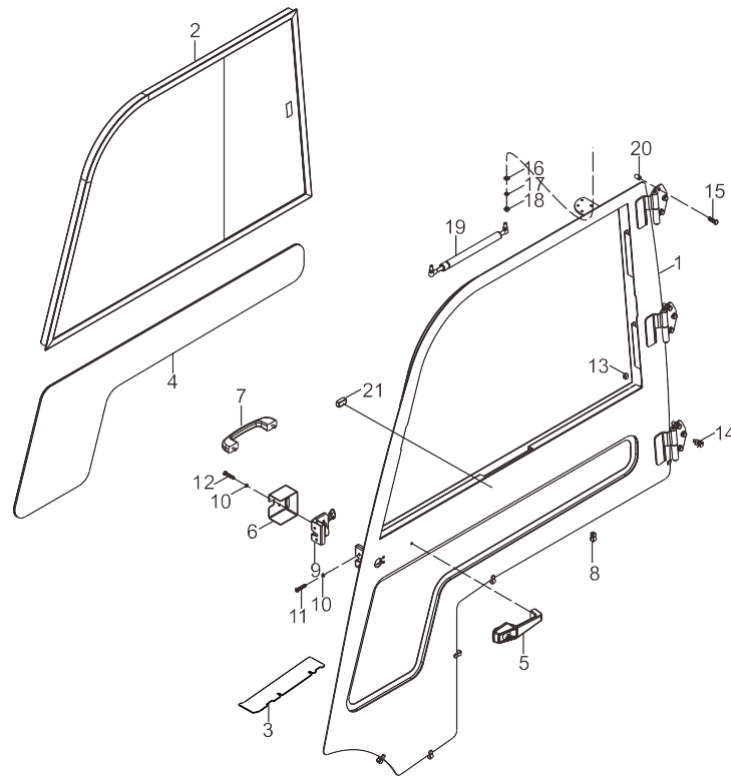

A1755-70041R 00 Side door ass'y

A1755-70041R 00 侧门总成(右)

序号 No.	零部件代号 Part No.	版本 Edition	名称 Part name		数量 Q'ty	备注 Remark	
1	A1755-70401R	00	Side door welding frame (right)	侧门焊接框架 (右)	1		
2	A1755-74071R	00	Plate	下封板 (右)	1		
3	A1755-70411R	00	Push-pull window	推拉窗 (右)	1		
4	JZX-70007	03	Sealing strip	玻璃密封条	1		
5	G0U25-74651R	00	Glass R.H.	右门下玻璃	1		
6	Ja0308-0000B	02	Handle	小拉手	1		
7	DS502R	01	Door lock assembly right	门锁总成 (右)	1		
8	B1210-06020	00	Screw	螺钉 M6x20	5	GB818-85	GB818-85
9	P62A5-72571R	02	Box R.H.	右锁盒	1		
10	B5050-00006	00	Washer,lock	垫圈 6	2	GB93-87	GB93-87
11	B1210-06035	00	Screw	螺钉 M6x35	2	GB818-85	GB818-85
12	6TY40-33-09	00	Plate	侧门二级开启提示标贴	1		
13	A7BZ5-74351	01	Gas spring	气弹簧	1		
14	H24C5-12612	03	Nut	铆螺母M8	6		
15	B0330-08025-X	00	Combined bolt	组合螺栓 M8x25	6	GB/T 9074.17-88	GB/T 9074.17-88
16	B5310-00008	00	Washer	垫圈 8	3	GB97.1-85	GB97.1-85
17	B5050-00008	00	Washer	垫圈 8	3	GB93-87	GB93-87
18	B4123-00008	00	Nut	螺母 M8	3	GB6170-86	GB6170-86
19	G0U25-76051	00	Seal	密封条(侧气囊)	1		
20	B0330-08020-X	00	Combined bolt	组合螺栓 M8x20	2		
21	G0U25-70471NR	01	Pole,lock R.H.	锁柱总成 (右)	1		
22	P32F5-73411	01	Sealing vertical bar	密封竖条(直气囊)	1		

A1755-70051 00 Rear window ass'y

A1755-70051 00 后窗总成

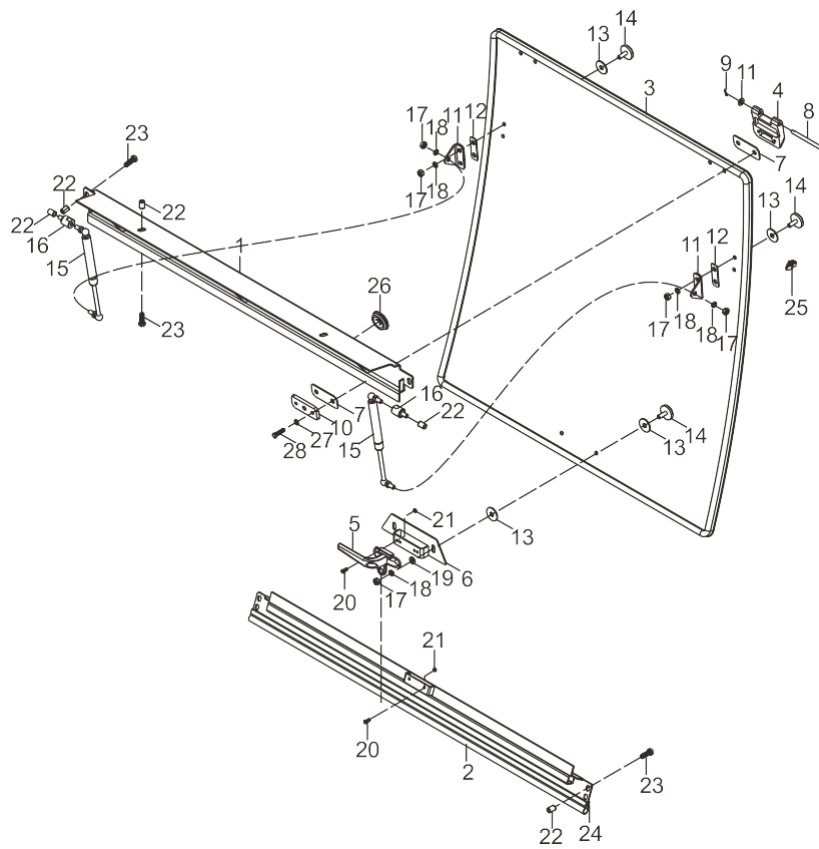

A1755- 00 1 00 Rear window ass'y

A1755-70051 00 后窗总成

序号 No.	零部件代号 Part No.	版本 Edition	名称 Part name		数量 Q'ty	备注 Remark	
1	A1755-70501	00	Crossbeam	后窗上横梁总成	1		
2	A1755-70511	00	Crossbeam	后窗下横梁总成	1		
3	A6V75-72341	00	Rear window	后窗玻璃	1		
4	G0U25-75001	00	Hinge joint	后窗铰链	2		
5	KM915-70101U	00	Handle	转动把手	1		
6	A7G55-70531	00	Jointing	玻璃衬板焊接	1		
7	G0U25-75281	00	Rubber I	橡胶垫I	4		
8	G0U25-75271	01	Shaft	轴	2		
9	B3010-02014	00	Pin 2x14	销 2x14	2	GB91-86	GB91-86
10	G0U25-75261	00	Plate	塑料垫板	2		
11	G0U25-75041	00	Bracket	气弹簧支座	2		
12	G0U25-75291	00	Rubber II	橡胶垫II	1		
13	G0U25-75301	00	Rubber III	橡胶垫III	8		
14	G0U25-75051	00	Bolt	塑料嵌件螺栓 M8x23	6		
15	A73E6-70401	00	Gas spring	气弹簧	2		
16	G27Z5-72221	01	Support	气弹簧座	2		
17	B4123-00008	00	Nut	螺母 M8	8	GB6170-86	GB6170-86
18	B5050-00008	00	Washer	垫圈 8	8	GB93-87	GB93-87
19	B5310-00008	00	Washer	垫圈 8	8	GB97.1-85	GB97.1-85
20	B1210-04012	00	Screw	螺钉 M4x12	6	GB818-85	GB818-85
21	B4123-00004	00	Nut	螺母 M4	4	GB6170-86	GB6170-86
22	H24C5-12612	03	Nut	柳螺母M8	6		
23	B0330-08025-X	00	Combined bolt	组合螺栓 M8x25	6	GB/T 9074.17-88	GB/T 9074.17-88
24	P32F5-73411	01	Sealing vertical bar	密封竖条(直气囊)	1		
25	A6S55-75021	00	Sealing strip	玻璃密封条(侧气囊)	1		
26	P32F5-73441	01	Trim strip	装饰条	1		
27	B5210-00006	00	Washer,lock	垫圈 6	4	GB96-85	GB96-85
28	B0330-06025	00	Bolt	螺栓 M6x25	4	GB5783-86	GB5783-86

KM915-70101U 00 Handle

KM915-70101U 00 转动把手

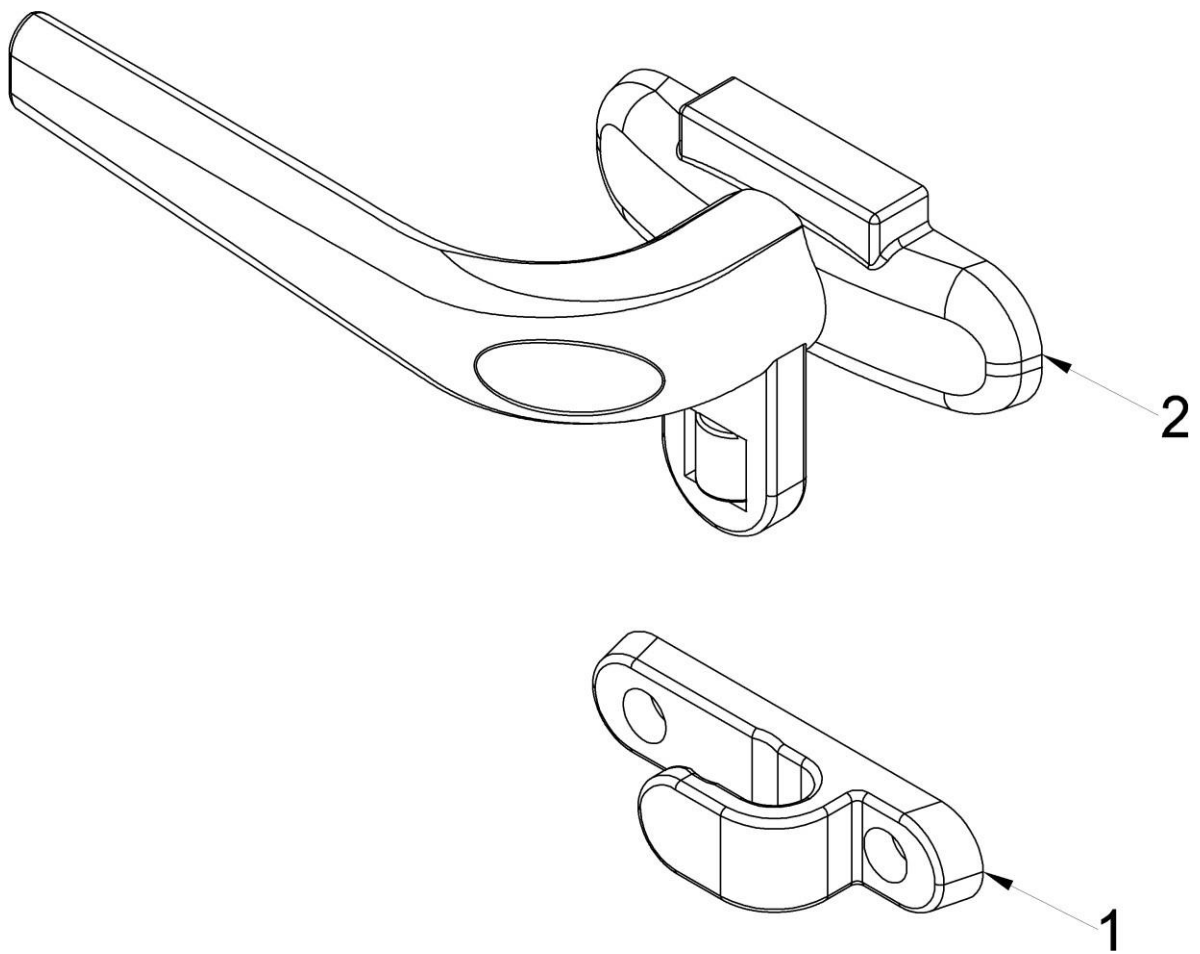

H43E5-71341 03 President of mirror installation

H43E5-71341 03 倒车镜安装总成

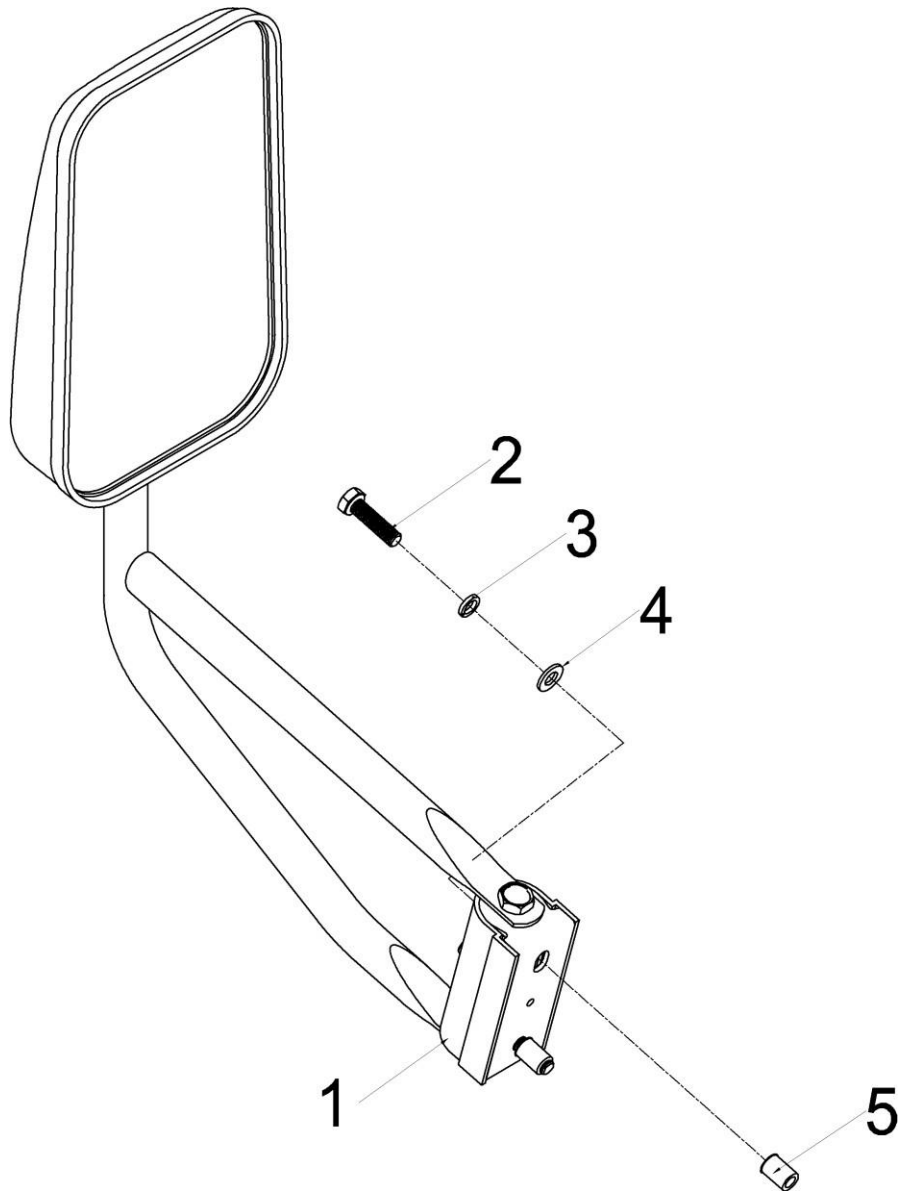

ABG75-70081 00 Dome light mounting

ABG75-70081 00 顶灯安装总成

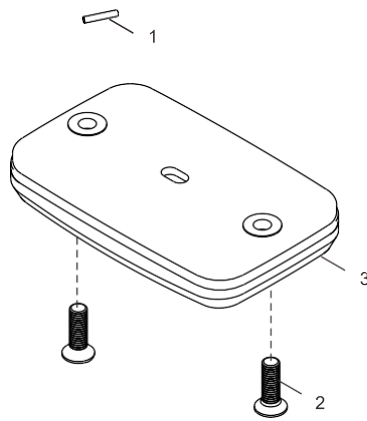

HRA1755901 00 H4 series windshield assembly

HRA1755901 00 H4 系列挡风类总成

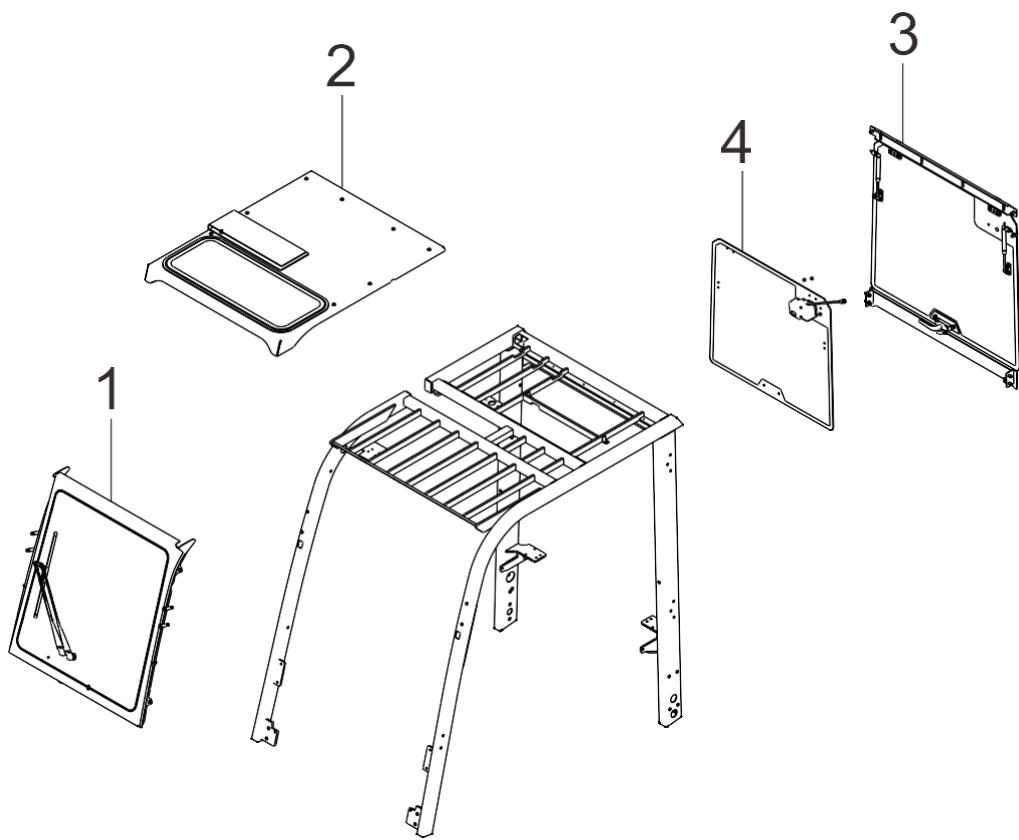

A1755-70021 00 Front window ass'y

A1755-70021 00 前窗总成

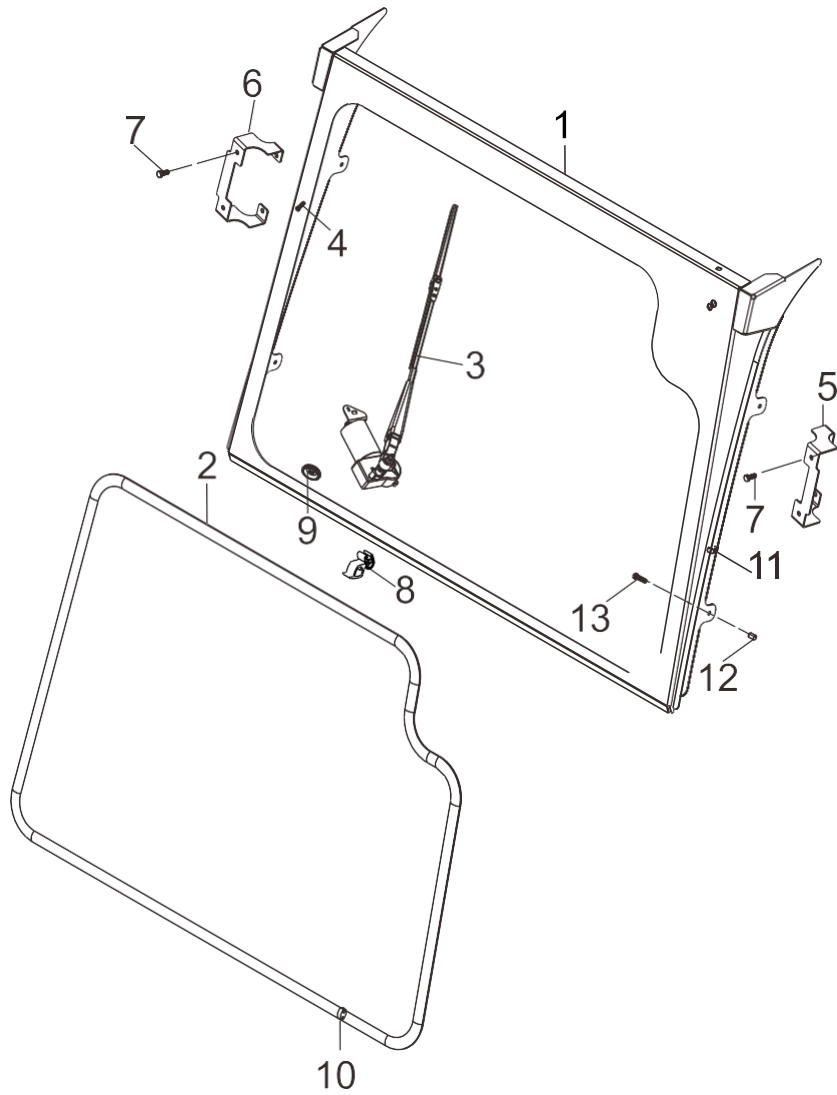

A1755-70031 00 Coping assembly

A1755-70031 00 顶部总成

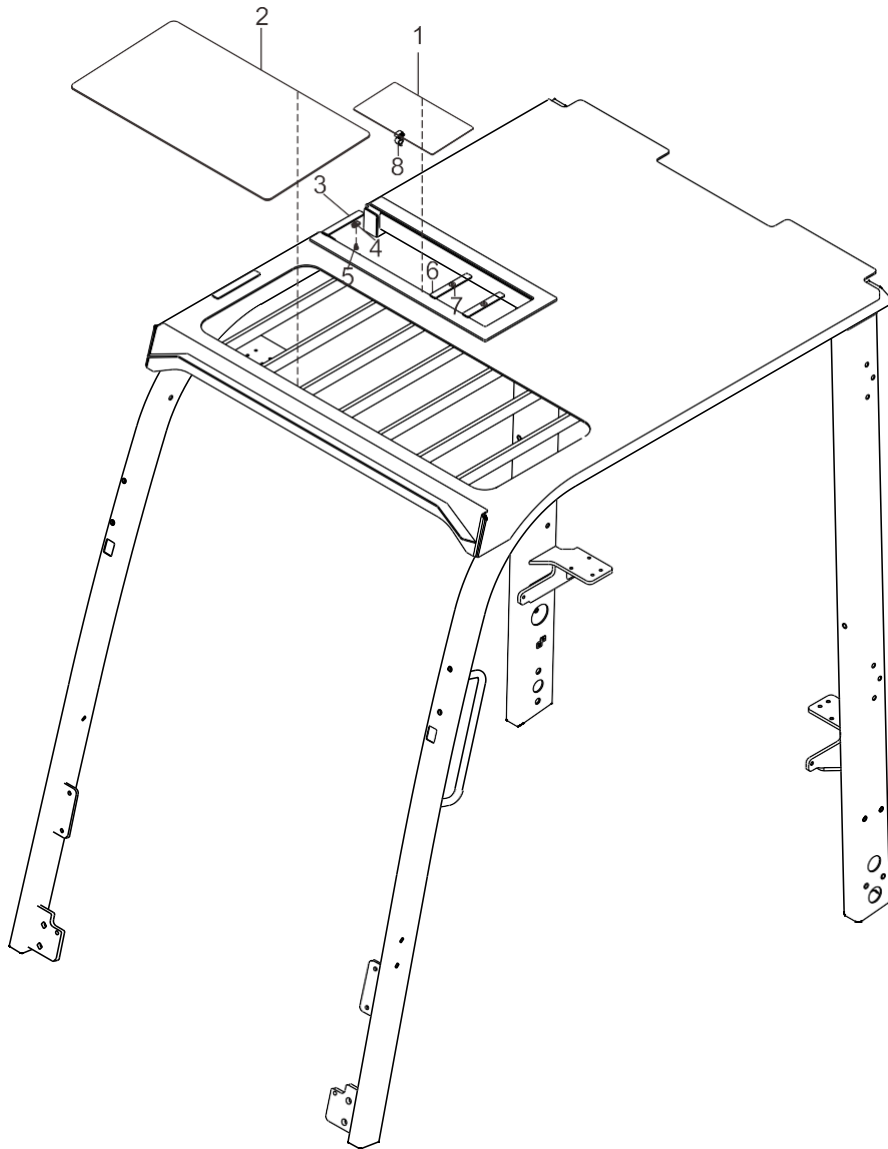

A1755-70051A 00 Rear window ass'y

A1755-70051A 00 后窗总成

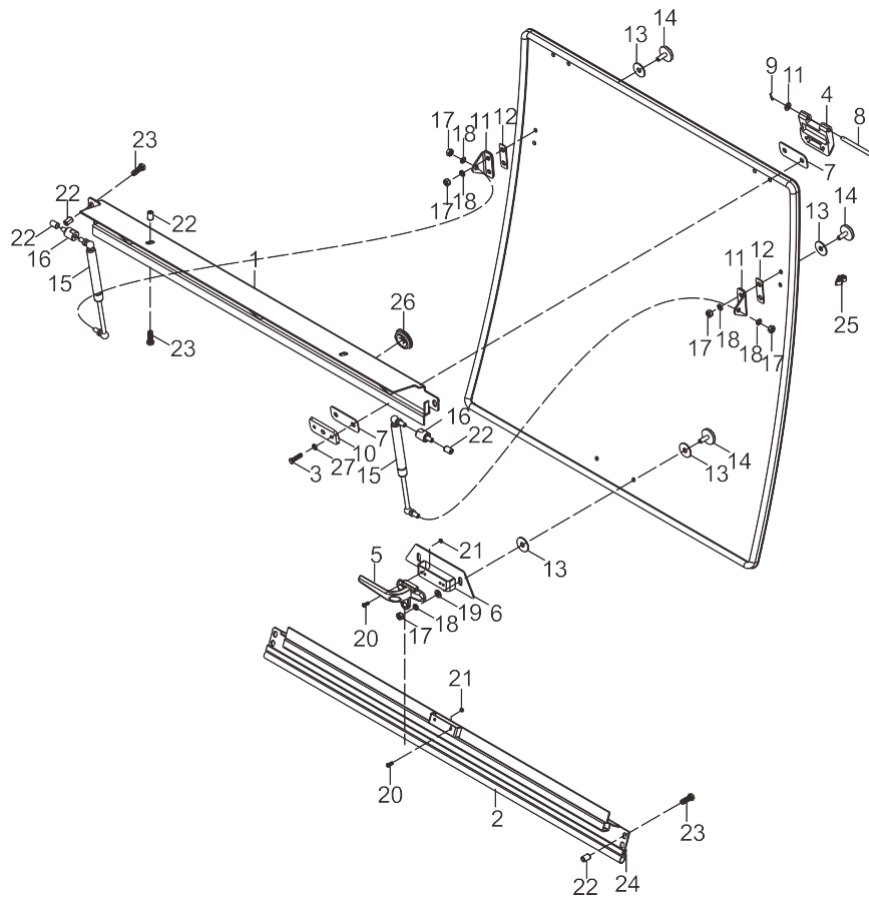

A1755- 00 1A 00 Rear window ass'y

A1755-70051A 00 后窗总成

序号 No.	零部件代号 Part No.	版本 Edition	名称 Part name		数量 Q'ty	备注 Remark	
1	A1755-70501	00	Crossbeam	后窗上横梁总成	1		
2	A1755-70511	00	Crossbeam	后窗下横梁总成	1		
3	B0330-06025	00	Bolt	螺栓 M6x25	4	GB5783-86	GB5783-86
4	G0U25-75001	00	Hinge joint	后窗铰链	2	X1602-232	X1602-232
5	KM915-70101U	00	Handle	转动把手	1		
6	A7G55-70531	00	Jointing	玻璃衬板焊接	1		
7	G0U25-75281	00	Rubber I	橡胶垫I	4	X1602-256	X1602-256
8	G0U25-75271	01	Shaft	轴	2	X1602-255	X1602-255
9	B3010-02014	00	Pin 2x14	销 2x14	2	GB91-86	GB91-86
10	G0U25-75261	00	Plate	塑料垫板	2	X1602-254	X1602-254
11	G0U25-75041	00	Bracket	气弹簧支座	2	X1602-236	X1602-236
12	G0U25-75291	00	Rubber II	橡胶垫II	1	X1602-257	X1602-257
13	G0U25-75301	00	Rubber III	橡胶垫III	8	X1602-258	X1602-258
14	G0U25-75051	00	Bolt	塑料嵌件螺栓 M8x23	6		
15	A73E6-70401	00	Gas spring	气弹簧	2	J370-5G7Q	J370-5G7Q
16	G27Z5-72221	01	Support	气弹簧座	2	X630-230	X630-230
17	B4123-00008	00	Nut	螺母 M8	8	GB6170-86	GB6170-86
18	B5050-00008	00	Washer	垫圈 8	8	GB93-87	GB93-87
19	B5310-00008	00	Washer	垫圈 8	8	GB97.1-85	GB97.1-85
20	B1210-04012	00	Screw	螺钉 M4x12	6	GB818-85	GB818-85
21	B4123-00004	00	Nut	螺母 M4	4	GB6170-86	GB6170-86
22	H24C5-12612	03	Nut	柳螺母M8	6		
23	B0330-08025-X	00	Combined bolt	组合螺栓 M8x25	6	GB/T 9074.17-88	GB/T 9074.17-88
24	P32F5-73411	01	Sealing vertical bar	密封竖条(直气囊)	1	L=0.95m	L=0.95m
25	A6S55-75021	00	Sealing strip	玻璃密封条(侧气囊)	1	L=3.7m	L=3.7m
26	P32F5-73441	01	Trim strip	装饰条	1	L=0.9m	L=0.9m
27	B5210-00006	00	Washer,lock	垫圈 6	4	GB96-85	GB96-85

KM915-70101U 00 Handle

KM915-70101U 00 转动把手

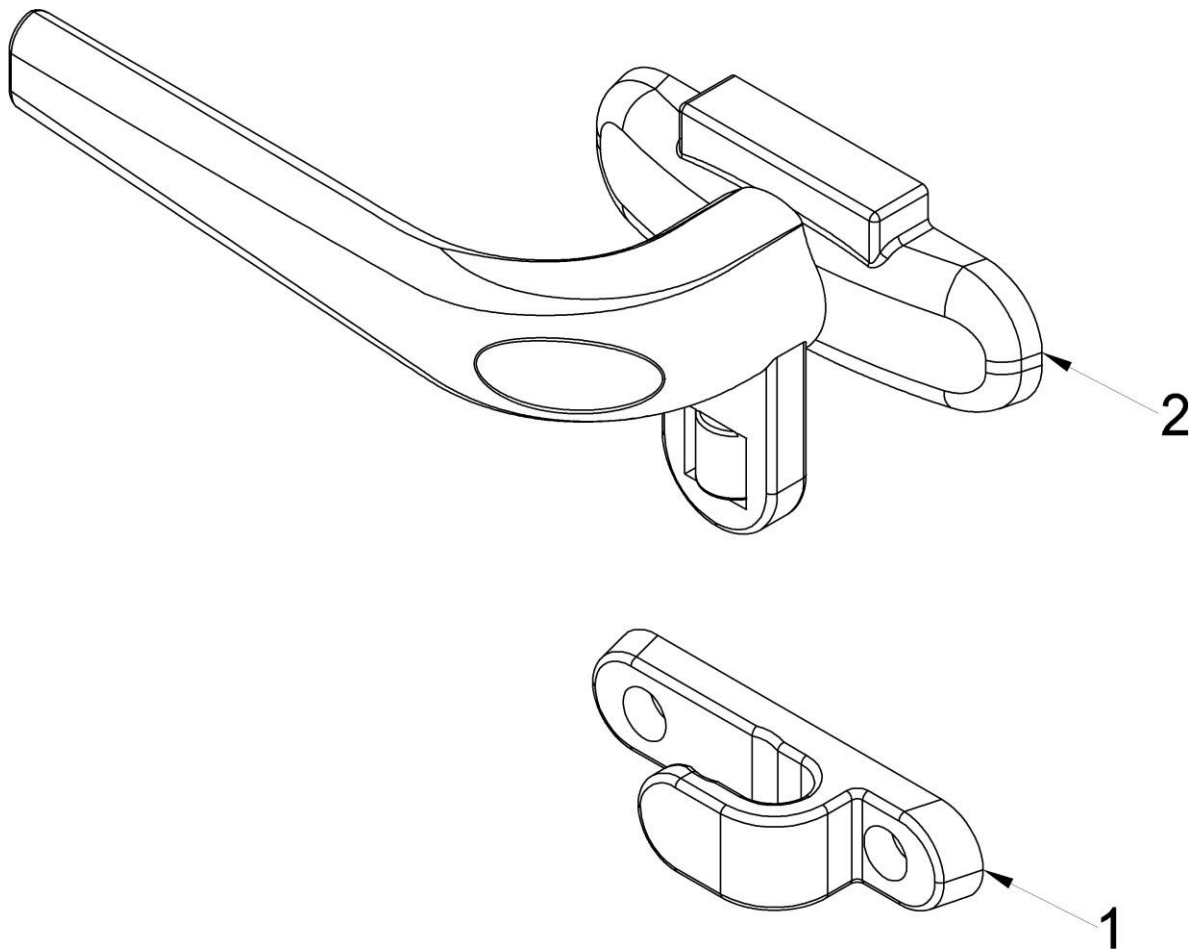

A1755-70091 00 Wind shield accessories

A1755-70091 00 挡风类附件

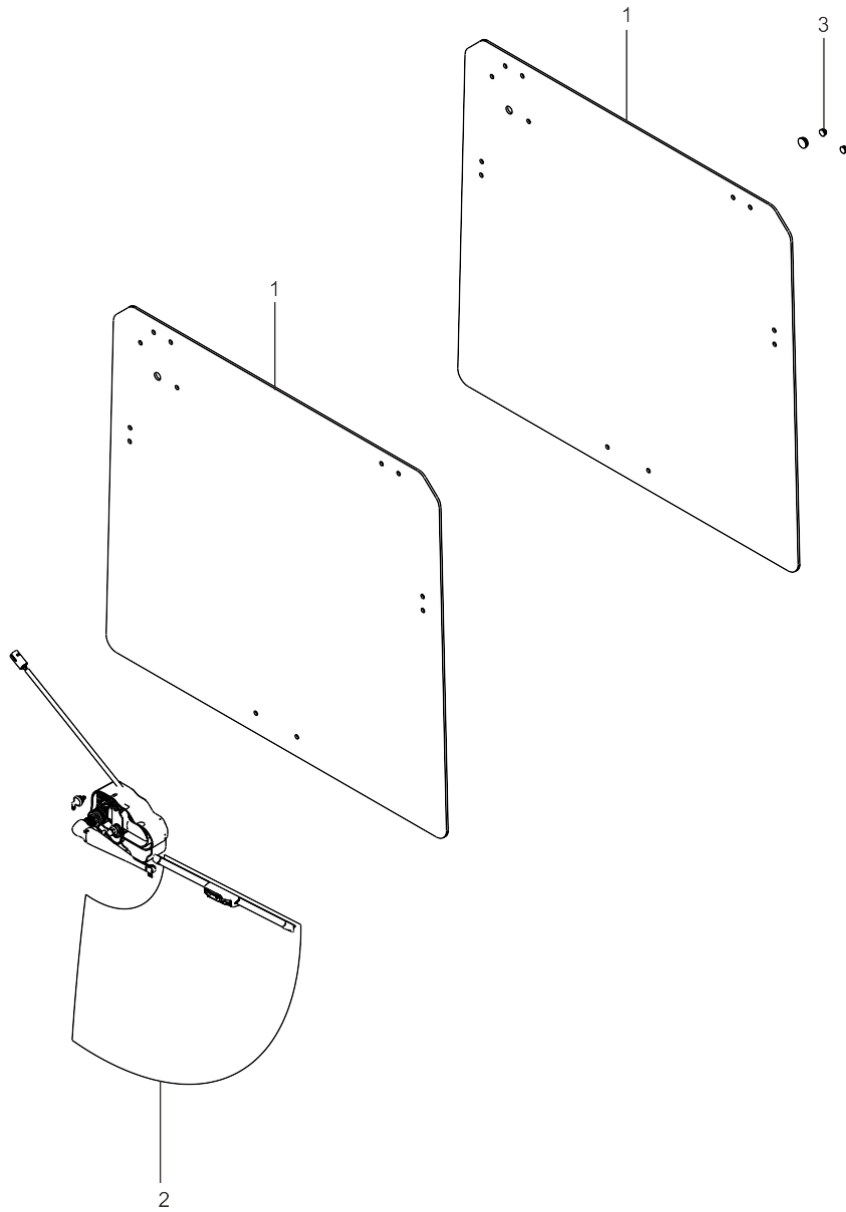

HRA1751301 01 Fire extinguisher assembly

HRA1751301 01 灭火器总成

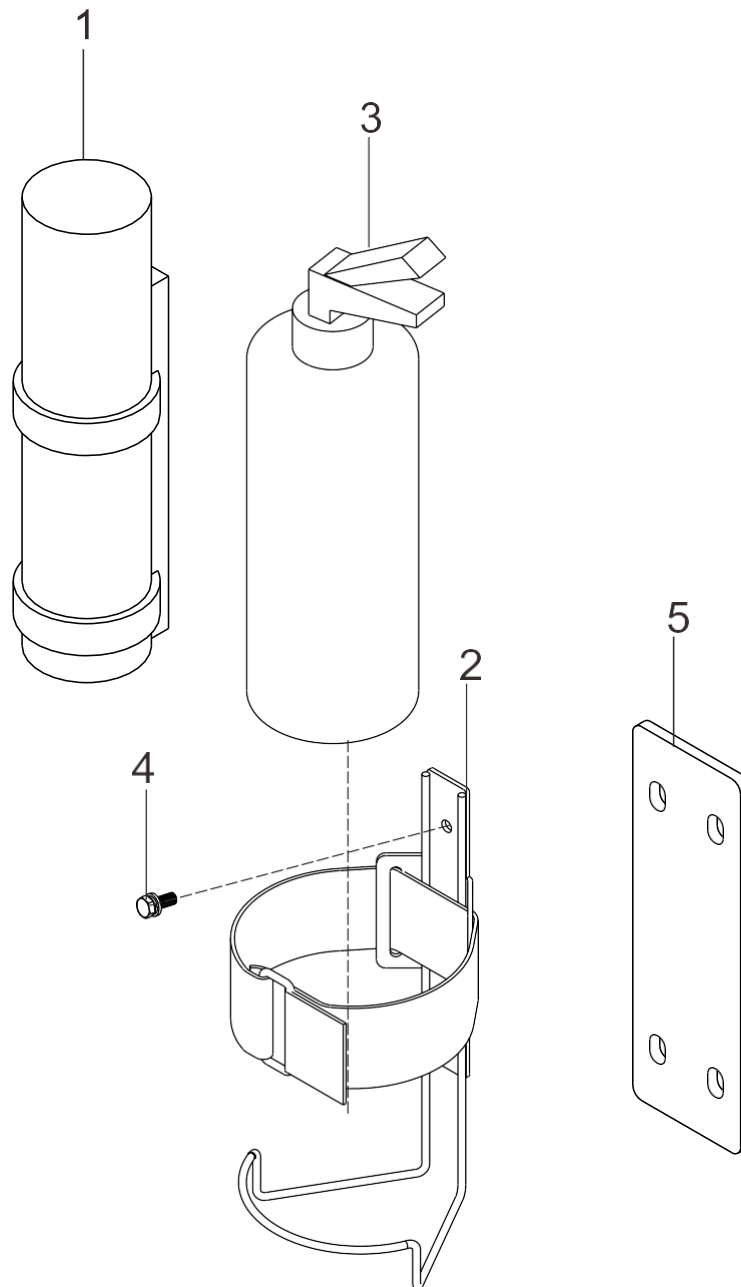

E19S5-10021GJ 00 Bracket

E19S5-10021GJ 00 灭火器支架总成

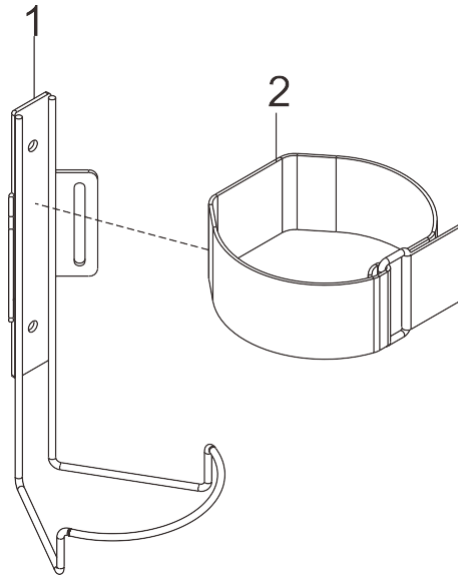

E19S5-10021GJ 00 Bracket

E19S5-10021GJ 00 灭火器支架总成

序号 No.	零部件代号 Part No.	版本 Edition	名称 Part name		数量 Q'ty	备注 Remark	
1	E19S5-10301GJ	01	Bracket	灭火器支架	1		
2	E19S5-12031	00	Velcro	魔术贴	1		

E19S5-10021A 00 Bracket

E19S5-10021A 00 灭火器支架总成

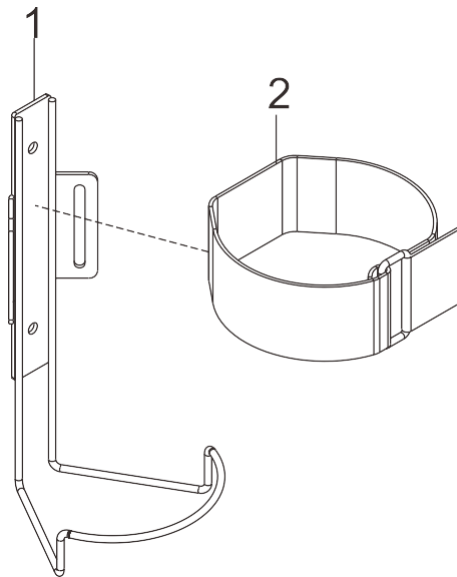

MFZL2-ABC 00

MFZL2-ABC 00 灭火器 ABC 干粉

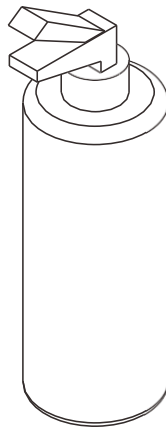

A22A0-00021 00 Backup mirror

A22A0-00021 00 倒车镜

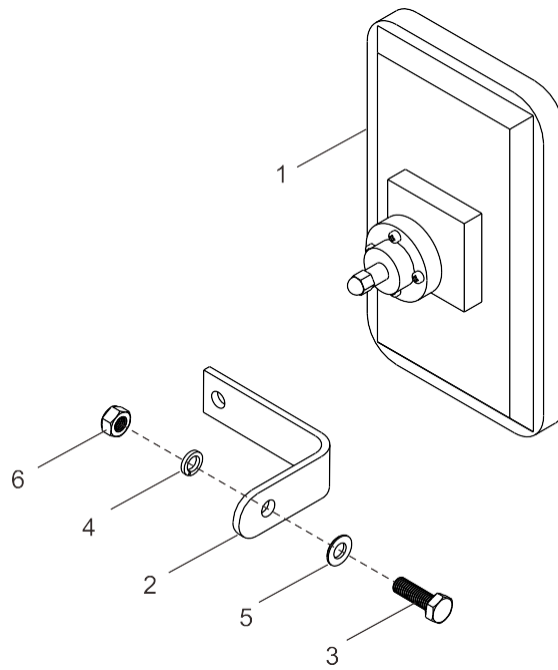

A22A0-00021 00 Backup mirror

A22A0-00021 00 倒车镜

序号 No.	零部件代号 Part No.	版本 Edition	名称 Part name		数量 Q'ty	备注 Remark	
1	A22A0-02021	00	Back-mirror assembly	倒车镜总成	1		
2	A22A0-02011	04	Bracket	倒车镜支架	1		
3	B0330-08025	00	Bolt	螺栓 M8x25	1	GB5783-86	GB5783-86
4	B5050-00008	00	Washer	垫圈 8	1	GB93-87	GB93-87
5	B5410-00008	00	Washer	垫圈 8	1	GB97.2-85	GB97.2-85
6	B4123-00008	00	Nut	螺母 M8	1	GB6170-86	GB6170-86

A1757-60001 04 Hydraulic pipeline system

A1757-60001 04 液压管路系统

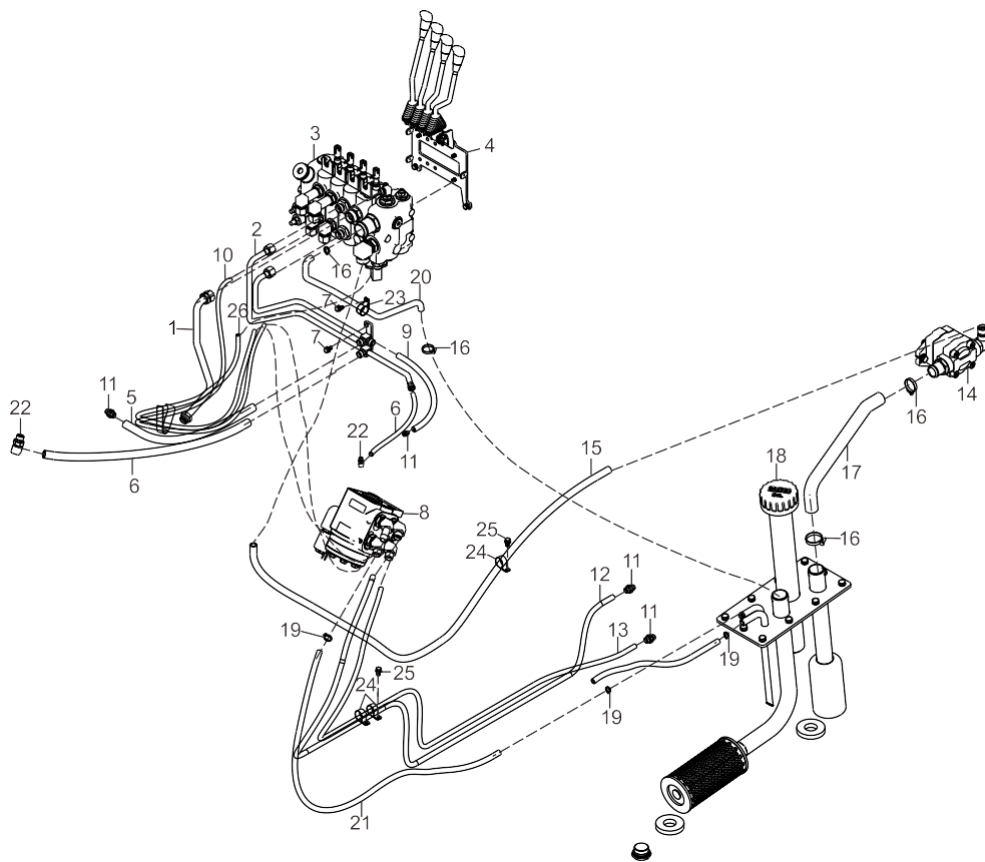

A1757-60001 04 Hydraulic pipeline system

A1757-60001 04 液压管路系统

序号 No.	零部件代号 Part No.	版本 Edition	名称 Part name		数量 Q'ty	备注 Remark	
1	A1757-60231B	00	Steel ass'y	起升过渡钢管总成	1	2-3.8 t	2-3.8t 用
1	A1757-60232	00	Steel ass'y	起升过渡钢管总成	1	1.5- Small two is useless	1.5-小 2t 用
2	A1757-60211	02	Tilt steel tube	倾斜钢管总成	1		
3	HRA1757301	02	Control valve	多路阀总成	1		
4	HRA1757401	01	Multiple valve control	多路阀操纵总成	1		
5	Z9701-0803714	00	Hose H.P. 8lx370	高压胶管 8lx370	1	2-3.8 t	2-3.8t 用
5	Z9701-0803514	00	High pressure hose,8lx350	高压胶管 8lx350	1	1.5- Small two is useless	1.5-小 2t 用
6	Z9701-0805414	00	Hose H.P. 8lx540	高压胶管 8lx540	2	2-3.8 t	2-3.8t 用
6	Z9701-0804814	00	High pressure hose, Φ 1X4 0	高压胶管, Φ 8lx480	2	1.5- Small two is useless	1.5-小 2t 用
7	B0330-08016-X	00	Combined bolt	组合螺栓 M8x16	2	GB/T 9074.17-88	GB/T 9074.17-88
8	HRABG77601	00	Steering gear mounting assembly	转向器安装总成	1		
9	Z9701- 0804814L07	00	Hose H.P. 8lx480	高压胶管 8lx480	1	2-3.8 t	2-3.8t 用
9	Z9701- 0804614L07	00	High pressure hose 8lx460,90°	高压胶管 8lx460,90°	1	1.5- Small two is useless	1.5-小 2t 用
10	Z9701- 0617112V04	00	Hose H.P. 6lx1710	高压胶管 6lx1710	1		
11	JT6021-16001LOR	01	Straight joint	直通接头	4	M16x1.5- M16x1.5	M16x1.5- M16x1.5
12	Z9701-0827014	00	Hose H.P. 8lx2700	高压胶管 8lx2700	1	3-3.8t	3-3.8t 用
12	Z9701-0826014	00	Hose H.P. 8lx2600	高压胶管 8lx2600	1	2-2.5 t	2-2.5t 用
12	Z9701-0824614	00	Hose H.P.	高压胶管(EN857)	1	1.5- Small two is useless	1.5-小 2t 用
13	Z9701-0826714	00	Hose H.P. 8lx2670	高压胶管 8lx2670	1	3-3.8t	3-3.8t 用
13	Z9701-0825714	00	Hose H.P. 8lx2570	高压胶管 8lx2570	1	2-2.5 t	2-2.5t 用
13	Z9701-0824314	00	Hose H.P.	高压胶管	1	1.5- Small two is useless	1.5-小 2t 用
14	A1757-60201	02	Gear pump assembly	齿轮泵总成	1		
15	Z9702- 1608024L35	00	Hose H.P. 16llx800	高压胶管 16llx800	1	Lithium battery,2- 3.8t	锂电池,2- 3.8t 用
15	Z9702- 1622224L08	00	Hose H.P.	高压胶管	1	3-3.8t	3-3.8t 用
15	Z9702- 1619124L08	00	Hose H.P. 16llx1910	高压胶管 16llx1910	1	2-2.5 t	2-2.5t 用
15	Z9702- 1618624L08	00	High Pressure Hose, φ1 ix 1 0	高压胶管, Φ 16llx1860	1	1.5- Small two is useless	1.5-小 2t 用
16	Z4592-32050	00	German type hose hoops	德式喉箍 32~50	4		
17	A1827-62021	01	Oil suction hose	吸油胶管	1	3-3.8t	3-3.8t 用

A1757-60001 04 Hydraulic pipeline system

A1757-60001 04 液压管路系统

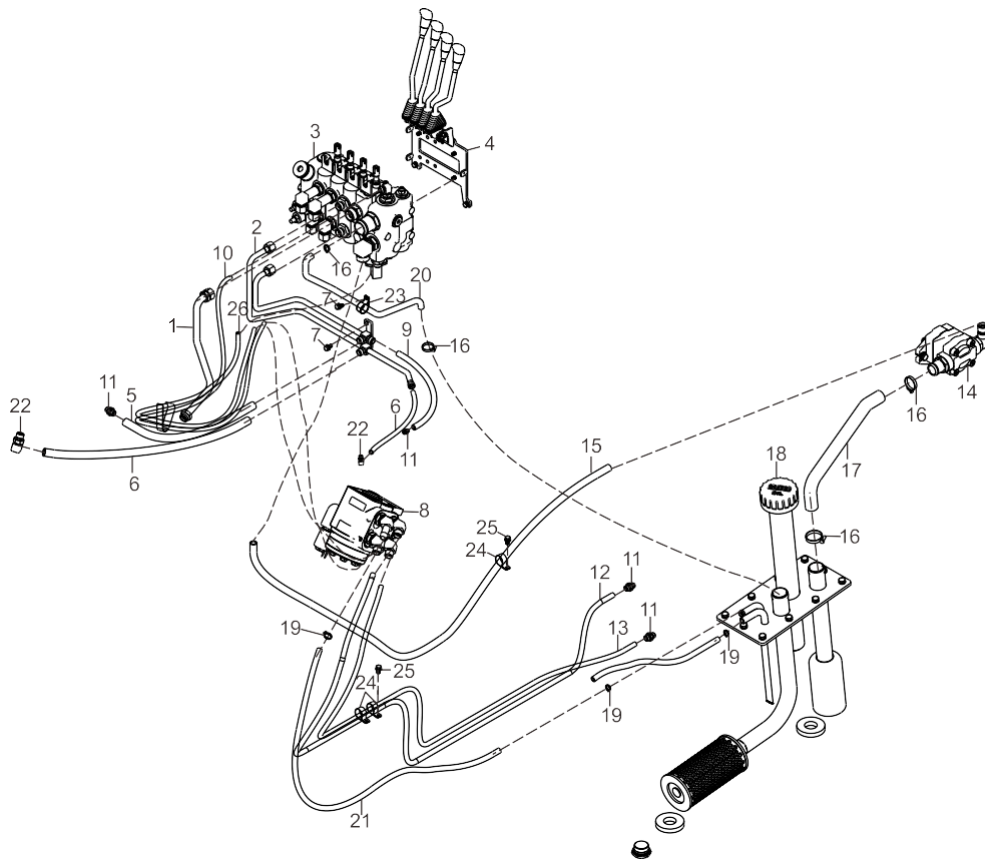

A1757-60001 04 Hydraulic pipeline system							
A1757-60001 04 液压管路系统							
序号 No.	零部件代号 Part No.	版本 Edition	名称 Part name		数量 Q'ty	备注 Remark	
17	A1757-62021	01	Oil suction hose	吸油胶管	1	2-2.5 t	2-2.5t 用
17	A1677-62021	01	Oil suction hose	吸油胶管	1	1.5- Small two is useless	1.5-小 2t 用
18	A1757-50001	02	Hydraulic fluid chamber	液压油箱附件总成	1		
19	Z4592-19029	00	Clamp 19~29	德式喉箍 19~29	3		
20	A1827-62031	01	Multi way valve return pipe	多路阀回油管	1	3-3.8t	3-3.8t 用
20	A1757-62031	00	Multi way valve return pipe	多路阀回油管	1	1.5-2.5t	1.5-2.5t 用
21	Z7300-13173	00	Rubber hose φ13x1 30	胶管 φ 13x1730	1	3-3.8t	3-3.8t 用
21	Z7300-13150	00	Hose L.P.	低压胶管 φ 13x1500	1	1.5-2.5t	1.5-2.5t 用
22	JT6022-16001LOR	00	Right angle joint	直角接头	2	2-3.8 t	2-3.8t 用
22	JT7022-14161LOR	00	Right angle joint	直角接头	2	1.5- Small two is useless	1.5-小 2t 用
23	ZF1A8-02071	01	Fixed clamp	固定管卡	1		
24	D1252-1116	00	Clip	线卡	3		
25	B0330-06016-X	00	Combined bolt	组合螺栓 M6×16	3	GB5783,GB 93,GB97.1	GB5783,GB 93,GB97.1
26	Z9701-0815314	00	Hose H.P. 8lx1530	高压胶管 8lx1530	1		

HRABG77601 00 Steering gear mounting assembly

HRABG77601 00 转向器安装总成

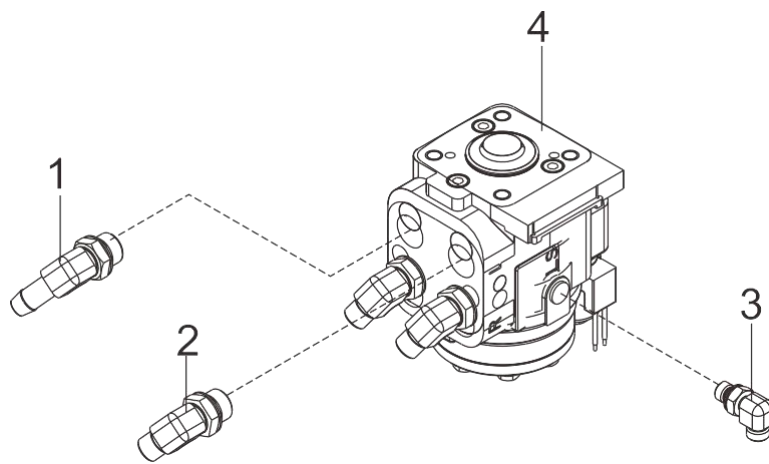

HRABG77601 00 Steering gear mounting assembly

HRABG77601 00 转向器安装总成

序号 No.	零部件代号 Part No.	版本 Edition	名称 Part name		数量 Q'ty	备注 Remark	
1	H1M57-60251	01	Elbow	60 度接头	1		
2	JT6023-20001LOR	00	Elbow	60 度接头	3	Metric	公制用
2	E1M57-60241	01	Elbow	60 度接头	3	SAE	美制用
3	HRG7B37602	00	Right angle joint	直角接头	1	G7B37-63501, Metric	G7B37-63501,公制用
3	JT8022-96091	02	Right angle joint	直角接头	1	SAE	美制用
4	G2Q34-10021	00	Steering unit	转向器	1	2-3.8t common steering	2-3.8t 普通转向用
4	G2Q34-10031	00	Steering unit	转向器	1	1.5-small 2t common steering	1.5-小 2t 普通转向用
4	GQ254-10111	00	Synchronous steering gear	同步转向器	1	2-3.8t Synchronization steering	2-3.8t 同步转向

--	--	--	--	--	--	--	--

HRA1755101 01 Roof guard assembly

HRA1755101 01 护顶架总成

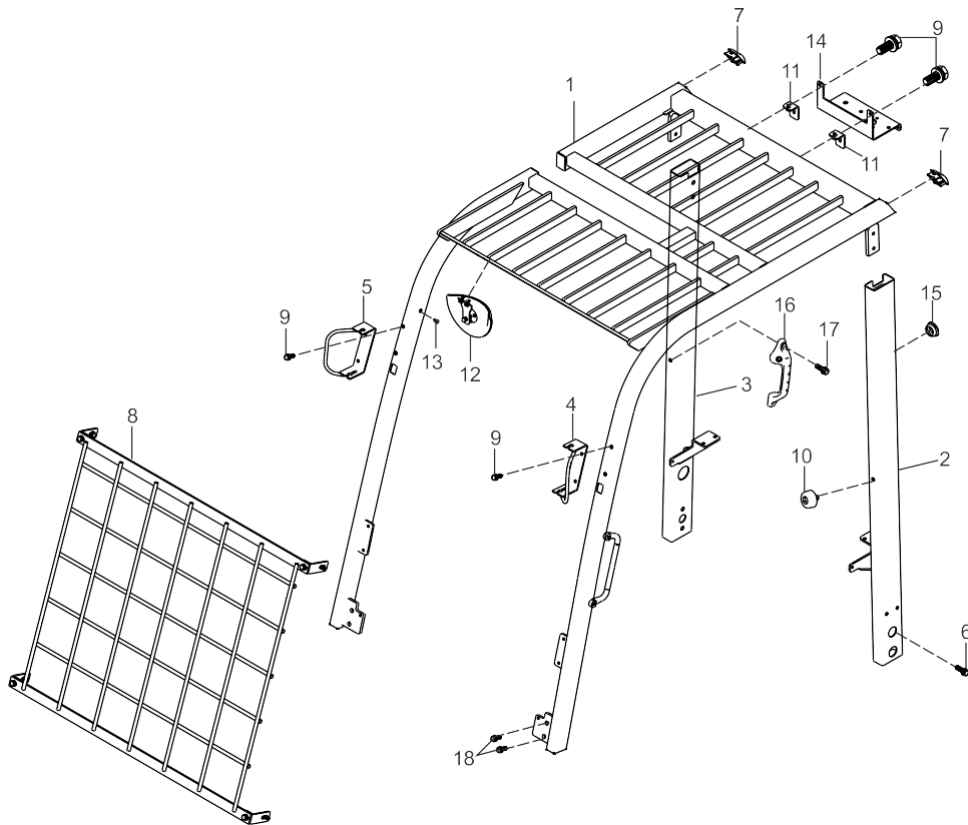

HRA1755101 01 Roof guard assembly

HRA1755101 01 护顶架总成

序号 No.	零部件代号 Part No.	版本 Edition	名称 Part name		数量 Q'ty	备注 Remark	
1	A1755-10201B	00	Top Frame Assembly	顶框架总成	1		
1	A1755-10201A	00	Top Frame Assembly	顶框架总成	1		
1	A1755-10201	00	Top Frame Assembly	顶框架总成	1		
1	A1755-10101JSS	01	Top Frame Assembly	顶框架总成	1	Standard bridge roof guard frame	标准驾驶室 护顶架
2	A1755-10301A	00	Rear leg assembly (left)	后腿总成(左)	1		
2	A1755-10301	00	Rear leg assembly (left)	后腿总成(左)	1		
3	A1755-10401A	00	Rear leg assembly (right)	后腿总成(右)	1		
3	A1755-10401	00	Rear leg assembly (right)	后腿总成(右)	1		
4	AF935-10271	01	Bracket L.H.	前大灯支架总成(左)	1		
5	AF935-10261	02	Bracket R.H.	前大灯支架总成(右)	1		
6	B0530-12040-X	00	Combined bolt M12x1.25x40	组合螺栓 M12x1.25x40	8	GB5786,GB 93,GB97.1	GB5786,GB 93,GB97.1
7	A63E5-12201	01	Cup	边管罩	2		
8	ABG75-10801	01	Mounting gp-guard	防护网安装总成	1	Optional protective net	选装防护网
9	B0330-08020-X	00	Combined bolt	组合螺栓 M8x20	6	GB/T 9074.17-88	GB/T 9074.17-88
10	23456-42181G	02	Rubber	缓冲胶垫	2		
11	A7BZ5-11021	00	Bracket	牌照支架总成	2		
12	H2MD5-11001	03	Backup,mirror	后视镜安装总成	1		
13	KM915-12171	00	Plug	堵头	2		
14	ABG75-12521A	02	Plate	警示灯板	1		
15	AP615-12241	00	Cap	装饰盖	2		
16	AE675-10311	01	Handle,grip	后把手总成	1		
17	B8030-08020	00	Screw	螺钉 M8x20	2	GB70-85	GB70-85
18	B0330-10030-X	00	Combined bolt	组合螺栓 M10x30	4	GB/T 9074.17-88	GB/T 9074.17-88

A7BZ5-11021 00 Bracket

A7BZ5-11021 00 牌照支架总成

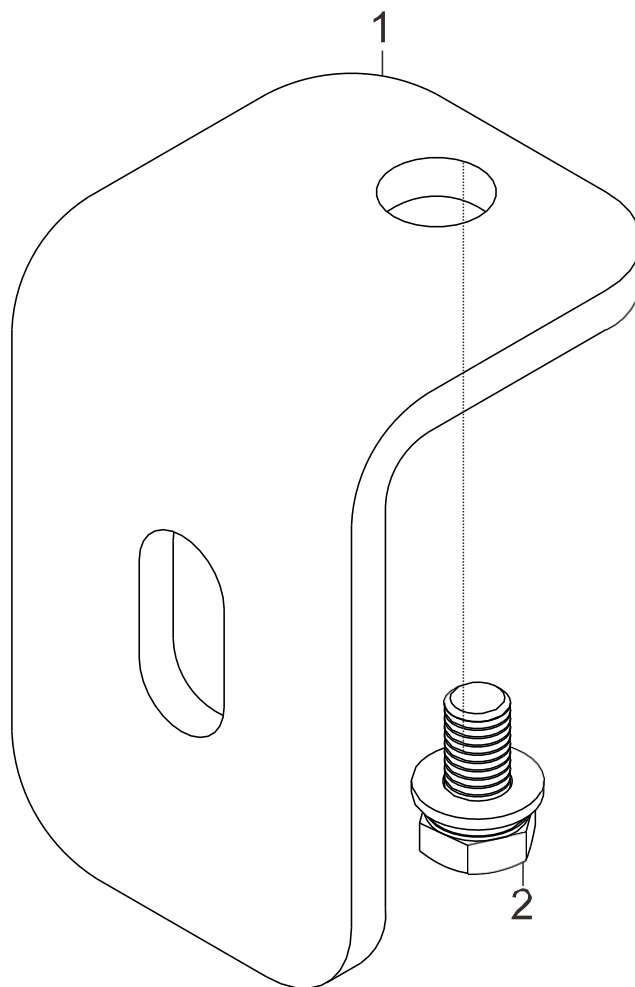

A7BZ5-11021 00 Bracket

A7BZ5-11021 00 牌照支架总成

序号 No.	零部件代号 Part No.	版本 Edition	名称 Part name		数量 Q'ty	备注 Remark	
1	A7BZ5-12521	02	Licence holder	牌照支架	1		
2	B0330-08016-X	00	Combined bolt	组合螺栓 M8x16	1	GB/T 9074.17-88	GB/T 9074.17-88

H2MD5-11001 03 Backup,mirror

H2MD5-11001 03 后视镜安装总成

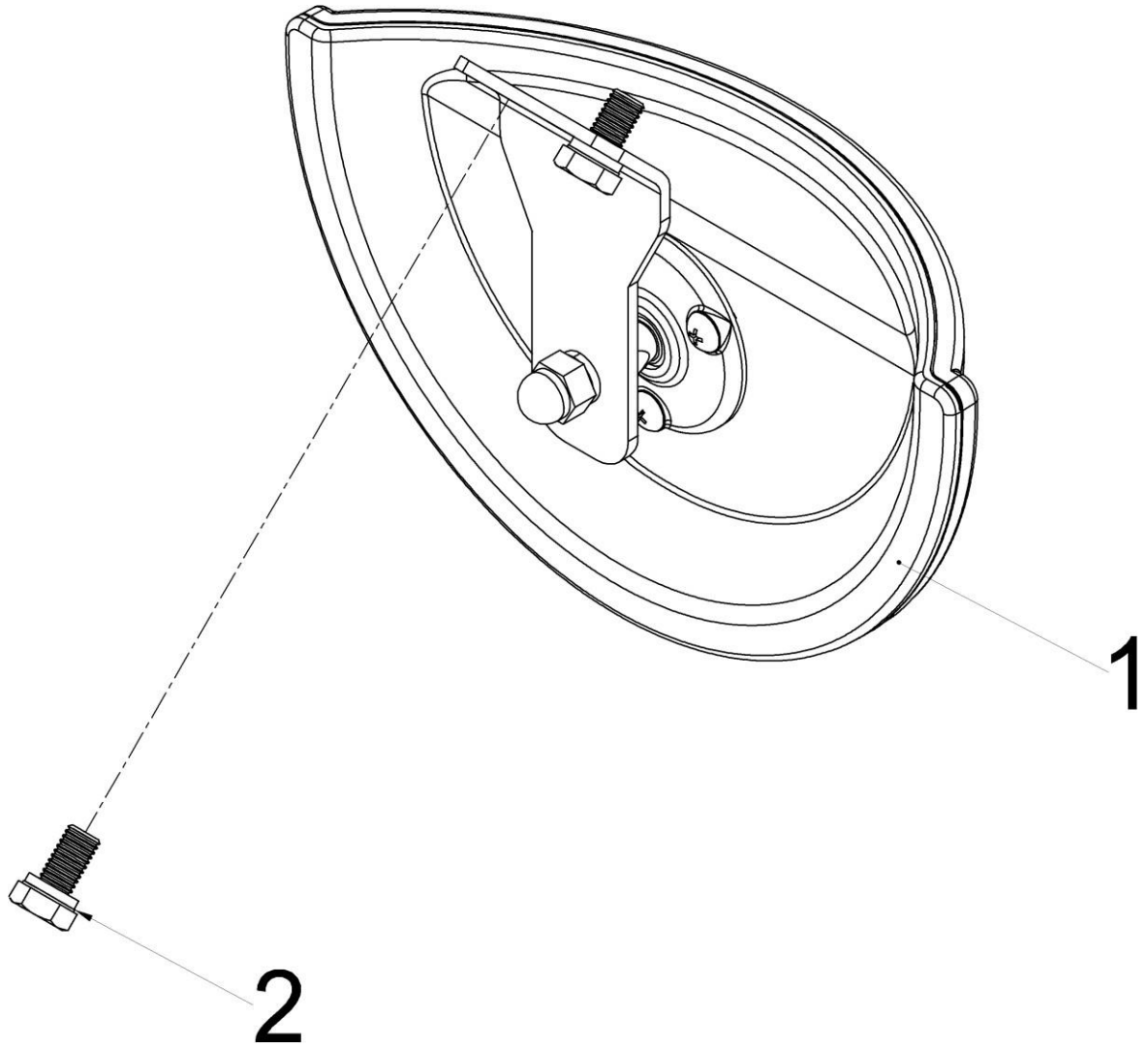

H2MD5-11001 03 Backup,mirror							
H2MD5-11001 03 后视镜安装总成							
序号 No.	零部件代号 Part No.	版本 Edition	名称 Part name		数量 Q'ty	备注 Remark	
1	H1M56-41511	01	Backup,mirror ass'y	广角后视镜总成	1		
2	B0330-08016-X1	00	Combined bolt	组合螺栓 M8x16	2	GB/T9074.1 5-88	GB/T9074.1 5-88

HRD2BP8001 02 Lifting system

HRD2BP8001 02 起重系统总成(M)

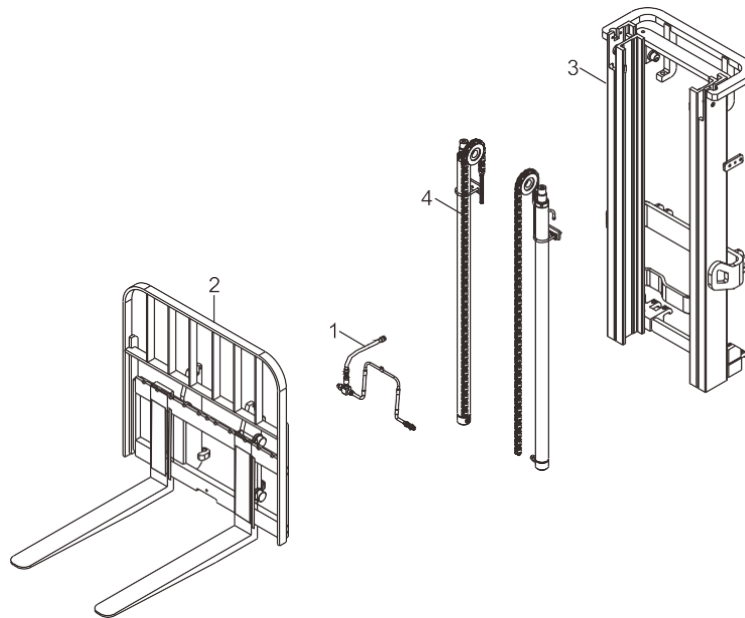

HRD2BP8001 02 Lifting system							
HRD2BP8001 02 起重系统总成(M)							
序号 No.	零部件代号 Part No.	版本 Edition	名称 Part name		数量 Q'ty	备注 Remark	
1	HRD9FL8601	11	Mast hydraulic system	门架管路系统(公制 24° 锥)	1		
1	HRD9FL8603	01	Mast hydraulic system(SAE)	门架管路系统(美制)	1		
2	HRD2BP8001-1	02	Lift bracket & backrest	货叉架及挡货架	1		
3	HRD2BP8001-2	02	Mast	门架	1		
4	HRD9DL8401	04	Rear lift cylinder mounting	后起升油缸安装图	1		

HRD9FL8601 11 Mast hydraulic system

HRD9FL8601 11 门架管路系统 (公制 24°锥)

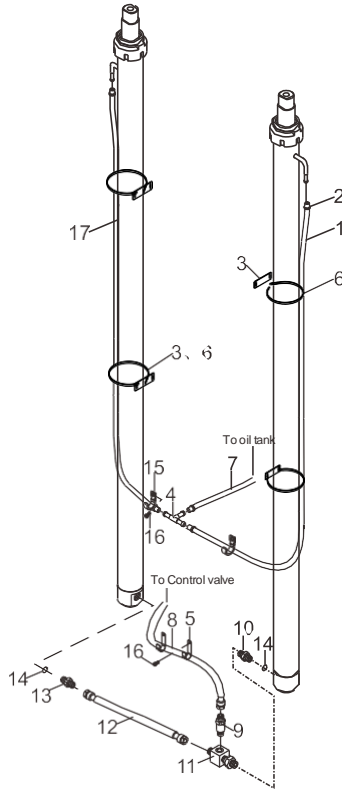

门架管路系统选用件 Selection of Portal Piping System				
起升高度 Lifting Height	序号01塑料回油管 Serial number 01, plastic tubing		序号17塑料回油管 Serial number 17, plastic tubing	
	2t, 3.5t, 3.8t	3t	2t, 3.5t, 3.8t	3t
M200	Z7400-12130	Z7400-12125	Z7400-12065	Z7400-12060
225	Z7400-12145	Z7400-12145	Z7400-12075	Z7400-12070
250	Z7400-12155	Z7400-12150	Z7400-12090	Z7400-12085
270	Z7400-12165	Z7400-12160	Z7400-12100	Z7400-12095
300	Z7400-12180	Z7400-12175	Z7400-12115	Z7400-12110
330	Z7400-12195	Z7400-12190	Z7400-12130	Z7400-12125
350	Z7400-12205	Z7400-12200	Z7400-12140	Z7400-12135
370	Z7400-12215	Z7400-12210	Z7400-12150	Z7400-12145
400	Z7400-12235	Z7400-12230	Z7400-12170	Z7400-12165
425	Z7400-12250	Z7400-12245	Z7400-12185	Z7400-12180
450	Z7400-12260	Z7400-12255	Z7400-12195	Z7400-12190
475	Z7400-12275	Z7400-12270	Z7400-12210	Z7400-12205
500	Z7400-12285	Z7400-12280	Z7400-12220	Z7400-12215
550	Z7400-12315	Z7400-12310	Z7400-12250	Z7400-12245
600	Z7400-12340	Z7400-12335	Z7400-12275	Z7400-12270

HRD9FL8601 11 Mast hydraulic system

HRD9FL8601 11 门架管路系统 (公制 24°锥)

序号 No.	零部件代号 Part No.	版本 Edition	名称 Part name		数量 Q'ty	备注 Remark	
1	Z7400-12000	00	Hose	塑料管	1	See table	见附表
2	Z4710-00014	00	Elastic hoop	钢带型弹性环箍Φ14	5		
3	54235-52701H	00	Band	回油管夹片	4		
4	JT6031-08001	00	Oil return joint	升降缸回油接头	1		
5	D9FL8-62041	03	Pipe clamp	管夹	2		
6	Z9260-80350	00	8 x350 strapping tape	捆扎带 8x350	4		
7	Z7400-12105	00	Plastic hose	塑料回油管Φ12x1050	1		
8	Z9702-1610024NL	00	Hose H.P.	高压胶管 16IIx1000	1		
9	D9FL8-60481	03	Flow regulator	限速阀	1	2-2.5T	2-2.5T
9	D9FL8-60901E	03	Flow regulator	限速阀	1	3T	3T
9	D9FL8-60901A	00	Flow regulator	限速阀	1	3.5T	3.5T
10	D9FL8-62031	01	Straight joint	直通接头	1		
11	D9FL8-62021	00	Three way	三通接头	1		
12	Z9702-1304122	00	Hose H.P.	高压胶管 13II x410	1	3-3.8T	3-3.8T
12	Z9702-1304022	00	Hose H.P.	高压胶管 13II x400	1	2-2.5T	2-2.5T
13	D9FL8-62011	01	Check valve	升降缸切断阀	1	2-3t	2-3t
13	D9FL8-62051	00	Check valve	切断阀	1	3.5,3.8t	3.5,3.8t
14	Z6006-01782	00	O-ring	O 型密封圈 17.8x2.4	2		
15	D2MD8-70001	00	Clip	管卡总成	2		
16	B0330-06012-X1	00	Combined bolt M6X12	组合螺栓 M6X12	4	GB5783,GB93	GB5783,GB93
17	Z7400-12000	00	Hose	塑料管	1	See table	见附表

HRD9FL8603 01 Mast hydraulic system(SAE)

HRD9FL8603 01 门架管路系统(美制)

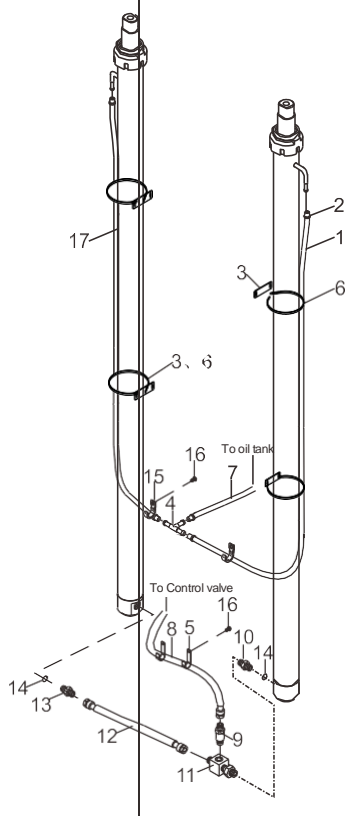

门架管路系统选用件
 MAST HYDRAULIC SYSTEM OPTION TABLE

起升高度 LIFTING HEIGHT	序号01塑料回油管 ITEM NO. 01 PLASTIC HOSE		序号17塑料回油管 ITEM NO. 17 PLASTIC HOSE	
	2, 3 5, 3 8t	3T	2, 3 5, 3 8t	3T
M200	Z7400-12130	Z7400-12125	Z7400-12065	Z7400-12060
225	Z7400-12145	Z7400-12140	Z7400-12075	Z7400-12070
250	Z7400-12155	Z7400-12150	Z7400-12090	Z7400-12085
270	Z7400-12165	Z7400-12160	Z7400-12100	Z7400-12095
300	Z7400-12180	Z7400-12175	Z7400-12115	Z7400-12110
330	Z7400-12195	Z7400-12190	Z7400-12130	Z7400-12125
350	Z7400-12205	Z7400-12200	Z7400-12140	Z7400-12135
370	Z7400-12215	Z7400-12210	Z7400-12150	Z7400-12145
400	Z7400-12235	Z7400-12230	Z7400-12170	Z7400-12165
425	Z7400-12250	Z7400-12245	Z7400-12185	Z7400-12180
450	Z7400-12260	Z7400-12255	Z7400-12195	Z7400-12190
475	Z7400-12275	Z7400-12270	Z7400-12210	Z7400-12205
500	Z7400-12285	Z7400-12280	Z7400-12220	Z7400-12215
550	Z7400-12315	Z7400-12310	Z7400-12250	Z7400-12245
600	Z7400-12340	Z7400-12335	Z7400-12275	Z7400-12270

HRD9FL8603 01 Mast hydraulic system(SAE)							
HRD9FL8603 01 门架管路系统(美制)							
序号 No.	零部件代号 Part No.	版本 Edition	名称 Part name		数量 Q'ty	备注 Remark	
1	Z7400-12000	00	Hose	塑料管	1	See table	见附表
2	Z4710-00014	00	Elastic hoop	钢带型弹性环箍Φ14	5		
3	54235-52701H	00	Band	回油管夹片	4		
4	JT6031-08001	00	Oil return joint	升降缸回油接头	1		
5	D9FL8-62041	03	Pipe clamp	管夹	2		
6	Z9260-80350	00	8 x350 strapping tape	捆扎带 8x350	4		
7	Z7400-12105	00	Plastic hose	塑料回油管Φ12x1050	1		
8	Z7802-16A10024NL	00	Hose H.P.	高压胶管	1		
9	D2N58-20101	00	Flow regulator	限速阀(美制)	1	2-2.5T	2-2.5T
9	D2N58-20131	00	Flow regulator	限速阀	1	3T	3T
9	D2N58-20151	00	Flow regulator	限速阀	1	3.5,3.8T	3.5,3.8T
10	D9FL8-62071	00	Straight joint	直通接头	1		
11	D2Q58-71031	00	Three way	三通接头(美制)	1		
12	Z7802-1304322	00	Hose H.P.	高压胶管	1	3-3.8T	3-3.8T
12	Z7802-1304022	00	Hose H.P.	高压胶管	1	2-2.5T	2-2.5T
13	E22A8-60211	01	Check valve	切断阀	1	2-3t, Include 14	2-3t,包含 14
13	D9FL8-62081	00	Check valve	切断阀	1	3.5,3.8t, Include 14	3.5,3.8t,包含 14
14	Z6006-01782	00	O-ring	O 型密封圈 17.8x2.4	2		
15	D2MD8-70001	00	Clip	管卡总成	2		
16	B0330-06012-X1	00	Combined bolt M6X12	组合螺栓 M6X12	4	GB5783,GB 93	GB5783,GB 93
17	Z7400-12000	00	Hose	塑料管	1	See table	见附表

HRD2BP8001-1 02 Lift bracket & backrest

HRD2BP8001-1 02 货叉架及挡货架

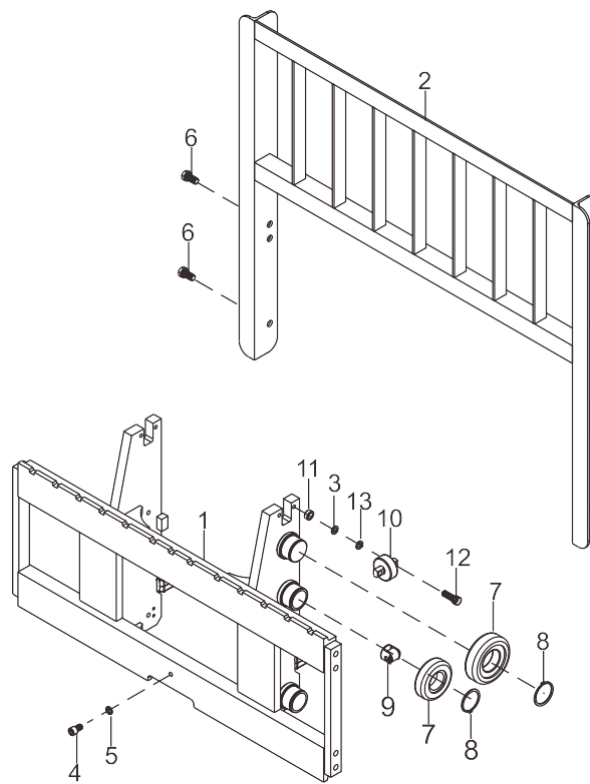

HRD2BP8001-1 02 Lift bracket & backrest

HRD2BP8001-1 02 货叉架及挡货架

序号 No.	零部件代号 Part No.	版本 Edition	名称 Part name		数量 Q'ty	备注 Remark	
1	HRD9DL8201	06	Lift bracket assembly	货叉架总成	1		
1	HRD9DL8201W	00	Lift bracket assembly	货叉架总成	1	Optional	选配
2	D7DH8-40001	00	2-2.5t Backrest	2-2.5t 挡货架	1		
2	HRD7DH8401W	00	Backrest with non-standard width	2-2.5 吨非标宽系列挡货架	1	Optional	选配
2	HRD7DH8402H	00	Backrest with non-standard height	2-2.5 吨非标高系列挡货架	1	Optional	选配
3	22548-34061	02	Shim	调整垫圈	1	AR	按需
4	B8030-12020	00	Screw M12x20	螺钉 M12x20	1	GB70-85	GB70-85
5	B5050-00012	00	Washer	垫圈 12	1	GB93-87	GB93-87
6	B0330-14025-X1	00	Combined bolt M14X25	组合螺栓 M14X25	4	GB5783,GB93	GB5783,GB93
7	980811N	03	Roller	滚轮	6		
8	B6150-00055	00	Snap ring	挡圈 55	6	GB894.1-86	GB894.1-86
9	DH2E8-70211	00	Recombination roller	复合滚轮	4		
10	D28R0-92031	01	Side roller	侧滚轮	2		
11	D28R0-92011	02	Spacer	调整垫块	4		
12	B0530-10045-X1	00	Combined bolt M10x1.25x45	组合螺栓 M10x1.25x45	4	GB5786,GB93	GB5786,GB93
13	22548-34051	02	Shim	调整垫圈	1	AR	按需

HRD2BP8001-2 02 Mast

HRD2BP8001-2 02 门架

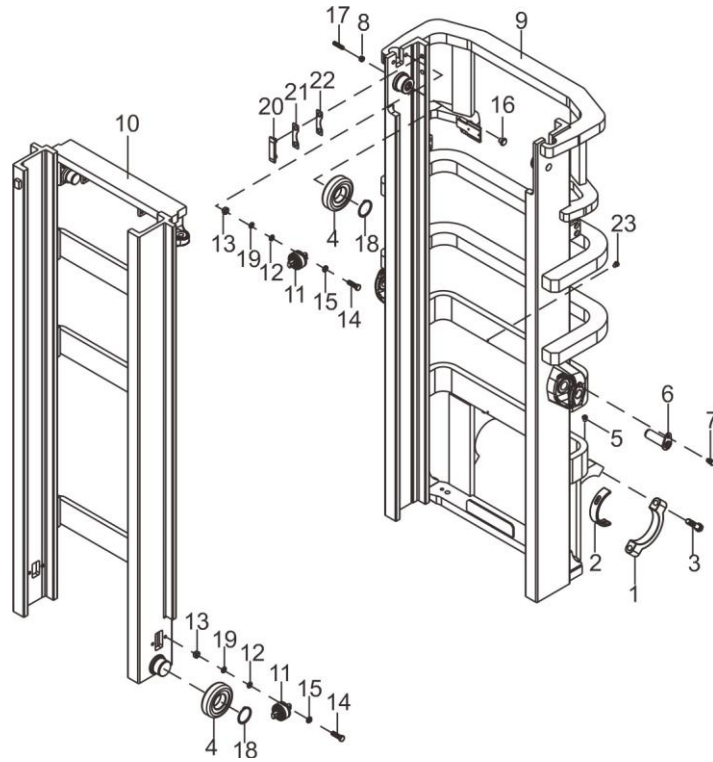

fl mi'IWt-*
MAST OPTIONAL PARTS

il< fl-φJl LIFTING HEIGHT	1'HIAA, φ,lix. OUTER MAST	F'HIAA, φ,lix. INNER MAST	im REARMK
M200	HRD2M08301 D2MOR-1nn11	HRD9DL8302 QOQLR-11n11	
225	HRD2M08301 D2MDR-10021	HR090L8302 D9DLR-11021	
250	HRD2M08301 D2MD8-30031	HR090L8302 D9DL8-31031	
270	HRD2M08301 D2MDR-1nnn1	HR090L8302 D0DLR-11n41	
300	HRD2M08301 D2MD8-30041	HR090L8302 D9DL8-31001	
330	HRD2M08301 D2MDA-1nncc1	HR090L8302 D9DLR-11ns1	
350	HRD2M08301 D2MD8-30061	HR090L8302 D9DL8-31061	
370	HR02MD8301 D2MD8-30071	HRD9DL8302 D9DL8-31071	
400	HRD2M08301 D2MD8-30081	HR090L8302 D9DL8-31081	
425	HRD2MD8301 D2MDR-1nna1	HRD9DL8302 D0DLR-11na1	
450	HRD2M08301 D2MD8-30111	HR090L8302 D9DL8-31101	
475	HRD2M08301 D2MDB-3*121	HR09DL8302 D9DL8-31111	
500	HRD2M08301 D2MDR-10111	HR090L8302 DQQLR-11121	
550	HRD2M08301 D2MD8-30141	HR090L8302 D9DL8-31131	
600	HRD2M08301 D2MDR-1n1s1	HR090L8302 D0DLR-11141	

HRD2BP8001-2 02 Mast

HRD2BP8001-2 02 门架

序号 No.	零部件代号 Part No.	版本 Edition	名称 Part name		数量 Q'ty	备注 Remark	
1	22018-30064	02	Mast support cover	门架支座盖	2		
2	D20B8-02001	03	Bushing	轴衬	2		
3	B0430-16070-X1	00	Combined bolt M16x1.5x70	组合螺栓 M16x1.5x70	4	GB5783,GB 93	GB5783,GB 93
4	980811N	03	Roller	滚轮	4		
5	Q700B01M	00	Fitting	直通式滑脂嘴	2	ZBT33001.1 -88	ZBT33001.1 -88
6	D2MD8-00161	03	Pin	倾斜缸销轴	2		
7	B0530-10020-X1	00	Combined bolt M10x1.25x20	组合螺栓 M10x1.25x20	2	GB5786-86	GB5786-86
8	B4123-00010	00	Nut	螺母 M10	2	GB6170-86	GB6170-86
9	HRD2BP8301	01	Outer mast	外门架总成	1	See table	见附表
10	HRD9DL8302	06	Inner mast	内门架总成	1	See table	见附表
11	23458-32051	02	Side roller	侧滚轮组 II	4		
12	22548-34051	02	Shim	调整垫圈	8		
13	23818-30071A	00	Spacer	垫块	8		
14	B0530-12040	00	Bolt M12x1.25x40	螺栓 M12x1.25x40	8	GB5786-86	GB5786-86
15	B5050-00012	00	Washer	垫圈 12	8	GB93-87	GB93-87
16	DD938-62001	00	Stop shift	限位轴	2		
17	DD938-62011	00	Screw	螺钉	2	GB79-85	GB79-85
18	B6150-00055	00	Snap ring	挡圈 55	2	GB894.1-86	GB894.1-86
19	22548-34061	02	Shim	调整垫圈	8		
20	D15X8-60501	02	Limit slider	限位滑块	2		
21	20029-43231*1	00	Shim	调整垫圈 δ 0.5	1	AR	按需
22	20029-43231*2	00	Shim	调整垫圈 δ 1.0	1	AR	按需
23	DGLN8-70108	00	Plug	内螺纹橡胶堵头	4		

HRD9DL8401 04 Rear lift cylinder mounting

HRD9DL8401 04 后起升油缸安装图

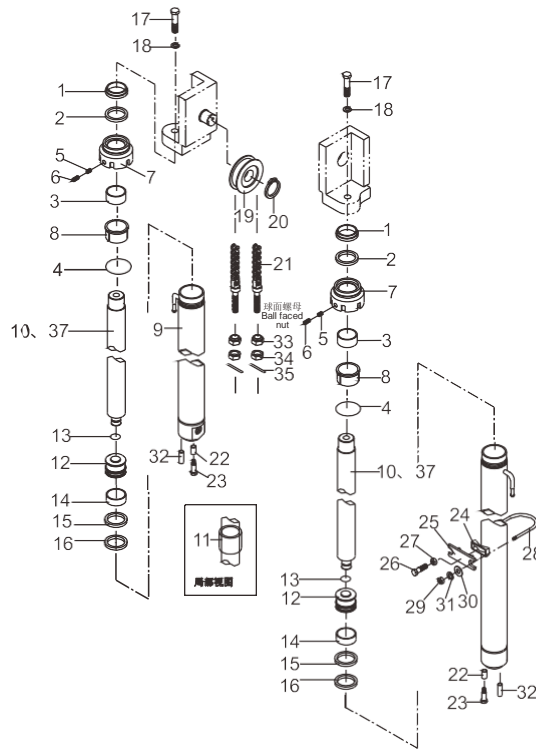

起升油缸安装选用件
LIFT CYLINDER MOUNTING OPTION TABLE

起升高度 LIFTING HEIGHT	起升油缸(左) LIFT CYLINDER (LEFT)	链条总成 CHAIN ASS'Y	调整套 SPACER	备注 REMARK
220	D2KD8-40311	HRLH1234021-71		
225	D2KD8-42251L	HRLH1234021-77		
250	D2KD8-40321	HRLH1234021-85		
270	D2KD8-40331	HRLH1234021-89		
300	D2KD8-40341	HRLH1234021-97		标准 std
330	D2KD8-40351	HRLH1234021-105		
350	D2KD8-40361	HRLH1234021-111		
370	D2KD8-40371	HRLH1234021-115		
400	D2KD8-40381	HRLH1234021-127	50	
425	D2KD8-40391	HRLH1234021-133	50	
450	D2KD8-40401	HRLH1234021-139	50	
475	D2KD8-40411	HRLH1234021-145	50	
500	D2KD8-40421	HRLH1234021-153	50	
550	D2KD8-40431	HRLH1234021-169	100	
600	D2KD8-40441	HRLH1234021-181	100	

HRD9DL8401 04 Rear lift cylinder mounting

HRD9DL8401 04 后起升油缸安装图

序号 No.	零部件代号 Part No.	版本 Edition	名称 Part name		数量 Q'ty	备注 Remark	
1	23650-83581	00	Dust ring	防尘圈	2		
2	23918-52161	00	U-ring	U 型圈	2		
3	C0 0637	00	O-ring 49.7x2.7	O 型密封圈 49.7x2.7	2		
4	GCCQ050XS-01	00	Guide sleeve	导向套	2		
5	Z2113-04030	00	Bushing 4030	钢背轴承 4030	2		
6	D2KD8.1-00	00	Cylinder body	缸体	2		
7	D2KD8-01	00	Piston rod	活塞杆	2		
8	D20B8-42381	00	Snap ring	钢丝挡圈	2		
9	TZT-40	00	Spacer	调整套	2	See table	见附表
10	GCCQ050QR-03	00	Piston	活塞	2		
11	27970-53141	00	Wearing	孔用支撑环 50x45x20	2		
12	23650-83531	00	Catch 50x40x3	挡片 50x40x3	2		
13	23650-83521	00	U-shaped seal	U 型密封圈	2		
14	GCCQ055DL4-07	00	Sleeve	套	2		
15	GCCQ055DL4-08	00	Snap ring	钢丝挡圈	2		
16	B3140-10026	00	Pin D10x26	销 D10x26	2	GB119-86	GB119-86
17	B0530-16040-X1	00	Combined bolt M16x1.5x40	组合螺栓 M16x1.5x40	2	GB5786,GB 93-87	GB5786,GB 93-87
18	23917-42191-3	00	Washer	垫圈	1		
19	D2KD8-74011	01	Sheave	链轮	2		
20	B6150-00040	00	Snap ring	挡圈 40	2	GB894.1-86	GB894.1-86
21	HRLH1234021-N	02	Chain assembly	链条总成	2	See table,include 32-34	见附表,包含 32-34
22	D20B8-42031	01	Spacer	隔套	2		
23	B0530-12025	00	Bolt M12x1.25x25	螺栓 M12x1.25x25	2	GB5786-86	GB5786-86
24	B5050-00010	00	Washer	垫圈 10	4	GB93-87	GB93-87
25	B0230-10045	00	Bolt	螺栓 M10x45	4	GB5782-86	GB5782-86
26	DE778-42031	00	Cushion	减震块	2		
27	DE778-42041	00	Plate	垫板	2		
28	DE778-42051	00	Shim	调整垫片	2		
29	DE778-42061	00	Shim	调整垫片	2		
30	DE778-42021	00	Lock plate	卡板	2		
31	DE778-40211	00	Plate assembly	卡板总成	2		

HRD9DL8401 04 Rear lift cylinder mounting

HRD9DL8401 04 后起升油缸安装图

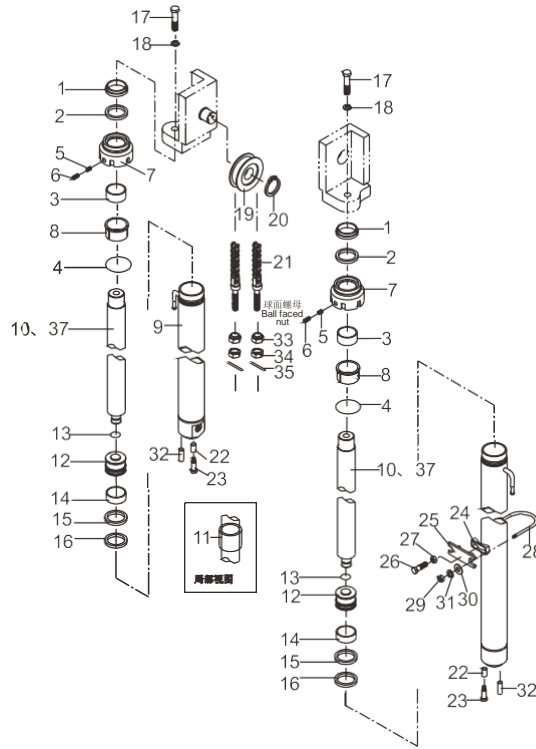

起升油缸安装选用件
LIFT CYLINDER MOUNTING OPTION TABLE

起升高度 LIFTING HEIGHT	起升油缸(左) LIFT CYLINDER (LEFT)	链条总成 CHAIN ASS'Y	调整套 SPACER	备注 REMARK
M200	D2KD8-40311	HRLH1234021-71		
225	D2KD8-42251L	HRLH1234021-77		
250	D2KD8-40321	HRLH1234021-85		
270	D2KD8-40331	HRLH1234021-89		
300	D2KD8-40341	HRLH1234021-97		标准 std
330	D2KD8-40351	HRLH1234021-105		
350	D2KD8-40361	HRLH1234021-111		
370	D2KD8-40371	HRLH1234021-115		
400	D2KD8-40381	HRLH1234021-127	50	
425	D2KD8-40391	HRLH1234021-133	50	
450	D2KD8-40401	HRLH1234021-139	50	
475	D2KD8-40411	HRLH1234021-145	50	
500	D2KD8-40421	HRLH1234021-153	50	
550	D2KD8-40431	HRLH1234021-169	100	
600	D2KD8-40441	HRLH1234021-181	100	

HRD9DL8401 04 Rear lift cylinder mounting

HRD9DL8401 04 后起升油缸安装图

序号 No.	零部件代号 Part No.	版本 Edition	名称 Part name		数量 Q'ty	备注 Remark	
32	B3010-3P230	00	Pin	开口销 3.2x30	4	GB91-86	GB91-86
33	B4230-00018	00	Nut M18x1.5	螺母 M18x1.5	4	GB6171-86	GB6171-86
34	22198-40192G	00	Ball faced nut M18x1.5	球面螺母 M18x1.5	4		
35	23917-42191-1	00	Washer	垫圈	3		
36	B5310-00010	00	Washer	垫圈 10	4	GB97.1-85	GB97.1-85
37	HRD2KD8402	03	Lift cylinder	左右起升油缸	2	See table,include 1-16	见附表,包含 1-16
38	HRD2KD8402XLB	00	Lift cylinder repair kits	起升油缸修理包	1		

HRDH2G8001 02 Lifting system (ZM),2-2.5t

HRDH2G8001 02 2-2.5t 起重系统(ZM)

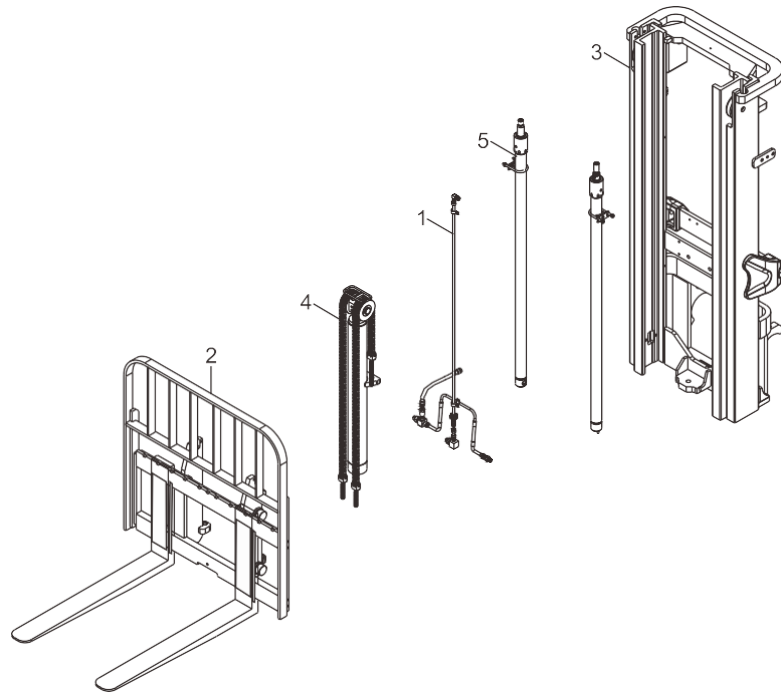

HRDH2G8001 02 Lifting system (ZM),2-2.5t

HRDH2G8001 02 2-2.5t 起重系统(ZM)

序号 No.	零部件代号 Part No.	版本 Edition	名称 Part name		数量 Q'ty	备注 Remark
1	HRDK3H8601	07	Mast hydraulic system	门架管路系统(24° 锥)	1	
1	HRDK3H8602	03	Mast hydraulic system(SAE)	门架管路系统(美制)	1	
2	HRDH2G8001-1	02	Lift bracket & backrest	货叉架及挡货架	1	
3	HRDH2G8001-2	02	Mast	门架	1	
4	HRDK2H8401-1	05	Front lift cylinder mounting	前起升油缸安装图	1	
5	HRDK2H8401-2	05	Rear lift cylinder mounting	后起升油缸安装图	1	

HRDK3H8601 07 Mast hydraulic system

HRDK3H8601 07 门架管路系统(24°锥)

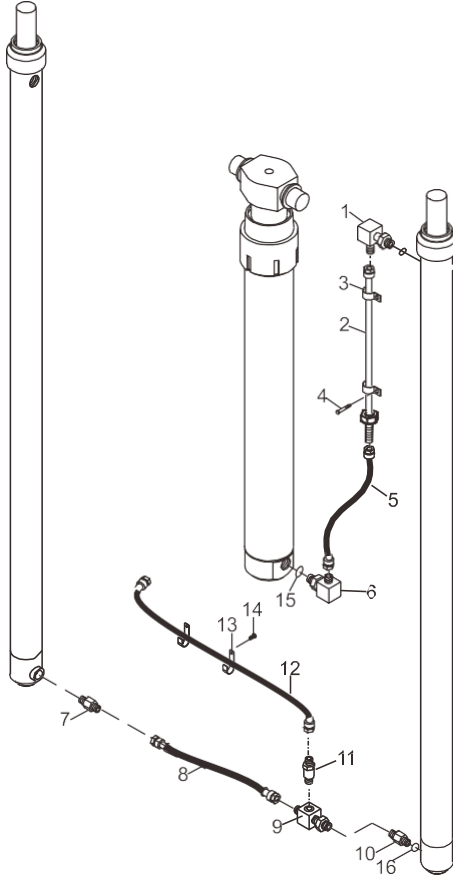

门架管路系统选用件
 MAST HYDRAULIC SYSTEM OPTION TABLE

起升高度	序号 钢管总成	备注

HRDK3H8601 07 Mast hydraulic system

HRDK3H8601 07 门架管路系统(24°锥)

序号 No.	零部件代号 Part No.	版本 Edition	名称 Part name		数量 Q'ty	备注 Remark	
1	JT6021-26011LOR	00	Straight joint	直通接头	1		
2	HRDK3H8611	00	Steel pipe	钢管总成	1	See table	见附表
3	DA2G8-60101	01	Lock plate	卡板	1		
4	B0330-08020-X	00	Combined bolt	组合螺栓 M8x20	1	GB/T9074.1 7-88	GB/T9074.1 7-88
5	Z9702- 1604524X10	00	Hose H.P.	高压胶管	1	Lifting height ≥ 3000	起升高度≥ 3000 时用
5	Z9702- 1604024X10	00	Hose H.P.	高压胶管	1	3000> Lifting height ≥2000	3000>起升 高度≥2000 时用
6	DG9N8-32351	01	Straight joint	直通接头	1	Include 15	包含 15
7	D9FL8-62011	01	Check valve	升降缸切断阀	1		
8	Z9702-1304122	00	Hose H.P.	高压胶管 13 II x410	1	3-3.8t	3-3.8t
8	Z9702-1303622	00	Hose	高压胶管 13 II x360	1	2-2.5t	2-2.5t
9	D9FL8-62021	00	Three way	三通接头	1		
10	D9FL8-62031	01	Straight joint	直通接头	1	3-3.8t, Include 16	3-3.8t,包含 16
10	D9FL8-62091	00	Straight joint	直通接头	1	2-2.5t	2-2.5t
11	D9FL8-60901E	03	Flow regulator	限速阀	1	3-3.5t	3-3.5t
11	D9FL8-60481	03	Flow regulator	限速阀	1	2-2.5t	2-2.5t
12	Z9702-1609524NL	00	Hose H.P.	高压胶管 16 II ×950	1		
13	D9FL8-62041	03	Pipe clamp	管夹	2		
14	B0330-06012-X1	00	Combined bolt M6X12	组合螺栓 M6X12	2	GB/T9074.1 7-88	GB/T9074.1 7-88
15	Z6006-02373	00	O-ring	O 型密封圈 23.7x3.5	1	JIS B2401	JIS B2401
16	Z6006-01782	00	O-ring	O 型密封圈 17.8x2.4	1	JIS B2401	JIS B2401

HRDK3H8602 00 Mast hydraulic system(SAE)

HRDK3H8602 00 门架管路系统(美制)

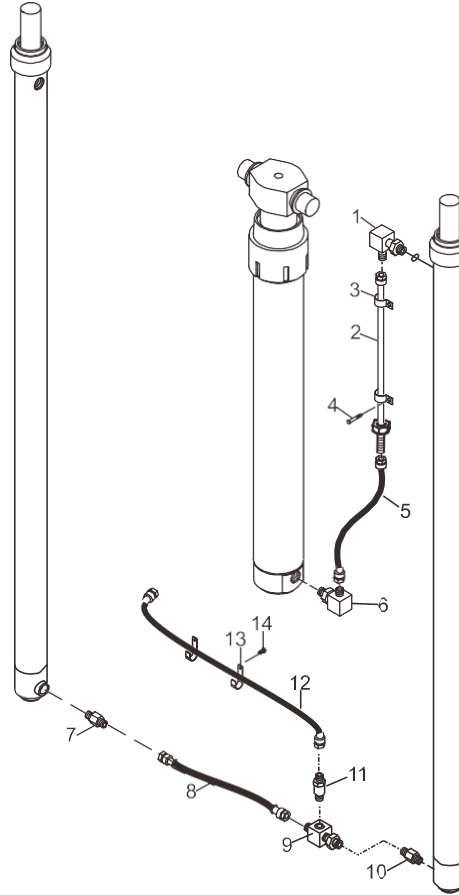

门架管路系统选用件
MAST HYDRAULIC SYSTEM OPTION TABLE

起升高度	序号 钢管总成	备注

HRDH2G8001-1 02 Lift bracket & backrest

HRDH2G8001-1 02 货叉架及挡货架

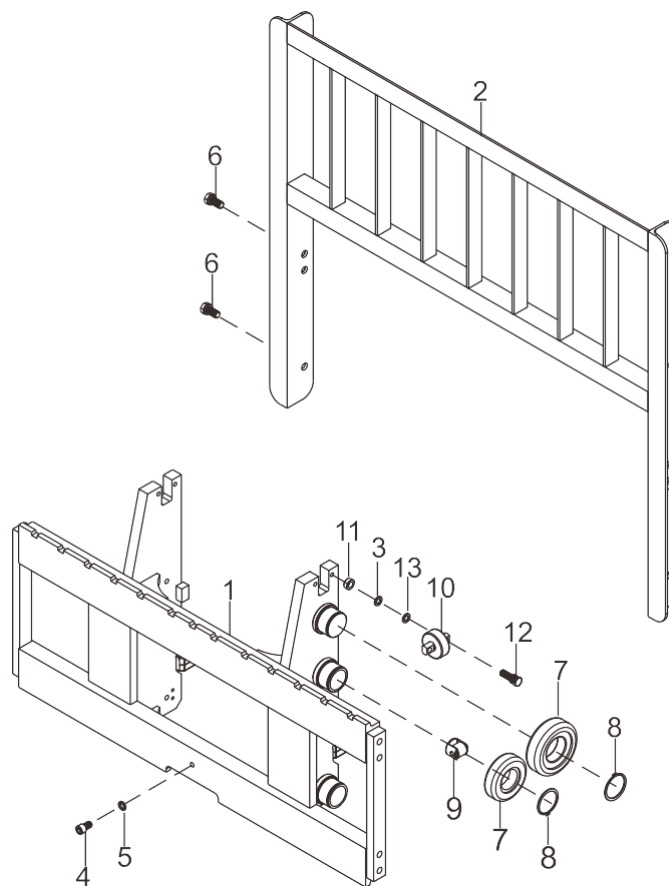

HRDH2G8001-1 02 Lift bracket & backrest							
HRDH2G8001-1 02 货叉架及挡货架							
序号 No.	零部件代号 Part No.	版本 Edition	名称 Part name		数量 Q'ty	备注 Remark	
1	HRDK2H8201	04	Lift bracket assembly	货叉架总成	1		
1	HRDK2H8201W	00	Widened series Lift bracket	加宽系列货叉架	1	Option	选用
2	D7DH8-40001	00	2-2.5t Backrest	2-2.5t 挡货架	1		
2	HRD7DH8401W	00	Backrest with non-standard width	2-2.5 吨非标宽系列挡货架	1	Option	选用
2	HRD7DH8402H	00	Backrest with non-standard height	2-2.5 吨非标高系列挡货架	1	Option	选用
3	22548-34061	02	Shim	调整垫圈	1	AR	按需
4	B8030-12020	00	Screw M12x20	螺钉 M12x20	1	GB70-85	GB70-85
5	B5050-00012	00	Washer	垫圈 12	1	GB93-87	GB93-87
6	B0330-14025-X1	00	Combined bolt M14X25	组合螺栓 M14X25	6	GB5783,GB93	GB5783,GB93
7	980811N	03	Roller	滚轮	6		
8	B6150-00055	00	Snap ring	挡圈 55	6	GB894.1-86	GB894.1-86
9	DH2E8-70211	00	Recombination roller	复合滚轮	4		
10	D28R0-92031	01	Side roller	侧滚轮	2		
11	D28R0-92011	02	Spacer	调整垫块	4		
12	B0530-10045-X1	00	Combined bolt M10x1.25x45	组合螺栓 M10x1.25x45	4	GB5786,GB93	GB5786,GB93
13	22548-34051	02	Shim	调整垫圈	1	AR	按需

HRDH2G8001-2 02 Mast

HRDH2G8001-2 02 门架

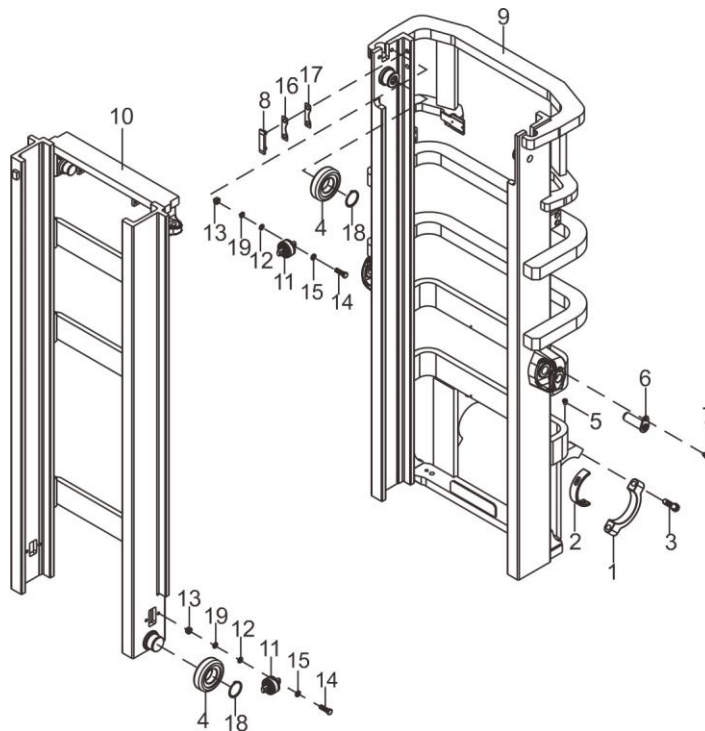

nomflit
MAST OPTION TABLE

lifting height	OUTER MAST	INNER MAST	REMARK
ZM200	HRDH2G8301 nH2r.s-1nn11	HRDK2H8302 OK2H8-10211	
225	HRDH2G8301 DHZGB-30021	HRDK2H8302 DK2HB-30221	
250	HRDH2G8301 DHZC.8-008 1	HRDK2H8302 DK2H8-10211	
270	HRDH2G8301 OHZC.8-10041	HRDK2H8302 DK2H8-10241	
300	HROH2G8301 OH2Gs-1nnn1	HROK2H8302 OK2HB-30201	tif.>1 std
330	HRDH2G8301 OH2C.8-008*1	HROK2H8302 OK2H8-1n2s1	
350	HROH2G8301 OHZGB-30061	HROK2H8302 OK2HB-30261	
370	HRDH2G8301 nH2r.s-1nn71	HROK2H8302 OK2H8-10271	
400	HROH2G8301 OHZGB-30081	HROK2H8302 OK2HB-30281	
425	HRDH2G8301 OH2r.s-1nn01	HROK2H8302 OK2H8-30291	
450	HROH2G8301 OHZGB-30101	HROK2H8302 OK2HB-30301	
475	HRDH2G8301 OHZC.8-10111	HRDK2H8302 OK2H8-10111	
500	HROH2G301 OHZGB-30121	HRDK2H8302 OK2HB-30321	
550	HRDH2G8301 OHZC.8-10111	HROK2H8302 OK2HR-0001	
600	HRDH2G8301 OH2G8-30141	HROK2H8302 DK2H8-30141	

HRDH2G8001-2 02 Mast							
HRDH2G8001-2 02 门架							
序号 No.	零部件代号 Part No.	版本 Edition	名称 Part name		数量 Q'ty	备注 Remark	
1	22018-30064	02	Mast support cover	门架支座盖	2		
2	D20B8-02001	03	Bushing	轴衬	2		
3	B0430-16070-X1	00	Combined bolt M16x1.5x70	组合螺栓 M16x1.5x70	4	GB5783,GB 93	GB5783,GB 93
4	980811N	03	Roller	滚轮	4		
5	Q700B01M	00	Fitting	直通式滑脂嘴	2	ZBT33001.2 -88	ZBT33001.2 -88
6	D2MD8-00161	03	Pin	倾斜缸销轴	2		
7	B0530-10020-X1	00	Combined bolt M10x1.25x20	组合螺栓 M10x1.25x20	2	GB5786-86	GB5786-86
8	D15X8-60501	02	Limit slider	限位滑块	2		
9	HRDH2G8301	01	Outer mast	外门架总成	1	See table	见附表
10	HRDK2H8302	02	Inner mast	内门架总成	1	See table	见附表
11	23458-32051	02	Side roller	侧滚轮组II	4		
12	22548-34051	02	Shim	调整垫圈	1	AR	按需
13	23818-30071A	00	Spacer	垫块	8		
14	B0530-12040	00	Bolt M12x1.25x40	螺栓 M12x1.25x40	8	GB5786-87	GB5786-87
15	B5050-00012	00	Washer	垫圈 12	8	GB93-87	GB93-87
16	20029-43231*1	00	Shim	调整垫圈 δ 0.5	1	AR	按需
17	20029-43231*2	00	Shim	调整垫圈 δ 1.0	1	AR	按需
18	B6150-00055	00	Snap ring	挡圈 55	4	GB894.1-86	GB894.1-86
19	22548-34061	02	Shim	调整垫圈	1	AR	按需
20	DGLN8-70108	00	Plug	内螺纹橡胶堵头	4		

HRDK2H8401-1 05 Front lift cylinder mounting

HRDK2H8401-1 05 前起升油缸安装图

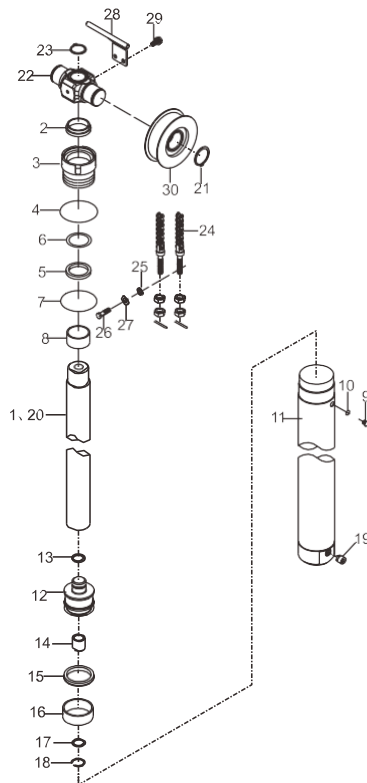

前起升油缸安装选用件
FRONT LIFT CYLINDER MOUNTING OPTION TABLE

起升高度	前起升油缸	链条总成	备注
			标准

HRDK2H8401-1 05 Front lift cylinder mounting

HRDK2H8401-1 05 前起升油缸安装图

序号 No.	零部件代号 Part No.	版本 Edition	名称 Part name		数量 Q'ty	备注 Remark	
1	HRDK2P8421	01	Front lift cylinder	前起升油缸	1	See table, include 2-20	见附表,包含 2-20
2	LBH-50	00	Dust ring DSI50x58x5/6.5	防尘圈 DSI50x58x5/6.5	1		
3	GCQ075HST3-02	00	Guide sleeve	导向套	1		
4	Z6003-08003	00	O-ring 80*3.1	O 形密封圈 80*3.1	1	GB1235-76	GB1235-76
5	24329-45591	00	Seal ring 50x60x6	轴用密封圈 50x60x6	1		
6	22658-52301	00	Catch	挡片 60x50x3	1		
7	Z6053-06903	00	O-ring 69*3.55	O 形密封圈 69*3.55	1		
8	Z2114-05040-Y	00	Bushing 5040	钢背轴承 5040	1		
9	B8032-05005	00	Screw	螺钉 M5x5	1	GB/T70-1985	GB/T70-1985
10	Q70B0-82141	01	Washer	垫片	1		
11	DK2P8421.1-00	00	Cylinder body	缸体	1		
12	D24P8-42001A	00	Piston assembly	活塞总成	1		
13	GCQ055DL4-04	00	Snap ring	钢丝挡圈	1		
14	D0W00.2-00	00	Valve assembly	阀总成	1		
15	PT03A0750-T64N	00	T-ring	T 型组合密封圈 75x61x6.3	1		
16	GCQ075JMD-05	00	Wearing 75x69x20	支承环 75x69x20	1		
17	GCQ075BX-05	00	Catch	挡片	1		
18	B6052-00022	00	Snap ring 22	挡圈 22	1		
19	QDFB2-90	00	Valve M27	安全阀 M27	1		
20	DK2P8421-01	00	Piston rod	活塞杆	1		
21	B6150-00040	00	Snap ring	挡圈 40	2	GB894.1-86	GB894.1-86
22	DK3P8-42191	01	Cylinder head sprocket seat	缸头链轮座	1		
23	B6150-00032	00	Snap ring 32	挡圈 32	1	GB894.1-86	GB894.1-86
24	HRLH1234021-N	02	Chain assembly	链条总成	2	See table	见附表
25	B5050-00014	00	Washer	垫圈 14	2	GB97.1-85	GB97.1-85
26	B0530-14050	00	Bolt M14x1.5x50	螺栓 M14x1.5x50	2	GB5786-86	GB5786-86
27	B5310-00014	00	Washer	垫圈 14	2	GB93-87	GB93-87
28	DK3P8-41031	00	Stopper, chain	护链板	1	Without hoses & pulley block	不装胶管滑轮组
29	B0330-08020-X	00	Combined bolt	组合螺栓 M8x20	2	GB5783, GB 93-87	GB5783, GB 93-87
30	DK3H8-42011	01	Sheave	链轮	2		

HRDK2H8401-2 05 Rear lift cylinder mounting

HRDK2H8401-2 05 后起升油缸安装图

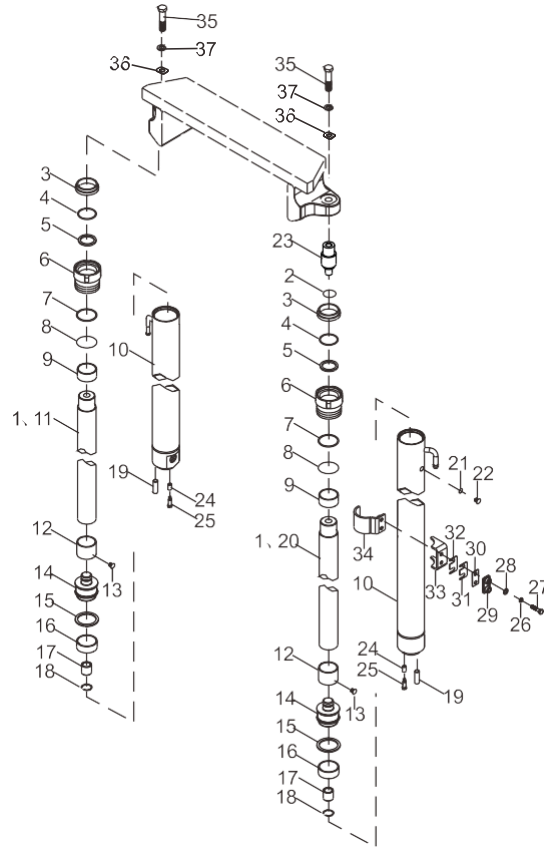

后起升油缸安装选用件
REAR LIFT CYLINDER MOUNTING OPTION TABLE

起升高度	后起升油缸左	后起升油缸右	调整套 度	备注
				标准

HRDK2H8401-2 05 Rear lift cylinder mounting

HRDK2H8401-2 05 后起升油缸安装图

序号 No.	零部件代号 Part No.	版本 Edition	名称 Part name		数量 Q'ty	备注 Remark	
1	HRDK2H8411	01	Rear lift cylinder	后起升油缸	2	See table, include 2-23	见附表, 包含 2-23
2	Z6053-02502	00	O-ring 25x2.65	O 形密封圈 25x2.65	1	GB3452.1-82	GB3452.1-82
3	27410-53111	00	Dust ring d35	防尘圈 d35	2		
4	23650-52861	00	Catch	挡片 φ 45x φ 35x3	2		
5	23650-52851	00	U-ring	U 型圈	2		
6	DK2H8411-02	00	Guide sleeve	导向套	2		
7	GCX050J2-06	00	Catch	挡圈 45x50x1.5	2		
8	Z6003-05003	00	O-ring	O 形密封圈 d50x3.1	2	GB3452.1-82	GB3452.1-82
9	Z2113-03530	00	Bushing	钢背轴承	2		
10	DK2H8411.1-00	00	Cylinder body	缸体	2		
11	DK2H8411-03R	00	Piston rod R.H.	右柱塞杆	1		
12	DK2H8411-04	00	Spacer	调整套	2	See table	见附表
13	B1832-04006	00	Screw	内六角锥端紧定螺钉 M4x6	4	GB/T78-2000	GB/T78-2000
14	DH2K8-42041	00	Piston	活塞	2		
15	PT0200450-T46	00	Ring	T 型特康格来圈 45x34x4.2	2		
16	GW0261P0	00	Wearing	支撑环 45x40x15	2		
17	DH2K8-42051	00	Sleeve	套	2		
18	D20B8-42381	00	Snap ring	钢丝挡圈	2		
19	B3130-10026	00	Pin	销 B10x26	2		
20	DK2H8411-03L	00	Piston rod L.H.	左柱塞杆	1		
21	Q7030-82141	00	Washer	垫片	2		
22	B8032-05005	00	Screw	螺钉 M5x5	2	GB/T70-1985	GB/T70-1985
23	DK2H8411-01	00	Joint	连接杆	1		
24	D20B8-42031	01	Spacer	隔套	2		
25	B0530-12025	00	Bolt M12x1.25x25	螺栓 M12x1.25x25	2	GB5786-86	GB5786-86
26	B5050-00010	00	Washer	垫圈 10	4	GB93-87	GB93-87
27	B0430-10045	00	Bolt	螺栓 M10x1.25x45	4	GB5785-86	GB5785-86
28	B5310-00010	00	Washer	垫圈 10	4	GB97.1-85	GB97.1-85
29	DE778-42031	00	Cushion	减震块	2		
30	DE778-42071	00	Plate	垫板	2	GB6171-86	GB6171-86
31	DE778-42051	00	Shim	调整垫片	4		

HRDH2N8001 02 2-2.5T Lifting system

HRDH2N8001 02 2-2.5T 起重系统(ZSM)

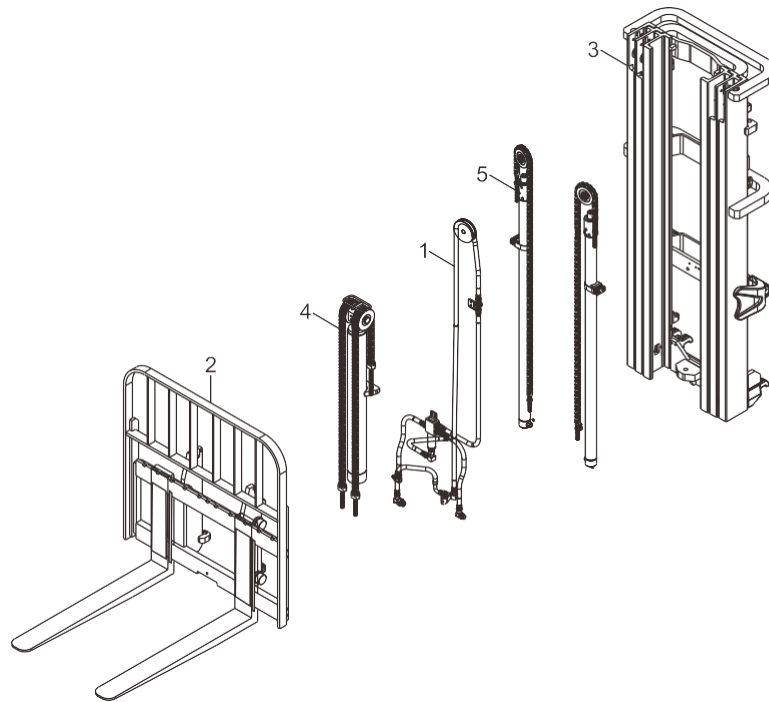

HRDK3P8601 10 Mast hydraulic system

HRDK3P8601 10 门架管路系统

序号 No.	零部件代号 Part No.	版本 Edition	名称 Part name		数量 Q'ty	备注 Remark	
1	B0330-08020-X	00	Combined bolt	组合螺栓 M8x20	9	GB/T9074.1 5-88	GB/T9074.1 5-88
2	DK3P8-61011	00	Pulley bracket	主滑轮支架	1		
3	DK3P8-62031	00	The main pulley	主滑轮	1		
4	B6150-00020	00	Snap ring	挡圈 20	1	GB894.1-86	GB894.1-86
5	DH2V8-62171	00	Washer	垫圈	1		
6	Z9702-1600024	00	Hose H.P.	高压胶管	1	See table	见附表
7	DK3P8-62011	02	Baffle joint support plate -JL	隔板接头支板-JL	1		
8	Z9702-1606024NL	00	Hose H.P.	高压胶管	1	3.2m	3.2m
8	Z9702-1606024	00	Hose H.P.	高压胶管	1	3.6,4m	3.6,4m
8	Z9702-1607024	00	Hose H.P.	高压胶管	1	≥4.35m	≥4.35m
9	DK3P8-61021	01	Three-way	三通接头总成	1		
10	JT6031- 26011LDJT	00	Three way joint	三通组合接头	1		
11	D9FL8-60481	03	Flow regulator	限速阀	1	2-2.5t	2-2.5t
11	D9FL8-60901E	03	Flow regulator	限速阀	1	3-3.8t	3-3.8t
11	DA378-60481	00	Flow regulator	限速阀	1	2-2.5t, electric H4 series	2-2.5t,电动 H4 系列
11	DA378-60651	00	Flow regulator	限速阀	1	3-3.8t, electric H4 series	3-3.8t,电动 H4 系列
12	Z6006-02373	00	O-ring	O 型密封圈 23.7x3.5	1	JIS B2401	JIS B2401
13	DK3P8-61041	01	Steel pipe assembly I	钢管总成 I	1		
14	DK3P8-61051	01	Steel pipe assembly II	钢管总成 II	1		
15	D9FL8-62011	01	Check valve	升降缸切断阀	1		
16	D9FL8-62031	01	Straight joint	直通接头	1	Include 30	包含 30
17	DK3P8-61061	01	Steel pipe assembly III	钢管总成 III	1		
18	DK3P8-62091	02	Steel pipe limit plate	钢管限位板	1		
19	DG9N8-32351	01	Straight joint	直通接头	1	Include 12	包含 12
20	Z4710-00014	00	Elastic hoop	钢带型弹性环箍 Φ14	5		
21	Z7400-12000	00	Hose	塑料管	1	See table	见附表
22	JT6031-08001	00	Oil return joint	升降缸回油接头	1		
23	54235-52701H	00	Band	回油管夹片	4		
24	Z9260-80350	00	8 x350 strapping tape	捆扎带 8x350	5		
25	Z9702-1606524NL	00	Hose H.P.	高压胶管, Φ161x650	1		

HRDK3P8602 01 Mast hydraulic system

HRDK3P8602 01 门架管路系统(美制)

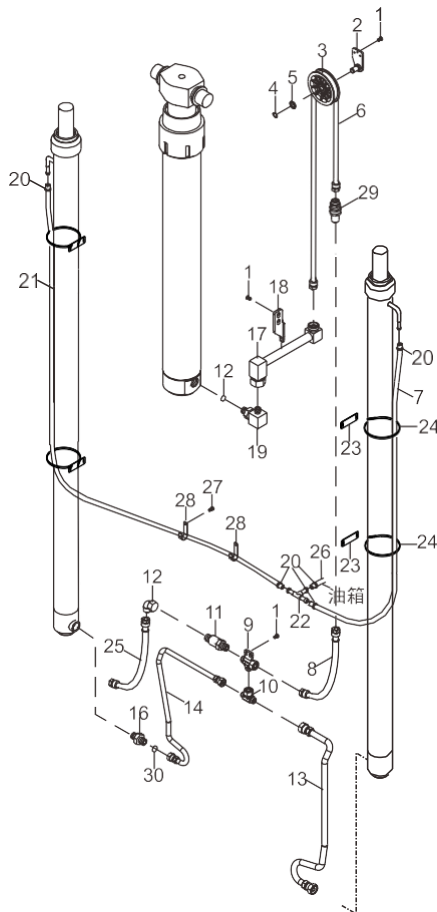

门架管路系统选用件 (2-2.5t) Selection of Portal Piping System(2-2.5t)			
起升高度 Lifting Height	序号06高压胶管 Serial number 06highpressure hose	序号21高压胶管 Serial number 21highpressure hose	序号07高压胶管 Serial number 07highpressure hose
ZSM360	1950	550	1100
400	2250	790	1250
435	2350	800	1350
450	2450	850	1400
470	2580	900	1450
480	2670	950	1500
500	2840	1050	1600
540	3020	1150	1700
600	3420	1350	1900
650	3800	1550	2100
700	4140	1700	2250
750	4470	1900	2450

门架管路系统选用件 (3-3.5t) Selection of Portal Piping System(3-3.5t)						
起升高度 Lifting Height	序号06 高压胶管 Serial number 06. high-		序号21 高压胶管 Serial number 21. high-		序号07高压胶管 Serial number 07. high-	
	3-3.5t	3.8t	3-3.5t	3.8t	3-3.5t	3.8t
ZSM360	2050	2170	600	650	1150	1200
400	2330	2450	750	800	1300	1350
435	2430	2550	850	900	1400	1450
450	2530	2650	900	950	1450	1500
470	2650	2770	950	1050	1500	1570
480	2730	2850	1000	1050	1550	1600
500	2920	3040	1100	1150	1650	1700
540	3100	3220	1200	1300	1750	1850
600	3500	3620	1400	1500	1950	2050
650	3880	4000	1600	1700	2150	2250
700	4220	4340	1750	1950	2300	2500
750	4850	4970	2100	2150	2650	2700
780	5050	5170	2200	2250	2750	2800

HRDK3P8602 01 Mast hydraulic system

HRDK3P8602 01 门架管路系统(美制)

序号 No.	零部件代号 Part No.	版本 Edition	名称 Part name		数量 Q'ty	备注 Remark	
1	B0330-08020-X	00	Combined bolt	组合螺栓 M8x20	9	GB/T9074.1 5-88	GB/T9074.1 5-88
2	DK3P8-61011	00	Pulley bracket	主滑轮支架	1		
3	DK3P8-62031	00	The main pulley	主滑轮	1		
4	B6150-00020	00	Snap ring	挡圈 20	1	GB894.1-86	GB894.1-86
5	DH2V8-62171	00	Washer	垫圈	1		
6	Z7802-16A00024	00	Hose H.P.	高压胶管	1	See table	见附表
7	Z7400-12000	00	Hose	塑料管	1	See table	见附表
8	Z7802-16A06024	00	Hose H.P.	高压胶管	1	3.6,4m	3.6,4m
8	Z7802-16A07024	00	Hose H.P.	高压胶管	1	≥4.35m	≥4.35m
9	DK3P8-60011	00	Three-way joint ass'y	三通接头总成I	1		
10	DK3P8-60021	00	Three-way joint ass'y	三通接头总成II	1		
11	D2N58-20101	00	Flow regulator	限速阀 (美制)	1	2-2.5t	2-2.5t
11	D2N58-20131	00	Flow regulator	限速阀	1	3-3.8t	3-3.8t
12	Z6006-02373	00	O-ring	O 型密封圈 23.7x3.5	1	JIS B2401	JIS B2401
13	DK3P8-60031	00	Steel pipe assembly I	钢管总成 I	1		
14	DK3P8-60041	00	Steel pipe assembly II	钢管总成 II	1		
15	E22A8-60211	01	Check valve	切断阀	1		
16	D9FL8-62071	00	Straight joint	直通接头	1	Include 30	包含 30
17	DK3P8-60091	00	Steel pipe assembly III	钢管总成 III	1		
18	DK3P8-62091	02	Steel pipe limit plate	钢管限位板	1		
19	D2Q58-70041	00	Three way	三通接头	1	Include 12	包含 12
20	Z4710-00014	00	Elastic hoop	钢带型弹性环箍 Φ14	5		
21	Z7400-12000	00	Hose	塑料管	1	See table	见附表
22	JT6031-08001	00	Oil return joint	升降缸回油接头	1		
23	54235-52701H	00	Band	回油管夹片	4		
24	Z9260-80350	00	8 x350 strapping tape	捆扎带 8x350	5		
25	Z7802- 16A06524NL	00	Hose H.P.	高压胶管	1		
26	Z7400-12110	00	Plastic hose	塑料回油管 Φ12x1100	1		
27	B0330-06012-X1	00	Combined bolt M6X12	组合螺栓 M6X12	2	GB/T9074.1 5-88	GB/T9074.1 5-88
28	D2MD8-70001	00	Clip	管卡总成	2		
29	DK3P8-60051	00	Straight joint	直通接头	1		

HRDK3P8602 01 Mast hydraulic system

HRDK3P8602 01 门架管路系统(美制)

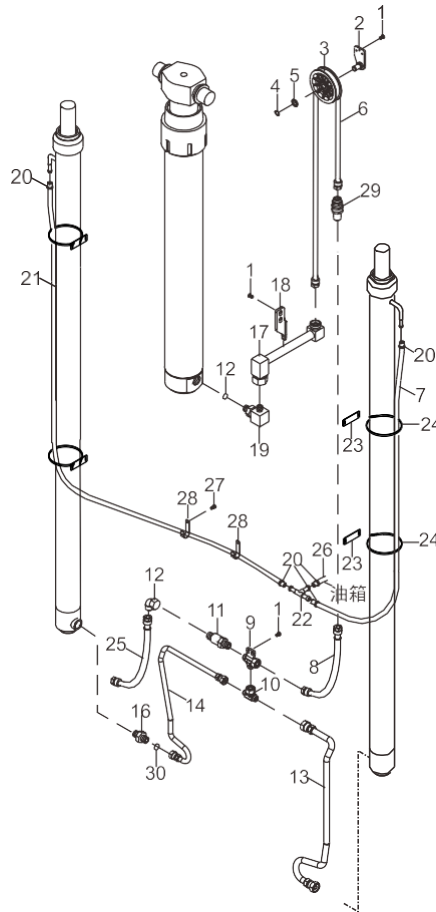

门架管路系统选用件 (2-2.5t) Selection of Portal Piping System(2-2.5t)			
起升高度 Lifting Height	序号06高压胶管 Serial number 06highpressure hose	序号21高压胶管 Serial number 21highpressure hose	序号07高压胶管 Serial number 07highpressure hose
ZSM360	1950	550	1100
400	2250	700	1250
435	2350	800	1350
450	2450	850	1400
470	2580	900	1450
480	2670	950	1500
500	2840	1050	1600
540	3020	1150	1700
600	3420	1350	1900
650	3800	1550	2100
700	4140	1700	2250
750	4470	1900	2450

门架管路系统选用件 (3-3.5t) Selection of Portal Piping System(3-3.5t)						
起升高度 Lifting Height	序号06 高压胶管 Serial number 06. high-		序号21 高压胶管 Serial number 21. high-		序号07高压胶管 Serial number 07. high-	
	3-3.5t	3.8t	3-3.5t	3.8t	3-3.5t	3.8t
ZSM360	2050	2170	600	650	1150	1200
400	2330	2450	750	800	1300	1350
435	2430	2550	850	900	1400	1450
450	2530	2650	900	950	1450	1500
470	2650	2770	950	1050	1500	1570
480	2730	2850	1000	1050	1550	1600
500	2920	3040	1100	1150	1650	1700
540	3100	3220	1200	1300	1750	1850
600	3500	3620	1400	1500	1950	2050
650	3880	4000	1600	1700	2150	2250
700	4220	4340	1750	1950	2300	2500
750	4850	4970	2100	2150	2650	2700
780	5050	5170	2200	2250	2750	2800

HRDK3P8602 01 Mast hydraulic system

HRDK3P8602 01 门架管路系统(美制)

序号 No.	零部件代号 Part No.	版本 Edition	名称 Part name		数量 Q'ty	备注 Remark	
30	Z6006-01782	00	O-ring	O 型密封圈 17.8x2.4	1	JIS B2401	JIS B2401

HRDH2N8001-1 02 Lift bracket & backrest

HRDH2N8001-1 02 货叉架及挡货架

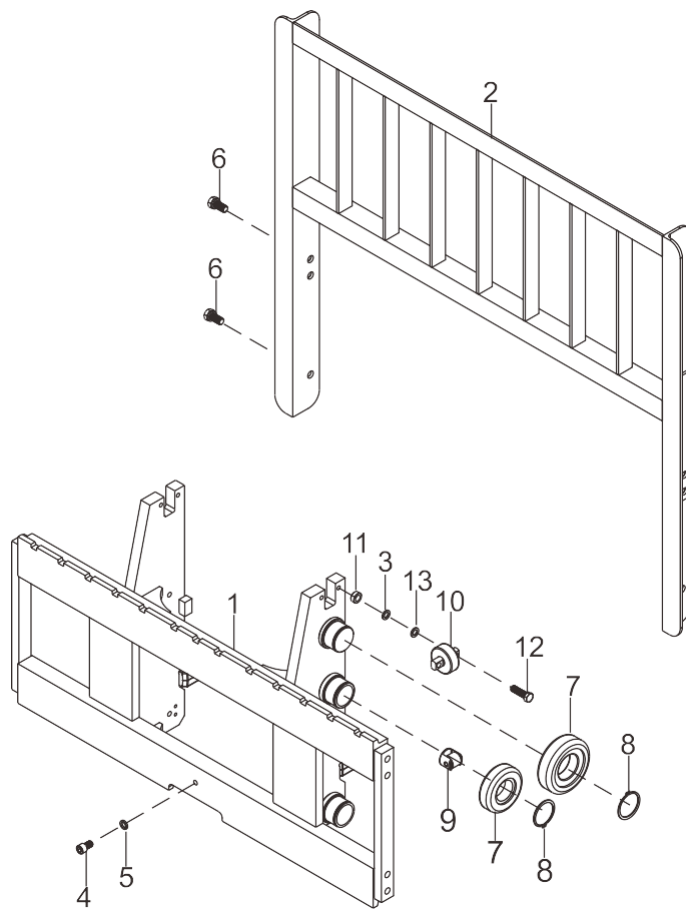

HRDH2N8001-1 02 Lift bracket & backrest

HRDH2N8001-1 02 货叉架及挡货架

序号 No.	零部件代号 Part No.	版本 Edition	名称 Part name		数量 Q'ty	备注 Remark	
1	HRDK2P8201	06	Lift bracket assembly	货叉架总成	1		
1	HRDK2P8201W	00	Widened series Lift bracket	加宽系列货叉架	1	Option	选用
2	D7DH8-40001	00	2-2.5t Backrest	2-2.5t 挡货架	1		
2	HRD7DH8401W	00	Backrest with non-standard width	2-2.5 吨非标宽系列挡货架	1	Option	选用
2	HRD7DH8402H	00	Backrest with non-standard height	2-2.5 吨非标高系列挡货架	1	Option	选用
3	22548-34061	02	Shim	调整垫圈	1	AR	按需
4	B8030-12020	00	Screw M12x20	螺钉 M12x20	1	GB70-85	GB70-85
5	B5050-00012	00	Washer	垫圈 12	1	GB93-87	GB93-87
6	B0330-14025-X1	00	Combined bolt M14X25	组合螺栓 M14X25	6	GB5783,GB 93	GB5783,GB 93
7	980811N	03	Roller	滚轮	6		
8	B6150-00055	00	Snap ring	挡圈 55	6	GB894.1-86	GB894.1-86
9	DH2E8-70211	00	Recombination roller	复合滚轮	4		
10	D28R0-92031	01	Side roller	侧滚轮	2		
11	D28R0-92011	02	Spacer	调整垫块	4		
12	B0530-10040-X1	00	Combined bolt M10x1.25x40	组合螺栓 M10x1.25x40	4	GB5783,GB 93	GB5783,GB 93
13	22548-34051	02	Shim	调整垫圈	1	AR	按需

HRDH2N8001-2 02 Mast

HRDH2N8001-2 02 门架

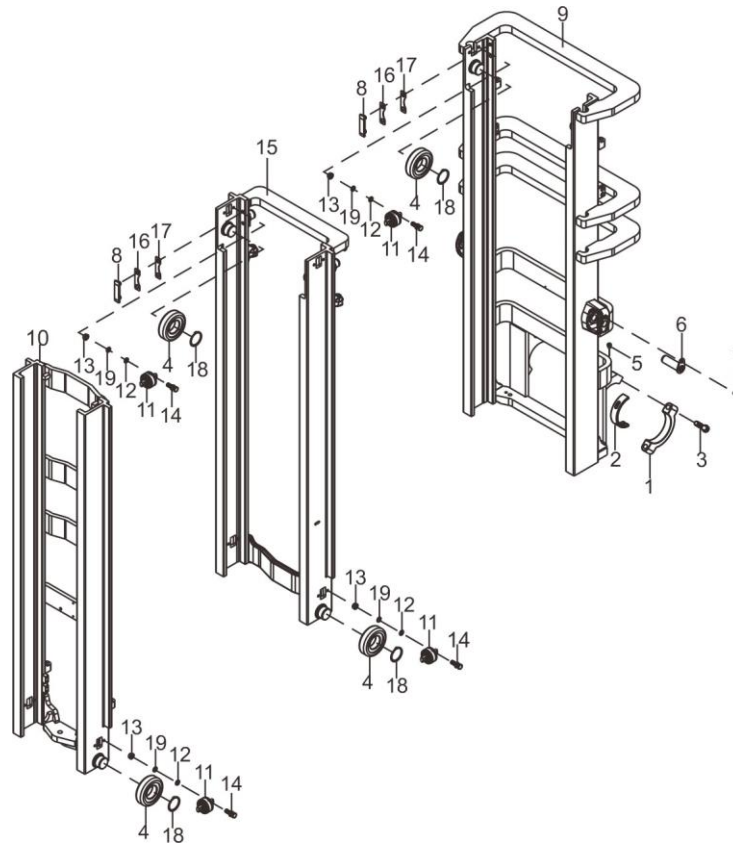

fl mmi*				
MAST OPTION TABLE				
ilft-r-N LIFTING HEICHT	leflAA φ-nl< OIJTER MAST	lflAA φ-nl< MIDDLE MAST	inAA φ-nl< INNER MAST	is-1 REMARK
ZSM360	DH2N8-30011	DK2P8-30211	DK2P8-30411	
40D	DH2N8-30021	DK2P8-30221	DK2P8-30421	
435	DH2N8-30001	DK2P8-30201	DK2P8-30401	f.f.;1, std
45D	DH2N8-30031	DK2P8-30231	DK2P8-30431	
470	DH2N8-30041	DK2P8-30241	DK2P8-30441	
480	DH2N8-30051	DK2P8-30251	DK2P8-30451	
500	DH2N8-30061	DK2P8-30261	DK2P8-30461	
54D	DH2N8-30071	DK2P8-30271	DK2P8-30471	
600	DH2N8-30081	DK2P8-30281	DK2P8-30481	
65D	DH2N8-30091	DK2P8-30291	DK2P8-30491	
700	DH2N8-30101	DK2P8-30301	DK2P8-30501	
750	DH2N8-30111	DK2P8-30311	DK2P8-30511	

HRDH2N8001-2 02 Mast

HRDH2N8001-2 02 门架

序号 No.	零部件代号 Part No.	版本 Edition	名称 Part name		数量 Q'ty	备注 Remark	
1	22018-30064	02	Mast support cover	门架支座盖	2		
2	D20B8-02001	03	Bushing	轴衬	2		
3	B0430-16070-X1	00	Combined bolt M16x1.5x70	组合螺栓 M16x1.5x70	4	GB5783,GB 93	GB5783,GB 93
4	980811N	03	Roller	滚轮	8		
5	Q700B01	00	Fitting	直通式滑脂嘴	2	ZBT33001.2 -88	ZBT33001.2 -88
6	D2MD8-00161	03	Pin	倾斜缸销轴	2		
7	B0530-10020-X1	00	Combined bolt M10x1.25x20	组合螺栓 M10x1.25x20	2	GB5786-86	GB5786-86
8	D15X8-60501	02	Limit slider	限位滑块	4		
9	HRDH2N8301	02	Outer mast	外门架总成	1	See table	见附表
10	HRDK2P8303	03	Inner mast	内门架总成	1	See table	见附表
11	23458-32051	02	Side roller	侧滚轮组 II	8		
12	22548-34051	02	Shim	调整垫圈	1	AR	按需
13	23818-30071A	00	Spacer	垫块	16		
14	B0530-12040-X1	00	Combined bolt M12x1.25x40	组合螺栓 M12x1.25x40	16	GB5786-87	GB5786-87
15	HRDK2P8302	05	Middle mast	中门架总成	1	See table	见附表
16	20029-43231*1	00	Shim	调整垫圈 δ 0.5	1	AR	按需
17	20029-43231*2	00	Shim	调整垫圈 δ 1.0	1	AR	按需
18	B6150-00055	00	Snap ring	挡圈 55	8	GB894.1-86	GB894.1-86
19	22548-34061	02	Shim	调整垫圈	1	AR	按需

HRDK2P8401-1 05 Front lift cylinder mounting

HRDK2P8401-1 05 前起升油缸安装图

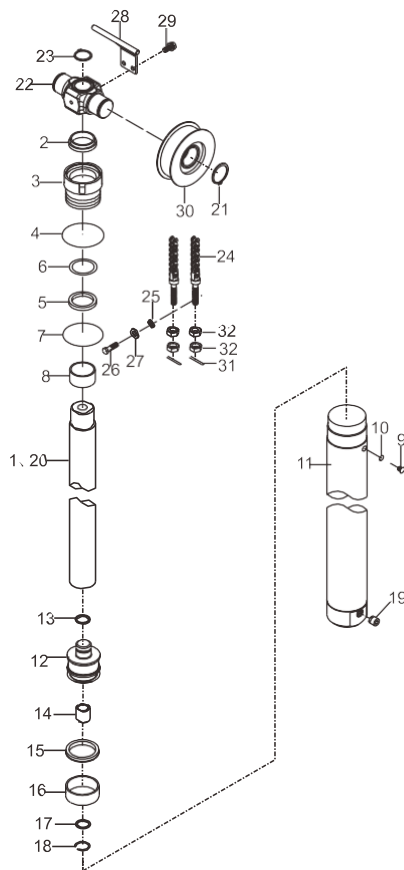

起升油缸安装选用件 LIFT CYLINDER MOUNTING OPTION TABLE			
起升高度 LIFTING HEIGHT	起升油缸安装 LIFT CYLINDER	链条总成 CHAIN ASS'Y	备注 REMARK
360	DK2P8-40441	HRLH1234021-75	
400	DK2P8-40461	HRLH1234021-83	
435	DK2P8-40401	HRLH1234021-85	标准std
450	DK2P8-40481	HRLH1234021-87	
470	DK2P8-40491	HRLH1234021-91	
480	DK2P8-40541	HRLH1234021-93	
500	DK2P8-40521	HRLH1234021-97	
540	DK2P8-40541	HRLH1234021-103	
600	DK2P8-40561	HRLH1234021-113	
650	DK2P8-40581	HRLH1234021-125	
700	DK2P8-40601	HRLH1234021-133	
750	DK2P8-40621	HRLH1234021-143	

HRDK2P8401-1 05 Front lift cylinder mounting

HRDK2P8401-1 05 前起升油缸安装图

序号 No.	零部件代号 Part No.	版本 Edition	名称 Part name		数量 Q'ty	备注 Remark	
1	HRDK2P8421	01	Front lift cylinder	前起升油缸	1	See table,include 2-20	见附表,包含 2-20
2	LBH-50	00	Dust ring DSI50x58x5/6.5	防尘圈 DSI50x58x5/6.5	1		
3	GCQ075HST3-02	00	Guide sleeve	导向套	1		
4	Z6003-08003	00	O-ring 80*3.1	O 形密封圈 80*3.1	1	GB1235-76	GB1235-76
5	24329-45591	00	Seal ring 50x60x6	轴用密封圈 50x60x6	1		
6	22658-52301	00	Catch	挡片 60x50x3	1		
7	Z6053-06903	00	O-ring 69*3.55	O 形密封圈 69*3.55	1		
8	Z2114-05040-Y	00	Bushing 5040	钢背轴承 5040	1		
9	B8032-05005	00	Screw	螺钉 M5x5	1	GB/T70-1985	GB/T70-1985
10	Q70B0-82141	01	Washer	垫片	1		
11	DK2P8421.1-00	00	Cylinder body	缸体	1		
12	D24P8-42001A	00	Piston assembly	活塞总成	1		
13	GCQ055DL4-04	00	Snap ring	钢丝挡圈	1		
14	D0W00.2-00	00	Valve assembly	阀总成	1		
15	PT03A0750-T64N	00	T-ring	T 型组合密封圈 75x61x6.3	1		
16	GCQ075JMD-05	00	Wearing 75x69x20	支承环 75x69x20	1		
17	GCQ075BX-05	00	Catch	挡片	1		
18	B6052-00022	00	Snap ring 22	挡圈 22	1		
19	QDFB2-90	00	Valve M27	安全阀 M27	1		
20	DK2P8421-01	00	Piston rod	活塞杆	1		
21	B6150-00040	00	Snap ring	挡圈 40	2	GB894.1-86	GB894.1-86
22	DK3P8-42191	01	Cylinder head sprocket seat	缸头链轮座	1		
23	B6150-00032	00	Snap ring 32	挡圈 32	1	GB894.1-86	GB894.1-86
24	HRLH1234021-N	02	Chain assembly	链条总成	2	See table,include 31-32	见附表,包含 31-32
25	B5050-00014	00	Washer	垫圈 14	2	GB93-87	GB93-87
26	B0530-14050	00	Bolt M14x1.5x50	螺栓 M14x1.5x50	2	GB5786-86	GB5786-86
27	B5310-00014	00	Washer	垫圈 14	2	GB97.1-85	GB97.1-85
28	DK3P8-41031	00	Stopper,chain	护链板	1	Without hoses & pulley block	不装胶管滑轮组
29	B0330-08020-X	00	Combined bolt	组合螺栓 M8x20	2	GB5783,GB 93-87	GB5783,GB 93-87
30	DK3H8-42011	01	Sheave	链轮	2		

HRDK2P8401-1 05 Front lift cylinder mounting

HRDK2P8401-1 05 前起升油缸安装图

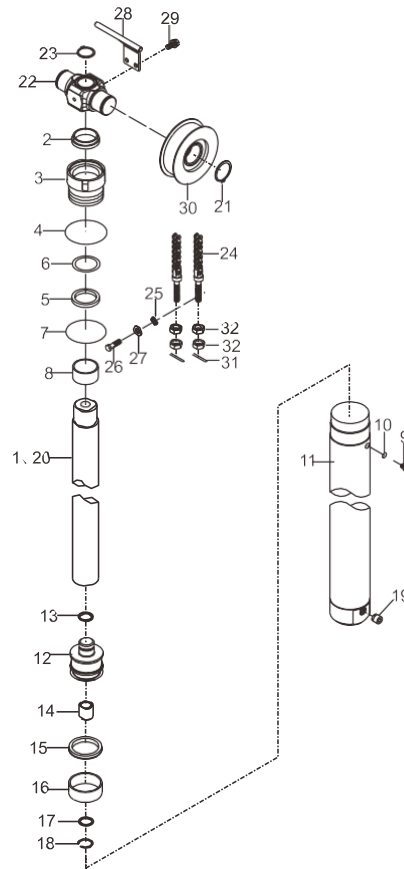

起升油缸安装选用件
LIFT CYLINDER MOUNTING OPTION TABLE

起升高度 LIFTING HEIGHT	起升油缸安装 LIFT CYLINDER	链条总成 CHAIN ASS'Y	备注 REMARK
360	DK2P8-40441	HRLH1234021-75	
400	DK2P8-40461	HRLH1234021-83	
435	DK2P8-40401	HRLH1234021-85	标准std
450	DK2P8-40481	HRLH1234021-87	
470	DK2P8-40491	HRLH1234021-91	
480	DK2P8-40541	HRLH1234021-93	
500	DK2P8-40521	HRLH1234021-97	
540	DK2P8-40541	HRLH1234021-103	
600	DK2P8-40561	HRLH1234021-113	
650	DK2P8-40581	HRLH1234021-125	
700	DK2P8-40601	HRLH1234021-133	
750	DK2P8-40621	HRLH1234021-143	

HRDK2P8401-2 05 Rear lift cylinder mounting

HRDK2P8401-2 05 后起升油缸安装图

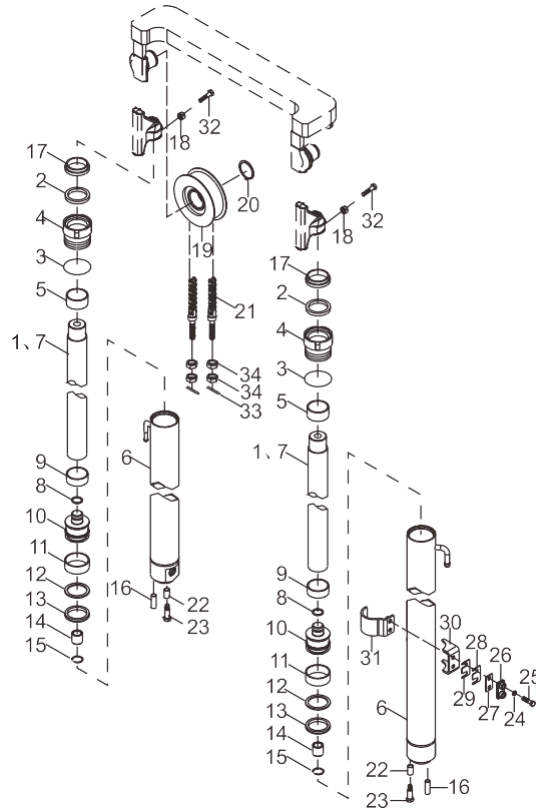

起升油缸安装选用件
 LIFT CYLINDER MOUNTING OPTION TABLE

起升高度 LIFTING HEIGHT	起升油缸左 LIFT CYLINDER L. H.	起升油缸右 LIFT CYLINDER R. H.	链条总成 CHAIN ASS'Y	备注 REMARK
360	DK2PB-40211L	DK2PB-40211R	HRLH1623011-61	
400	DK2PB-40221L	DK2PB-40221R	HRLH1623011-65	25
435 标准std	DK2PB-40201L	DK2PB-40201R	HRLH1623011-69	
450	DK2PB-40231L	DK2PB-40231R	HRLH1623011-71	
470	DK2PB-40241L	DK2PB-40241R	HRLH1623011-75	
480	DK2PB-40251L	DK2PB-40251R	HRLH1623011-77	
500	DK2PB-40261L	DK2PB-40261R	HRLH1623011-81	50
540	DK2PB-40271L	DK2PB-40271R	HRLH1623011-85	
600	DK2PB-40281L	DK2PB-40281R	HRLH1623011-93	
650	DK2PB-40291L	DK2PB-40291R	HRLH1623011-101	50
700	DK2PB-40301L	DK2PB-40301R	HRLH1623011-107	50
750	DK2PB-40311L	DK2PB-40311R	HRLH1623011-143	75

HRDK2P8401-2 05 Rear lift cylinder mounting

HRDK2P8401-2 05 后起升油缸安装图

序号 No.	零部件代号 Part No.	版本 Edition	名称 Part name		数量 Q'ty	备注 Remark	
1	HRDK2P8411	01	Rear lift cylinder	后起升油缸	2	See table,include 2-17	见附表,包含 2-17
2	23650-83521	00	U-shaped seal	U 型密封圈	2		
3	C00637	00	O-ring d49.7x2.4	O 型密封圈 d49.7x2.4	2		
4	GCQ050XS-01	00	Guide sleeve	导向套	2		
5	Z2113-04030	00	Bushing 4030	钢背轴承 4030	2		
6	DK2P8411.1-00	00	Cylinder body	缸体	2		
7	DK2P8411-01	00	Piston rod	活塞杆	2		
8	D20B8-42381	00	Snap ring	钢丝挡圈	2		
9	DK2P8411-02	00	Sleeve,adjusted	调整轴套	2	See table	见附表
10	GCQ050QR-03	00	Piston	活塞	2		
11	27970-53141	00	Wearing	孔用支撑环 50x45x20	2		
12	23650-83531	00	Catch 50x40x3	挡片 50x40x3	2		
13	23918-52161	00	U-ring	U 型圈	2		
14	GCQ055DL4-07	00	Sleeve	套	2		
15	GCQ055DL4-08	00	Snap ring	钢丝挡圈	2		
16	B3130-10026	00	Pin	销 B10x26	2	GB119-86	GB119-86
17	23650-83581	00	Dust ring	防尘圈	2		
18	B4123-00010	00	Nut	螺母 M10	2	GB6170-86	GB6170-86
19	DK3P8-42201	01	Sheave	链轮	2		
20	B6150-00040	00	Snap ring	挡圈 40	2	GB894.1-86	GB894.1-86
21	HRLH1623011-N	03	Chain	链条	2	See table,include 33-34	见附表,包含 33-34
22	D20B8-42031	01	Spacer	隔套	2		
23	B0530-12025	00	Bolt M12x1.25x25	螺栓 M12x1.25x25	2	GB5786-86	GB5786-86
24	B5050-00010	00	Washer	垫圈 10	4	GB93-87	GB93-87
25	B0230-10045	00	Bolt	螺栓 M10x45	4	GB5782-86	GB5782-86
26	DE778-42031	00	Cushion	减震块	2		
27	DE778-42071	00	Plate	垫板	2		
28	DE778-42051	00	Shim	调整垫片	2		
29	DE778-42061	00	Shim	调整垫片	2		
30	DE778-42021	00	Lock plate	卡板	2		

HRDK2P8401-2 05 Rear lift cylinder mounting

HRDK2P8401-2 05 后起升油缸安装图

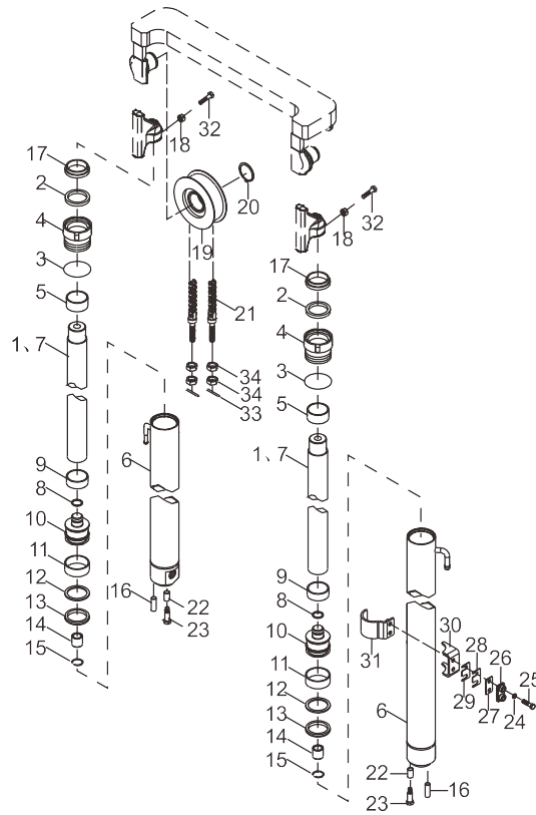

起升油缸安装选用件

LIFT CYLINDER MOUNTING OPTION TABLE

起升高度 LIFTING HEIGHT M363	起升油缸左 LIFT CYLINDER L. H.	起升油缸右 LIFT CYLINDER R. H.	链条总成 CHAIN ASS'Y	备注 REMARK
430	DK2PB-40211L	DK2PB-40211R	HRLH1623011-61	25
435 标准std	DK2PB-40201L	DK2PB-40201R	HRLH1623011-69	
450	DK2PB-40231L	DK2PB-40231R	HRLH1623011-71	
470	DK2PB-40241L	DK2PB-40241R	HRLH1623011-75	
480	DK2PB-40251L	DK2PB-40251R	HRLH1623011-77	
500	DK2PB-40261L	DK2PB-40261R	HRLH1623011-81	50
540	DK2PB-40271L	DK2PB-40271R	HRLH1623011-85	
630	DK2PB-40281L	DK2PB-40281R	HRLH1623011-93	
650	DK2PB-40291L	DK2PB-40291R	HRLH1623011-101	50
700	DK2PB-40301L	DK2PB-40301R	HRLH1623011-107	50
750	DK2PB-40311L	DK2PB-40311R	HRLH1623011-143	75

HRD20B8101 05 Fork

HRD20B8101 05 货叉总成

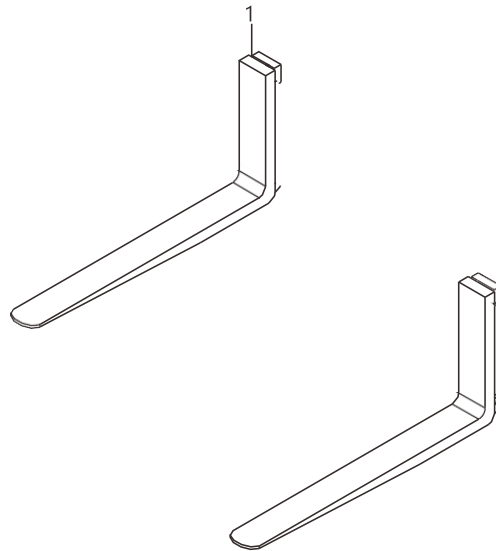

HRD20B8101 05 Fork							
HRD20B8101 05 货叉总成							
序号 No.	零部件代号 Part No.	版本 Edition	名称 Part name		数量 Q'ty	备注 Remark	
1	D20B8-10001G	05	2-2.5T Fork	2-2.5T 货叉	2	LF92-14A/920/2t Normal	LF92-14A/920/2t 标配
1	D20B8-10011G	05	2-2.5T Fork	2-2.5T 货叉	2	LF107-14A/1070/2.5t Normal	LF107-14A/1070/2.5t 标配
1	D20B8-10021G	05	2-2.5T Fork	2-2.5T 货叉	2	LF122-14A/1220	LF122-14A/1220
1	D20B8-10031G	05	2-2.5T Fork	2-2.5T 货叉	2	LF137-14A/1370	LF137-14A/1370
1	D20B8-10041G	05	2-2.5T Fork	2-2.5T 货叉	2	LF152-14A/1520	LF152-14A/1520
1	D20B8-10051G	05	2-2.5T Fork	2-2.5T 货叉	2	LF167-14A/1670	LF167-14A/1670
1	D20B8-10061G	05	2-2.5T Fork	2-2.5T 货叉	2	LF182-14A/1820	LF182-14A/1820
1	D20B8-10071G	05	2-2.5T Fork	2-2.5T 货叉	2	LF90-14A/900	LF90-14A/900
1	D20B8-10081G	05	2-2.5T Fork	2-2.5T 货叉	2	LF100-14A/1000	LF100-14A/1000
1	D20B8-10091G	05	2-2.5T Fork	2-2.5T 货叉	2	LF110-14A/1100	LF110-14A/1100
1	D20B8-10101G	05	2-2.5T Fork	2-2.5T 货叉	2	LF120-14A/1200	LF120-14A/1200
1	D20B8-10111G	05	2-2.5T Fork	2-2.5T 货叉	2	LF130-14A/1300	LF130-14A/1300
1	D20B8-10121G	05	2-2.5T Fork	2-2.5T 货叉	2	LF140-14A/1400	LF140-14A/1400
1	D20B8-10131G	05	2-2.5T Fork	2-2.5T 货叉	2	LF150-14A/1500	LF150-14A/1500
1	D20B8-10141G	05	2-2.5T Fork	2-2.5T 货叉	2	LF160-14A/1600	LF160-14A/1600
1	D20B8-10151G	05	2-2.5T Fork	2-2.5T 货叉	2	LF170-14A/1700	LF170-14A/1700
1	D20B8-10161G	05	2-2.5T Fork	2-2.5T 货叉	2	LF180-14A/1800	LF180-14A/1800
1	D20B8-10171G	05	2-2.5T Fork	2-2.5T 货叉	2	LF190-14A/1900	LF190-14A/1900
1	D20B8-10181G	05	2-2.5T Fork	2-2.5T 货叉	2	LF200-14A/2000	LF200-14A/2000

HRD2N38501 00 Tilt cylinder

HRD2N38501 00 倾斜油缸

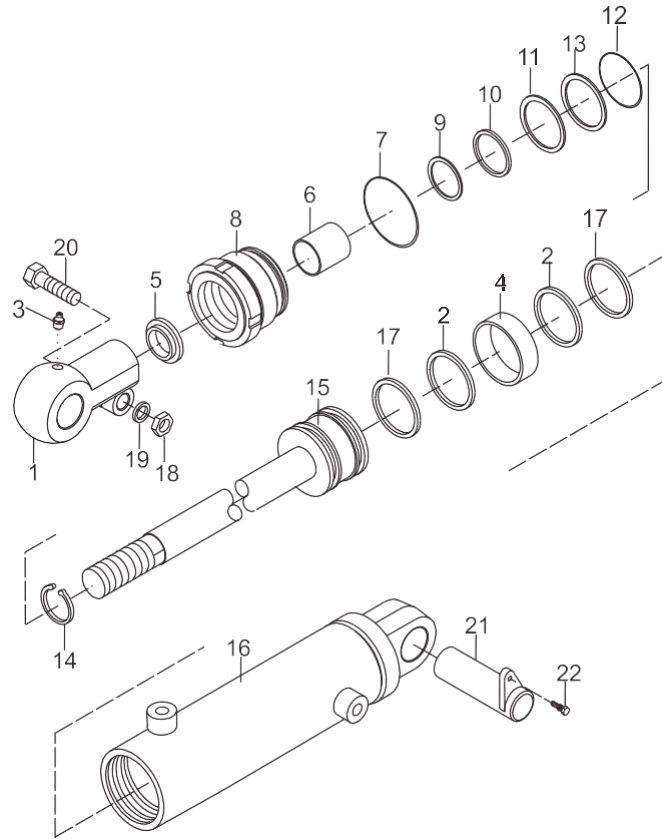

倾斜油缸选用件
TILT CYLINDER OPTION TABLE

前/后倾角 TILKT ANGLE	倾斜油缸左 TILT CYLINDER L. H.	倾斜油缸右 TILT CYLINDER R. H.
6°-12°	D2N38-50001	D2N38-50011
6°-10°	D2N38-50021	D2N38-50031
6°-6°	D2N38-50041	D2N38-50051
3°-6°	D2N38-50061	D2N38-50071
3°-3°	D2N38-50081	D2N38-50091

HRD2N38501 00 Tilt cylinder							
HRD2N38501 00 倾斜油缸							
序号 No.	零部件代号 Part No.	版本 Edition	名称 Part name		数量 Q'ty	备注 Remark	
1	HRD2MA8502-04	00	Ear ring	耳环	2		
2	D01D8-42051	00	Catch	挡片 70x60x3	4		
3	Q700B012C	00	Fitting	直通式滑脂嘴	1		
4	23678-52051	00	Wearing 70x65x2.5	支承环 70x65x2.5	2		
5	23468-52081	00	Dust ring	防尘圈 ϕ 52X ϕ 32X11X8	2		
6	Z2113-03225	00	Bushing	钢背轴承	2		
7	AG0075A	00	O-ring	O型密封圈 75x3.1	2	GB1235-76	GB1235-76
8	D7G58521-02	00	Guide sleeve	导向套	2		
9	23678-54001	00	Catch 48x32x3	挡片 48x32x3	2		
10	22228-50151A	00	Seal ring	轴用密封圈 32x48x10	2		
11	D20B8-52055	00	Catch 70x65.2x1.25	挡片 70x65.2x1.25	2		
12	OR64.4X3.1	00	O-ring D64.4x3.1	O型密封圈 D64.4x3.1	2	GB1235-76	GB1235-76
13	23678-54021S	00	Snap ring 52x43x2	挡圈 52x43x2	2		
14	B6052-00052	00	Snap ring	挡圈 52	2	GB893.1-86	GB893.1-86
15	D2N38501.2-00	00	Piston body assembly	活塞体	2		
16	D2N38501.1-00	00	Cylinder body	缸体	2		
17	23678-55001	00	U-ring	U型圈	4		
18	B4123-00014	00	Nut M14	螺母 M14	2	GB6170-86	GB6170-86
19	B5050-00014	00	Washer	垫圈 14	2	GB93-87	GB93-87
20	B0223-14055	00	Bolt	六角头螺栓 M14x55/35	2	GB5782-86	GB5782-86
21	D2MD8-00171A	00	Pin axle	倾斜油缸销轴总成	2		
22	B0530-10020-X1	00	Combined bolt M10x1.25x20	组合螺栓 M10x1.25x20	2	GB5786,GB93	GB5786,GB93

A1TP9-10001 01 Decal

A1TP9-10001 01 油漆标牌布置图 (中文)

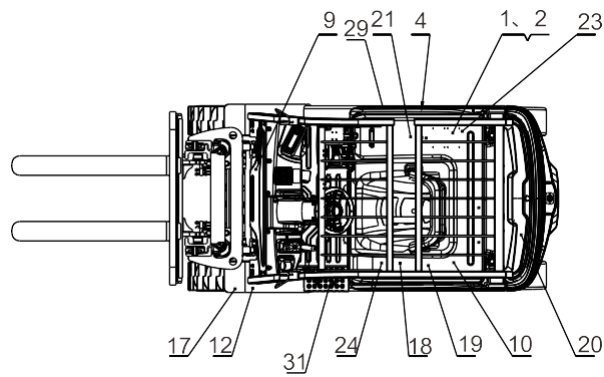
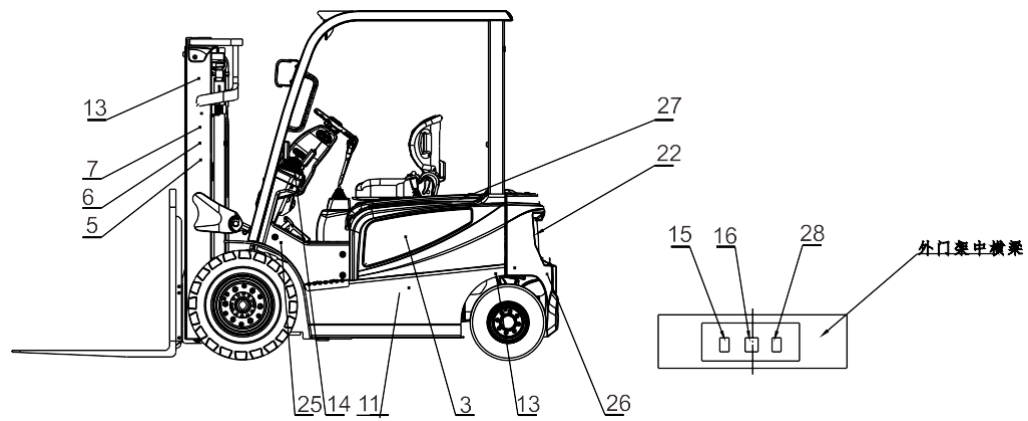

A1TP9-10001 01 Decal

A1TP9-10001 01 油漆标牌布置图 (中文)

序号 No.	零部件代号 Part No.	版本 Edition	名称 Part name		数量 Q'ty	备注 Remark	
1	6TY10-00-593	00	Battery counterweight forklift nameplate,Chinese	蓄电池平衡重式叉车铭牌(中文)	1		
2	6TY10-00-573	01	Actual bearing capacity nameplate	实际承载能力铭牌(中英文对照)	1		
3	6TY40-00-1450	00	H4 series 3.8t lithium battery forklift model signage (left)	H4 系列 3.8t 锂电池叉车型号标牌(左)	1	3.8 t use	3.8t 用
3	6TY40-00-1451	00	H4 series 3.5t lithium battery forklift model signage (left)	H4 系列 3.5t 锂电池叉车型号标牌(左)	1	For 3.5T	3.5t 用
3	6TY40-00-1452	00	H4 series 3.0t lithium battery forklift model signage (left)	H4 系列 3.0t 锂电池叉车型号标牌(左)	1	For 3.0T	3.0t 用
3	6TY40-00-1453	00	H4 series 2.5t lithium battery forklift model signage (left)	H4 系列 2.5t 锂电池叉车型号标牌(左)	1	For 2.5T	2.5t 用
3	6TY40-00-1454	00	H4 series 2.0t lithium battery forklift model signage (left)	H4 系列 2.0t 锂电池叉车型号标牌(左)	1	Web 2.0	2.0 用
3	6TY40-00-1455	00	H4 series small 2t lithium battery forklift model signage (left)	H4 系列小 2t 锂电池叉车型号标牌(左)	1	Small two is useless	小 2t 用
3	6TY40-00-1456	00	H4 series 1.8t lithium battery forklift model signage (left)	H4 系列 1.8t 锂电池叉车型号标牌(左)	1	For 1.8t	1.8t 用
3	6TY40-00-1457	00	H4 series 1.5t lithium battery forklift model signage (left)	H4 系列 1.5t 锂电池叉车型号标牌(左)	1	For 1.5t	1.5t 用
4	6TY40-00-1458	00	H4 series 3.8t lithium battery forklift model signage (right)	H4 系列 3.8t 锂电池叉车型号标牌(右)	1	3.8 t use	3.8t 用
4	6TY40-00-1459	00	H4 series 3.5t lithium battery forklift model signage (right)	H4 系列 3.5t 锂电池叉车型号标牌(右)	1	For 3.5T	3.5t 用
4	6TY40-00-1460	00	H4 series 3.0t lithium battery forklift model signage (right)	H4 系列 3.0t 锂电池叉车型号标牌(右)	1	For 3.0T	3.0t 用
4	6TY40-00-1461	00	H4 series 2.5t lithium battery forklift model signage (right)	H4 系列 2.5t 锂电池叉车型号标牌(右)	1	For 2.5T	2.5t 用
4	6TY40-00-1462	00	H4 series 2.0t lithium battery forklift model signage (right)	H4 系列 2.0t 锂电池叉车型号标牌(右)	1	For 2.0t	2.0t 用
4	6TY40-00-1463	00	H4 series small 2t lithium battery forklift model signage (right)	H4 系列小 2t 锂电池叉车型号标牌(右)	1	Small two is useless	小 2t 用
4	6TY40-00-1464	00	H4 series 1.8t lithium battery forklift model signage (right)	H4 系列 1.8t 锂电池叉车型号标牌(右)	1	For 1.8t	1.8t 用
4	6TY40-00-1465	00	H4 series 1.5t lithium battery forklift model signage (right)	H4 系列 1.5t 锂电池叉车型号标牌(右)	1	For 1.5t	1.5t 用
5	6TY20-00-1047	00	Load curve sign	负荷曲线标牌(G2 锂电专用车 3.8t 二节门架)	1	For 3.8t 2-stage mast	3.8t 二节门架用
5	6TY20-00-1048	00	Load curve sign	负荷曲线标牌(G2 锂电专用车 3.8t 三节门架)	1	For 3.8t 3-stage mast	3.8t 三节门架用
5	6TY20-00-746	00	Decal	负荷曲线标贴	1	For 3.5T,2-stage mast	3.5t 二节门架用
5	6TY20-00-747	00	Decal	负荷曲线标贴	1	For 3.5T,3-stage mast	3.5t 三节门架用

A1TP9-10001 01 Decal

A1TP9-10001 01 油漆标牌布置图 (中文)

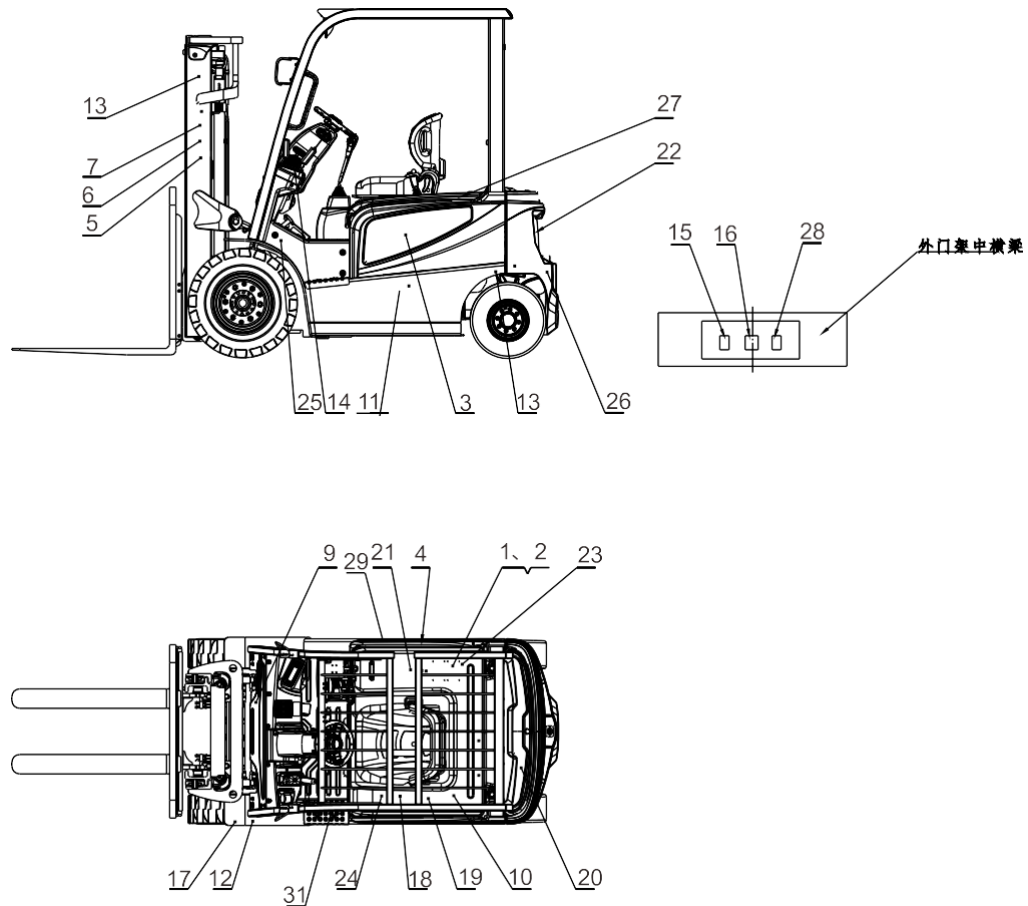

A1TP9-10001 01 Decal

A1TP9-10001 01 油漆标牌布置图 (中文)

序号 No.	零部件代号 Part No.	版本 Edition	名称 Part name		数量 Q'ty	备注 Remark	
5	6TY20-00-898	00	Plate,capacity chart	负荷曲线图 (G2 系列 锂电专用车 3.5t 二节门 架)	1	For 3.5T,2- stage mast	3.5t 二节门 架用
5	6TY20-00-900	00	Plate,capacity chart	负荷曲线图 (G2 系列 锂电专用车 3.5t 三节门 架)	1	For 3.5T,3- stage mast	3.5t 三节门 架用
5	6TY20-00-744	00	Decal	负荷曲线标贴	1	For 3.0T,2- stage mast	3.0t 二节门 架用
5	6TY20-00-745	00	Decal	负荷曲线标贴	1	For 3.0T,3- stage mast	3.0t 三节门 架用
5	6TY20-00-897	00	Plate,capacity chart	负荷曲线图 (G2 系列 锂电专用车 3.0t 二节门 架)	1	For 3.0T,2- stage mast	3.0t 二节门 架用
5	6TY20-00-899	00	Plate,capacity chart	负荷曲线图 (G2 系列 锂电专用车 3.0t 三节门 架)	1	For 3.0T,3- stage mast	3.0t 三节门 架用
5	6TY20-00-908	00	Plate,capacity chart	负荷曲线图 (G2 系列 锂电专用车 2.5t 二节门 架)	1	For 2.5t 2- stage mast	2.5t 二节门 架用
5	6TY20-00-910	00	Plate,capacity chart	负荷曲线图 (G2 系列 锂电专用车 2.5t 三节门 架)	1	For 2.5t 3- stage mast	2.5t 三节门 架用
5	6TY20-00-911	00	Plate,capacity chart	负荷曲线图 (G2 系列 锂电专用车 2.0t 二节门 架)	1	For 2.0t 2- stage mast	2.0t 二节门 架用
5	6TY20-00-909	00	Plate,capacity chart	负荷曲线图 (G2 系列 锂电专用车 2.0t 三节门 架)	1	For 2.0t 3- stage mast	2.0t 三节门 架用
5	6TY20-00-1051	00	Load curve label (light type 2t), STD or full free 2-stage mast	负荷曲线标牌(小 2t),标 准或两节全自由门架	1	Small two is useless	小 2t 用
5	6TY20-00-1052	00	Load curve sign (light type 2t),full free 3- stage mast	负荷曲线标牌(小 2t),三 节全自由门架	1	Small two is useless	小 2t 用
5	6TY20-00-1028	00	Load curve label (1.8t),STD or full free 2-stage mast	负荷曲线标牌(1.8t),标 准或两节全自由门架	1	For 1.8t	1.8t 用
5	6TY20-00-1029	00	Load curve sign (1.8t),full free 3-stage mast	负荷曲线标牌(1.8t),三 节全自由门架	1	For 1.8t	1.8t 用
5	6TY20-00-1026	00	Load curve label (1.5t),STD or full free 2-stage mast	负荷曲线标牌(1.5t),标 准或两节全自由门架	1	For 1.5t	1.5t 用
5	6TY20-00-1027	00	Load curve sign (1.5t),full free 3-stage mast	负荷曲线标牌(1.5t),三 节全自由门架	1	For 1.5t	1.5t 用
6	6TY40-00-632	00	combined label	合力标贴	2		
7	6TY40-01-79	00	Plate,safety	安全标志标牌	1		
8	6TY40-01-80	00	Plate,safety	安全标志标牌 (右)	1		
9	6TY40-02-105	00	Plate,lubrication system,electric,Chines e	润滑系统图标牌电动(中 文)	1		
10	6TY40-03-132	00	Plate,notice for use,electric,Chinese	使用须知标牌电动(中 文)	1		
11	6TY40-05-45	00	Add hydraulic oil sign	加液压油标牌(中文)	1		
12	6TY40-08-46	00	Tyre safety plate	轮胎安全标牌(中文)	1		

A1TP9-10001 01 Decal

A1TP9-10001 01 油漆标牌布置图 (中文)

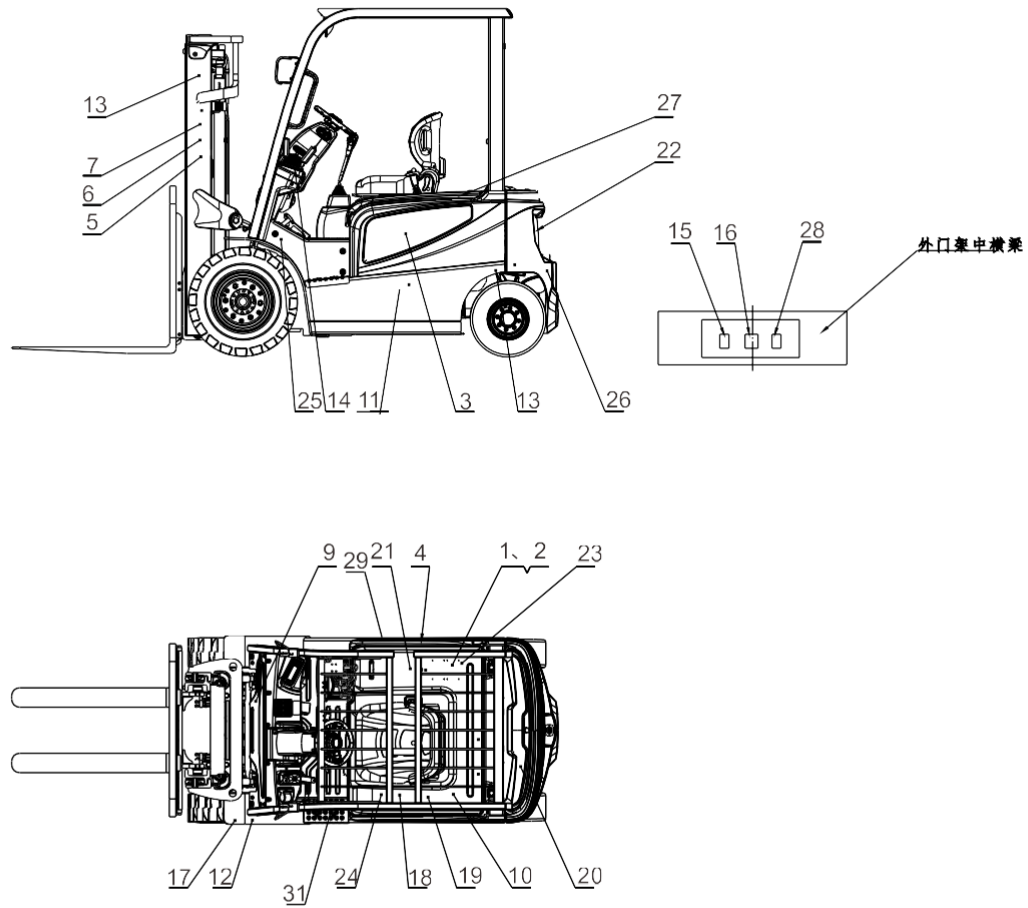

A1TP9-10001 01 Decal

A1TP9-10001 01 油漆标牌布置图 (中文)

序号 No.	零部件代号 Part No.	版本 Edition	名称 Part name		数量 Q'ty	备注 Remark	
13	6TY40-10-45	00	Hoisting plate	起吊标牌	4		
14	6TY40-13-51	00	Decal	停车制动调整标牌(中文)	1		
15	6TY40-14-35	00	Plate,padlok mast space	禁止进入门架后空间	1		
16	6TY40-15-40	00	Decal,notice thumb hand	注意伤手标牌	1		
17	6TY40-16-414	00	Tire pressure plate	轮胎气压标牌 (中文)	1	3.8 t use	3.8t 用
17	6TY40-16-332	00	Tire pressure plate	轮胎气压标牌	1	3-3.5t	3-3.5t 用
17	6TY40-16-289	01	2-2.5t Plate,air pressure	2-2.5t 轮胎气压 (中文)	1	2-2.5 t	2-2.5t 用
17	6TY40-16-431	00	Tire pressure plate	轮胎气压标牌 (中文)	1	1.5-1.8t	1.5-1.8t 用
17	6TY40-16-366	00	Tire pressure plate	轮胎气压标牌 (G2 系列 1-1.8t)	1	Small two is useless	小 2t 用
18	6TY40-20-37	00	Notice signs for lithium batteries,Chinese	锂电池使用注意事项标牌(中文)	1		
19	6TY40-30-19	00	Lithium battery maintenance notice sign,Chinese	锂电池保养注意事项标牌(中文)	1		
20	6TY40-34-27	00	Forbiding filling water model	严禁冲水标牌(中文)	1		
21	6TY40-88-09	00	Decal	急停开关警示标牌(中文)	1		
22	6TY40-185-45	00	H4 series standard lithium electric car tail sticker (with characters)	H4 系列标准型锂电车尾标贴 (带字)	1	For standard models	标准型用
22	6TY40-185-46	00	H4 series power type lithium electric vehicle tail sticker (with characters)	H4 系列动力型锂电车尾标贴 (带字)	1	For power model	动力型用
23	B2391-04008	00	Rivet	开口型铆钉 4x8	8		
24	6TY40-176-01	00	WeChat QR code sticker	“合力叉车” 微信二维码标贴	1		
25	6TY40-172-17	00	Brake liquid adding plate	加注制动液标牌	1		
26	FZ-FZK3572	00	Block	防撞块	5		
27	6TY40-108-26	00	Plate,shock absorber safety lock	气弹簧安全锁标牌(中文)	1		
28	6TY40-01-86	00	Precautions for high position operation	高位作业注意事项	1		
29	6TY40-181-09	00	Lithium battery charging interface sticker	锂电池充电接口标贴	1		
30	6TY40-11-06	02	Decal	“合力锂电” 标贴	2		
31	6TY40-115-17	00	Safety belt sign	安全带标牌	1		

A1TP9-10011 01 Decal

A1TP9-10011 01 油漆标牌布置图

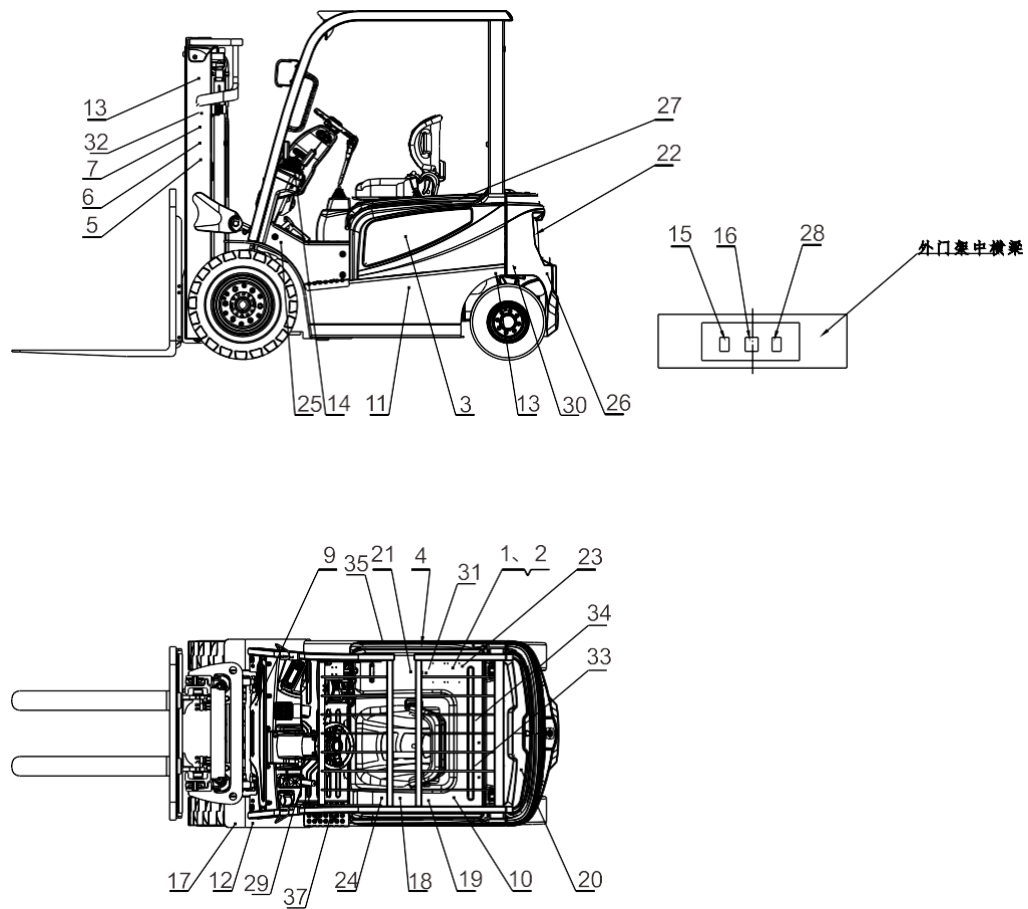

A1TP9-10011 01 Decal

A1TP9-10011 01 油漆标牌布置图

序号 No.	零部件代号 Part No.	版本 Edition	名称 Part name		数量 Q'ty	备注 Remark	
1	6TY10-00-595	01	Battery counterweight forklift nameplate, English	蓄电池平衡重叉车铭牌(英文)	1	packaging	合力包装
1	6TY10-00-650	00	Plate, counterweight	蓄电池平衡重叉车铭牌(中性包装)	1	Neutral Packing	中性包装
2	6TY10-00-594	00	Plate, actual carrying capacity, small tonnage, English	实际承载能力铭牌小吨位(英文)	1	packaging	合力包装
2	6TY10-00-651	00	Name plate	门架实际承载能力铭牌(中性包装)	1	Neutral Packing	中性包装
3	6TY40-00-1450	00	H4 series 3.8t lithium battery forklift model signage (left)	H4 系列 3.8t 锂电池叉车型号标牌(左)	1	3.8 t use	3.8t 用
3	6TY40-00-1451	00	H4 series 3.5t lithium battery forklift model signage (left)	H4 系列 3.5t 锂电池叉车型号标牌(左)	1	For 3.5T	3.5t 用
3	6TY40-00-1452	00	H4 series 3.0t lithium battery forklift model signage (left)	H4 系列 3.0t 锂电池叉车型号标牌(左)	1	For 3.0T	3.0t 用
3	6TY40-00-1453	00	H4 series 2.5t lithium battery forklift model signage (left)	H4 系列 2.5t 锂电池叉车型号标牌(左)	1	For 2.5T	2.5t 用
3	6TY40-00-1454	00	H4 series 2.0t lithium battery forklift model signage (left)	H4 系列 2.0t 锂电池叉车型号标牌(左)	1	Web 2.0	2.0 用
3	6TY40-00-1455	00	H4 series small 2t lithium battery forklift model signage (left)	H4 系列小 2t 锂电池叉车型号标牌(左)	1	Small two is useless	小 2t 用
3	6TY40-00-1456	00	H4 series 1.8t lithium battery forklift model signage (left)	H4 系列 1.8t 锂电池叉车型号标牌(左)	1	For 1.8t	1.8t 用
3	6TY40-00-1457	00	H4 series 1.5t lithium battery forklift model signage (left)	H4 系列 1.5t 锂电池叉车型号标牌(左)	1	For 1.5t	1.5t 用
4	6TY40-00-1458	00	H4 series 3.8t lithium battery forklift model signage (right)	H4 系列 3.8t 锂电池叉车型号标牌(右)	1	3.8 t use	3.8t 用
4	6TY40-00-1459	00	H4 series 3.5t lithium battery forklift model signage (right)	H4 系列 3.5t 锂电池叉车型号标牌(右)	1	For 3.5T	3.5t 用
4	6TY40-00-1460	00	H4 series 3.0t lithium battery forklift model signage (right)	H4 系列 3.0t 锂电池叉车型号标牌(右)	1	For 3.0T	3.0t 用
4	6TY40-00-1461	00	H4 series 2.5t lithium battery forklift model signage (right)	H4 系列 2.5t 锂电池叉车型号标牌(右)	1	For 2.5T	2.5t 用
4	6TY40-00-1462	00	H4 series 2.0t lithium battery forklift model signage (right)	H4 系列 2.0t 锂电池叉车型号标牌(右)	1	For 2.0t	2.0t 用
4	6TY40-00-1463	00	H4 series small 2t lithium battery forklift model signage (right)	H4 系列小 2t 锂电池叉车型号标牌(右)	1	Small two is useless	小 2t 用
4	6TY40-00-1464	00	H4 series 1.8t lithium battery forklift model signage (right)	H4 系列 1.8t 锂电池叉车型号标牌(右)	1	For 1.8t	1.8t 用
4	6TY40-00-1465	00	H4 series 1.5t lithium battery forklift model signage (right)	H4 系列 1.5t 锂电池叉车型号标牌(右)	1	For 1.5t	1.5t 用
6	6TY40-00-632	00	combined label	合力标贴	2	packaging	合力包装
7	6TY40-01-79	00	Plate, safety	安全标志标牌	1		
8	6TY40-01-80	00	Plate, safety	安全标志标牌(右)	1		
9	6TY40-02-106	00	Plate, lubrication system icon, electric, English	润滑系统图标牌电动(英文)	1		

A1TP9-10011 01 Decal

A1TP9-10011 01 油漆标牌布置图 (英文)

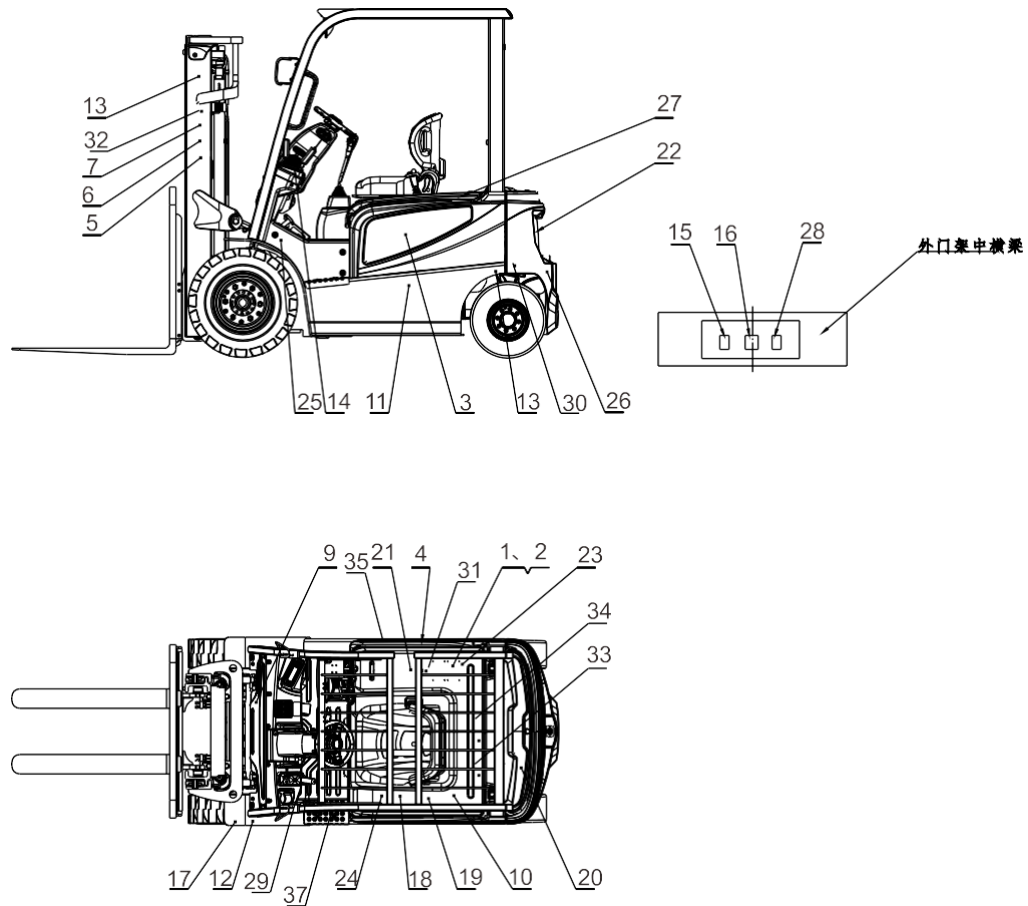

A1TP9-10011 01 Decal

A1TP9-10011 01 油漆标牌布置图 (英文)

序号 No.	零部件代号 Part No.	版本 Edition	名称 Part name		数量 Q'ty	备注 Remark	
10	6TY40-03-133	01	Pedal	使用须知标牌电动(英文)	1		
11	6TY40-05-46	01	Add hydraulic oil sign	加液压油标牌(英文)	1		
12	6TY40-08-47	01	Tyre safety plate	轮胎安全标牌(英文)	1		
13	6TY40-10-45	00	Hoisting plate	起吊标牌	4		
14	6TY40-13-52	00	Plate,parking brake adjust	停车制动调整标牌(英文)	1		
15	6TY40-14-35	00	Plate,padlok mast space	禁止进入门架后空间	1		
16	6TY40-15-40	00	Decal,notice thumb hand	注意伤手标牌	1		
17	6TY40-16-415	00	Tire pressure plate	轮胎气压标牌(英文)	1	3.8 t use	3.8t 用
17	6TY40-16-333	00	Tire pressure plate	轮胎气压标牌 (英文)	1	3-3.5t	3-3.5t 用
17	6TY40-16-290	01	2-2.5t Plate,air pressure	2-2.5t 轮胎气压 (英文)	1	2-2.5 t	2-2.5t 用
17	6TY40-16-432	00	Tire pressure plate	轮胎气压标牌 (英文)	1	1.5-1.8t	1.5-1.8t 用
17	6TY40-16-370	00	1-1.8t Tire pressure plate	1-1.8t 轮胎气压标牌 (英文)	1	Small two is useless	小 2t 用
18	6TY40-20-38	01	Notice signs for lithium batteries,English	锂电池使用注意事项标牌(英文)	1		
19	6TY40-30-20	01	Lithium battery maintenance notice sign,English	锂电池保养注意事项标牌(英文)	1		
20	6TY40-34-28	01	Forbiding filling water model	严禁冲水标牌(英文)	1		
21	6TY40-88-10	01	Decal	急停开关警示标牌(英文)	1		
22	6TY40-185-45	00	H4 series standard lithium electric car tail sticker (with characters)	H4 系列标准型锂电车尾标贴 (带字)	1	For standard models	标准型用
22	6TY40-185-47	01		H4 系列标准型锂电车尾标贴 (无字)	1	Neutral packaging, standard type	中性包装、标准型用
22	6TY40-185-46	00	H4 series power type lithium electric vehicle tail sticker (with characters)	H4 系列动力型锂电车尾标贴 (带字)	1	For power model	动力型用
22	6TY40-185-48	01		H4 系列动力型锂电车尾标贴 (无字)	1	Neutral packaging, power type	中性包装、动力型用
23	B2391-04008	00	Rivet	开口型铆钉 4x8	8		
25	6TY40-172-17	00	Brake liquid adding plate	加注制动液标牌	1		
27	6TY40-108-26	00	Plate,shock absorber safety lock	气弹簧安全锁标牌(中文)	1		
28	6TY40-01-88	00	Precautions for high position operation(english)	高位作业注意事项 (英文)	1		
29	6TY40-121-14	00	Decal, English	离开制动标贴(英文)	1		
30	6TY40-120-12	01	Plate,capacity chart	捆绑点标识(英文)	3		
31	6TY40-104-02	00	Plate	紧急断电开关背景标牌	1		

A1TP9-10011 01 Decal

A1TP9-10011 01 油漆标牌布置图

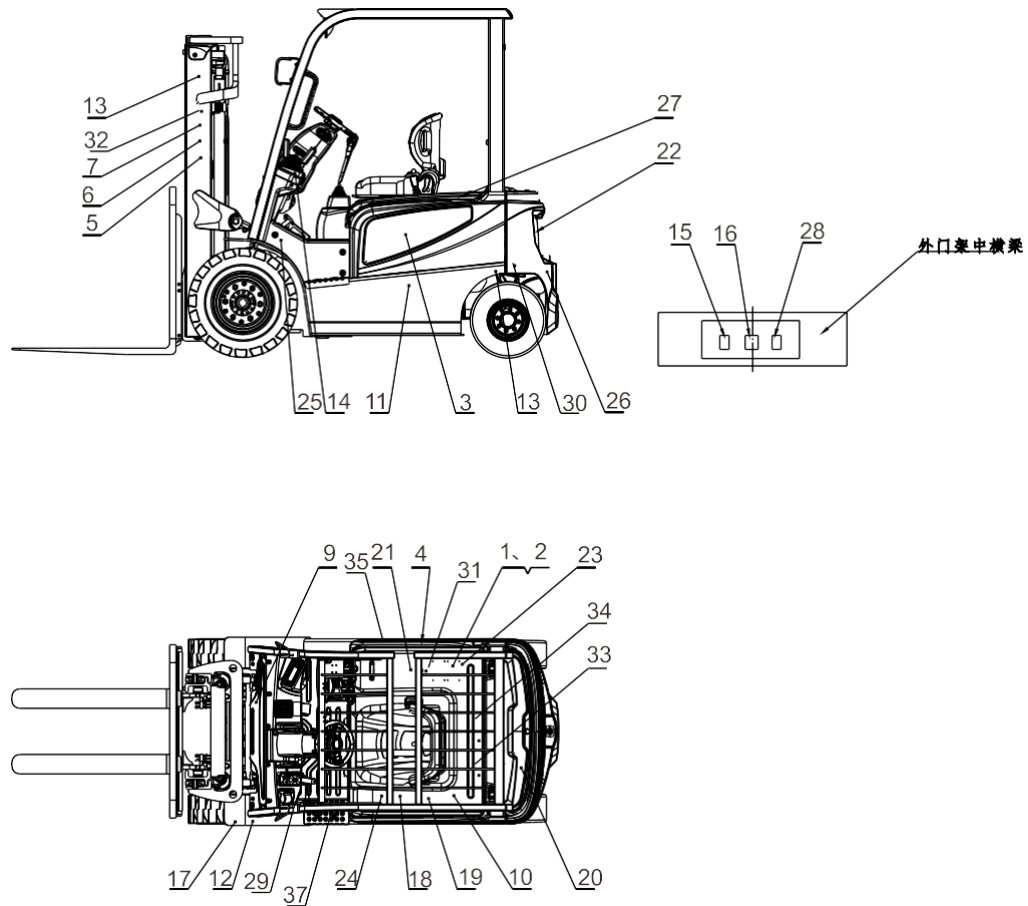

HRD9FL8701 05 Hose pulley block (metric)							
HRD9FL8701 05 胶管滑轮组(公制)							
序号 No.	零部件代号 Part No.	版本 Edition	名称 Part name		数量 Q'ty	备注 Remark	
1	D9FL8-72021	02	Pulley bracket	滑轮支架	2	Four piece valve	四片阀
1	D9FL8-72021	02	Pulley bracket	滑轮支架	1	Three piece valve	三片阀
2	B0330-08020	00	Bolt	螺栓 M8x20	2	Three piece valve,GB5783-86	三片阀,GB5783-86
2	B0330-08020	00	Bolt	螺栓 M8x20	4	Four piece valve	四片阀
3	B5050-00008	00	Washer	垫圈 8	2	Three piece valve,GB93-87	三片阀,GB93-87
3	B5050-00008	00	Washer	垫圈 8	4	Four piece valve	四片阀
4	D9FL8-72011	01	Pulley	滑轮	2	Four piece valve	四片阀
4	D9FL8-72011	01	Pulley	滑轮	1	Three piece valve	三片阀
5	B6150-00020	00	Snap ring	挡圈 20	2	Four piece valve	四片阀
5	B6150-00020	00	Snap ring	挡圈 20	1	Three piece valve,GB894.1-86	三片阀,GB894.1-86
6	D16JH-05221	05	Double row pipe clamp	双列管夹	2	Four piece valve	四片阀
6	D16JH-05221	05	Double row pipe clamp	双列管夹	1	Three piece valve	三片阀
7	B0230-06030	00	Bolt	螺栓 M6x30	2	Three piece valve,GB5782-86	三片阀,GB5782-86
7	B0230-06030	00	Bolt	螺栓 M6x30	4	Four piece valve	四片阀
8	B5050-00006	00	Washer,lock	垫圈 6	2	Three piece valve,GB93-87	三片阀,GB93-87
8	B5050-00006	00	Washer,lock	垫圈 6	4	Four piece valve	四片阀
9	Z9260-80350	00	8 x350 strapping tape	捆扎带 8x350	2	Three piece valve	三片阀
9	Z9260-80350	00	8 x350 strapping tape	捆扎带 8x350	4	Four piece valve	四片阀
10	F23JH-22041	00	Pipe clamp	管夹	4	Four piece valve	四片阀
10	F23JH-22041	00	Pipe clamp	管夹	2	Three piece valve	三片阀
11	Z9702-1025516	00	Hose H.P.	高压胶管	4	Four piece valve	四片阀
11	Z9702-1025516	00	Hose H.P.	高压胶管	2	Three piece valve, see table	三片阀,见表
12	Z9702-1027516	00	Hose H.P.	高压胶管	2	Four piece valve, see table	四片阀,见表
13	B0330-08025	00	Bolt	螺栓 M8x25	1	Three piece valve,GB5783-86	三片阀,GB5783-86
13	B0330-08025	00	Bolt	螺栓 M8x25	2	Four piece valve	四片阀
14	B5050-00008	00	Washer	垫圈 8	1	Three piece valve,GB93-87	三片阀,GB93-87
14	B5050-00008	00	Washer	垫圈 8	2	Four piece valve	四片阀

HRD9FL8702 01 Rubber hose pulley block (USA)

HRD9FL8702 01 胶管滑轮组 (美制)

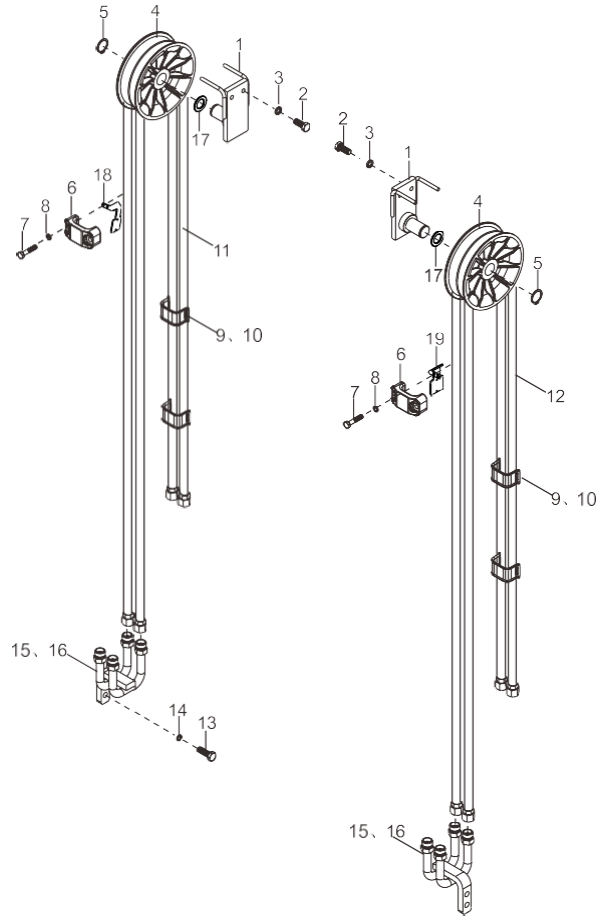

胶管滑轮组选用件
HOSE & PULLEY BLOCK OPTION TABLE

起升高度 LIFTING HEIGHT	件11 NO. 11				件12 NO. 12			
	2-2.5t	3t	3.5t	3.8t	2-2.5t	3t	3.5t	3.8t
200	Z7802-1025516	Z7802-1026516	Z7802-1027516	Z7802-1029016	Z7802-1027516	Z7802-1028516	Z7802-1029516	Z7802-1031016
225	Z7802-1028016	Z7802-1029016	Z7802-1030016	Z7802-1031516	Z7802-1030016	Z7802-1031016	Z7802-1032016	Z7802-1033516
250	Z7802-1030516	Z7802-1031516	Z7802-1032516	Z7802-1034016	Z7802-1032516	Z7802-1033516	Z7802-1034516	Z7802-1036016
270	Z7802-1032516	Z7802-1033516	Z7802-1034516	Z7802-1036016	Z7802-1034516	Z7802-1035516	Z7802-1036516	Z7802-1038016
300	Z7802-1035516	Z7802-1036516	Z7802-1037516	Z7802-1039016	Z7802-1037516	Z7802-1038516	Z7802-1039516	Z7802-1041016
330	Z7802-1038516	Z7802-1039516	Z7802-1040516	Z7802-1042016	Z7802-1040516	Z7802-1041516	Z7802-1042516	Z7802-1044016
350	Z7802-1040516	Z7802-1041516	Z7802-1042516	Z7802-1044016	Z7802-1042516	Z7802-1043516	Z7802-1044516	Z7802-1046016
370	Z7802-1042516	Z7802-1043516	Z7802-1044516	Z7802-1046016	Z7802-1044516	Z7802-1045516	Z7802-1046516	Z7802-1048016
400	Z7802-1046016	Z7802-1047016	Z7802-1048016	Z7802-1049516	Z7802-1048016	Z7802-1049016	Z7802-1050016	Z7802-1051516
425	Z7802-1048516	Z7802-1049516	Z7802-1050516	Z7802-1052016	Z7802-1050516	Z7802-1051516	Z7802-1052516	Z7802-1054016
450	Z7802-1051016	Z7802-1052016	Z7802-1053016	Z7802-1054516	Z7802-1053016	Z7802-1054016	Z7802-1055016	Z7802-1056516
475	Z7802-1053516	Z7802-1054516	Z7802-1055516	Z7802-1057016	Z7802-1055516	Z7802-1056516	Z7802-1057516	Z7802-1059016
500	Z7802-1056016	Z7802-1057016	Z7802-1058016	Z7802-1059516	Z7802-1058016	Z7802-1059016	Z7802-1060016	Z7802-1061516
550	Z7802-1062016	Z7802-1063016	Z7802-1064016	Z7802-1065516	Z7802-1064016	Z7802-1065016	Z7802-1066016	Z7802-1067516
600	Z7802-1067016	Z7802-1068016	Z7802-1069016	Z7802-1070516	Z7802-1069016	Z7802-1070016	Z7802-1071016	Z7802-1072516

HRD9FL8702 01 Rubber hose pulley block (USA)

HRD9FL8702 01 胶管滑轮组 (美制)

序号 No.	零部件代号 Part No.	版本 Edition	名称 Part name		数量 Q'ty	备注 Remark	
1	D9FL8-72021	02	Pulley bracket	滑轮支架	2	Four piece valve	四片阀
1	D9FL8-72021	02	Pulley bracket	滑轮支架	1	Three piece valve	三片阀
2	B0330-08020	00	Bolt	螺栓 M8x20	2	Three piece valve,GB5783-86	三片阀,GB5783-86
2	B0330-08020	00	Bolt	螺栓 M8x20	4	Four piece valve	四片阀
3	B5050-00008	00	Washer	垫圈 8	2	Three piece valve,GB93-87	三片阀,GB93-87
3	B5050-00008	00	Washer	垫圈 8	4	Four piece valve	四片阀
4	D9FL8-72011	01	Pulley	滑轮	2	Four piece valve	四片阀
4	D9FL8-72011	01	Pulley	滑轮	1	Three piece valve	三片阀
5	B6150-00020	00	Snap ring	挡圈 20	2	Four piece valve	四片阀
5	B6150-00020	00	Snap ring	挡圈 20	1	Three piece valve,GB894.1-86	三片阀,GB894.1-86
6	D16JH-05221	05	Double row pipe clamp	双列管夹	2	Four piece valve	四片阀
6	D16JH-05221	05	Double row pipe clamp	双列管夹	1	Three piece valve	三片阀
7	B0230-06030	00	Bolt	螺栓 M6x30	2	Three piece valve,GB5782-86	三片阀,GB5782-86
7	B0230-06030	00	Bolt	螺栓 M6x30	4	Four piece valve	四片阀
8	B5050-00006	00	Washer,lock	垫圈 6	2	Three piece valve,GB93-87	三片阀,GB93-87
8	B5050-00006	00	Washer,lock	垫圈 6	4	Four piece valve	四片阀
9	Z9260-80350	00	8 x350 strapping tape	捆扎带 8x350	2	Three piece valve	三片阀
9	Z9260-80350	00	8 x350 strapping tape	捆扎带 8x350	4	Four piece valve	四片阀
10	F23JH-22041	00	Pipe clamp	管夹	4	Four piece valve	四片阀
10	F23JH-22041	00	Pipe clamp	管夹	2	Three piece valve	三片阀
11	Z7802-1000016	00	Hose H.P.	高压胶管	4	Four piece valve	四片阀
11	Z7802-1000016	00	Hose H.P.	高压胶管	2	Three piece valve, see table	三片阀,见表
12	Z7802-1000016	00	Hose H.P.	高压胶管	2	Four piece valve, see table	四片阀,见表
13	B0330-08025	00	Bolt	螺栓 M8x25	1	Three piece valve,GB5783-86	三片阀,GB5783-86
13	B0330-08025	00	Bolt	螺栓 M8x25	2	Four piece valve	四片阀
14	B5050-00008	00	Washer	垫圈 8	1	Three piece valve,GB93-87	三片阀,GB93-87
14	B5050-00008	00	Washer	垫圈 8	2	Four piece valve	四片阀

HRD9FL8702 01 Rubber hose pulley block (USA)

HRD9FL8702 01 胶管滑轮组 (美制)

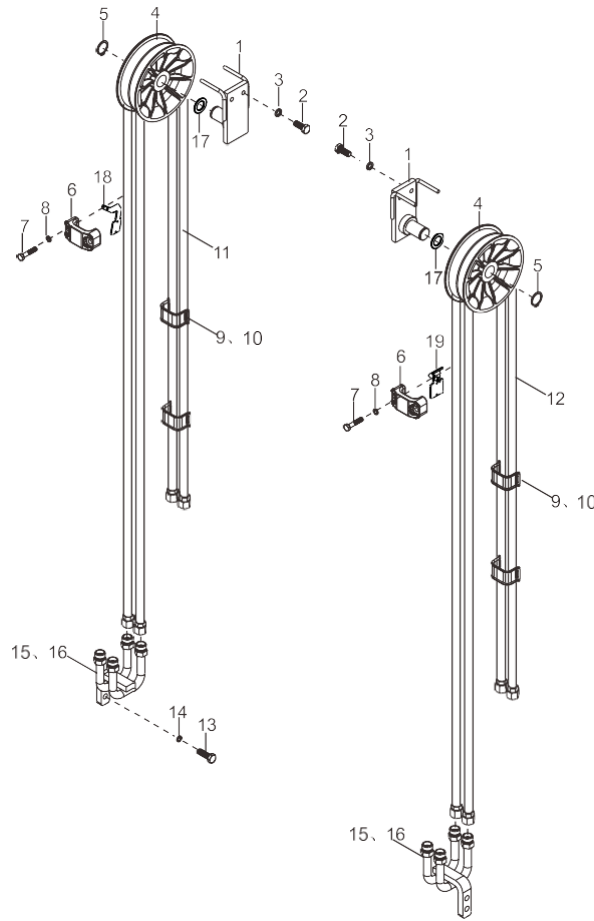

胶管滑轮组选用件
 HOSE & PULLEY BLOCK OPTION TABLE

起升高度 LIFTING HEIGHT	件11 NO 11				件12 NO 12			
	2-2.5t	3t	3.5t	3.8t	2-2.5t	3t	3.5t	3.8t
200	Z7802-1025516	Z7802-1026516	Z7802-1027516	Z7802-1029016	Z7802-1027516	Z7802-1028516	Z7802-1029516	Z7802-1031016
225	Z7802-1028016	Z7802-1029016	Z7802-1030016	Z7802-1031516	Z7802-1030016	Z7802-1031016	Z7802-1032016	Z7802-1033516
250	Z7802-1030516	Z7802-1031516	Z7802-1032516	Z7802-1034016	Z7802-1032516	Z7802-1033516	Z7802-1034516	Z7802-1036016
270	Z7802-1032516	Z7802-1033516	Z7802-1034516	Z7802-1036016	Z7802-1034516	Z7802-1035516	Z7802-1036516	Z7802-1038016
300	Z7802-1035516	Z7802-1036516	Z7802-1037516	Z7802-1039016	Z7802-1037516	Z7802-1038516	Z7802-1039516	Z7802-1041016
330	Z7802-1038516	Z7802-1039516	Z7802-1040516	Z7802-1042016	Z7802-1040516	Z7802-1041516	Z7802-1042516	Z7802-1044016
350	Z7802-1040516	Z7802-1041516	Z7802-1042516	Z7802-1044016	Z7802-1042516	Z7802-1043516	Z7802-1044516	Z7802-1046016
370	Z7802-1042516	Z7802-1043516	Z7802-1044516	Z7802-1046016	Z7802-1044516	Z7802-1045516	Z7802-1046516	Z7802-1048016
400	Z7802-1046016	Z7802-1047016	Z7802-1048016	Z7802-1049516	Z7802-1048016	Z7802-1049016	Z7802-1050016	Z7802-1051516
425	Z7802-1048516	Z7802-1049516	Z7802-1050516	Z7802-1052016	Z7802-1050516	Z7802-1051516	Z7802-1052516	Z7802-1054016
450	Z7802-1051016	Z7802-1052016	Z7802-1053016	Z7802-1054516	Z7802-1053016	Z7802-1054016	Z7802-1055016	Z7802-1056516
475	Z7802-1053516	Z7802-1054516	Z7802-1055516	Z7802-1057016	Z7802-1055516	Z7802-1056516	Z7802-1057516	Z7802-1059016
500	Z7802-1056016	Z7802-1057016	Z7802-1058016	Z7802-1059516	Z7802-1058016	Z7802-1059016	Z7802-1060016	Z7802-1061516
550	Z7802-1062016	Z7802-1063016	Z7802-1064016	Z7802-1065516	Z7802-1064016	Z7802-1065016	Z7802-1066016	Z7802-1067516
600	Z7802-1067016	Z7802-1068016	Z7802-1069016	Z7802-1070516	Z7802-1069016	Z7802-1070016	Z7802-1071016	Z7802-1072516

HRDK3H8701 07 Hose pulley block

HRDK3H8701 07 胶管滑轮组(ZM,公制)

序号 No.	零部件代号 Part No.	版本 Edition	名称 Part name		数量 Q'ty	备注 Remark	
1	Z9702-1000016	00	Hose H.P.	高压胶管	2	See table	见表
2	DK3H8-71031R	00	Outer guide steel tube (right)	外导轨钢管(右)	1		
3	Z9702-1000016DSZ	00	Double hose	双联胶管	1	Three piece valve, see table	三片阀,见表
3	Z9702-1000016DSZ	00	Double hose	双联胶管	2	Four piece valve, see table	四片阀,见表
4	B0330-08016-X1	00	Combined bolt	组合螺栓 M8x16	4	Four piece valve	四片阀
4	B0330-08016-X1	00	Combined bolt	组合螺栓 M8x16	2	Three piece valve ,GB5783,GB93	三片阀,GB5783,GB93
5	HRDK3H8711R	02	Guide rail(Outer,right)	外门架导轨总成(右)	1		
6	DK3H8-71011	01	Clip	3T 油缸抱卡	8	Four piece valve ,3t	四片阀,3t
6	DK3H8-71011	01	Clip	3T 油缸抱卡	4	Three piece valve ,3t	三片阀,3t
6	DK3H8-71051	01	Clip	3.5T 油缸抱卡	4	Three piece valve ,3.5,3.8t	三片阀,3.5,3.8t
6	DK3H8-71061	01	Clip	油缸抱卡	8	Four piece valve ,2-2.5t	四片阀,2-2.5t
6	DK3H8-71061	01	Clip	油缸抱卡	4	Three piece valve ,2-2.5t	三片阀,2-2.5t
6	DK3H8-71051	01	Clip	3.5T 油缸抱卡	8	Four piece valve ,3.5,3.8t	四片阀,3.5,3.8t
7	B0330-08020	00	Bolt	螺栓 M8x20	8	Four piece valve	四片阀
7	B0330-08020	00	Bolt	螺栓 M8x20	4	Three piece valve,GB5783-86	三片阀,GB5783-86
8	B4223-00008	00	Nut M8x1	螺母 M8x1	4	Three piece valve ,GB6171-86	三片阀,GB6171-86
8	B4223-00008	00	Nut M8x1	螺母 M8x1	8	Four piece valve	四片阀
9	DK3H8-71041R	01	Inner guide steel tube (right)	内导轨钢管(右)	1		
10	B0330-06016	00	Bolt	螺栓 M6x16	2	Three piece valve,GB5783-86	三片阀,GB5783-86
10	B0330-06016	00	Bolt	螺栓 M6x16	4	Four piece valve	四片阀
11	Z9702-1000016SZ	00	Hose H.P.	高压胶管	1	Three piece valve, see table	三片阀,见表
11	Z9702-1000016SZ	00	Hose H.P.	高压胶管	2	Four piece valve	四片阀
12	HRDK3H8721R	01	Inner gantry guide rail assembly (right)	内门架导轨总成(右)	1		
13	DK3H8-72061	00	Retainer,cover	压板	1	Three piece valve	三片阀
13	DK3H8-72061	00	Retainer,cover	压板	2	Four piece valve	四片阀
14	B0330-08040	00	Bolt M8x40	螺栓 M8x40	4	Three piece valve ,GB5783-86,2,2.5t	三片阀,GB5783-86,2,2.5t

HRDK3H8701 07 Hose pulley block

HRDK3H8701 07 胶管滑轮组(ZM,公制)

序号 No.	零部件代号 Part No.	版本 Edition	名称 Part name		数量 Q'ty	备注 Remark	
14	B0330-08045	00	Bolt	螺栓 M8x45	8	Four piece valve	四片阀
14	B0330-08045	00	Bolt	螺栓 M8x45	4	Three piece valve ,GB5783-86,3-3.8t	三片阀,GB5783-86,3-3.8t
14	B0330-08040	00	Bolt M8x40	螺栓 M8x40	8	Four piece valve	四片阀
15	DK3P8-71021	01	Front cylinder pulley bracket	前缸滑轮支架	1	2,2.5t	2,2.5t
15	DK3J8-71021	01	Front cylinder pulley bracket	前缸滑轮支架	1	3-3.8t	3-3.8t
16	B0330-08020-X1	00	Combined bolt	组合螺栓 M8x20	4	GB5783,GB93	GB5783,GB93
17	DK3P8-72051	02	Pulley	滑轮	5	Three piece valve	三片阀
17	DK3P8-72051	02	Pulley	滑轮	10	Four piece valve	四片阀
18	F26JH-01391	00	Washer	垫圈	10	Four piece valve	四片阀
18	F26JH-01391	00	Washer	垫圈	5	Three piece valve	三片阀
19	B6150-00010	00	Snap ring	挡圈 10	10	Four piece valve	四片阀
19	B6150-00010	00	Snap ring	挡圈 10	5	Three piece valve,GB894.1-86	三片阀,GB894.1-86
20	DK3P8-72111	01	Rubber hose cover	胶管防护盖	2	Four piece valve ,2-2.5t	四片阀,2-2.5t
20	DK3P8-72111	01	Rubber hose cover	胶管防护盖	1	Three piece valve ,2,2.5t	三片阀,2,2.5t
20	DK3J8-72111	00	Rubber hose cover	胶管防护盖	2	Four piece valve ,3-3.8t	四片阀,3-3.8t
20	DK3J8-72111	00	Rubber hose cover	胶管防护盖	1	Three piece valve ,3-3.8t	三片阀,3-3.8t
21	B1210-05012	00	Screw	螺钉 M5x12	4	Four piece valve	四片阀
21	B1210-05012	00	Screw	螺钉 M5x12	2	Three piece valve ,GB818-85	三片阀,GB818-85
22	B5050-00005	00	Washer	垫圈 5	4	Four piece valve	四片阀
22	B5050-00005	00	Washer	垫圈 5	2	Three piece valve,GB93-87	三片阀,GB93-87
23	D16JH-05221A	01	Double row pipe clamp	双列管夹	2	Four piece valve	四片阀
23	D16JH-05221A	01	Double row pipe clamp	双列管夹	1	Three piece valve	三片阀
24	B0330-08030-X1	00	Combined bolt	组合螺栓 M8×30	4	Four piece valve	四片阀
24	B0330-08030-X1	00	Combined bolt	组合螺栓 M8×30	2	Three piece valve ,GB5783,GB93	三片阀,GB5783,GB93
25	DK3P8-75021	00	The guide plate II	导向支板 II	1		
26	B0330-08016-X1	00	Combined bolt	组合螺栓 M8x16	2	Three piece valve ,GB5783,GB93	三片阀,GB5783,GB93
26	B0330-08016-X1	00	Combined bolt	组合螺栓 M8x16	4	Four piece valve	四片阀
27	JT6021-18011LGB	00	Nipple	直通隔板接头	4	Four piece valve	四片阀

HRDK3H8702 00 Rubber hose pulley block (USA)

HRDK3H8702 00 胶管滑轮组 (美制)

序号 No.	零部件代号 Part No.	版本 Edition	名称 Part name		数量 Q'ty	备注 Remark	
1	Z7802-1000016	00	Hose H.P.	高压胶管	2	See table	见表
2	DK3H8-70011	00	Outer guide steel tube (right)	外导轨钢管(右)	1		
3	Z7802-1000016DSZ	00	Resin double hose	树脂双联胶管	1	Three piece valve, see table	三片阀,见表
3	Z7802-1000016DSZ	00	Resin double hose	树脂双联胶管	2	Four piece valve, see table	四片阀,见表
4	B0330-08016-X1	00	Combined bolt	组合螺栓 M8x16	2	Three piece valve ,GB5783,GB93	三片阀,GB5783,GB93
4	B0330-08016-X1	00	Combined bolt	组合螺栓 M8x16	4	Four piece valve	四片阀
5	HRDK3H8711R	02	Guide rail(Outer,right)	外门架导轨总成(右)	1		
6	DK3H8-71011	01	Clip	3T 油缸抱卡	4	Three piece valve ,3t	三片阀,3t
6	DK3H8-71011	01	Clip	3T 油缸抱卡	8	Four piece valve ,3t	四片阀,3t
6	DK3H8-71051	01	Clip	3.5T 油缸抱卡	4	Three piece valve ,3.5,3.8t	三片阀,3.5,3.8t
6	DK3H8-71061	01	Clip	油缸抱卡	4	Three piece valve ,2-2.5t	三片阀,2-2.5t
6	DK3H8-71061	01	Clip	油缸抱卡	8	Four piece valve ,2-2.5t	四片阀,2-2.5t
6	DK3H8-71051	01	Clip	3.5T 油缸抱卡	8	Four piece valve ,3.5,3.8t	四片阀,3.5,3.8t
7	B0330-08020	00	Bolt	螺栓 M8x20	4	Three piece valve,GB5783-86	三片阀,GB5783-86
7	B0330-08020	00	Bolt	螺栓 M8x20	8	Four piece valve	四片阀
8	B4223-00008	00	Nut M8x1	螺母 M8x1	4	Three piece valve ,GB6171-86	三片阀,GB6171-86
8	B4223-00008	00	Nut M8x1	螺母 M8x1	8	Four piece valve	四片阀
9	DK3H8-70021	01	Inner guide steel tube (right)	内导轨钢管(右)	1		
10	B0330-06016	00	Bolt	螺栓 M6x16	2	Three piece valve,GB5783-86	三片阀,GB5783-86
10	B0330-06016	00	Bolt	螺栓 M6x16	4	Four piece valve	四片阀
11	Z7802-1000016SZ	00	Hose H.P.	高压胶管	1	Three piece valve, see table	三片阀,见表
11	Z7802-1000016SZ	00	Hose H.P.	高压胶管	2	Four piece valve	四片阀
12	HRDK3H8721R	01	Inner gantry guide rail assembly (right)	内门架导轨总成(右)	1		
13	DK3H8-72061	00	Retainer,cover	压板	1	Three piece valve	三片阀
13	DK3H8-72061	00	Retainer,cover	压板	2	Four piece valve	四片阀
14	B0330-08040	00	Bolt M8x40	螺栓 M8x40	4	Three piece valve ,GB5783-86,2,2.5t	三片阀,GB5783-86,2,2.5t

HRDK3H8702 00 Rubber hose pulley block (USA)

HRDK3H8702 00 胶管滑轮组 (美制)

序号 No.	零部件代号 Part No.	版本 Edition	名称 Part name		数量 Q'ty	备注 Remark	
14	B0330-08045	00	Bolt	螺栓 M8x45	4	Three piece valve ,GB5783-86,3-3.8t	三片阀,GB5783-86,3-3.8t
14	B0330-08045	00	Bolt	螺栓 M8x45	8	Four piece valve	四片阀
14	B0330-08040	00	Bolt M8x40	螺栓 M8x40	8	Four piece valve	四片阀
15	DK3P8-71021	01	Front cylinder pulley bracket	前缸滑轮支架	1	2,2.5t	2,2.5t
15	DK3J8-71021	01	Front cylinder pulley bracket	前缸滑轮支架	1	3-3.8t	3-3.8t
16	B0330-08020-X1	00	Combined bolt	组合螺栓 M8x20	4	GB5783,GB93	GB5783,GB93
17	DK3P8-72051	02	Pulley	滑轮	5	Three piece valve	三片阀
17	DK3P8-72051	02	Pulley	滑轮	10	Four piece valve	四片阀
18	F26JH-01391	00	Washer	垫圈	5	Three piece valve	三片阀
18	F26JH-01391	00	Washer	垫圈	10	Four piece valve	四片阀
19	B6150-00010	00	Snap ring	挡圈 10	5	Three piece valve,GB894.1-86	三片阀,GB894.1-86
19	B6150-00010	00	Snap ring	挡圈 10	10	Four piece valve	四片阀
20	DK3P8-72111	01	Rubber hose cover	胶管防护盖	1	Three piece valve ,2,2.5t	三片阀,2,2.5t
20	DK3P8-72111	01	Rubber hose cover	胶管防护盖	2	Four piece valve ,2-2.5t	四片阀,2-2.5t
20	DK3J8-72111	00	Rubber hose cover	胶管防护盖	1	Three piece valve ,3-3.8t	三片阀,3-3.8t
20	DK3J8-72111	00	Rubber hose cover	胶管防护盖	2	Four piece valve ,3-3.8t	四片阀,3-3.8t
21	B1210-05012	00	Screw	螺钉 M5x12	2	Three piece valve ,GB818-85	三片阀,GB818-85
21	B1210-05012	00	Screw	螺钉 M5x12	4	Four piece valve	四片阀
22	B5050-00005	00	Washer	垫圈 5	2	Three piece valve,GB93-87	三片阀,GB93-87
22	B5050-00005	00	Washer	垫圈 5	4	Four piece valve	四片阀
23	D16JH-05221A	01	Double row pipe clamp	双列管夹	1	Three piece valve	三片阀
23	D16JH-05221A	01	Double row pipe clamp	双列管夹	2	Four piece valve	四片阀
24	B0330-08030-X1	00	Combined bolt	组合螺栓 M8×30	2	Three piece valve ,GB5783,GB93	三片阀,GB5783,GB93
24	B0330-08030-X1	00	Combined bolt	组合螺栓 M8×30	4	Four piece valve	四片阀
25	DK3P8-75021	00	The guide plate II	导向支板 II	1		
26	B0330-08016-X1	00	Combined bolt	组合螺栓 M8x16	2	Three piece valve ,GB5783,GB93	三片阀,GB5783,GB93
26	B0330-08016-X1	00	Combined bolt	组合螺栓 M8x16	4	Four piece valve	四片阀
27	DK3H8-70031	00	Nipple	直通隔板接头	2	Three piece valve	三片阀

HRDK3P8701 12 Hose pulley block

HRDK3P8701 12 胶管滑轮组

序号 No.	零部件代号 Part No.	版本 Edition	名称 Part name		数量 Q'ty	备注 Remark	
1	DK3P8-71001	01	Pulley bracket I	滑轮支架 I	1		
2	B0330-08020-X	00	Combined bolt	组合螺栓 M8x20	13	Three piece valve,GB5783,GB93	三片阀,GB5783,GB93
2	B0330-08020-X	00	Combined bolt	组合螺栓 M8x20	17	Four piece valve	四片阀
3	B6150-00010	00	Snap ring	挡圈 10	10	Three piece valve,GB894.1-86	三片阀,GB894.1-86
3	B6150-00010	00	Snap ring	挡圈 10	19	Four piece valve	四片阀
4	F26JH-01391	00	Washer	垫圈	19	Four piece valve	四片阀
4	F26JH-01391	00	Washer	垫圈	10	Three piece valve	三片阀
5	DK3P8-72051	02	Pulley	滑轮	10	Three piece valve	三片阀
5	DK3P8-72051	02	Pulley	滑轮	19	Four piece valve	四片阀
6	DK3P8-72061	01	Plate	连接板	1	Four piece valve	四片阀
7	DK3P8-71011	01	Pulley bracket II	滑轮支架 II	1	Four piece valve	四片阀
8	Z9702-1000016SZ	00	Hose H.P.	高压胶管	2	See table	见表
9	Z9702-1000016SZ	00	Hose H.P.	高压胶管	2	Four piece valve, see table	四片阀,见表
10	DK3P8-72011	00	The pipe clamp plate	管夹支板	1		
11	DK3P8-72001A	00	Pipe clamp	管夹	1		
12	B8030-08025	00	Screw M8x25	螺钉 M8x25	2	GB70-85	GB70-85
13	B5050-00008	00	Washer	垫圈 8	6	Three piece valve,GB93-87	三片阀,GB93-87
13	B5050-00008	00	Washer	垫圈 8	12	Four piece valve	四片阀
14	D16JH-05221A	01	Double row pipe clamp	双列管夹	5	Four piece valve	四片阀
14	D16JH-05221A	01	Double row pipe clamp	双列管夹	2	Three piece valve	三片阀
15	B0330-08030	00	Bolt	螺栓 M8x30	8	Four piece valve	四片阀
15	B0330-08030	00	Bolt	螺栓 M8x30	2	Three piece valve,GB5783-86	三片阀,GB5783-86
16	DK3P8-72121	01	The guide plate I	导向支板 I	1		
17	DK3P8-72171	00	Four-way steel pipe assembly	四通钢管总成	1		
18	DK3P8-72181	00	Four-way elbow assembly	四通弯管总成	1	Four piece valve	四片阀
19	DK3P8-72111	01	Rubber hose cover	胶管防护盖	2	2,2.5t	2,2.5t
19	DK3J8-72111	00	Rubber hose cover	胶管防护盖	2	3,3.5t	3,3.5t
20	B1210-05012	00	Screw	螺钉 M5x12	4	GB818-85	GB818-85
21	B5050-00005	00	Washer	垫圈 5	4	GB93-87	GB93-87

HRDK3P8702 03 Rubber hose pulley block (SAE)

HRDK3P8702 03 胶管滑轮组(美制)

序号 No.	零部件代号 Part No.	版本 Edition	名称 Part name		数量 Q'ty	备注 Remark	
1	DK3P8-71001	01	Pulley bracket I	滑轮支架 I	1		
2	B0330-08020-X	00	Combined bolt	组合螺栓 M8x20	13	Three piece valve,GB5783,GB93	三片阀,GB5783,GB93
2	B0330-08020-X	00	Combined bolt	组合螺栓 M8x20	17	Four piece valve	四片阀
3	B6150-00010	00	Snap ring	挡圈 10	19	Four piece valve	四片阀
3	B6150-00010	00	Snap ring	挡圈 10	10	Three piece valve,GB894.1-86	三片阀,GB894.1-86
4	F26JH-01391	00	Washer	垫圈	19	Four piece valve	四片阀
4	F26JH-01391	00	Washer	垫圈	10	Three piece valve	三片阀
5	DK3P8-72051	02	Pulley	滑轮	19	Four piece valve	四片阀
5	DK3P8-72051	02	Pulley	滑轮	10	Three piece valve	三片阀
6	DK3P8-72061	01	Plate	连接板	1	Four piece valve	四片阀
7	DK3P8-71011	01	Pulley bracket II	滑轮支架 II	1	Four piece valve	四片阀
8	Z7802-1000016SZ	00	Hose H.P.	高压胶管	2	See table	见表
9	Z7802-1000016SZ	00	Hose H.P.	高压胶管	2	Four piece valve, see table	四片阀,见表
10	DK3P8-72011	00	The pipe clamp plate	管夹支板	1		
11	DK3P8-72001	01	Pipe clamp	管夹	1		
12	B8030-08025	00	Screw M8x25	螺钉 M8x25	2	GB70-85	GB70-85
13	B5050-00008	00	Washer	垫圈 8	6	Three piece valve,GB93-87	三片阀,GB93-87
13	B5050-00008	00	Washer	垫圈 8	12	Four piece valve	四片阀
14	D16JH-05221A	01	Double row pipe clamp	双列管夹	2	Three piece valve	三片阀
14	D16JH-05221A	01	Double row pipe clamp	双列管夹	5	Four piece valve	四片阀
15	B0330-08030	00	Bolt	螺栓 M8x30	2	Three piece valve,GB5783-86	三片阀,GB5783-86
15	B0330-08030	00	Bolt	螺栓 M8x30	8	Four piece valve	四片阀
16	DK3P8-72121	01	The guide plate I	导向支板 I	1		
17	DK3P8-70011	00	Four-way steel pipe assembly	四通钢管总成	1		
18	DK3P8-70021	00	Four-way elbow assembly	四通弯管总成	1	Four piece valve	四片阀
19	DK3J8-72111	00	Rubber hose cover	胶管防护盖	2	3,3.5t	3,3.5t
19	DK3P8-72111	01	Rubber hose cover	胶管防护盖	2	2,2.5t	2,2.5t
20	B1210-05012	00	Screw	螺钉 M5x12	4	GB818-85	GB818-85
21	B5050-00005	00	Washer	垫圈 5	4	GB93-87	GB93-87

EKKO[®]

MATERIAL HANDLING EQUIPMENT

MOVING AHEAD

EKKO Material Handling Equipment Mfg., Inc.
1761 W Holt Ave
Pomona, CA 91768
(877)232-6517
Info@ekkolifts.com
Support@ekkolifts.com
www.EKKOlifts.com