



Operations & Maintenance Manual

Lithium Walkie Stacker

EB20CS-177LI/189LI/216LI



Instructions for use

Please read this manual carefully and operate the vehicle safely.

- Do not operate this vehicle without training.
- Please comply with ISO3691 “Safety Specification for Motor Vehicles Industry”.
- Please do not modify or change the repair parameters, including adjusting the pressure. Any loss or damage to the vehicle resulting from such actions will be your responsibility, and doing so will void our warranty commitment.

SPECIAL WARNING:

The company is committed to innovation and sustainable development. As part of this commitment, we continually improve the technology of our products. Therefore, we reserve the right to make changes and improvements to any product described in this specification without prior notice.

1. Overview

Full electric stacker (hereinafter referred to as stacker).

Electric stacker powered by battery, it is suitable for narrow aisles and limited space in operations, is an ideal tool for storage and logistics industries.

1.1 Main parts and components

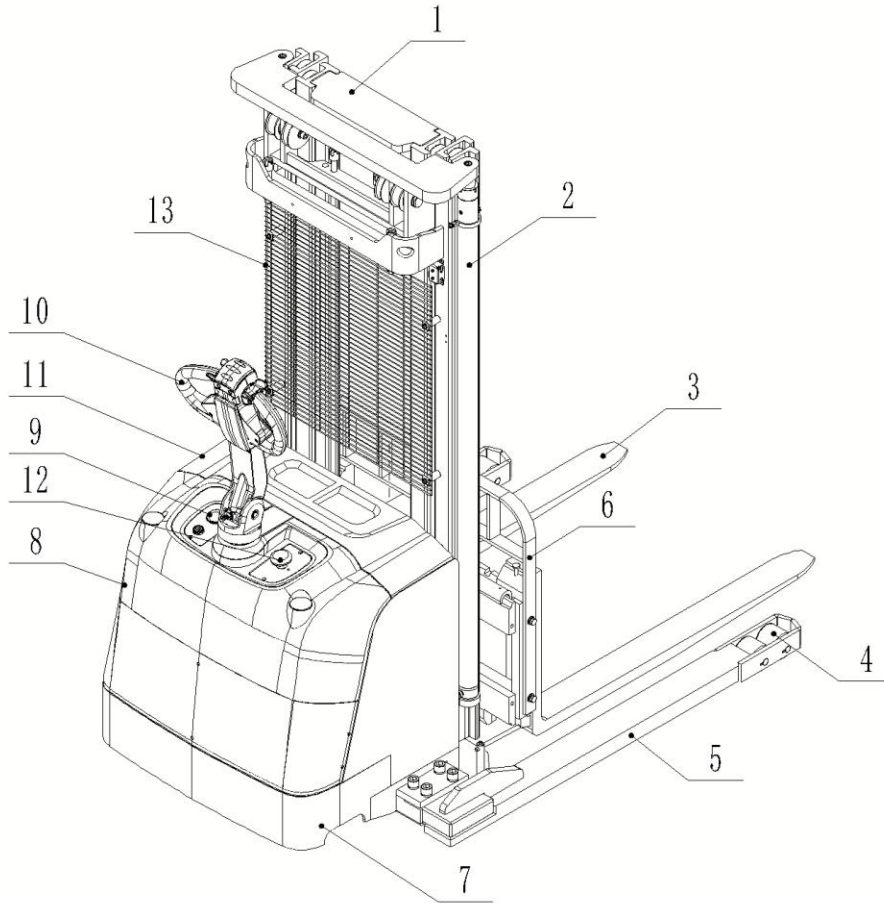

No.	name	No.	name	No.	name
1	Mast	5	Outrigger	9	Ammeter
2	Cylinder	6	Backstop	10	Operating handle
3	Fork	7	Frame	11	Battery cap
4	Fork wheel	8	Cover	12	Scram switch

1.2 Permissible use conditions

◇The stacker is intended to be used for loading and unloading trucks, loading docks, stock rooms, manufacturing floors and warehousing and other specific areas.

- ◇ Can only be used on flat surfaces with sufficient carrying capacity.
- ◇ Can only be used on driving roads with unobstructed view and as permitted by the equipment user.
- ◇ Is used within the specified rated load.
- ◇ The average ambient temperature under continuous operation conditions is + 77°F.
- ◇ The maximum ambient temperature for the stacker in the short term (1h) is + 104°F.
- ◇ The minimum ambient temperature for the stacker under normal indoor conditions is + 41°F.
- ◇ The minimum ambient temperature for using the stacker under normal outdoor conditions is - 4°F.
- ◇ The elevation is 6,560 feet.
- ◇ The maximum climb at full load is 6%.
- ◇ It is not designed to travel sideways or obliquely while traveling uphill. When transporting freight uphill, keep the forks facing forward; when moving cargo downhill, keep the forks pointing uphill.

1.3 Obligations and responsibilities of the equipment user

In this operating instruction, "Equipment User" means any person who directly uses or appoints to entrust others to use the stacker. In circumstances such as lease, sale, lease, the "equipment user" represents the party undertaking the stipulated operation obligations according to the terms of the contract concluded between the equipment owner and the user.

The user of the equipment must ensure that the stacker is used only for the specified purposes and promptly eliminate all hazards that may endanger the life and health of the user or a third party. In addition, the equipment user must also strictly abide by the accident prevention regulations, other safety and technical regulations, and the operation, maintenance, and repair standards of the equipment. The equipment user must ensure that all operators carefully read and understand the contents of these operating instructions.

△ Failure to comply with these operating instructions will automatically void the company's warranty. If customers and/or third parties perform non-standard operations on the equipment without permission from the company's customer service department, the company will not be responsible for the resulting losses.

1.4 Install fittings or modify the stacker

Installation of accessories: If you need to install or add additional devices that affect or supplement the functions of the stacker, you must obtain written consent in advance. Depending on the actual situation, it may also be approved by the local competent authority.

The review results of the competent authorities do not represent the opinions of the company.

2. Main Technical Parameters and Characteristics

2.1 Schematic diagram

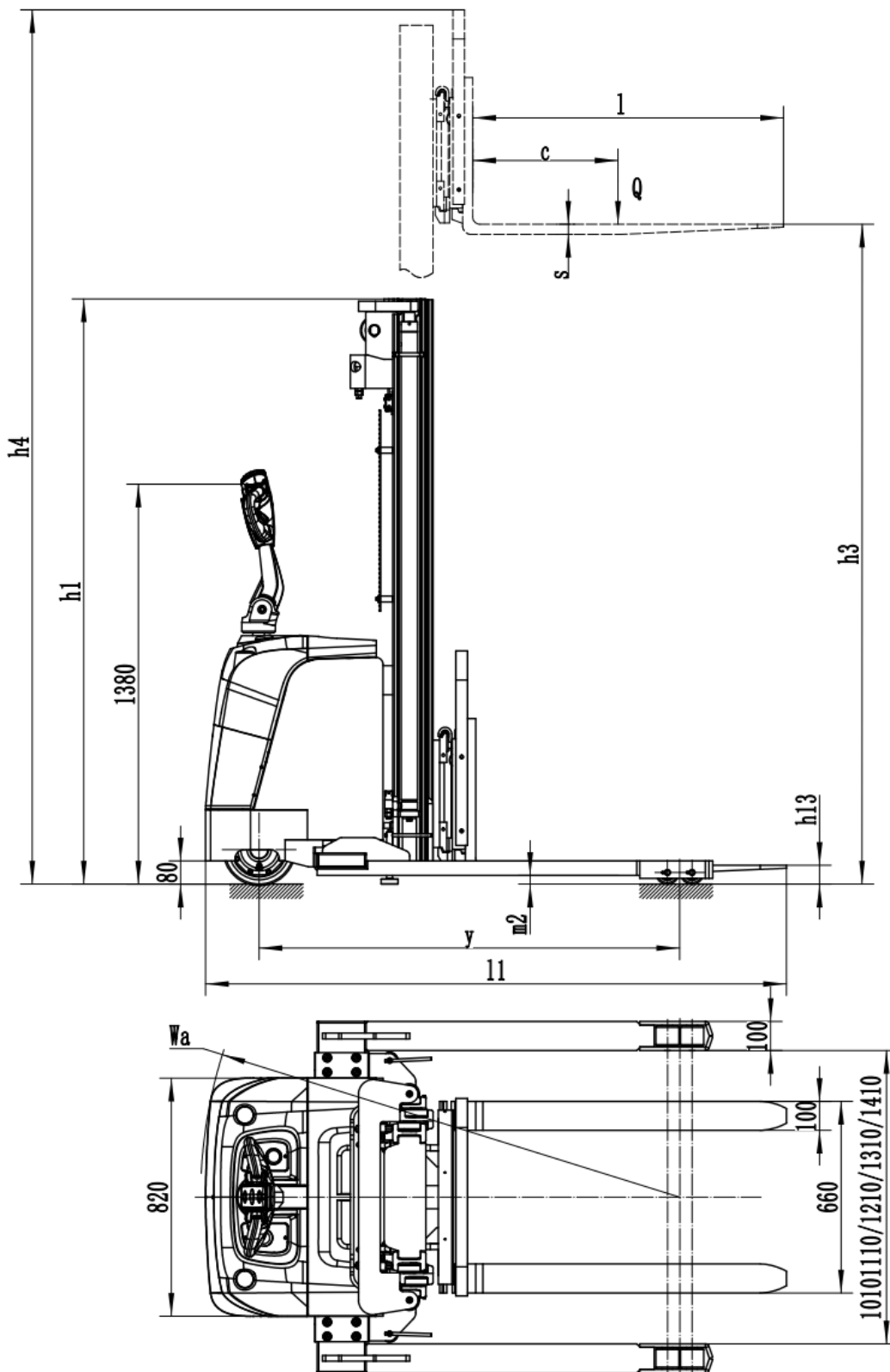

2.2 Technical data of standard specifications

Feature	1.1	Model		EB20CS-177/189/216LI
	1.2	Drive method		Electric power
	1.3	Driving mode		Stand
	1.4	Capacity	Q(lbs.)	4,400
	1.5	Load center distance	c(in)	20
Wheel	3.1	Wheel material		Polyamine wheel
Size	4.1	Lifting height	h3(in)	177/189/216
	4.2	Lowered mast height	h1(in)	79.33/83.26/92.71
	4.3	Maximum mast height	h4(in)	206.3/218.1/245.6
	4.2	Lowered fork height	h13(in)	2.55
	4.3	Overall length	l1(in)	81.88
	4.4	Inside width of legs	in	39.8/43.7/47.7/51.6/55.6
	4.5	Fork size	S/E/L(in)	2.36/5.6/45.27
	4.6	Outside fork width	b5(in)	8.7 ~ 32.1
	4.7	Minimum ground clearance	m2(in)	1.2
	4.8	Turning radius	Wa(in)	65
Function	5.1	Driving speed, laden/ unladen	Km/h	3.5/4
	5.2	Lift speed, laden / unladen	in/s	2.9/3.6
	5.3	Drop speed, laden / unladen	in/s	3.35/2.75
	5.4	Climbing capability, laden / unladen	%	3/10
	5.5	Driving brake	Electric motor	Electromagnetic
Motor	6.1	Drive motor power	kW	1.5
	6.2	Increase motor power	kW	3
	6.3	Battery voltage/rated capacity	V/Ah	Lithium battery 24/150
Lead acid 24/210				
Other	7.1	Noise level at the driver's ear meets DIN12053	dB(A)	<70

* The above technical data is all standard data, and our company reserves the right to make technical changes and supplements.

3. Hoisting, fixing and Transportation of stackers.

The stacker is not appropriate for long-distance transportation, as it is designed for short-distance handling and loading and unloading at the factory site. The stacker truck can be safeguarded during long-distance transportation by transporting on vehicles, trailers, and other long-distance transport stackers via the cargo loading and unloading platform of the lifting device.

3.1 Lift

- ◇Use professional cranes and lifting equipment
- ◇Do not stand below the stacker
- ◇When lifting or putting down, keep the stacker stable and slow to avoid bumps or safety accidents.

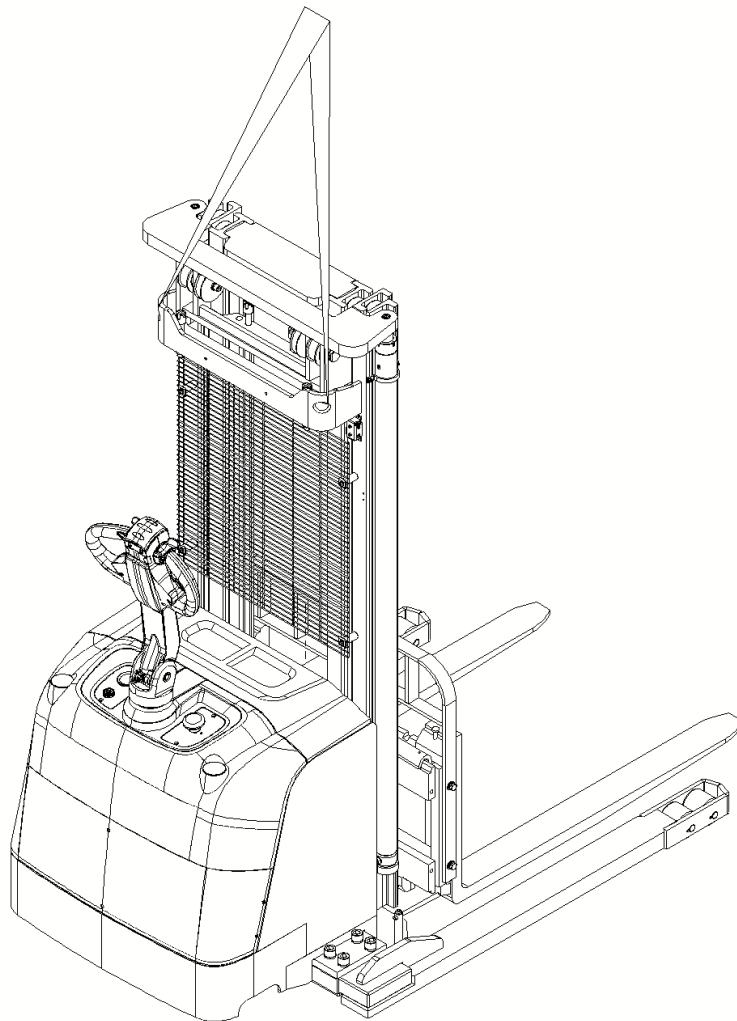

3.2 Fixed position during transportation

Lower the fork and park the stacker safely.

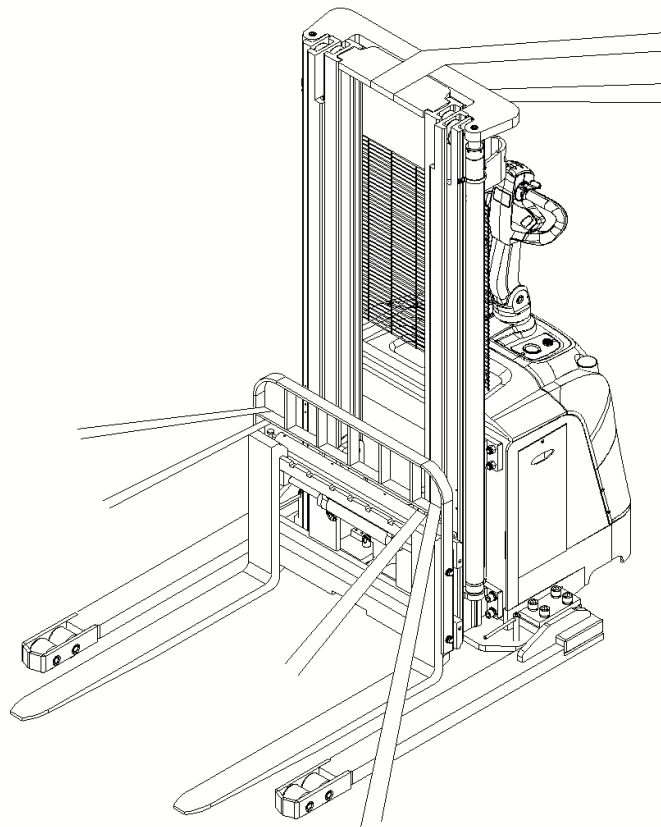

3.3 Transportation

The stacker as a short distance stacking handling tool in the field (factory), is not suitable for long-distance driving. To transport a stacking truck over a distance, it needs to attach it firmly to the truck or truck.

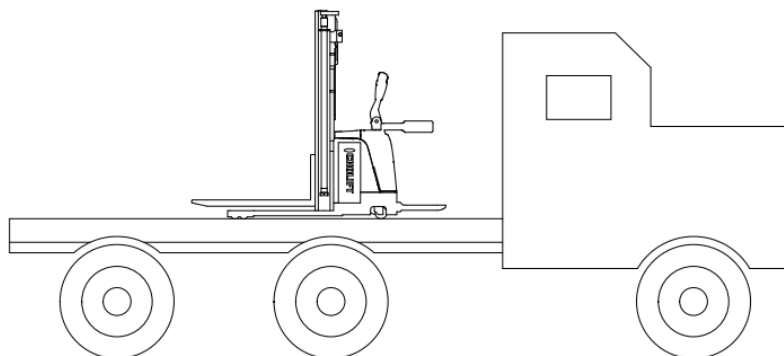

4. The Operation of the Stacker Truck

The stacker must be operated and maintained according to the instructions specified in this manual. The correct use and operation of the stacker will bring great convenience to your work. The use of the stacker for any other use is a non-conforming operation and may cause casualties or damage to a stacker truck or other property.

4.1 Check before the operation

◆ Leak check

On the ground where the stacker is parked, check for hydraulic oil and other leaks.

◆ Cargo fork check

Check whether the cargo fork is cracked and bent.

◆ Wheel check

Check the wheel for cracking, damage, or abnormal wear. Check for loose wheel fasteners. Check for ropes around the wheel.

◆ Door frame inspection

Check whether the gantry is deformed and whether the chain is loose.

◆ Hydraulic Oil Inspection

Open the rear cover and check whether the oil level is between the specified ranges and added when insufficient.

◆ Battery check

Check that the battery is held firmly and secure.

Check both terminal wiring for loose and or damaged wires.

4.2 Start

◆ Meter check

Open the key switch and emergency stop button and check whether the instrument power display is normal.

◆ Lift check

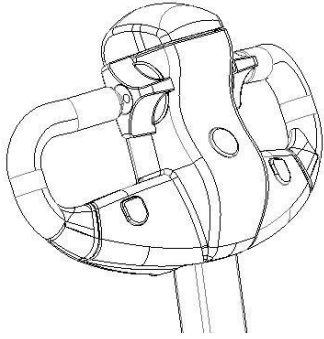

Press the lift button to check the forks lift. Press the drop button to check the fork drop. Check the lifting system for abnormal sound.

◆ Forward and backward check

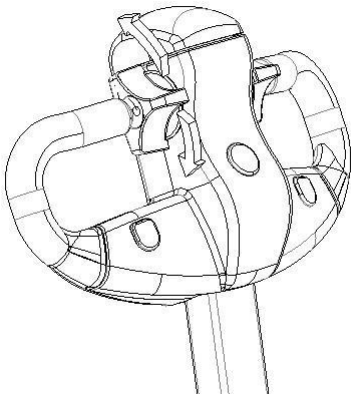

Press the operating handle to the driving state, use your thumb to turn the throttle toward the fuselage, and observe the stacker's retreat; otherwise, observe the forward direction of the stacker.

◆ Turned to check

While the stacker is driving, turn the operating handle to the left or right to see if the steering is normal.

◆ Horn check

Press the horn and check the sound.

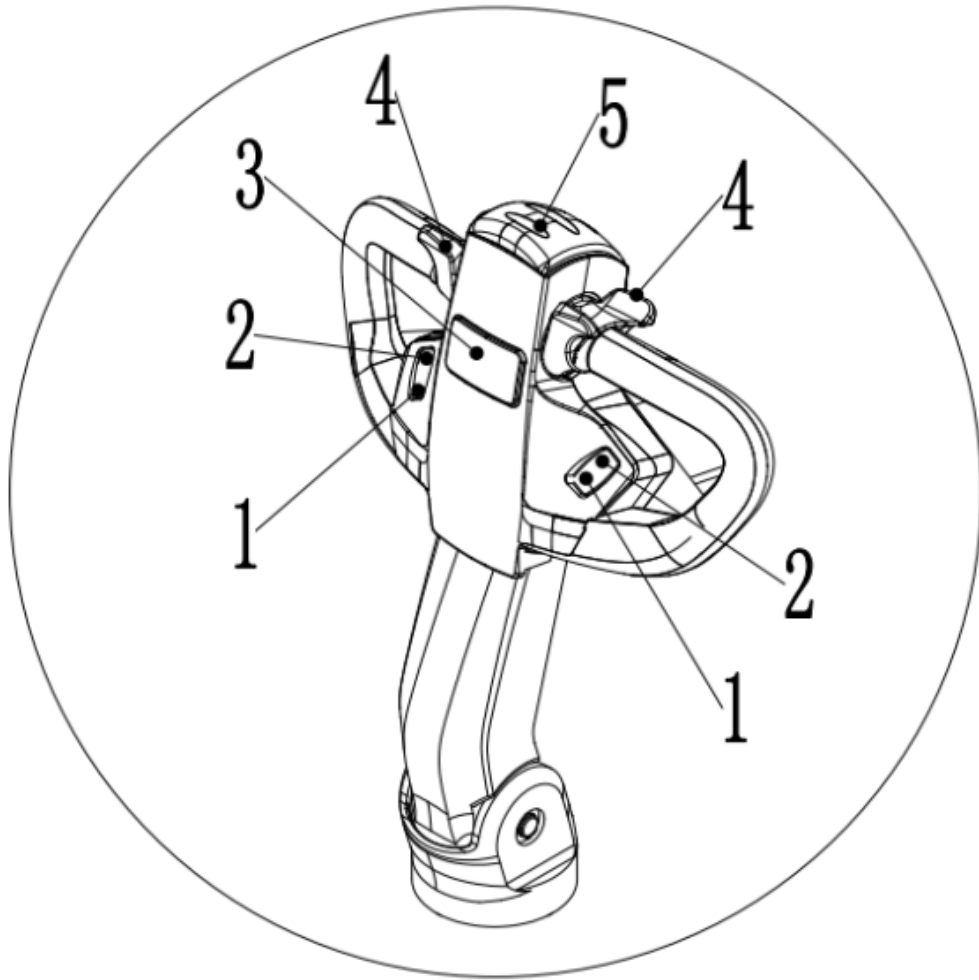

No.	name	function
1	Lift down button	Press the drop button and the fork drops
2	Lift up button	Press the rise button and the fork rises
3	Horn button	Press the horn button to make a beep sound
4	Forward and backward accelerator	Turn the stacker back to the body, otherwise the stacker forward
5	Emergency reverse button	Touch the button, the stacker emergency reverse backward

4.3 Parking

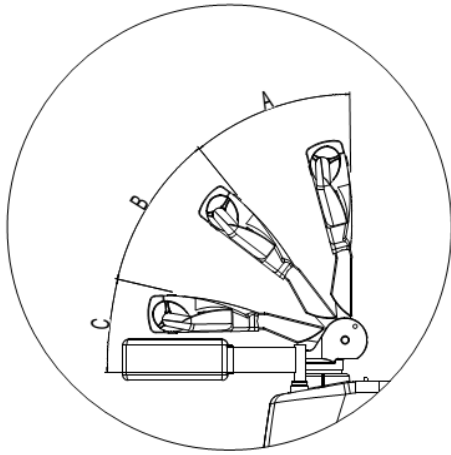

The handle is divided into A, B and C in the vertical surface, and A and C are the braking area.

The rudder handle is in zone A or C, and the stacker is braking.

The handle is in area B, and the stacker is in normal driving condition.

 Hazard: No stacker stays on the slope.

◆ Acceleration with deceleration

The accelerator has the function of infinite speed regulation, and the rotation range of the accelerator determines the speed of driving.

◆ Lift up and down

When you rotate clockwise or counterclockwise, it will determine the stacker forward and backward.

◆ Emergency out-off



For stacker emergencies, press the emergency stop button immediately.

5. Maintenance

This chapter describes the maintenance work required to ensure the safe and efficient operation of the stacker truck. To make your stacker last longer, we recommend that you regularly check and maintain your stacker, and regularly check unit if your stacker is stopped or not in use for a long time.

Stacker lubrication is the key link of maintenance work, poor lubrication will reduce the mechanical efficiency and cause the rapid wear of parts, affect the normal operation of the stacker truck, so we must often do a good check of lubrication work. Stacker maintenance is also the focus of the maintenance work, according to the provisions of the stacker daily maintenance work can be avoided.

⚠ Warning: Before maintenance, ensure the battery plug is disconnected and hang a warning sign on the stacker.

5.1 Daily maintenance table

Battery

Inspection item	Maintenance requirements	Daily (8h)	Weekly (50h)	Monthly (200h)	Every 3 months (600h)	Semiannually (1200h)
Battery	Check the acid concentration, liquid level, and battery voltage		•			
	Check if the power supply is too low	•				
	Check whether the terminal post is fixed, and whether the cable line is loose			•		
	Clean foreign matter on the surface promptly	•				
	Whether the battery cable is damaged?			•		

Controller

Inspection item	Maintenance requirements	Daily (8h)	Weekly (50h)	Monthly (200h)	Every 3 months (600h)	Semiannually (1200h)
Controller	Whether the plug is aging					•
	Is the contactor normal			•		
	Check for the proper connection between the motor — battery — drives			•		

Lifting system

Inspection item	Maintenance requirements	Daily (8h)	Weekly (50h)	Monthly (200h)	Every 3 months (600h)	Semiannually (1200h)
Chain and Turbine	Check the chain for rust					•
	Check that the chain is loose			•		
	Check the chain for deformation and damage					•
Lift cylinder	Check the piston rod for loosening, deformation, and damage					•
	Check that the cylinder is working properly	•				
	Check for any leakage		•			
	Check positioning pins and cylinder block for wear and damage			•		
Fork	Check the fork for deformation, wear, and damage				•	
	Check the fork body and upper slide for wear and cracks due to welding defects				•	
Frame and fork carrier	Check for welding defects, cracks, and damage between the inclined cylinder support and the frame			•		

	Check the fixation of the lifting mast					
	Visual inspection of the rollers	•				
	Check the fixing of the lifting gantry	•				
	Check parallelism and side clearance			•		

Motor

Inspection item	Maintenance requirements	Daily (8h)	Weekly (50h)	Monthly (200h)	Every 3 months (600h)	Semiannually (1200h)
Motor	Check the wear of the carbon brush					•
	Check the motor fixation			•		

Driving system

Inspection item	Maintenance requirements	Daily (8h)	Weekly (50h)	Monthly (200h)	Every 3 months (600h)	Semiannually (1200h)
Quick checks	Check for abnormal noise	•				
	Check for oil leakage		•			
	Replace gear oil					•

Wheel

Inspection item	Maintenance requirements	Daily (8h)	Weekly (50h)	Monthly (200h)	Every 3 months (600h)	Semiannually (1200h)
Drive wheel, balance wheel and bearing wheel	Check for wear and damage	•				
	Check support and fixation		•			
	Check for foreign objects on the tire	•				

Brake system

Inspection item	Maintenance requirements	Daily (8h)	Weekly (50h)	Monthly (200h)	Every 3 months (600h)	Semiannually (1200h)
Microswitch	Check the brake state of the control handle in the horizontal and vertical position	•				
	Whether the micro dynamic switch function is normal			•		
Brake	Whether the installation is firm			•		
	Whether damaged				•	
	Clean the brake				•	
	Is the brake sensitive	•				

Hydraulic assembly

Inspection item	Maintenance requirements	Daily (8h)	Weekly (50h)	Monthly (200h)	Every 3 months (600h)	Semiannually (1200h)
Hydraulic oil tank	Check the hydraulic oil level and replace the hydraulic oil					•
	Clean the oil suction filter			•		
	Clean the outside			•		
Hydraulic pump	Check the hydraulic pump for leaks		•			
	Check the hydraulic pump for damage				•	

Handle system

Inspection item	Maintenance requirements	Daily (8h)	Weekly (50h)	Monthly (200h)	Every 3 months (600h)	Semiannually (1200h)
Circuit emergency stop switch	stipulate	•				
Up and down button	stipulate	•				
Horn	Check that the horn is normal	•				
Appearance	Check that the instrument display is normal	•				

Attached table.

Replace key parts regularly.

Some parts must be inspected regularly for damage; to further improve the safety of the product, users should regularly replace the parts in the table below.

If these parts are damaged before replacement, they should be replaced immediately.

Key Safety Parts Description	Use time interval (years)
Lifting system hydraulic tubing	1-2
Rising chain	2-4
High-pressure line of the hydraulic system	2
Internal sealant, rubber products	2
Hard wire	1

6. Troubleshooting and Handling

6.1 Fault alarm and handling

When the stacker truck fails, the electronic control indicator light will display the alarm failure.

6.2 Common faults and treatment methods

No.	Fault description	Fault cause	Solution
1	Stacker not moving (contactor not working)	①The control circuit fuse is burnt out	Renewal
		②The power switch is in bad contact or damaged	Repair or replace
		③Main circuit fuse blown	Renewal
		④The electrical lock switch is in bad contact or damaged	Repair or replace
		⑤The battery connection is loose or detached	Reattach
	Stacker not moving (contactor working)	①The driving wheel is not engaged near the magnetic brake, and the stacker is in braking state	Repair or replace
		②Walking motor carbon brush wear or poor contact with carbon brush	Repair or replace
		③The excitation coil of the walking motor is broken or the wire end is in poor contact.	Repair or replace

		④The contactor contacts have poor contact	Repair or replace
		⑤The MOSFET tube-type circuit board is faulty	Repair or replace
2	Stacker trucks can only advance (or step back)	① The contactor is poorly touched or burnt out	Repair or replace
		②The circuit board is faulty	Repair or replace
3	Stacker cannot stop while driving	The contactor contact is damaged, and the moving contact is not reset	Emergency power off and replace contactor contacts
4	Brake failure	①The micro dynamic switch mounting bolts are loose or damaged	Adjust or tighten the bolts, or replace the microswitch
		②Alter magnetic brake wiring is loose or damaged	Tighten the bolts or repair the underside magnetic brake
		③Near-magnetic brake pad wear	Replace the brake pad
5	Turning gets stuck	①The steering gear bearing is damaged	Replace the bearing
		②Steering gear bearings are short of oil or excessive dust	Clean the bearings
6	The drive wheel steering is heavy and noisy, and the motor is overloaded	The ① gear and bearing have a foreign body stuck	Clean or change bearings
		②Bearing installation clearance, or the ring is off	Clap falls off, reinstall, adjust the clearance
		③The front wheel bearing is damaged	Replace the bearing
7	The fork does not rise	①Overloaded use	Reduce the load
		②The overflow valve pressure is too low	Vertical steering
		③The lifting cylinder has abnormal internal leakage	Replace seals
		④The hydraulic oil is not enough	Add a proper amount of filtered hydraulic oil
		⑤The battery voltage is insufficient	Battery charging
		⑥The handle is not in the horizontal or vertical position, and the oil pump motor is not energized	Maloperation
		⑦The oil pump motor is damaged	Repair or replace
		⑧ Oil pump damaged	Repair or replace
		⑨The rise button switch is damaged	Repair or replace
		⑩The electrical lock is not open or damaged	Repair or replace
⑪The battery voltage is severely insufficient	Charge		
8	The fork does not fall after rising	①Overload and deformation of the internal gantry	Repair or replace
		② overload and deformation of external gantry	Repair or replace
		③The gantry roller is stuck	Repair or adjust
		④The gantry guide rod is bent	Repair or straighten

		⑤ The return oil hole is blocked	Put in order
		⑥ The hydraulic station solenoid valve is out of control	Troubleshoot the solenoid valve
9	Battery end voltage reduction (after charging)	① The individual single-circuit battery is damaged	Repair or replace
		② The battery has a low liquid level	Add electrolyte
		③ Impurities are present in the electrolyte	Change the electrolyte

If you fail to troubleshoot after performing all the steps listed in the Solution, contact our customer Service. Further search and troubleshooting operations must be conducted by specially trained after-sales service personnel.

7. Safety Operation Procedures for Stacker Truck

 **Warning:** To ensure the safe operation of stacker trucks, the operators should be familiar with the working principle and relevant regulations of stacker trucks, and should follow the following procedures:

- 1) Only over 18 years old, professionally trained, and certified operators are allowed to operate the stacker.
- 2) The operator must be familiar with the use instructions of the stacker, wear helmets, work shoes, work clothes and other protective equipment.
- 3) The operator uses the stacker to check whether the safety device is complete and intact, and all the parts are sensitive and effective. The stacker is prohibited to be operated by anyone "under the influence":
- 4) The working road surface shall be flat with cement or similar ground. Precheck the ground conditions of the work site. Organize the workplace, remove obstacles, remove gravel, sediment, wipe away oil, water traces.
- 5) Before operation, first familiarize yourself with the curve diagram on the load curve sign, which represents the relationship between the rated load and the load center distance. Overloading is strictly prohibited.
- 6) Before starting, ring the horn to make sure that no one is around.

- 7) When stacking the goods, do not allow goods to deviate from the center of the fork, and when the goods can easily fall away from the center of the fork, when turning or driving on uneven pavement. This increases the possibility of a rollover.
- 8) Quick drive, sharp stop, sharp turn operation is not allowed.
- 9) Do not operate unit with forks raised.
- 10) The cargo should be guided or allowed to run later when it is overloaded and impacts the line of sight.
- 11) Due to the small wheels of the pallet stacker, the truck cannot run on the road, and only operates on smooth and level surfaces.
- 12) It is strictly prohibited to stand or walk under the forks during operation. Do not stand on the forks. Make sure your head, hands, feet, and body are not stretched over the forks and front legs. Once caught, life is in danger. Do not put your hands between the inner and outer gantry.
- 13) Loading uphill can cause cargo to run ahead. Do not turn on the ramp. Otherwise, there is a danger of tipping over. Avoid working on a ramp.
- 14) Do not let the battery drain until the stacker can no longer be moved before recharging it, as this will shorten the battery life. When the power indicator light flashes red, please charge immediately.
- 15) Check the electrolyte liquid level once a week. When the electrolyte liquid level is low, supplement the distilled water to the specified liquid level height. The electrolyte was 15-20mm higher than the protective sheet.
- 16) The acid in the battery is corrosive. When operating the battery, wear good labor protection clothing and wear protective goggles.
- 17) The stacker uses electromagnetic braking. After the power is cut off, the brake stops, and the stacker cannot be pulled (towed).
- 18) Please comply with the requirements of the operation and maintenance manual and vehicle markings. Check signs and replace any that are damaged or fallen off.
- 19) The workplace should be equipped with fire extinguishers. Users can also choose to equip the vehicle with a fire extinguisher. Drivers and managers should be familiar with the location and use of fire extinguishers.

- 20) It is prohibited to clean the inside of the stacker with water, and the stacker is not allowed to be placed in the open on rainy days.
- 21) The battery power plug must be unplugged before any disassembly or repair is performed on the stacker.
- 22) Whenever a malfunction occurs, the stacker must stop, hang a "failure" sign on the vehicle, remove the key, and report to the manager. The stacker can only be used after troubleshooting. If a sudden failure occurs when lifting goods, going uphill, or downhill, personnel should be organized immediately to repair it.
- 23) When any flame comes close to the battery, explosive gases will be produced inside the battery.
- 24) Before charging, check for obvious damage to the cable connection and plug connection parts.
- 25) The space where the stacker is charged should be adequately ventilated.
- 26) When the forklift is not in use, the battery must be charged and stored. It is recommended to charge once a week.
- 27) No flammable and sparking equipment should be located within at least 7 feet of the stacker.
- 29) Never place metal items on the battery to avoid sparks or short circuiting.
- 30) If the battery life exceeds 4 years, it should be replaced.
- 31) Try not to use it under overload, high humidity or high slope.
- 32) When charging externally, do not connect the battery polarity, otherwise the battery may be scrapped.
- 33) After the battery is scrapped, please return it to the recycling bin for unified disposal and do not discard it randomly.

8. Schematics

8.1 Electrical system

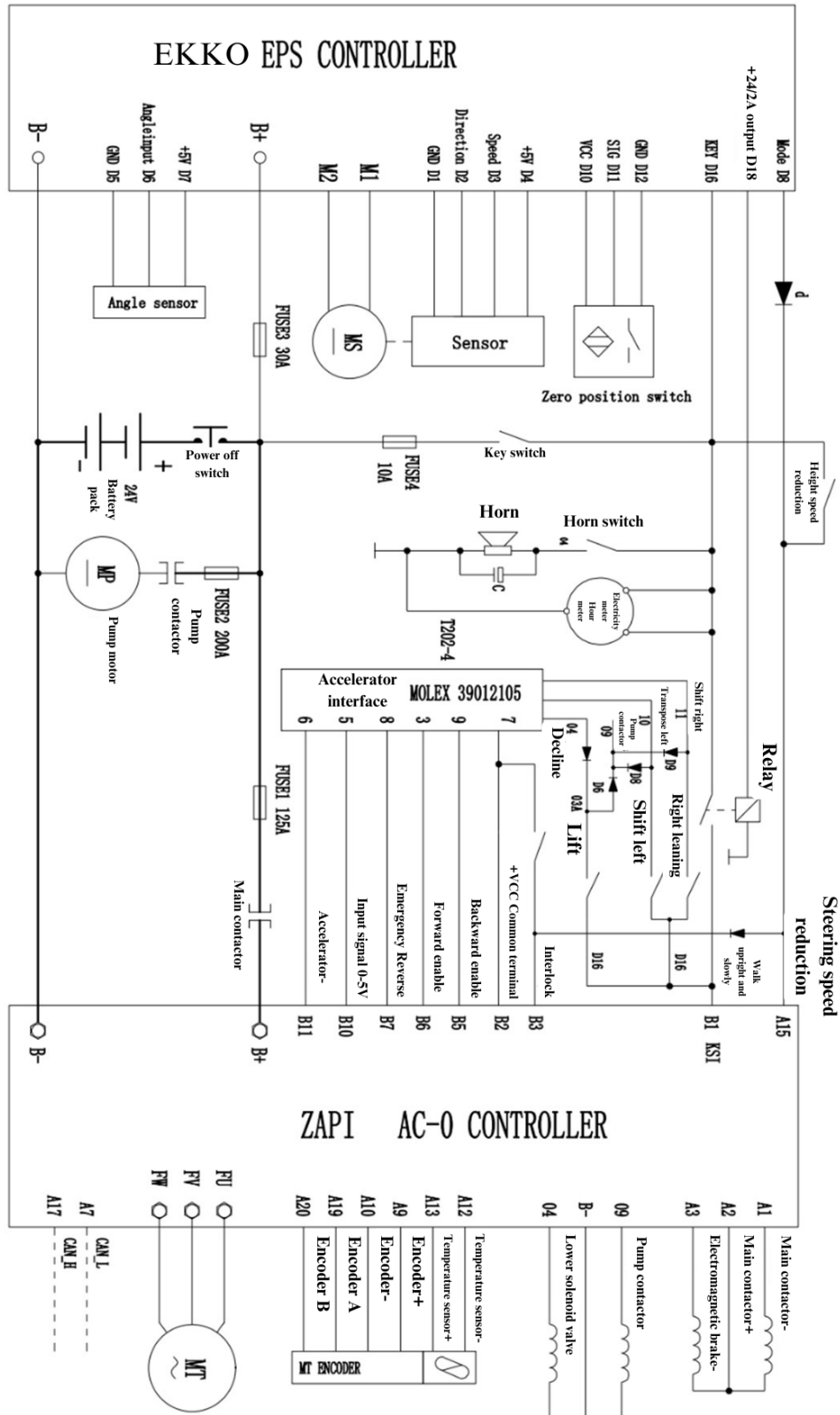

8.2 Hydraulic system

