

EKKO[®]

MATERIAL HANDLING EQUIPMENT

MOVING **AHEAD**

STAND-UP LITHIUM RIDER REACH TRUCK EK18RR-196Li SERIES

- Load Capacity 4000 lbs.
- Lift Height 196 in. 3 Stage
- Side Shift
- 48V/350Ah Lithium Battery
- Free Lift 53.15"
- Hydraulic Power Steering
- Length 102.28"
- Curtis Controller
- Tilt 3/6 degree
- Mast Height 96.42"
- Battery & Charger
- 3 Year Limited Warranty



www.ekkolifts.com

EK18RR-196Li

Superior quality, maneuverable, compact, and durable for all your material handling applications. Ideal for small aisles and areas.

WEIGHT CAPACITY: 4000 lbs. @ 24" load center

LIFT HEIGHT: 196

SIDE SHIFT

MAST HEIGHT: 96.42"

TURNING RADIUS: 75"

FREE LIFT: 53.15"

TILT: 3/6 degree

INDUSTRIAL BATTERY / CHARGER: 48V 350Ah, Lithium battery with external direct connect Charger, input: three phase 440V, Output: 48VDC/200A

BRAKING: Electromagnetic

SPEED TRAVEL: 5.9 mph empty ; 5.59 mph loaded

LIFTING SPEED: 9.05" ips empty; 7.48" ips loaded

LOWERING SPEED: 11.81" ips empty; 9.05" ips loaded

FRONT WHEELS: Polyurethane

REAR WHEELS: Polyurethane

HYDRAULICS LIFTING MOTOR: 48V 11000 Watt lifting motor with hardened chrome moly steel for durability.

DRIVE MOTOR: 48V 6000-Watt ZF AC drive motor for efficiency and high torque.

AC CONTROLLER: 48V Curtis provides performance through entire range of speed; Constant travel speed regardless of load; Battery discharge indicator combination gauge.

BRAKES: Drum Brakes with Electro-magnetic braking for secure stopping power

LIGHTING: LED Head lights, turn signals and brake lights.

OPERATOR CONTROLS: Tilt, lifting, lowering, side shifting forks, horn functions are located in the ergonomic Operators Compartment; Led lighting.

CHASSIS AND MAST: Robotic Welding; Heavy duty steel chassis with I-beam mast for durability; Telescoping mast.



LITHIUM RIDER REACH

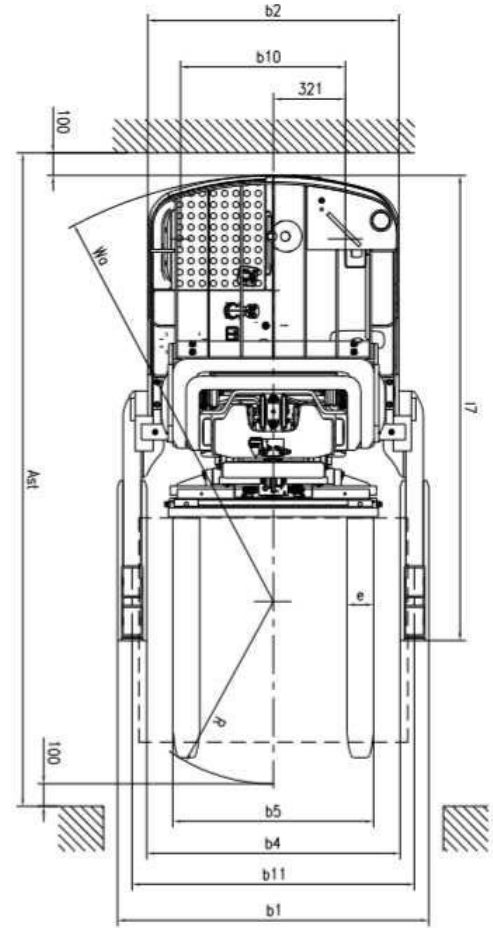
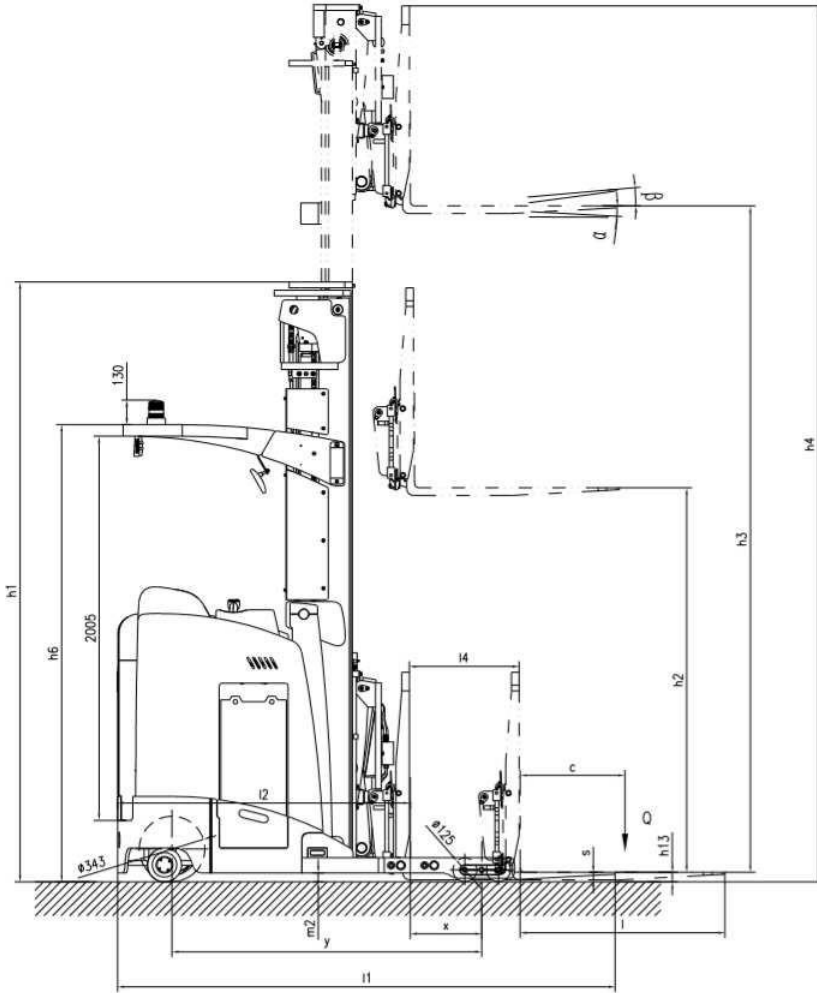

MODEL #	MAST	LIFT HEIGHT	Load Capacity	SERVICE WEIGHT
EK18RR-196Li	96.4"	196"	4,000 lbs.	8700 lbs.



1761 W. Holt Ave.
 Pomona, CA 91768 USA
 T: (877) 232-6517 F: (909) 222-6861

AUTHORIZED DEALERS ONLY
www.ekkolifts.com