

EKKO

MATERIAL HANDLING EQUIPMENT

MOVING **AHEAD**

LITHIUM WALKIE STRADDLE STACKER EB12E-98LI

- Lithium Battery
- 2640 lbs. Capacity
- Lift Height: 98"
- Lower Mast Height: 72"
- Narrow Aisles 7 ft.
- Adjustable Legs 45.5-59.1 in.
- Adjustable Forks 8.3-33.5 in.
- 24V Drive Motor
- Cutis Instrument Controller
- Batteries and Charger Included
- 3 Year Limited Warranty



EB12E-98Li

Superior quality, maneuverable, compact, and durable for all your material handling applications. Ideal for small aisles and areas.

WEIGHT CAPACITY: 2640 lbs. @ 24" load center

LIFT HEIGHT: 98" (8.1 6ft)

FORK LENGTH: 45.3"

ADJUSTABLE OUTRIGGERS: 45.7" - 59.1"

ADJUSTABLE FORKS: 8.3" - 33.5"

MAST HEIGHT: 72"

TURNING RADIUS: 52.6"

BATTERY / CHARGER: LITHIUM IRON PHOSPHATE 24V/50Ah, internal direct connect 110A 110VAC plug-in automatic 24V/15A charger (both Included)

SPEED TRAVEL: 3.3 mph empty ; 3.0 mph loaded

LIFTING SPEED: 5.35 ips empty; 3.6 ips loaded

LOWERING SPEED: 3.85 ips empty; 4.4 ips loaded

DRIVE WHEELS: 9" x 3" polyurethane

LOAD WHEELS: (2) 4" x 3" polyurethane per outrigger

HYDRAULICS LIFTING MOTOR: 24V 2200 Watt lifting motor with hardened chrome moly steel for durability.

DRIVE MOTOR: 24V 750Watt drive motor for efficiency and high torque.

AC CONTROLLER: 24V CURTIS Instrument provides performance through entire range of speed; Constant travel speed regardless of load; Battery discharge indicator combination gauge.

BRAKES: Electro-magnetic braking for secure stopping power; Electronic neutral braking for accurate control.

OPERATOR CONTROLS: Throttle, lifting, lowering, turtle mode and horn functions are located in the ergonomic handle; Offset steering handle to provide better visibility; Belly button reverse safety feature allows the unit to stop and reverse to avoid collision or injury.

CHASSIS AND MAST: Robotic Welding; Heavy duty steel chassis with I-beam mast for durability; Telescoping mast includes a protective steel guard.



Lithium Straddle Stacker

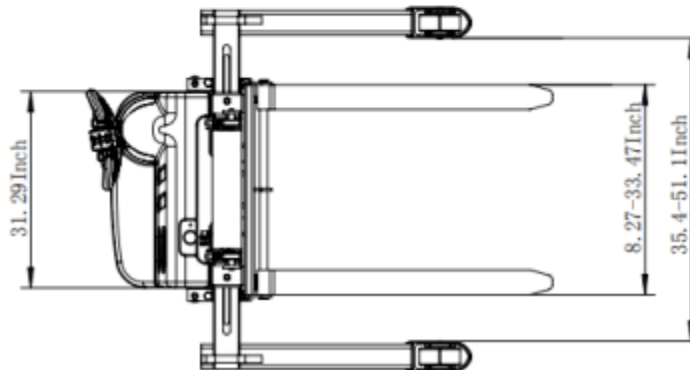
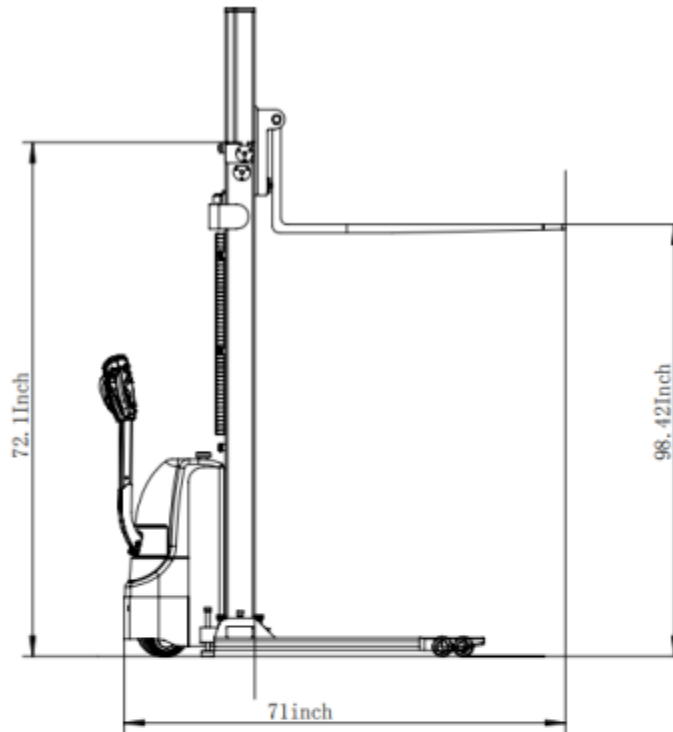

MODEL #	MAST	LIFT HEIGHT	MAX MAST HEIGHT	SERVICE WEIGHT
EB12E-98Li	72"	98"	154"	1300lbs



1761 W. Holt Ave.
Pomona, CA 91768 USA

AUTHORIZED DEALERS ONLY
www.ekkolifts.com

T: (877) 232-6517 F: (909) 222-6861