

# WALKIE STRADDLE STACKER

## EB12E Series

- 2640 lbs. Capacity
- Lift Height: 119.4" | 138"
- Narrow Aisles 8 ft.
- Adjustable Legs 45.7-59.1 in.
- Adjustable Forks 8.3-33.5 in.
- Batteries and Charger Included
- 3 Year Limited Warranty



## EB12E | EB12E-138

**Superior quality, maneuverable, compact, and durable for all your material handling applications. Ideal for small aisles and areas.**

**WEIGHT CAPACITY:** 2640-3000 lbs. @ 24" load center

**LIFT HEIGHT:** 119.4" to 138" (9.95 ft. to 11.5 ft.)

**FORK LENGTH:** 45.3"

**ADJUSTABLE OUTRIGGERS:** 45.7" TO 59.1"

**ADJUSTABLE FORKS:** 8.3" TO 33.5"

**MAST HEIGHT:** 82" or 92"

**TURNING RADIUS:** 52.6"

**INTEGRAL BATTERY/CHARGER:** (2)12V 100AH, 24-volt deep cycle maintenance-free batteries with Internal direct connect 110A 110VAC plug-in automatic 24V/15A charger (both Included)

**SPEED TRAVEL:** 3.3 mph empty; 3.0 mph loaded

**LIFTING SPEED:** 5.35 ips empty; 3.6 ips loaded

**LOWERING SPEED:** 3.85 ips empty; 4.4 ips loaded

**DRIVE WHEELS:** 9" x 3" polyurethane

**STABILITY:** 4"x 2" polyurethane

**LOADWHEELS:** (2) 4"x 3" polyurethane per outrigger

**HYDRAULICS LIFTING MOTOR:** 24V 2200 Watt lifting motor with hardened chrome moly steel for durability.

**DRIVE MOTOR:** 24V 750Watt drive motor for efficiency and high torque.

**AC CONTROLLER:** 24V CURTIS Instrument provides performance through entire range of speed; Constant travel speed regardless of load; Battery discharge indicator combination gauge.

**BRAKES:** Electro-magnetic braking for secure stopping power; Electronic neutral braking for accurate control.

**OPERATOR CONTROLS:** Throttle, lifting, lowering, turtle mode and horn functions are located in the ergonomic handle; Offset steering handle to provide better visibility; Belly button reverse safety feature allows the unit to stop and reverse to avoid collision or injury.

**CHASSIS AND MAST:** Robotic Welding; Heavy duty steel chassis with I-beam mast for durability; Telescoping mast includes a protective steel guard.



# Walkie Straddle Stacker

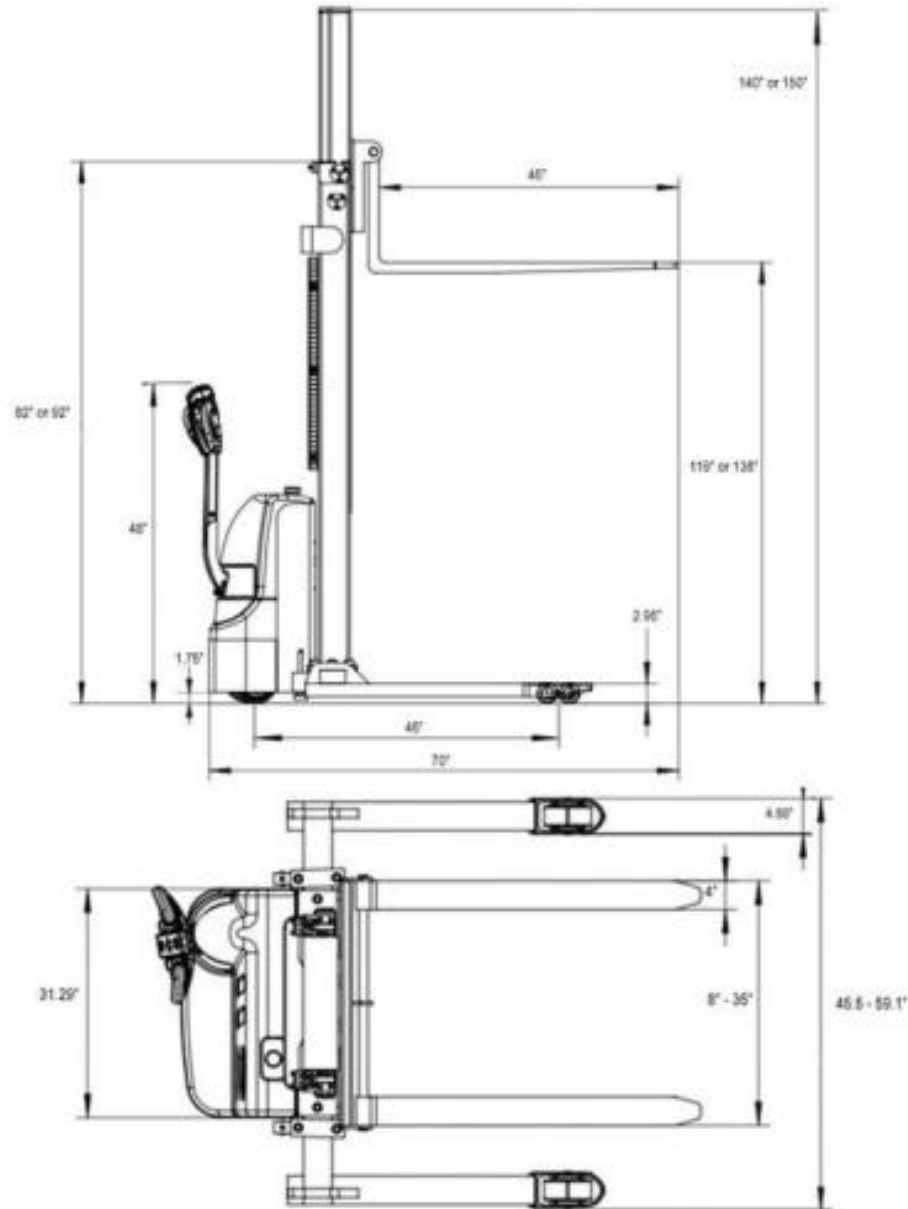

MODEL #	MAST	LIFT HEIGHT	SERVICE WEIGHT
EB12E	82"	119.4"	1420lbs
EB12E-138	92"	138"	1450lbs



1761 W. Holt Ave.

Pomona, CA 91768 USA

T: (877) 232-6517 F: (909) 222-6861

AUTHORIZED DEALERS ONLY

[www.ekkolifts.com](http://www.ekkolifts.com)