

- 3000 lbs. load capacity
- Lift height 177" | 189"
- Triple Mast
- Free Lift
- Synchronous Proportional Valve
- Side Shift
- Dual Damping Drive System
- Polyurethane Tires
- 24V/100Ah Lithium Battery
- Battery & Charger Included



# Lithium Straddle Stacker

## EB14CS-177LI | EB14CS-189LI



Manufacture	EKKO	
Model	EB14CS-177LI   EB14CS-189LI	
Power Type	Electric	
Operating Mode	Walk-behind	
Rated Load Capacity	Q (lbs.)	3000
Load Center Distance	c (in)	20
Wheelbase	y (in)	50.6
Tire Type, Drive Wheel/Load Wheel	Polyurethane Tires	
Drive Wheel Size (Diameter × Width)	in	Φ8.3x2.8
Load Wheel Size (Diameter × Width)	in	Φ3.1x2.8
Lift Height	h3 (in)	177   189
Minimum Fork Height	h13 (in)	2.6
Overall Length	l1 (in)	73.7
Inner Width of Legs	in	35.4 / 39.4 / 43.3 / 47.2 / 51.2
Fork Dimensions	s/e/l	1.4 × 4.0 × 45.3
Fork Adjustment Range (Fork Outer Width)	b5 (in)	8.7 - 32.1
Minimum Ground Clearance at Wheelbase Center	m2(in)	1.2
Minimum Turning Radius	Wa(in)	60.8
Travel Speed, Laden/Unladen	mph	2.5 / 2.5
Lift Speed, Laden/Unladen	in/s	3.9 / 4.9
Climbing Speed, Laden/Unladen	%	5/10
Service Brake	Electromagnetic	
Drive Motor Power	kw	0.75
Lift Motor Power	kw	2.2
Battery Voltage/Rated Capacity	(V)/(Ah)	24/100 Lithium
Type of Drive Control	DC	
Steering Type	Mechanical	
Noise Level at Operator's Ear	dB(A)	<70

# Lithium Straddle Stacker

EB14CS-177LI | EB14CS-189LI

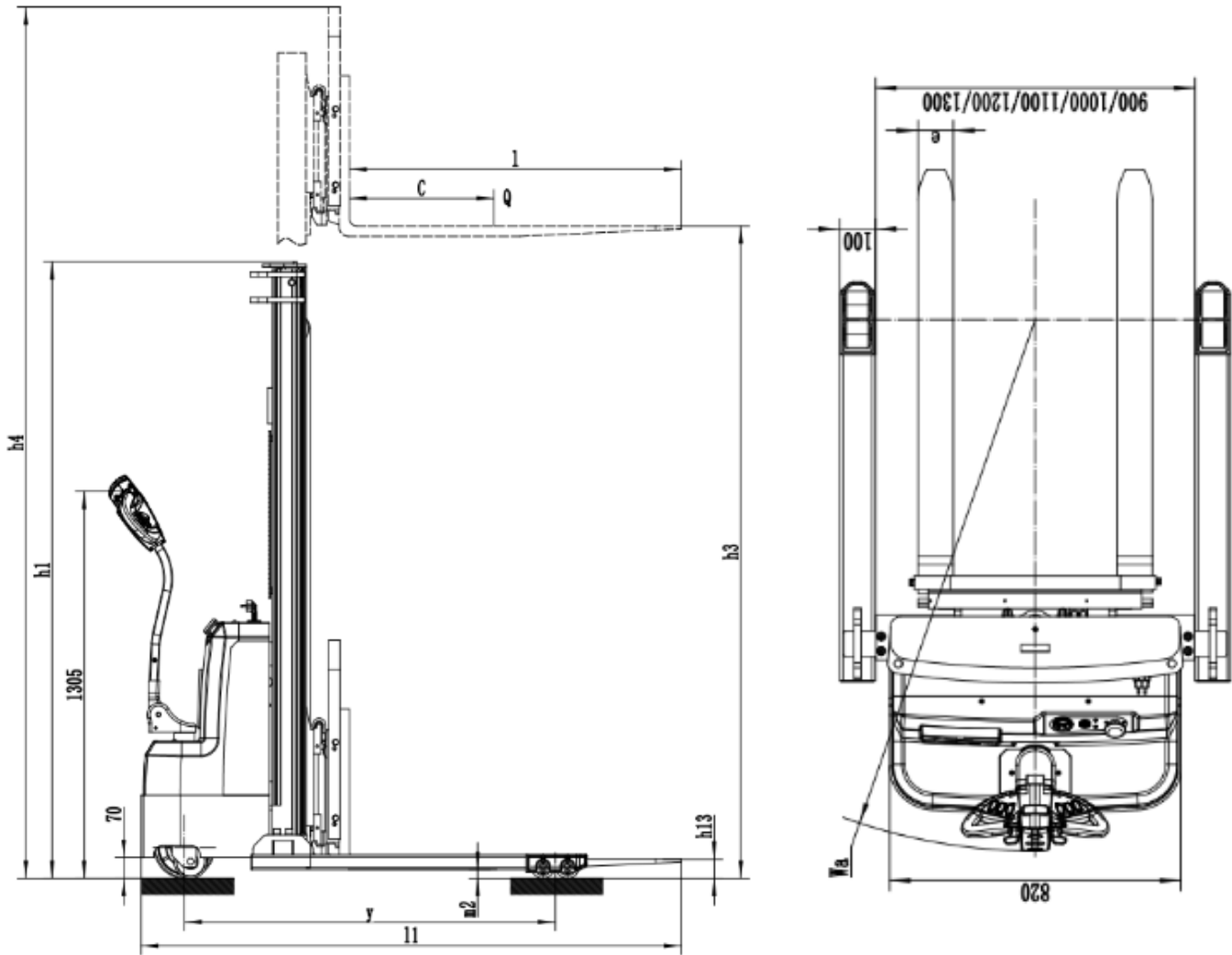

MODEL #	MAST	LIFT HEIGHT	MAX MAST HEIGHT	SERVICE WEIGHT
EB14CS-177LI	N/A	177"	N/A	N/A
EB14CS-189LI	N/A	189"	N/A	N/A



1761 W. Holt Ave.

Pomona, CA 91768 USA

AUTHORIZED DEALERS ONLY

[www.ekkolifts.com](http://www.ekkolifts.com)

T: (877) 232-6517 F: (909) 222-6861