

EP30A / EP30A-LI

FULL ELECTRIC RIDER PALLET TRUCK

INSTRUCTION MANUAL



WARNING

The operating instructions on this manual must be thoroughly understood before using the manual.

Caution:

- Check the identification of the product type on this document and the nameplate.
- Keep this document properly for future use.

EKKO[®]
MATERIAL HANDLING EQUIPMENT
MOVING AHEAD

Preface

Before operating this pallet truck, please read this operating manual carefully and fully understand its usage methods. Improper operation may cause hazards.

This manual describes the operating methods for different types of pallet trucks. When performing maintenance, ensure it corresponds to your company's specific model.

Please keep this manual properly for future reference. If this manual or any warning/caution labels are damaged or lost, please contact your local dealer for replacement.

This pallet truck complies with the following standards: EN 3691-1 (Industrial trucks – Safety requirements and verification, Part 1), EN 12895 (Industrial trucks – Electromagnetic compatibility), EN 12053 (Safety of industrial trucks – Test methods for measuring noise emissions), EN 1175 (Safety of industrial trucks – Electrical requirements). It must be used in accordance with the intended purposes specified in these standards.

According to EN 12053, the noise level at the operator's ear is less than 70 dB(A).

Note:

Hazardous waste that is harmful to the environment, such as waste batteries, waste oil, and electronic products, may negatively affect the ecological environment or human health if not handled properly.

Waste packaging should be sorted into solid waste bins according to the material and collected and treated by the local environmental protection agency. To avoid pollution, random littering is prohibited.

To prevent oil leakage during product use, users should prepare some absorbent materials (such as waste wood chips or dry cloths) to promptly absorb any leaking oil. To prevent secondary environmental pollution, used absorbent materials should be handed over to specialized departments according to local authority regulations.

Our product is subject to continuous improvement. Please be advised that this manual is intended solely for the operation/maintenance of the handling equipment, and therefore cannot guarantee performance under exceptional circumstances beyond its specified scope.



Note: In this manual, the symbols on the left indicate warnings and hazardous situations which, if not observed, may result in death or serious injury.

Table of Contents

- 1、 Proper Use
- 2、 Vehicle Technical Parameters
- 3、 Training Receipt
- 4、 Self-Protection
- 5、 Benefits
- 6、 Your Pedestrian Pallet Truck
- 7、 Vehicle Components
- 8、 Operating and Usage Instructions
- 9、 Daily Safety Checks
- 10、 Be a Safe Operator
- 11、 Battery Maintenance
- 12、 Hydraulic Schematic
- 13、 Electrical Schematic

1、 Proper Use

This pallet truck may only be used in accordance with this instruction manual.

The truck described in this manual is a pedestrian pallet truck with electrically operated height adjustment. It is designed for lifting, lowering, and transporting palletized loads.

Improper use can lead to personal injury or machine damage.

The operator/operating company is responsible for ensuring correct use and that this truck is operated only by personnel who are trained and authorized to do so.

This truck is to be used on a firm, level, intact surface with adequate load-bearing capacity. It is intended for indoor use at ambient temperatures between +5°C and +40°C and for light-duty applications without permanent obstructions or trenches. Operation on slopes is prohibited. During operation, the load must be positioned at the approximate center of the truck.

It is strictly forbidden to lift or transport persons.

When used on tail lifts or loading platforms, ensure these are operated correctly according to their instructions.

The rated capacity is indicated on the load plate and nameplate. The operator must heed these warning labels and safety instructions.

The minimum operating illumination must be 50 lux.

Modifications

Any modifications or alterations that could affect the truck's rated capacity, stability, or safe operation require prior written approval from the original manufacturer or its authorized representative or successor. This includes changes affecting aspects such as braking, steering, visibility, or the addition of removable attachments. If modifications or changes are approved by the manufacturer or its successor, the load plate, labels, identification markings, and operation and maintenance manuals must be updated accordingly.

Damage resulting from failure to follow these instructions will void the warranty.

2、 Vehicle Technical Parameters

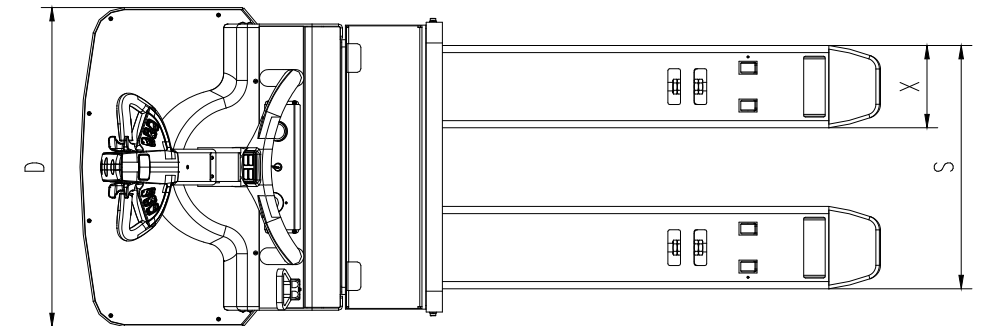
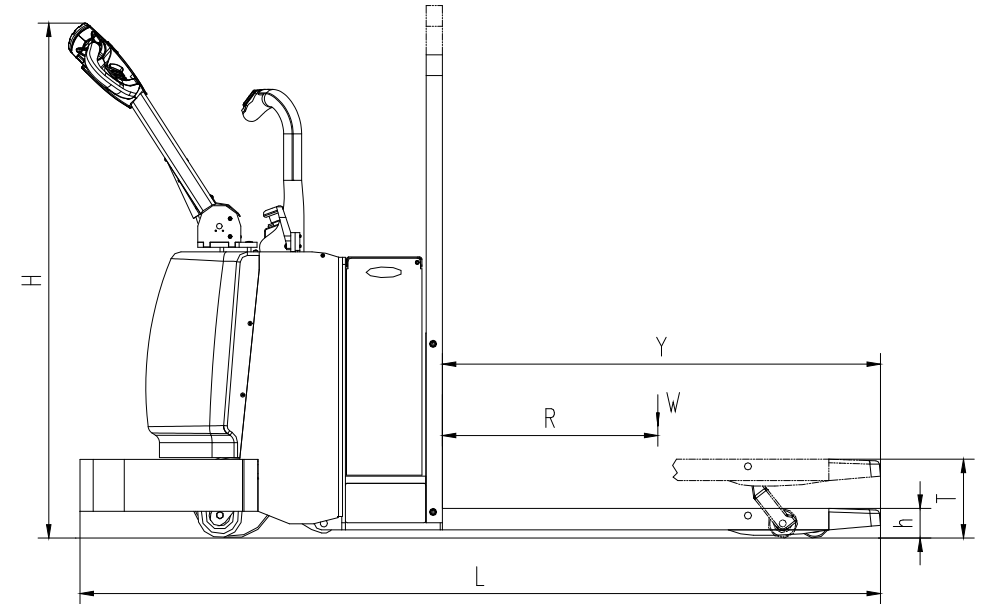

3、 Training Receipt

Product Name & Specifications	Hand Pallet Truck	EP30A / EP30A-LI
Basic Parameters	Fork Length (Y)	1220 mm
	Fork Outer Width (S)	680mm
	Fork Width (X)	230mm
	Fork Height (h)	83 mm
	Lifting/Lowering Speed(m/s)	0.03/0.04
	Overall Length (L)	2238mm
	Overall Width (D)	892 mm
	Overall Height (H)	1440mm
	Bolts/Nuts	Grade 8.8
	Lifting Height (T)	230mm
	Load Weight (W)	3.0T
	Load Center (R)	600mm

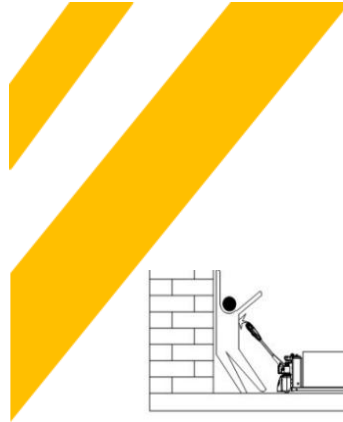

In your workplace, you lack training and certification qualifications. Insufficient vehicle operation training may endanger your own life!

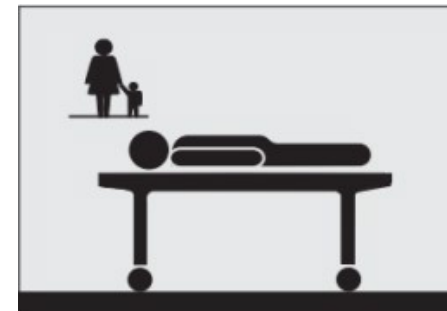

warning

Regulations require that operators must undergo training and certification before operating this vehicle.

Improper use of the vehicle may endanger the lives and safety of both the operator and others.

Read and comply with all warnings and instructions in the operator's manual.

Falling from loading docks or dock plates may result in serious injury or even death. Ensure your safety.

Inspect the vehicle before starting work to ensure it is in proper working condition.



According to legal provisions, only properly trained operators may operate the vehicle. Your employer must train you and certify your qualification to operate the vehicle.

4、 Self-Protection



Understand Hazards

Observe the moving area.

Always be vigilant of the surrounding area and pay attention to where you are driving. Be careful to avoid collisions (such as between walls or pillars).

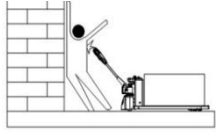

Drive with caution.

Avoid crushing or injuring your own hands and feet. When driving sideways, prevent collisions with legs or feet to avoid crushing them.

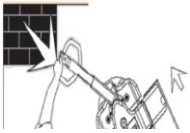

When starting the lifting cart, grip the handlebars firmly with both hands, change direction carefully, and keep both feet away from the cart.



Maintain control of the forklift and operate at a safe speed. Drive with caution on slippery or uneven surfaces, and do not run over foreign objects on the ground.

Avoid Falls

Falls are very serious accidents, and you may be crushed or even killed. The best way to prevent injury is to always know your location and follow safe operating rules.

Exercise extreme caution when working around docks, loading platforms, and trailers. Stay away from the edges of docks and ramps.

Ensure dock plates are secure.

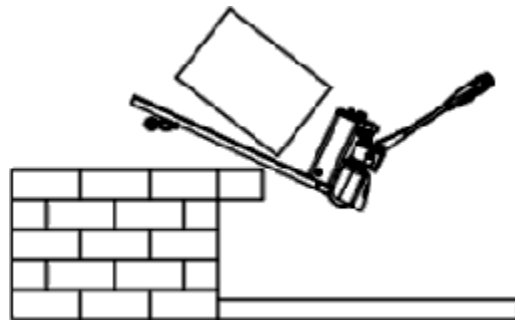

Safe Operation of Forklift Trucks

Keep hands and feet away from all moving parts, such as forks or wheels.

Never ride on or allow others to ride on the forklift, and do not sit or stand in hazardous positions.

Before leaving the truck:

Lower the forks to the floor.

Turn off the forklift ignition.



5、 Benefits

What Are the Benefits to You?

The more you understand your forklift truck and how to use it, the better and safer operator you can become. Here are some guidelines for using this manual.

Quick Navigation

In addition to the "Contents" page, you can use the page headings to locate topics. Some pages also include a picture of the truck in the corner, showing the feature or function covered on that page.

How-To Instructions

On many pages, you will find pictures and text to help you understand how to operate this forklift truck safely and efficiently.

Understanding Hazards

Pay attention to and read these special alert symbols. You will find information on potential safety risks and how to avoid them.

6、 Your Pedestrian Pallet Truck

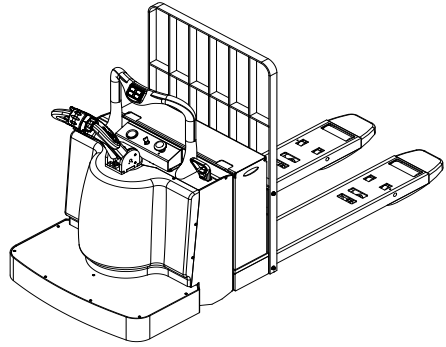

Manufactured to Standard

This forklift is designed and manufactured in accordance with current industry and governmental standards and guidelines. It is suitable for moving and handling in short distances and confined spaces.

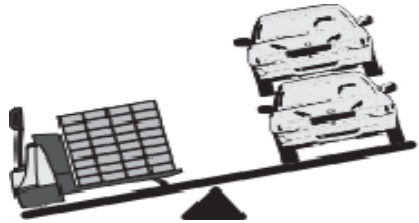

Powerful and robust, capable of easily lifting two small cars. Distinctive steering. A different braking system.



When operating the forklift for the first time, use both hands to operate the control handle. If you change the travel direction, pay attention to your feet.

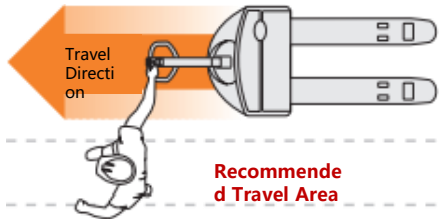

When initially traveling under power, remain on one side of the vehicle, slightly ahead of the drive unit. Use the hand closest to the forklift to operate the control handle. Watch your feet. Keep clear of the forklift's travel path.

7、 Vehicle Components

7.1 Steering Handle

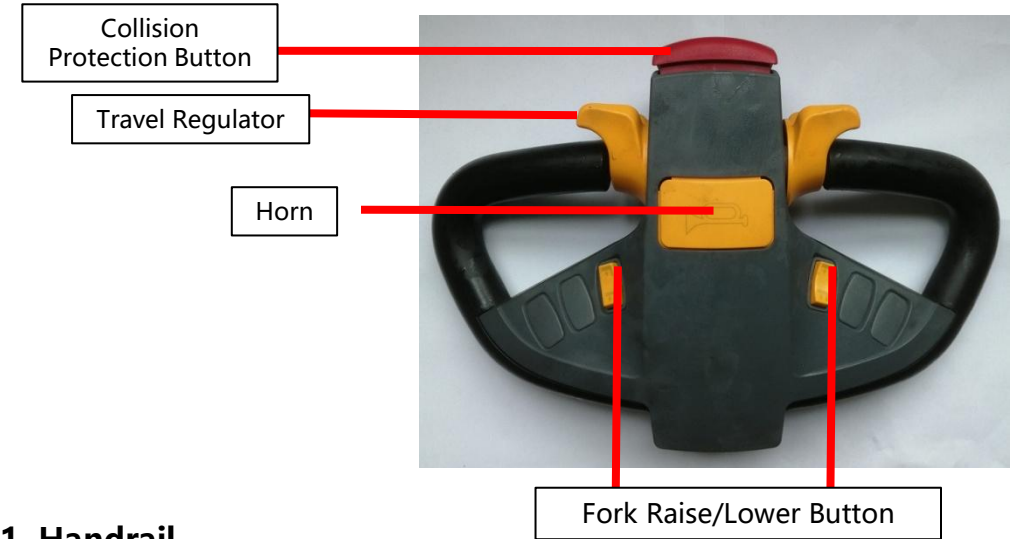

7.1 Handrail



8. Operating and Usage Instructions

A. Key Switch

Start the vehicle by inserting the key into the key switch and rotating it 45° (as shown in Figure 1). Turn off the vehicle by rotating and removing the key. Always turn off the key switch when leaving the vehicle.

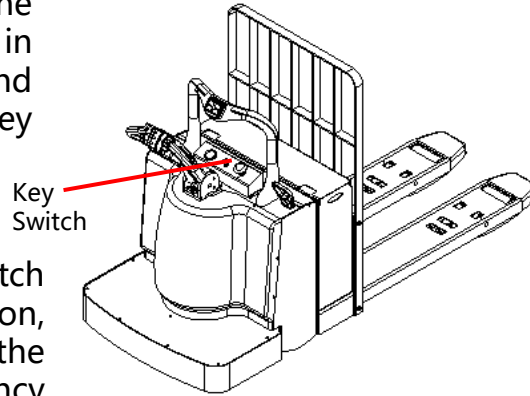

Figure 1

B. Emergency Reverse

If you touch the emergency reverse switch while the vehicle is moving toward a person, the forklift will travel in the direction of the forks (as shown in Figure 1). The emergency reverse cannot prevent all injuries.

C. Slow Travel

Press the turtle switch on the control handle, then turn the forward/reverse rocker. (as shown in Figure 1)

D. Power Level

Display the remaining power status (as shown in Figure 1).

E. Disconnect Power Supply

Press the red E-STOP switch to disconnect the battery and cut off all power (as shown in Figure 2). Always disconnect the battery whenever the vehicle does not operate normally. The key switch does not cut off all power to the vehicle. If the vehicle is not functioning properly, do not use the vehicle and report the issue to your supervisor.

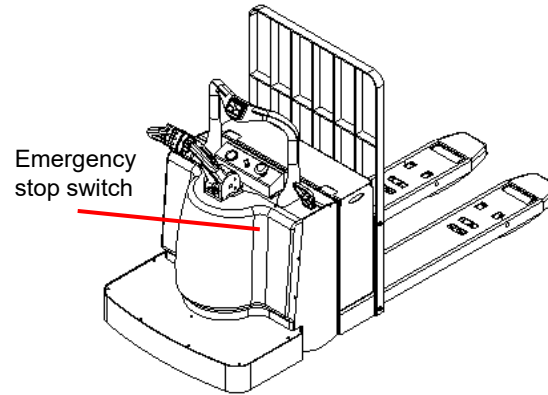

Figure 2

G. Brake Override

If the truck must be moved in a confined area, place the handle in the brake area, press the turtle speed switch (as shown in Figure 3), the indicator light is red, and turn the forward/reverse button to the slow travel position.



Understand Danger

Ensure your brakes are effective by testing the vehicle's brakes at the beginning of each shift.

H. Raising or lowering

Press the lift button (see Figure 4) until the front fork reaches the desired height, then release the button.



Figure 5

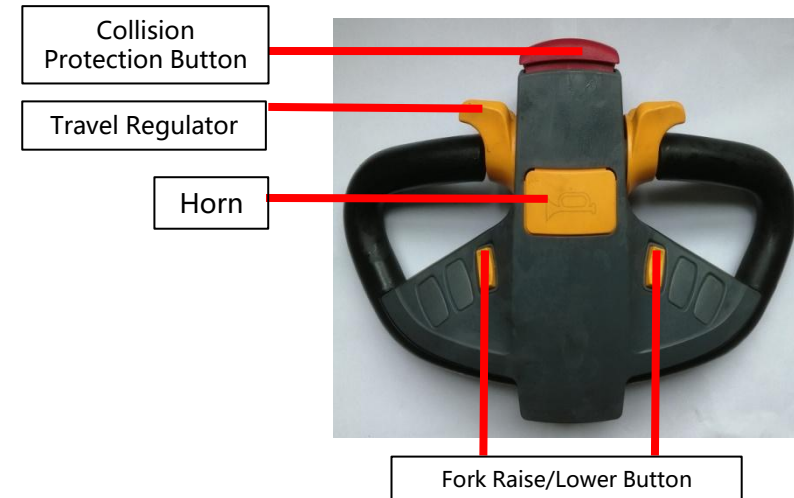

Figure 4

I. Horn

Used for warning and alerting (As shown in Figure 4)

J. Steering

You can control the steering by moving the control handle from one side to the other. For example: This diagram shows the direction in which the vehicle can steer when the control handle is moved to the approximate position indicated. (as shown in Figure 5)

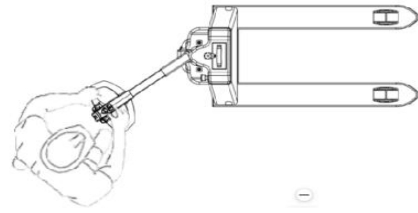

Figure 5

K. Driving

Push the drive controller in the direction you wish to travel. The further the rocker arm is moved from the neutral position, the faster the vehicle moves. (As shown in Figure 4)

Understand Hazards

a. Drive Steering

Exercise caution when turning while in motion. The power unit will swing in the opposite direction. Ensure you have ample space and be mindful of personnel in the area.

(As shown in Figure 6)

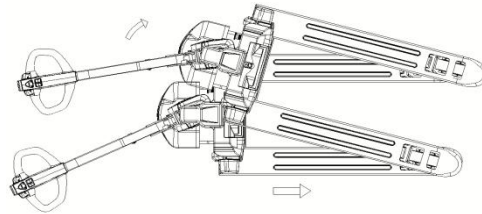

Figure 6

b. Slippery Surfaces, Proceed Slowly

Powder or liquid spills can cause floors to become slippery. Reduce speed; otherwise, you may lose control of steering and braking. Exercise caution and allow for a longer stopping distance. Do not run over objects on the floor (as shown in Fig. 7).



Figure 7

9. Daily Safety Checks

**Inspect your truck before starting work.
You must ensure your truck is safe to operate.**

1. Walk around and inspect your forklift.

Ensure the battery is charged. Do not use open flames to check the battery.

Check battery cables and connectors for damage or corrosion. Inspect all wheels for good condition.

Clean the control handle.

Check that both forks are straight, without cracks or severe wear. If your truck is equipped with the option, ensure the load backrest is in place and secured.

Look under the vehicle for signs of hydraulic leaks.

Test the horn.

Ensure all controls operate smoothly.

2. Test your vehicle in an uncrowded area.

Test the hydraulic functions.

Check the steering.

Operate the vehicle slowly in both directions.

Run at full speed in both forward and reverse.

Check the braking distances in forward and reverse. Load size and floor conditions will affect these distances.

Before starting work, understand the distance required to stop. If the braking distance is too long to stop safely, do not use the vehicle.

If anything looks, works, or feels wrong, do not use the vehicle. Report the problem to your supervisor.

10、 Be a Safe Operator

- **Ensure you are prepared and ready.**

Do not operate the vehicle unless you are properly selected and certified. Ensure you understand how the vehicle works and the hazards involved. If you have any doubts, do not use the vehicle.

Understand the load capacity of the vehicle.

Some vehicles are not permitted in fire hazard areas. Make sure your vehicle is the correct fire safety type suitable for the job.

Ensure your hands and shoes are clean and dry, and your clothing is appropriate for the work.

• **Ensure Your Vehicle is Ready for Use**

- **Ensure Your Vehicle is Ready for Use**

Inspect your vehicle before use. If it is not functioning properly, or if something is broken, report the issue to a supervisor. Do not use the vehicle.

In an open area, test the brakes. First drive at a slow speed, then at faster speeds to check.

Know how long it takes to stop before starting work.

For wet or slippery floors, slow down, avoid running over objects, and be mindful of rough surfaces.

Ensure you have enough space to turn, and pay attention to vehicle sway.

Reduce speed when turning to avoid sudden movements; operate the vehicle at a moderate, steady pace.

If you must use the vehicle in an area with a risk of falling objects, exercise extra caution.

- **Pay attention to others.**

Proceed slowly, yield or stop for pedestrians. When approaching intersections or crossings, sound the horn.

Be careful not to hit anyone.

Do not allow anyone to ride on the vehicle.

When the vehicle is in operation, others should keep a safe distance.

No one should operate the vehicle without proper training and certification.



- **Drive carefully on ramps and slopes**

Keep away from the vehicle's path.

Whether loaded or unloaded, always travel with the forks pointing downhill.

If the load requires special forks, pay extra attention; steer the vehicle from the side. Reduce speed and do not turn on ramps or slopes.

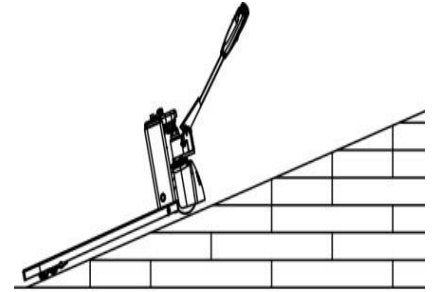

- **Avoid Falling**

Keep away from the edges of docks and ramps.

Inspect loading platforms and dock plates for stability. Ensure wheels are chocked against the dock.

Check the load to ensure your vehicle is not overloaded.

Ensure the cargo being moved is stable and centered. Exercise extra caution with overlong, overhigh, or overwide loads, as they may be less stable.

Do not force forklifts onto elevators unless authorized.

Check load capacity or load limits to ensure no personnel are present.

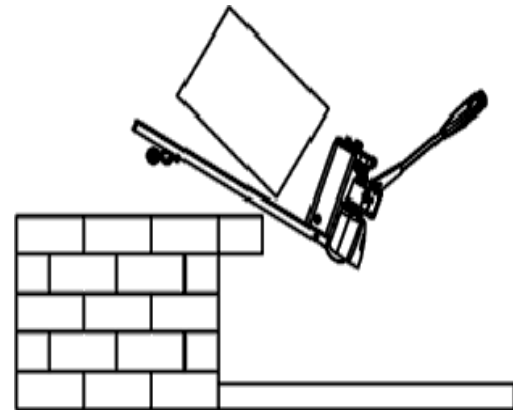

11、 Battery Maintenance

Battery Charging

- ① Connect the charger plug to the battery power plug, then turn on the charger to start charging the battery.
- ② Ensure proper ventilation during charging. Smoking or using open flames is strictly prohibited.
- ③ After charging, first turn off the charging power supply and the charger, then unplug the charger.
- ④ Perform relevant maintenance on the battery after charging.

Charger Usage and Precautions

- ① The charger provided for the transport vehicle features precise constant current characteristics and rapid over-current protection capability, automatically stabilizing output current when voltage fluctuates.
- ② Follow the "Product User Manual" and "Product Specification Sheet" during use. Do not violate relevant regulations.
- ③ Pay attention to waterproofing, moisture prevention, and static electricity protection during use.
- ④ The battery should be stored in a dry and cool place. If not used for more than 3 months, recharge it once to ensure battery lifespan. This specification of battery is maintenance-free and does not produce hydrogen gas hazards.
- ⑤ Do not throw the battery into fire or heat it. Do not immerse the battery in water or get it wet.
- ⑥ Do not short-circuit the battery's positive and negative terminals or cause a short circuit with metal objects. Do not transport the battery together with other metal objects.

12、 Hydraulic Schematic

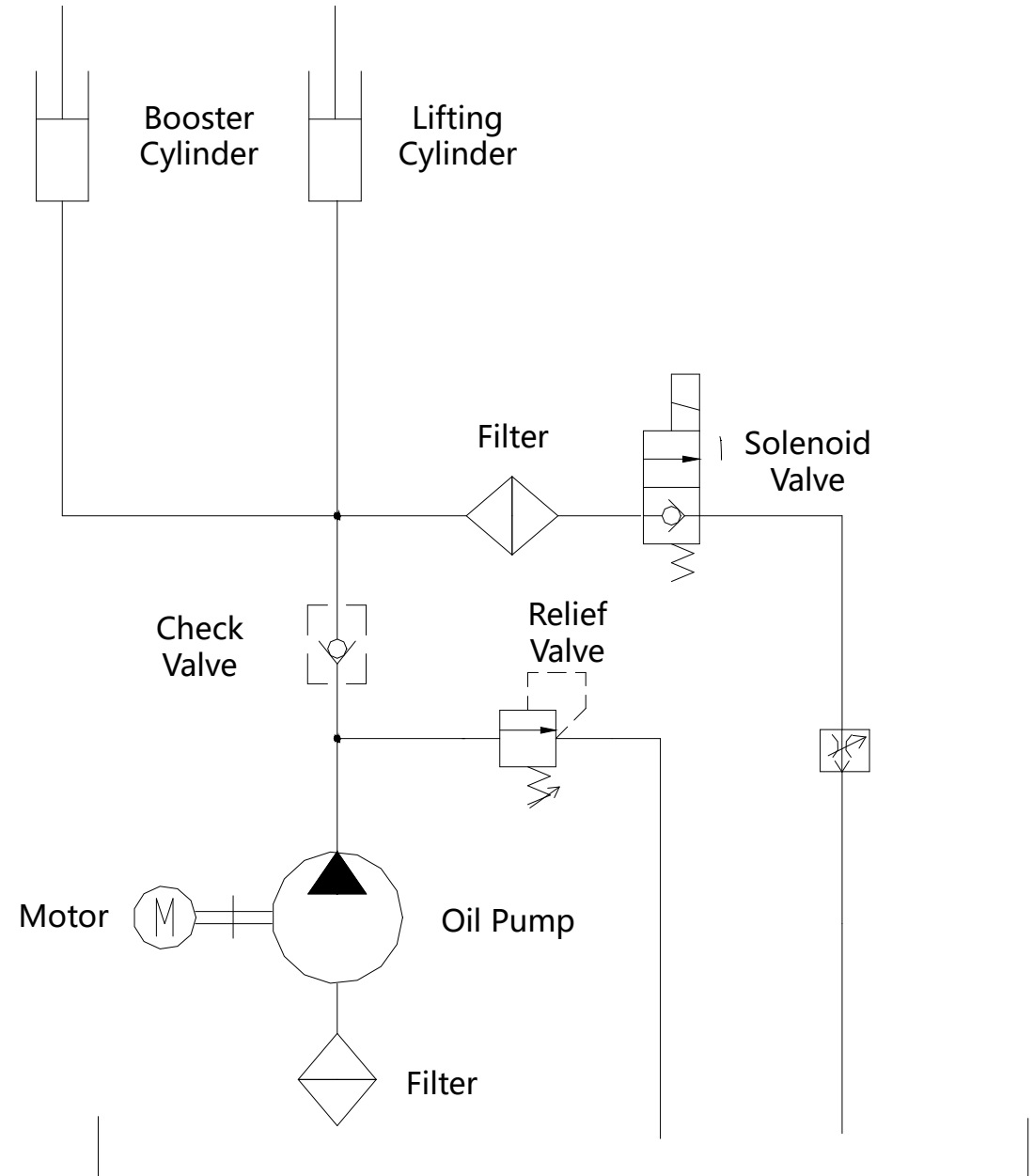

13、Electrical Schematic

