



Operational & Maintenance Manual

Semi-Electric Stacker

EA15A-118 / EA15A-138





Caution

Please pay attention to the following items before using the stacker:

1. EA15A stacker should only be used indoors on even and solid ground. It is prohibited to use the stacker in environments with flammable or caustic substances, such as acids or alkalis.
2. Read the instructions carefully before operating the stacker and familiarize yourself with its operation. Check the stacker's condition before use. Do not operate the stacker if it is faulty.
3. Overloading is prohibited. The load capacity and load center should adhere to the specifications outlined in the instruction manual.
4. When using the EA15A stacker, ensure the load's center of gravity is within the range of the two forks. Do not use the stacker for unstable or loose materials.
5. For long-distance transportation, the fork height should not exceed 19.5".
6. When stacking, no one should be positioned under the forks or near the stacker.
7. Do not stand on the forks while the stacker is in operation.
8. Turn off the power supply after use.

1. Application

The EA15A stacker is an economical stacker that uses a lead-acid battery for lifting power.

It features smooth lifting and lowering, ease of operation, and simple maintenance. The stacker is equipped with a brake on the universal wheels for safety and reliability. It is designed for the transportation and stacking of small goods. This stacker is an ideal tool for reducing labor intensity, improving production efficiency, and ensuring safe operation.

3. Structural features

The EA15A Semi-electric stacker is mainly composed of hydraulic system, mast and lifting forks.

1. The stacker uses a motor-driven hydraulic system to lift goods, with manual effort required to push and pull the stacker. The hydraulic system consists of a hydraulic pump and oil cylinder, which raise or lower the load by operating the control lever.
2. An explosion-proof valve is installed at the bottom of the oil cylinder to ensure that the forks do not drop rapidly, even in the event of an oil line failure.
3. The mast is made from 16Mn steel tubing, offering excellent rigidity and lightweight construction.
4. The rear wheels are universal wheels with brakes, allowing for smooth, flexible, and easy rotation.
5. The stacker is equipped with an over-discharge protection controller for the battery, preventing damage caused by over-discharging.

4. Service conditions

The operation of the EA51A Semi-electric stacker should meet following conditions:

1. Ambient temperature: $-13^{\circ}\text{F}\sim+104^{\circ}\text{F}$.
2. Ambient relative humidity: $< 90\%RH$.
3. Environment free from moisture and harmful gases.
4. The EA15A semi-electric stacker is not an explosion-proof product. It is forbidden to use it in areas with flammable gases.

5. Operation

The operation of the EA15A semi-electric stacker is simple.

1. Pull the red emergency stop switch and turn the key to the right to unlock the electric door lock. If the voltmeter light is on, the stacker is in ready mode.
2. Pull the control lever to raise the forks.
3. Push the control lever to lower the forks.
4. The speed of descent can be controlled by adjusting the pressure on the control lever.

5. The brake on the rear wheels ensures safe operation. When lifting or lowering goods, engage the brake to prevent the wheels from rolling.
6. When the voltmeter shows a red indicator, the battery should be charged. The stacker will enter a lifting protection mode when the last two red lights blink alternately. At that point, the forks cannot be raised to prevent the battery from over-discharging.
7. To charge the battery, press the emergency stop switch and turn off the electric door lock. Plug the charger into the jack on the side of the electrical box, connect the power supply, and turn on the charger's power switch.
8. Once properly connected, the charger will begin charging. The POWER indicator on the charger will light up, indicating that it is working. The CHARGE indicator will light up to show that the stacker is charging, and the FULL indicator will light up when charging is complete.
9. The hydraulic oil must be filtered, and the pump should always have enough oil. Replace the oil based on usage and the cleanliness of the hydraulic fluid. Use only LHPISOVG46 hydraulic oil that complies with the DIN 51524 T.2 standard.
10. After use, unload the goods. Do not leave weight on the forks for extended periods.

6. Possible faults and solutions

| No. | Faults | Causes | Solutions |
|-----|--|--|--|
| 1 | The voltmeter has no signals when power on. | The 10A fuse of the top broke off or supply switch damaged. | Replace the fuse or supply switch. |
| 2 | It cannot reach the designed lifting height. | Lack of hydraulic oil. | Add hydraulic oil. |
| 3 | There's noise from motor pump in the hydraulic station, but the forks cannot lift or fall. | There's block at the solenoid valve core. | Remove it and clean with gasoline or kerosene. |
| 4 | When power is on, the coulomb meter shows the number, but the forks don't work. | 175A fuse in lifting loop broke off or the battery-protect controller damaged. | Replace the fuse. If it broke off again, check the loop and see if there's any open circuit or bad elements. |
| 5 | Oil impregnation or leakage. | Seal washer damaged or screw joint loosened. | Replace a new seal washer or screw down. |

7. Use, maintenance and charging of the battery

7.1 Initial charge

Note: The charging environment must have good ventilation, and there should be no open flames; otherwise, an explosion may occur.

The initial charge should be conducted for batteries that have never been used. Before the initial charge, clean the surface of the batteries and check for any damage. The bolts should be tightened to ensure a reliable connection.

Remove the sealing cover and replace it with the open-cover type liquid hole plug, then open the cover.

Pour sulfuric acid electrolytic solution with a density of 1.260 ± 0.005 (77°F) and a temperature below 86°F, into the batteries while ensuring that the charging equipment is operating normally. The liquid level should be 1.5–2.5 cm higher than the protective board. To minimize temperature rise caused by the chemical reaction of the electrolytic solution and to allow the solution to penetrate the pores of the polar plates and baffles, the batteries should remain stationary for 3 to 4 hours, but no longer than 8 hours. Initial charging can only begin once the temperature of the solution has cooled to below 95°F. (If necessary, the batteries can be placed in cold water to reduce the temperature.) After this stationary period, if the solution level has dropped, additional electrolytic solution should be added.

The sulfuric acid electrolytic solution is prepared using battery-grade sulfuric acid that complies with the state standard GB 4554-84 and distilled water. Never substitute industrial sulfuric acid or tap water for these materials. The standard temperature (77°F) and density of the electrolytic solution can be converted using the following formula:

$$D_{25} = D_t + 0.0007(t_f - 32)$$

Here: D_{25} is the density of the electrolytic solution at 77°F.

D_t is the actual density of the electrolytic solution at temperature °F.

t is the electrolytic solution temperature while testing the density.

Sweep the electrolytic solution onto the surface of the batteries, then connect the positive and negative terminals of the battery group to the corresponding positive and negative terminals of the DC power supply (charger).

Fully Charged Status: The EA15A stacker uses an intelligent charger that will stop charging once the battery is fully charged. (The first charging cycle may take longer, while the standard charging time is 10-12 hours.)

To accurately control the sulfuric acid content of the electrolytic solution, the solution density of the batteries should be checked during the final stage of charging. If it is inconsistent, adjust the density with distilled water or sulfuric acid (with a density of 1.40). The electrolyte density and liquid level should be adjusted to the specified values within two hours while the battery is still charging.

After the initial charging is complete, the surface of the batteries should be cleaned. Close the cover of the open-type liquid hole plug, and only then can the batteries be used.

7.2 Use and maintenance

To ensure the service life of the batteries, all batteries in use should be fully charged. Insufficiently charged batteries must not be used. During operation, close attention should be paid to the discharge level. Over-discharge is prohibited—voltage should not drop below 1.8V per battery (which equals 10.8V for a 6-battery system). When the density of the electrolytic solution drops to 1.17, discharge should be stopped immediately, and charging should begin right away. Batteries should not be left idle for long periods. The supplementary charging performed during use is referred to as "maintenance charging."

Maintenance Charging: The charging method is the same as the initial charge. The charged volume should be 130-140% of the discharged volume, and the charging time is approximately 12 hours.

Batteries in normal use should avoid overcharging. However, overcharging must be performed properly if the batteries are in the following situation: balance charging.

- a. The "lag-behind" batteries—those with a lower voltage than the other batteries during the discharging process, and batteries that have been repaired due to failure—should be treated as follows: When balance charging is conducted, the positive and negative terminals of the "lag-behind" battery should be connected to the corresponding positive and negative terminals of the DC power supply, and charging should be performed independently
- b. Balance charging should be conducted for batteries in normal use every 2-3 months.
- c. Balance charging should be performed on batteries that have not been used for an extended period before they are put into use.

Balance charge:

- a. Charge with a 4A current.
- b. When the charge voltage reaches 14.6V ($6 \times 2.6V = 14.6V$) and air bubbles appear in the electrolytic solution, reduce the current by 50% (to 2A) and continue charging.
- c. Once the batteries are fully charged, stop charging for 0.5 hours, then recharge with a 1A current for an additional hour.
- d. After another 0.5-hour pause, charge with a 1A current for another hour.
- e. Repeat step d until air bubbles appear vigorously in the batteries once the charger is switched on..

7.3 Storage

Batteries should be stored in a clean, dry, and well-ventilated warehouse with a temperature range of 41-104°F. The recommended shelf life is 2 years. During storage, the batteries should be kept according to the following guidelines:

- a. The batteries should not be exposed to direct sunlight and must be kept at least 2 meters away from heat sources.
- b. Avoid contact with any harmful substances. No metallic objects should be allowed to fall into the batteries.
- c. The batteries must not be stored upside down, and they should be protected from mechanical impact or heavy loads.
- d. The batteries must not be stored with the electrolytic solution. If storage with electrolytic solution

is required under special circumstances, the batteries should be fully charged, and the density and liquid level should be adjusted to the rated values. After one month of storage, the batteries should be recharged using the standard charging method.

1.1. Final assembly

| No. | Description | Material code | Qty. |
|-----|---------------------------------------|---------------|------|
| 1 | Mesh enclosure | BDA-00004 | 1 |
| 2 | Fixed climb | BDA-00001 | 4 |
| 3 | Bolt M6×12 | T-LD-006 | 4 |
| 4 | Back cover | BDA-00028 | 1 |
| 5 | Battery (12V/120Ah) | BDA-00027 | 1 |
| 6 | Hydraulic station 12V/1.6KW | BDA-00023 | 1 |
| 7 | Hexagon socket head cap screws M10×20 | T-LD-086 | 2 |
| 8 | Pin roll Φ20*81 | BDA-00006 | 1 |
| 9 | Shield d20 | T-DQ-004 | 6 |
| 10 | Brake assembly | BDA-00029 | 1 |
| 11 | Hexnut M10 | T-LM-001 | 4 |
| 12 | Universal wheel assembly | BDA-04036 | 2 |
| 13 | Wheel Φ180*50 | SBA-00061 | 2 |
| 14 | Lining Φ20*Φ12*55 | BDA-04031 | 2 |
| 15 | Deep groove ball bearing 60204 | T-ZC-007 | 4 |
| 16 | Bushing | BDA-04030 | 2 |
| 17 | Outer hexagon bolt M12*93 | T-LD-003 | 2 |
| 18 | Locknut M12 | T-LM-003 | 2 |
| 19 | Fork assembly | BDA-B7000 | 1 |
| 20 | Battery connector CHJ-2/50A | DQ-020 | 1 |
| 21 | I-shape nonmetal inserts locknut M3 | T-LM-007 | 2 |
| 22 | Hexagon socket head cap screws M3*25 | T-LD-044 | 2 |
| 23 | Nylon fork wheel Φ80x93 | SBA-00022 | 2 |
| 24 | Deep groove ball bearing 60204 | T-ZC-007 | 4 |
| 25 | Lining | BDA-04030 | 2 |
| 26 | Front wheel axle Φ20*123 | BDA-00017 | 4 |
| 27 | Outer hexagon bolt M10*25 | T-LD-010 | 4 |
| 28 | Mast welding assembly | BD-05001 | 1 |
| 29 | Cross-shaped sunk screw M5X10 | T-LD-045 | 2 |
| 30 | Emergency stop switch | DQ-030 | 1 |
| 31 | Round voltameter BI1201B | DQ-029 | 1 |
| 32 | Electric door lock 25VDC/10A | DQ-031 | 1 |
| 33 | Outer hexagon bolt M10*45 | T-LD-052 | 4 |

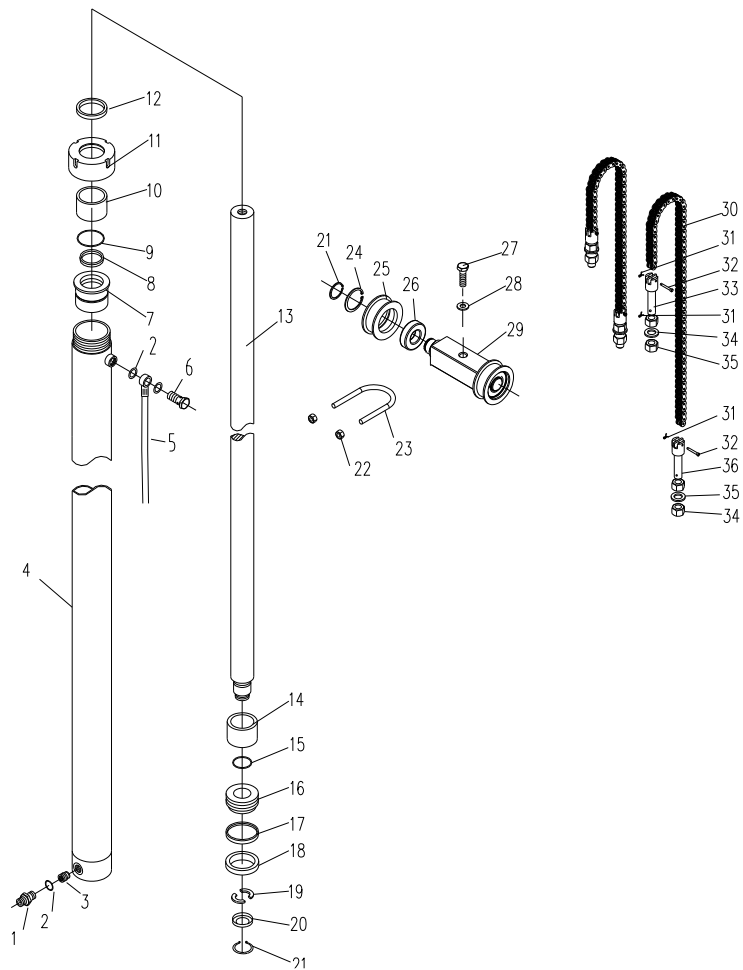
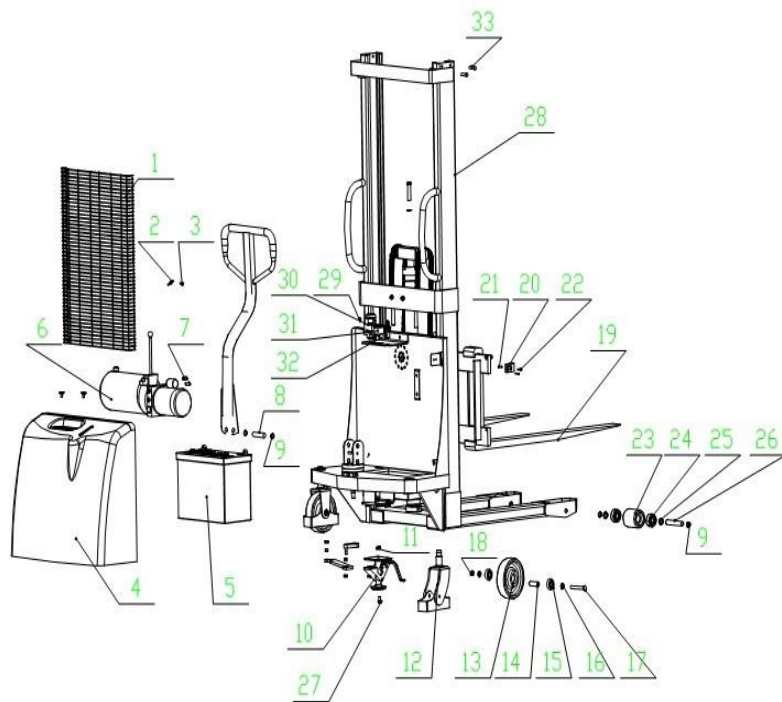

1.2. Hydro-cylinder assembly

| No. | Description | Material code | Qty. |
|-----|--|---------------|------|
| 1 | Enlarge mouth type pipe joint body M14*M14*39 | BDA-03021 | 1 |
| 2 | Combined seal washer Φ14 | T-DP-010 | 3 |
| 3 | Explosion-proof valve | BDA-03018 | 1 |
| 4 | Hydro-cylinder | BDA-03009 | 1 |
| 5 | Oil return pipe | BDA-00022 | 1 |
| 6 | Return opening connector M14*32 | BDA-00024 | 1 |
| 7 | Guide liner | BDA-03004 | 1 |
| 8 | UHS seal ring Φ40×50×6 | T-MF-003 | 1 |
| 9 | O-shape seal ring Φ50×3.55 | T-MF-002 | 1 |
| 10 | Composite liner SF-1 4030 | T-ZC-025 | 1 |
| 11 | Hood | BDA-03003 | 1 |
| 12 | DH dust-proof ring Φ40 | T-MF-001 | 1 |
| 13 | Piston rod | BDA-03010 | 1 |
| 14 | Lining | BDA-03011 | 1 |
| 15 | O-shape seal ring Φ23.6×3.55 | T-MF-004 | |
| 16 | Piston | BDA-03013 | 1 |
| 17 | Guide ring | BDA-03014 | 1 |
| 18 | UHS seal ring Φ45×56×7 | T-MF-005 | 1 |
| No. | Description | Stock code | Qty. |
| 19 | Half ring | BDA-03016 | 2 |
| 20 | Half ring cover | BDA-03017 | 1 |
| 21 | Circlip for shaft Φ30 | T-DQ-005 | 3 |
| 22 | Nonmetal inserts nut M10 | T-LM-004 | 2 |
| 23 | Hydro-cylinder embrace climb | BDA-00003 | 1 |
| 24 | Circlip for hole Φ62 | T-DQ-006 | 2 |
| 25 | Chain wheel | BDA-03032 | 2 |
| 26 | Deep groove ball bearing 60026 | T-ZC-004 | 2 |
| 27 | Hexagon socket head cap screws M16×95 | T-LD-011 | 1 |
| 28 | Flat washer 16 | T-DP-007 | 1 |
| 29 | Chain wheel | BDA-03031 | 1 |
| 30 | Plate-type wheel | T-QT-011 | 2 |
| 31 | Cotter Φ2*16 | T-XZ-002 | 6 |
| 32 | Chain shaft | BDA-03040 | 4 |
| 33 | Flatment stem | BDA-03041 | 2 |
| 34 | Flat washer Φ16 | T-DP-007 | 4 |
| 35 | Hexagon nut M16×1.5 | T-LM-008 | 1 |
| 36 | Short stem | BDA-03039 | 2 |

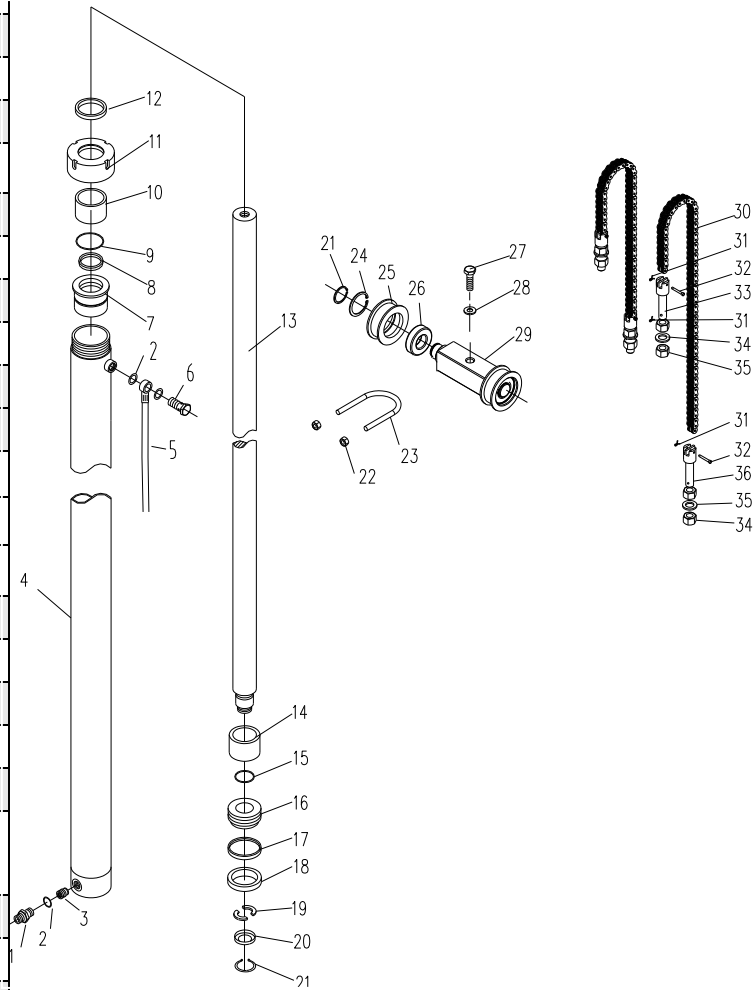

1.3. Fork assembly

| No. | Description | Material code | Qty. |
|-----|---|---------------|------|
| 1 | Lift table | SDA-07001 | 1 |
| 2 | Hexagon socket set screw with flat end M16×50 | T-LD-0 | |
| 3 | Circlip for hole Φ72 | T-DQ-0 | |
| 4 | Deep groove ball bearing 60207 | T-ZC-0 | |
| 5 | Roller Φ106×32 | BDA-0 | |
| 6 | Circlip for shaft Φ35 | T-DQ-0 | |
| 7 | Hexagon socket head cap screws M6*16 | T-LD-0 | |
| 8 | Steel ball φ19.05 | T-QT-0 | |
| 9 | Plate-type movable fork | BDA-0 | |

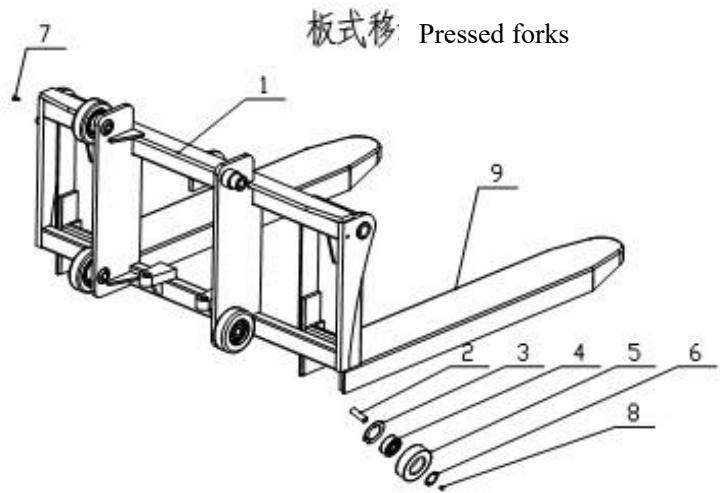

| No. | Description | Material code | Qty. |
|-----|---|---------------|------|
| 1 | Lift table | SDC-07001 | 1 |
| 2 | Hexagon socket set screw with flat point M16×50 | T-LD-004 | |
| 3 | Circlip for hole Φ72 | T-DQ-001 | |
| 4 | Deep groove ball bearing 60207 | T-ZC-001 | |
| 5 | Roller Φ106×32 | BDA-0600 | |
| 6 | Circlip for shaft Φ35 | T-DQ-002 | |
| 7 | Locknut M10 | T-LM-004 | |
| 8 | Hexnut M10 | T-LM-001 | |
| 9 | Hexagon bolt M10*45 | T-LD-013 | |
| 10 | Forging fork | SDC-07010 | |
| 11 | Steel ball φ19.05 | T-QT-010 | 4 |

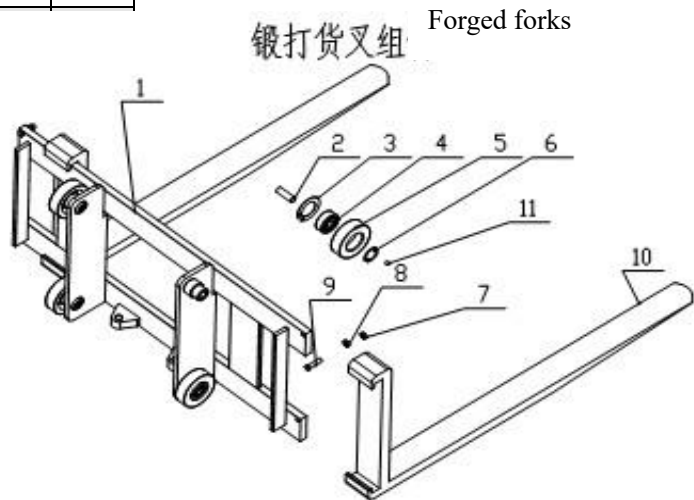

2. Hydrametic schematic diagram

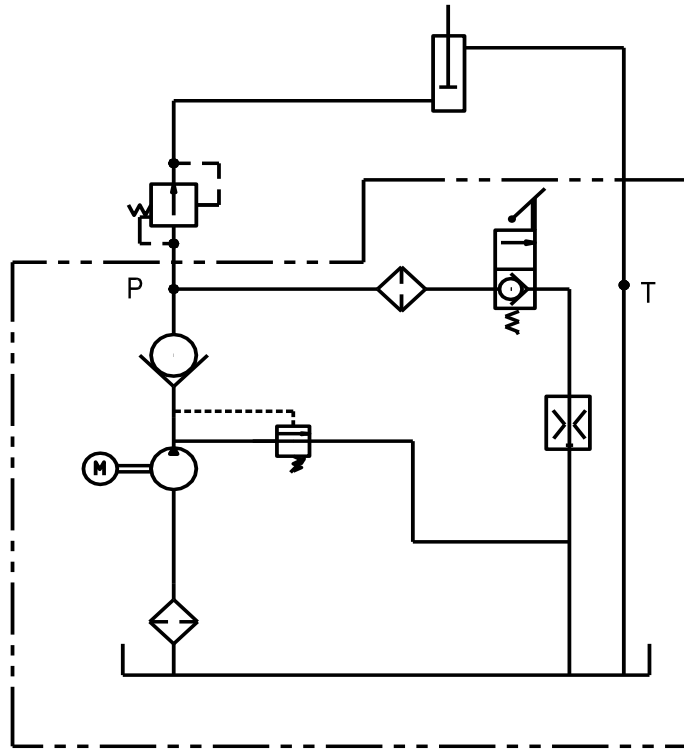

3. Electrical schematic diagram

