

# HAND PALLET TRUCK MODEL A25

## USER MANUAL

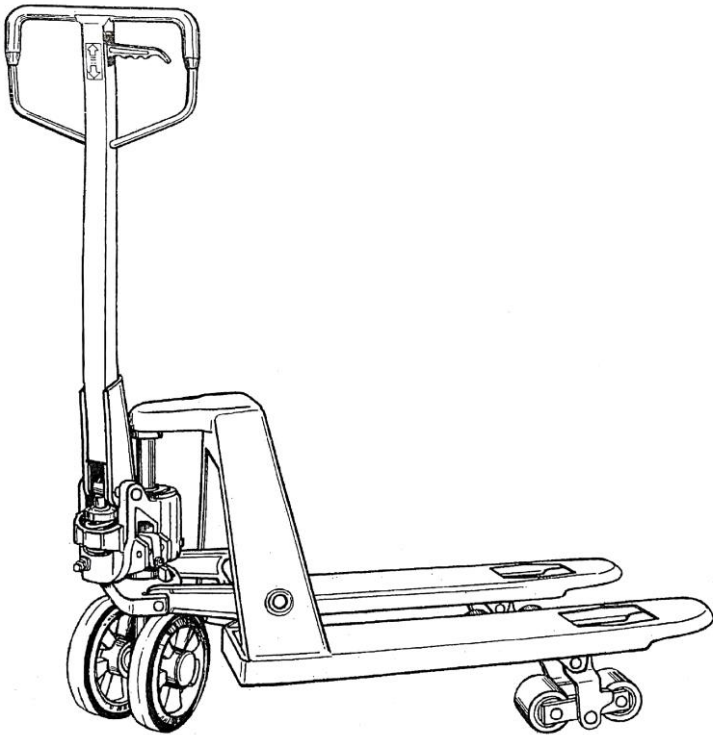

### **WARNING**

Do not use the truck before reading and understanding these operating instructions.

### **NOTE:**

- Please check the designation of your present type at the last page of this document as well as on the ID-plate.
- Keep for future reference.

# CONTENTS

Thanks for your choice and using the high quality hand pallet truck that we offer to you. It may be helpful if you can spare a little time to read this manual carefully before using. Keep the book well, and it'll be more convenient for the truck maintenance and the contact with us in future.

We have to inform you in advance that, for the products' continuous evolution and improvement, we may do some appropriate improvements in the design of products, and there's maybe something not consistent with the objects. Here we thanks for your understanding.

Both the product technology and safety requirements of this product conform to the national and international standard, please be at ease when using.

## OPERATION MANUAL

### 1 Application Range

This product is suitable for use in rated load.

This product is good for handling palletized cargo.

This product is suitable for the hard and flat ground.

This product is limited to single operation.

### 2 Main parameters

The specifications in table 1 is our standard truck's main technical parameters, if need more details, please get from our agents.

We also produce pallet truck with special specifications to meet all requirements, such as extra-low, ultrahigh, super-wide, ultra narrow, over-length, exceed short or with brake, please contact with our sales engineer.

**Table 1**

Rated Capacity (Lbs)		4400/5500/6600/7700/11000	
Main specifications	Distance between fork-arms	B (in)	20.5/21.5/27
	Fork length	L (in)	45.3/48
	Fork lowered height	H (in)	2.95/3.35
Overall dimensions	Length*width*height	(in)	(15+L)xBx48.8
Steering wheel diameter		(in)	Φ7.87/7.09/6.3
Fork wheel diameter		(in)	Φ3.15/2.91/2.76
Weight		(Lbs)	132~176.5

### 3 Assembly of hand pallet truck

For the transportation, the handle is disconnected with the complete machine when you get the

product, which requires yourself assembling it. If conditions allow, you can also authorize our retailer to assemble.

First please prepare some tools, such as: hammer, pliers, and so on.

1 Pull out the split cotter pin from the pin roll with three holes, and then extract the pin roll.

2 Move the hand grip into the pump place, and insert the pin roll back into the original place, then get the spring pins through the two end holes of the pin roll, and couple the hand grip and pump body. Here the two end spring pins of pin roll should be implanted into the slot of the layer board end face of the pump's both ends.

3 Pull down the hand grip, and remove the fixed pin from the big spring.

4 Put the chain of the hand grip get through the middle hole of pin roll. For the penetration convenient, you can pull the hand grip a little angle slightly, and this job needs a little patience.

5 Take the screw nut which is at the end of chain and hitch the groove of the lever board. Then unscrew the top nut slowly and leave a bit.

6 After finishing assembling according to the above steps, do more steps as below.

After the truck is assembled, try to rock the hand grip and operate different positions of control handle knob to examine the lifting, free position and dropping and check that whether the different positions are normal or not.

The screw under the lever board is used to adjust the truck situation. When the truck body drops immediately after it is lifted, you should turn the screw a little counter-clockwise. And then try the truck again until truck body could lift normally. If the truck body couldn't drop after it is lifted, you should turn the screw a little clockwise. And then try to operate truck again until the truck body could drop normally. The external hexagon nut at screw plays the locking function in the truck. So you should undo the external hexagon nut before adjustment. And screw down the nut after you finish the adjustment.

#### **4 Operation Guide**

See above fig., when hand knob 1 is placed on the lift position, the truck will be in a state of lift. At this time, if you rock the hand grip, the truck will be lifted.

When hand knob 2 is placed on the free position, the truck will travel. At this time, if you rock the hand grip, the truck will neither lift nor drop. Then, you can use the truck move the cargo.

When the hand knob 3 is placed on the drop position, truck forks will drop. At this time, the truck forks will drop automatically.

#### **5 Inspection before use**

If the hand pallet truck has not been used or placed upside down for a long time, air may get into the hydraulic system, the trouble can be eliminated by the following method:

Turn the hand knob to the drop position and rock the handle for 4-6 times. Then release the operation knob. If necessary, the process can be repeated for several times until the hand pallet truck can be operated normally.

First check the truck when it's unloaded, you should be sure that the lift and drop is normal, the wheel is without defect, rolling is not blocked, and sundries on the wheel axle is cleared up.

## 6 Loading type and rated weight

Ideal cargo should be pallet type, and the gravity center of the cargo is just in the middle of the truck forks. The rated weight must be reduced when the cargo gravity center is not in the middle of the truck forks. The rated weight is shown as the label.

When you choose a truck you should consider the rated load, and our suggestion is to buy one which the load capacity is 1.25 or 1.5 times of the actual use. Such the truck has rich quantity and it's safer to use for a long time.

## 7 Hydraulic oil

Working liquid of the pump meets ISO standard's #32 anti-wear hydraulic oil, and the needed capacity is about 250-300ml, which is according to the environment temperature  $-5\sim 40^{\circ}\text{C}$ . When the temperature is during  $-35\sim 5^{\circ}\text{C}$ , you choose the anti-wear hydraulic oil which is suitable for the low temperature environment, or declare when you order.

## 8 Maintenance

- 8.1 Although this truck is designed and manufactured as a non-maintenance one, its performance will better if we make some necessary maintenance.
- 8.2 The routine check should be carried out daily and every abnormal phenomenon should be dealt with immediately. Please do not use faulty truck in order to prolong the service life.
- 8.3 Add 1-2 drops of oil in the rotary joints every three months. Generally the refueling point is at the socket of shaft and hole.
- 8.4 Replace the wheel bearing every 6-12 months.
- 8.5 Make an adjustment of the connecting rod under the fork every 6-12 months, or as the truck performance.
- 8.6 Replace the hydraulic oil in the pump every 12 months. The amount of hydraulic oil should not be too much or too little, generally 250-300ml, and its oil level should not exceed a maximum height of the filling hole next to the pump.
- 8.7 Make an adjustment of the screw on the lever plate every 6-12 months or depending on the truck performance, and the adjustment method is the same as the relevant section of the above assembling content.
- 8.8 The wheel life should depend on the wear and tear case, you should replace the wheel which wears much or loss of round.
- 8.9 Specially pay more attention to the place between wheel and axis. Make sure there's not any yarn or other rags in order to keep all wheels running with handiness.

## 9 Possible faults and trouble shooting

Table 2 is the main faults of hand pallet truck and its solution, for your reference:

### Table 2

No.	Faults	Causes	Trouble shooting
1	The forks can't be lifted to the max. lift height.	hydraulic oil is not enough	Add appropriate filtrated working oil.
2	The forks can't return to the lowest position.	Too much hydraulic oil.	Take out appropriate working oil.
		Some parts are deformed or blocked.	Replace the parts or repair.
3	The forks can't drop after lifted.	The control valve is abnormal.	Readjust the unloading device.
		The parts are deformed or damaged.	replace the damaged and deformed parts.
4	Hydraulic oil leakage	The oil seal is unavailable.	Replace the oil seal
		The pump core and the surface of the plunger is damaged or worn.	Replace the core, plunger and the damaged parts
		The coupled places become loosend.	Fasten the loosened place again.
5	The fork can't be lifted.	The viscosity of the working oil is too high, or there's no working oil.	Check the hydraulic oil or replace it.
		There's impurity in the oil.	Clear up and add new working oil.
		The valve is abnormal.	Readjust the unloading device
6	The forks drop immediately after they are lifted; the handle returns or the forks drop markedly after they are lifted.	The valve of oil pump is blocked by abnormal matter.	Open the control valve and take out the parts. Then re-install the parts after they are cleaned.

## 10 Notes

- 10.1 Please read the operation instruction carefully before you operate the hand pallet truck and learn about all the features of this type of hand pallet truck.
- 10.2 If you want to let the truck down by controlling the hand knob, you should better lift the hand knob a little first, and then let the truck down slowly. It is forbidden to pull the hand knob with great force, because rapid dropping could cause some damages to both the hand pallet truck and cargo.
- 10.3 Don't rock the hand grip at a high speed and in a high frequency.
- 10.4 Don't load the cargo at a high speed.
- 10.5 Don't overload the forks. Overloading could keep the hand pallet truck from working normally.
- 10.6 The gravity center of cargo should be in the middle of truck forks. The offset of cargo could make hand pallet truck out of balance.
- 10.7 Don't load loose or unstable goods!
- 10.8 Don't put the goods on the truck fork for a long time.
- 10.9 When the truck does not work, make sure that the truck forks are on the lowest position.
- 10.10 It is forbidden to load people and let them stand on the forks to slide. Don't put any part of body below the cargo.
- 10.11 The truck is suitable for flat and hard ground to use. If you have to use on the sloping ground, you can choose the truck with brake van.
- 10.12 Do not operate the unnamed position.
- 10.13 Do not try to repair without training!

## 11 Transportation and storage

For the time not being in use, it should be stored in dry and well-ventilated room, without any corrosive environment.

The truck should be placed in level, and no weight on it for a long time.

Lubricate the joint hinge, and coat the anti-rust oil at the bare metal.

Repair the paint-off place timely!

Do not touch water, much less than being stored together with chemicals.

Product lifting and holding up, should be under the command of professionals.

The products should be fixed with carriage by rope in Long-distance transportation.

Pay attention to some parts of this product while moving or carrying, as that may wound human body.

## 12 Disposal of waste

When the truck is out of its service life or the waste parts replaced down, please don't pour out anywhere. In case of damaging the environment, here's the disposal suggestion for your reference:

- 12.1 First of all, disassemble the products, pour out the hydraulic oil, and the metal parts and rubber parts should be classified.
- 12.2 Collect the waste hydraulic oil, and send it to the oil recovery site or burn it in terms of national safety standards method.
- 12.3 More than 99% parts of this product are made of steel materials, which can be delivered to scrap metal recycling unit to disposal.
- 12.4 Only a few of rubber parts can also be sent to recycling site to process.

## BF Spare Parts List

### 1. Truck Frame

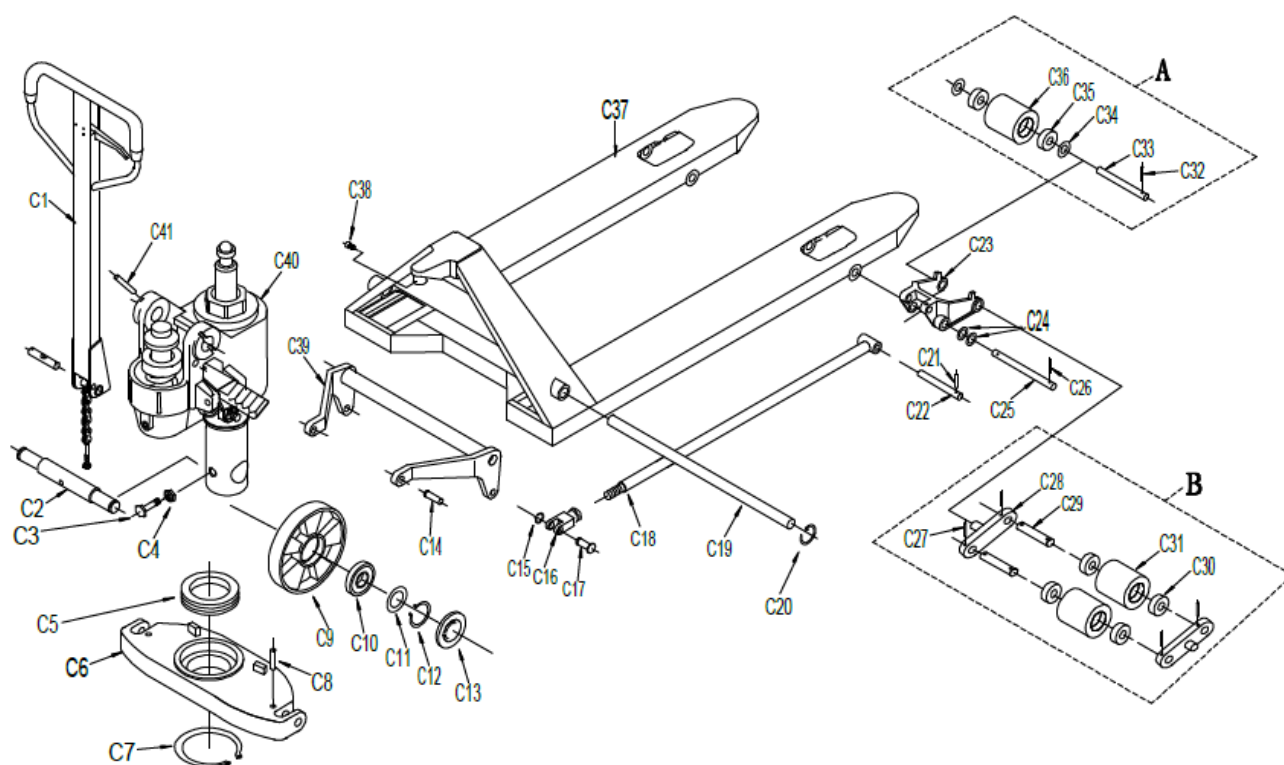



NO.	NAME	QTY	NO.	NAME	QTY	NO.	NAME	QTY	NO.	NAME	QTY
C51	SPRING PIN	2	C65	SPRING PIN	1	C79	STEEL BALL SEAT	1	C93	WASHER	1
C52	SPRING	1	C66	PRESS WHEEL	1	C80	SPRING	1	C94	BOLT	1
C53	SPRING PLATE	1	C67	BUSHING	1	C81	ADJUST SCREW	1	C95	U SEAL RING	1
C54	ROLLER	1	C68	BUSHING	1	C82	WASHER	1	C96	O SEAL RING	1
C55	SPRING PIN	1	C69	SPRING PIN	1	C83	SEAL SCREW PLUG	1	C97	CYLINDER CAP	1
C56	SPRING PIN	1	C70	SHAFT	1	C84	SPRING	1	C98	O SEAL RING	1
C57	SPRING PIN	1	C71	SCREW PLUG	1	C85	STRIKE PIN	1	C99	DUST RING	1
C58	HANDLE TUBE	1	C72	WASHER	1	C86	O RING	1	C100	PLUG	1
C59	PULL ROD	1	C73	SPRING	1	C87	WASHER	1	C101	STEEL BALL	1
C60	CHAIN	1	C74	VALVE SPOOL	1	C88	STRIKE PIN SLEEVE	1	C102	SMALL PLUG	1
C61	ADJUST BOLT	1	C75	VALVE BUSH	1	C89	ADJUST BOLT	1	C103	SPRING GAP	1
C62	LOCK NUT	1	C76	STEEL BALL	1	C90	SCREW	1	C104	STRAIGHT TAPPET	1
C63	HANDLE COVER	1	C77	PUMP	1	C91	LEVER PLATE	1	C105	DUST RING	1
C64	SHAFT	1	C78	STEEL BALL	1	C92	SPRING PIN	1	C106	U SEAL RING	1

## DF Spare Parts List

### DF TRUCK FRAME PARTS LIST

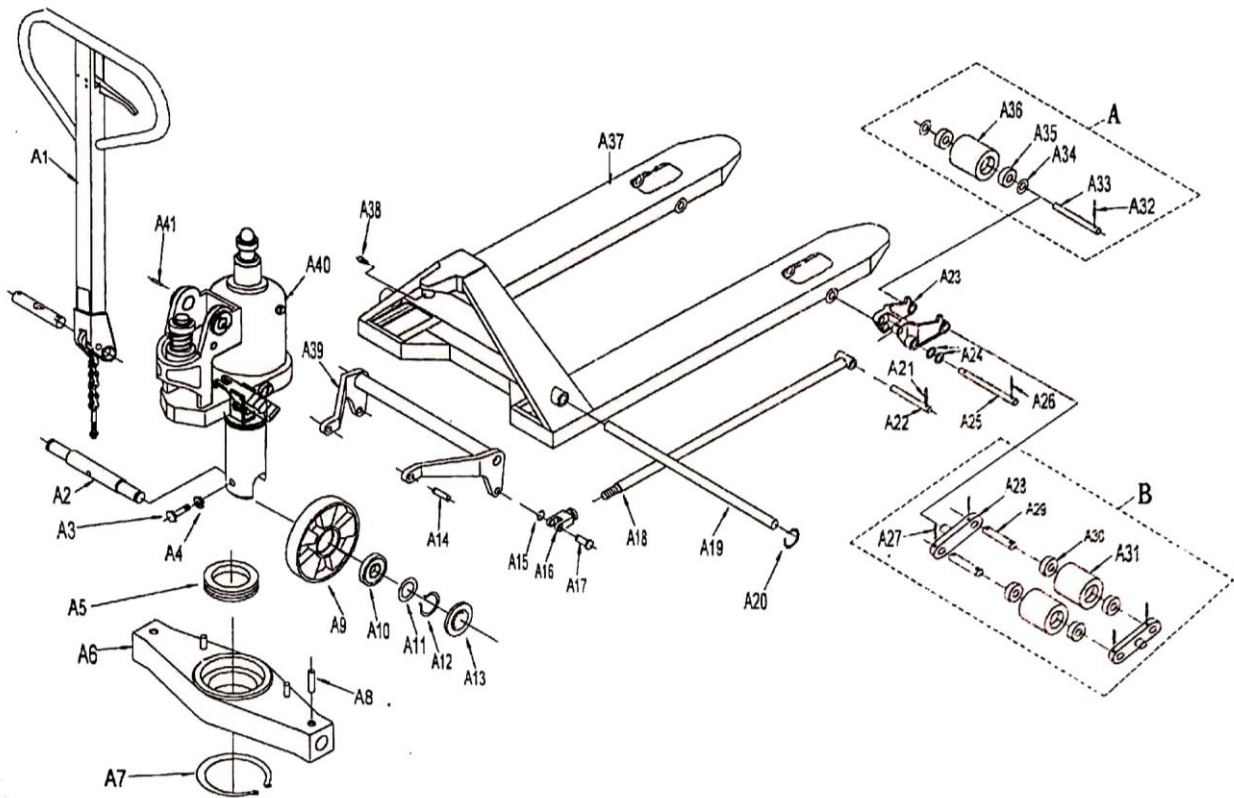

NO.	NAME	QTY	NO.	NAME	QTY	NO.	NAME	QTY
A1	HANDLE ASSEMBLY	1	A16	CONNECTION HEAD	2	A30	BEARING 6204	8
A2	WHEEL SHAFT	1	A17	PIN SHAFT	2	A31	FORK ROLLER	4
A3	BOLT	1	A18	CONNECTION ROD	2	A32	SPRING PIN	2
A4	LOCK NUT	1	A19	LONG SHAFT	2	A33	ROLLER SHAFT	2
A5	BEARING	1	A20	SNAP RING FOR HOLE	2	A34	WASHER	4
A6	SUPPORTING SEAT	1	A21	SPRING PIN	2	A35	BEARING 6204	4
A7	SPRING WASHER	1	A22	CONNECTION ROD SHAFT	2	A36	FORK ROLLER(SINLGE)	2
A8	SPRING PIN	1	A23	WHEEL FRAME	2	A37	TRUCK FRAME	1
A9	BIG WHEEL	2	A24	WASHER	4	A38	BOLT	2
A10	BEARING 6204	2	A25	SHAFT	2	A39	ROCKER ARM	1
A11	WAHSHER	2	A26	SPRING PIN	4	A40	HYDRAULIC PUMP	1
A12	SNAP RING	2	A27	SPRING PIN	8	A41	SPRING PIN	1
A13	DUST RING	2	A28	CONNECTION PLATE	4	A	FORK ROLLER ASSEMBLY(SINGLE)	1
A14	PIN	2	A29	ROLLER SHAFT	4	B	FORK ROLLER ASSEMBLY(DOUBLE)	1
A15	SNAP RING	2						

## DF PUMP PARTS LIST

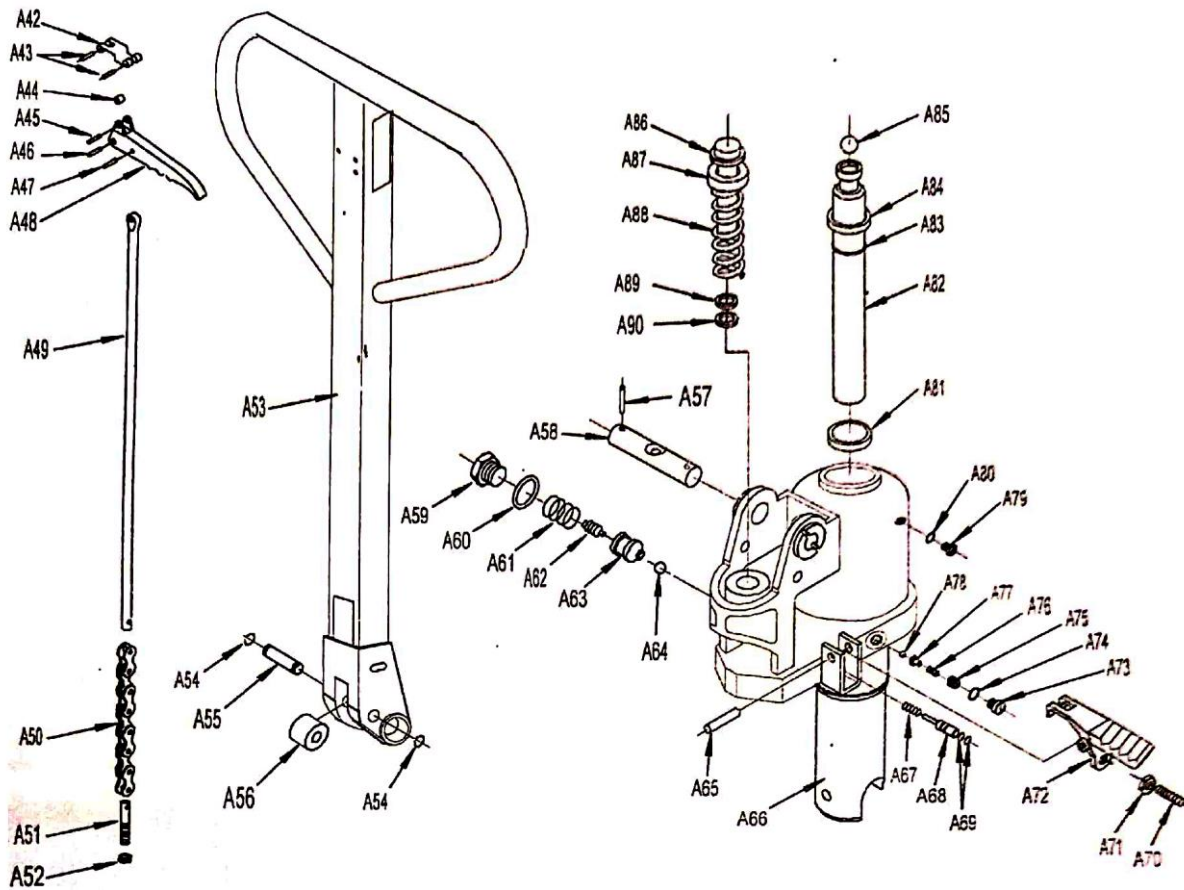

NO.	NAME	QTY	NO.	NAME	QTY	NO.	NAME	QTY	NO.	NAME	QTY
A42	SPRING PLATE	1	A54	AXLE RING	1	A66	PUMP	1	A78	STEEL BALL	1
A43	SPRING PIN	2	A55	SHAFT	1	A67	SPRING	1	A79	SEAL SCREW	1
A44	SMALL ROLLER	1	A56	ROLLER	1	A68	STRIKE PIN	1	A80	WASHER	1
A45	SPRING PIN	1	A57	SPRING PIN	1	A69	O RING	1	A81	U RING	1
A46	SPRING PIN	1	A58	HOLE SHAFT	1	A70	ADJUST BOLT	1	A82	BIG PISTON	1
A47	SPRING PIN	1	A59	SEAL SCREW	1	A71	NUT	1	A83	O RING	1
A48	HANDLE KNOB	1	A60	WASHER	1	A72	LEVER PLATE	1	A84	DUST RING	1
A49	PULL ROD	1	A61	SPRING PIN	1	A73	SEAL SCREW	1	A85	STEEL BALL	1
A50	CHAIN	1	A62	SPOOL	1	A74	WASHER	1	A86	SMALL PISTON	1
A51	ADJUST NUT	1	A63	VALVE BUSH	1	A75	ADJUST SCREW	1	A87	SPRING COVER	1
A52	LOCK NUT	1	A64	STEEL BALL	1	A76	SPRING	1	A88	BIG SPRING	1
A53	HANDLE TUBE	1	A65	SPRING PIN	1	A77	STEEL BALL SEAT	1	A89	DUST RING	1
									A90	U RING	1

# DB Spare Parts List

## 1. DB TRUCK FRAME PARTS LIST

NO.	NAME	QTY	NO.	NAME	QTY	NO.	NAME	QTY	NO.	NAME	QTY
B1	HANDLE ASSEMBLY	1	B12	AXLE RING	2	B23	WHEEL FRAME SHAFT	2	B34	SINGLE FRONT WHEEL	2
B2	WHEEL SHAFT	1	B13	DUST VOER	2	B24	SPRING PIN	2	B35	TRUCK FRAME	1
B3	BEARING WASHER	1	B14	PIN	2	B25	SPRING PIN	8	B36	BOLT	2
B4	BEARING	1	B15	SHAFT RING	4	B26	WHEEL PLATE	4	B37	ROCK ARM	1
B5	SUPPORT BASE	1	B16	SHAFT	2	B27	TANDEM SHAFT	4	B38	PUMP	1
B6	AXLE RING	1	B17	PUSH ROD	2	B28	BEARING 6204	8	B39	SPRING PIN	1
B7	SPRING PIN	1	B18	LONG SHAFT	2	B29	TANDEM FRONT WHEEL	4	A	SINGLE WHEEL ASSEMBLY	1
B8	WASHER	2	B19	HOLE RING	2	B30	SPRING PIN	2	B	TANDEM WHEEL ASSEMBLY	1
B9	STEER WHEEL	2	B20	AXLE RING	4	B31	SINGLE SHAFT	2			1
B10	BEARING 6204	2	B21	PUSH SHAFT ROD	2	B32	WASHER	4			1
B11	WASHER	2	B22	WHEEL FRAME	2	B33	BEARING 6204	4			1

## 2. DB HYDRAULIC PUMP

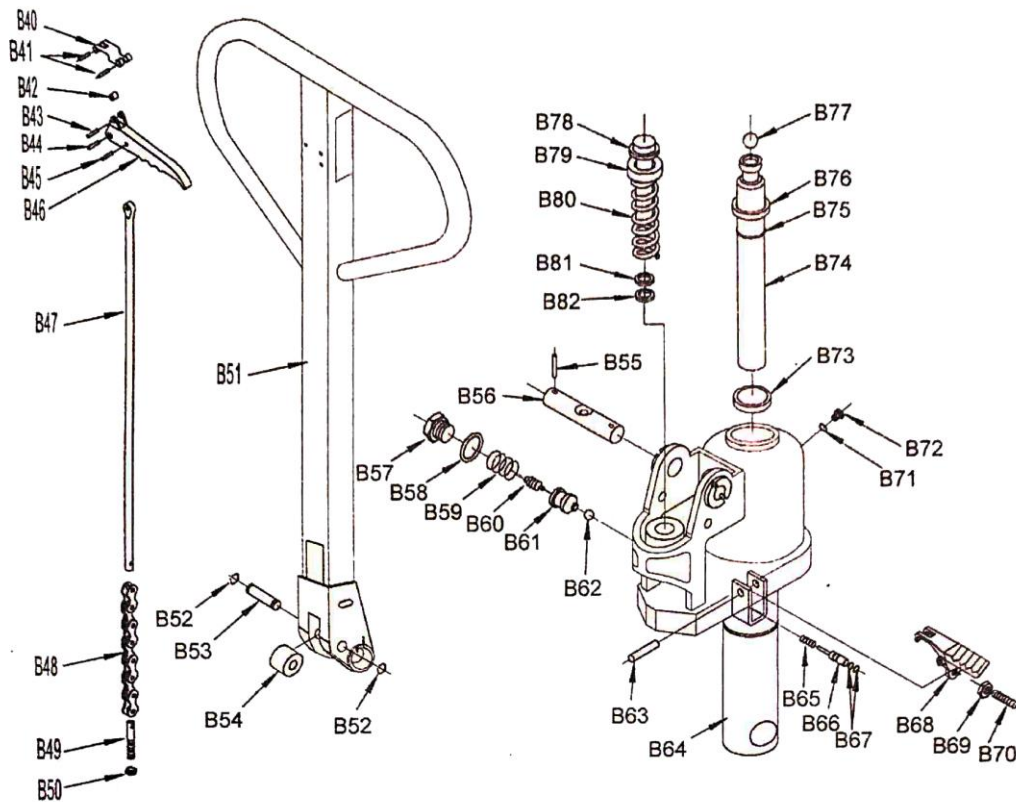

NO.	NAME	QTY	NO.	NAME	QTY	NO.	NAME	QTY	NO.	NAME	QTY
B40	SPRING PLATE	1	B51	HANDLE TUBE	1	B62	STEEL BALL	1	B73	U RING	1
B41	SPRING PIN	2	B52	AXLE RING	1	B63	SPRING PIN	1	B74	PISTON	1
B42	SMALL ROLLER	1	B53	SHAFT	1	B64	PUMP	1	B75	O RING	1
B43	SPRING PIN	1	B54	ROLLER	1	B65	SPRING	1	B76	U RING	1
B44	SPRING PIN	1	B55	SPRING PIN	1	B66	STRIKE PIN	1	B77	STEEL BALL	1
B45	SPRING PIN	1	B56	HOLE SHAFT	1	B67	O RING	1	B78	SMALL PISTON	1
B46	HANDLE KNOB	1	B57	SEAL SCREW	1	B68	LEVER PLATE	1	B79	SPRING COVER	1
B47	PULL ROD	1	B58	WASHER	1	B69	NUT	1	B80	BIG SPRING	1
B48	CHAIN	1	B59	SPRING PIN	1	B70	ADJUST BOLT	1	B81	DUST RING	1
B49	ADJUST NUT	1	B60	SPOOL	1	B71	WASHER	1	B82	U RING	1
B50	LOCK NUT	1	B61	VALVE BUSH	1	B72	SEAL SCREW	1			1