

Operations & Maintenance Manual

Moving Mast Walkie Stacker

EH15T/EH15TH



Instructions for use

Please read this manual carefully and operate the vehicle safety.

- Do not operate this vehicle without training.
- Please comply with ISO3691 “Safety Specification for Motor Vehicles Industry”.
- Please do not modify or change the repair parameters, including adjusting the pressure. Any loss or damage to the vehicle resulting from such actions will be your responsibility, and doing so will void our warranty commitment.

SPECIAL WARNING:



The company is committed to innovation and sustainable development. As part of this commitment, we continually improve the technology of our products. Therefore, we reserve the right to make changes and improvements to any product described in this specification without prior notice.

Introduction

Welcome to the use of this series of forklift trucks. The operation manual provides important information to help you fully understand and master the safe operation of the vehicles.

The manual outlines the specific differences between various forklift models in detail. During operation and maintenance, it's essential to focus on the information that is relevant to the model of forklift truck being used.

Safety instructions and important precautions are identified by the following ICONS:

1.  --- Refers to the safety instructions that must be followed before use to prevent harm to people.
2.  --- Refers to the precautions that must be followed before use to prevent damage to the equipment.
3.  ---Refers to the general precautions and instructions before use.

 Most of this product is made of recyclable steel, and the waste generated in the process of use, maintenance, cleaning and disassembly must be recycled and disposed of pollution-free in accordance with local regulations. The recycling of these wastes must be done by professionals in designated areas, such as hydraulic oil, batteries and electronic equipment waste disposal, if not properly, can cause harm to the environment and human health.

 For continuous product improvement, manufacturers reserve the right to change their own product design and specifications without prior notice. If you want to know the latest product parameters, please contact us. Note: All parameters here are based on the date of publication.

1. Safety operation rules

- 1.1 Driver requirements: The lift truck must be operated by a person who has been trained in the operation of the lift truck, and the training can demonstrate the operation of moving and manipulating the cargo and can clearly instruct the user how to operate the lift truck.
- 1.2 Rights, obligations and responsibilities of the driver: The driver must be clear about his rights and obligations and have been trained in the operation of the forklift truck; Be familiar with the contents of the operating instructions. If the forklift is pedestrian controlled, the driver must also wear safety boots when operating.
- 1.3 Prohibition of Unauthorized use: The driver is responsible for the forklift during the working period and must prevent unauthorized persons from driving or operating the forklift.
- 1.4 Faults and defects: When the forklift fails or defects occur, the management personnel must be notified immediately. If the forklift cannot be operated safely (e.g., wheel wear or brake failure), stop using it until it has been completely repaired.
- 1.5 Safe operation and environmental protection
 - a. Check and maintenance Operations The contents of this chapter must follow the interval specified in the maintenance list.
 - b. The parts of the forklift, especially the safety device, shall not be changed without permission, and the operating speed of the vehicle shall not be allowed to change.
 - c. All spare parts of the original factory have been verified by the quality department. To ensure the safety and reliability of the forklift operation, only spare parts of the manufacturer must be used. Replacement parts such as oil and fuel must be disposed of in accordance with the appropriate environmental protection regulations.
- 1.6 Hazardous areas: Hazardous areas are generally defined as areas where the forklift or its load lifting devices (such as forks or accessories) pose a hazard to people during operation or lifting, or where loads are being transported. Usually, this range extends to the area where loads or vehicle accessories land.



Unauthorized personnel must ask him to leave the danger area. As long as there may be some kind of injury to the personnel, the driver must give a warning, if the driver has asked it to leave but has not left the dangerous area, must immediately stop the forklift.



The use of this vehicle poses a risk of crushing or shearing to personnel.

- 1.7 High-risk environment: The vehicle shall be operated, used and maintained according to the information in this manual. Any other use not listed that may result in damage to people, vehicles or property. First, avoid overload or unbalanced loads. It is important to ensure that the load limit is not exceeded. The

maximum load is indicated on the nameplate. Forklifts may not be used in corrosive or very dirty areas and may cause explosions in flammable environments.



The car is not specifically designed for high-risk environments.

1.8 Safety devices and warning signs: Safety devices, warning signs and warning precautions described in the front of the operating instructions must be given sufficient attention.

1.9 Driving in Public places: The car is prohibited from driving in public places except special areas.

1.10 Distance between vehicles: Please keep in mind that the vehicle in front of you may suddenly stop at any time, so please maintain an appropriate distance.

1.11 Passengers: Carrying or lifting personnel is strictly prohibited.

1.12 Headroom height: The vehicle is prohibited from use in the environment where the headroom height is lower than the cargo or door frame.

1.13 The use of elevators and the operation of loading platforms: Elevators and loading platforms can be used for vehicle transportation if there is sufficient carrying capacity, without affecting the operation of the vehicle, and with the consent of the user of the vehicle. The driver of the vehicle must personally confirm before entering the elevator or loading platform. When the vehicle enters the elevator, it must place the goods in front and occupy a proper position so that it does not touch the walls around the elevator. When taking the elevator with the vehicle, the personnel must enter the vehicle safely and stop before entering, and the personnel must leave before the vehicle when leaving.

1.14 Driving channel and working area: The vehicle must be driven on the specially designated channel, non-relevant personnel must leave the working area, and the cargo should be stacked in the designated place.

1.15 Operation management: The driving speed must be appropriate to the local conditions. The vehicle must travel slowly through curves, narrow passages, swing gates and in unobstructed areas. The driver must be able to visually detect a sufficient braking distance between the forklift truck and the vehicle in front, and he must always be in control of his vehicle. Sudden stopping (unless necessary in an emergency), rapid reverse turning, and chasing each other are not allowed in areas with poor access. Do not lean out to operate the vehicle.

- 1.16 Visibility: The driver must keep an eye on the direction of travel to ensure that the road conditions ahead are clearly visible. When the truck is moving backwards, the load obstructs the view, and a second person must walk in front of the truck to give corresponding guidance and warning.
- 1.17 Through ramps: only known ramps shall be allowed to pass, and the ramps shall be clean, non-slip, and the technical specifications for vehicles permit the passage of this ramp. The heavy load on the fork must face downhill. It is not permitted to turn around, walk sideways or park on the ramp. You must drive slowly through ramps, and you must be prepared to brake at any time.
- 1.18 Load on the ground: Please pay attention to check whether the weight of the body and load or the pressure of the wheel on the ground exceeds the bearing capacity of the ground when the vehicle is working.
- 1.19 Transportation: In the case of goods blocking the line of sight, it is best to drive on the opposite side of the cargo fork to obtain a good view and maneuverability. Driving with the fork forward can lead to unpredictable maneuverability problems.
- 1.20 Speed: Choose the right driving speed according to the ground conditions, visibility and follow the principle of optional operation. During the operation, it is forbidden to suddenly accelerate, stop and turn, which may lead to the overturning of the goods and the vehicle body.
- 1.21 Driving on the loading platform or approach bridge: Before driving this vehicle to the loading platform or approaching bridge of another truck, please check the maximum load of the approach bridge and must have a device to prevent the approach bridge from sliding. The driver must also check the maximum load of the truck and must also have a device to prevent the truck from moving.
- 1.22 Safe parking: Pay attention to safety when parking. Never Park your vehicle on a slope or hill. After parking, the fork must be completely lowered to the lowest position, and to avoid unauthorized personnel operating the vehicle, the electric lock switch must be turned off and the key removed.



If the car will not be used for a long period of time before recharging, be sure to disconnect the battery cable.

1.23 Signaling: The vehicle horn can be used to issue warning signals.

1.24 Labor protection shoes: In accordance with the EU standard EN-345:1-S1 technical standard, when working on the vehicle, you must wear protective shoes that meet the standard.

1.25 Vehicle alterations: Any alterations or alterations that may affect the load rating, stability or safe operation of the vehicle shall be subject to prior written approval from the vehicle's manufacturer or its replacement. Nameplates, tags, identification marks, operation and maintenance manuals must be changed accordingly after the vehicle manufacturer has approved of the changes.

If the vehicle manufacturer no longer exists and there is no replacement, the steps for the user to change the vehicle are as follows:

- a. Arrange for an industrial vehicle and their safety expert to design, test and complete changes or alterations.
- b. There is a permanent record of the design, testing and completion of the change or alteration.
- c. Load rating labels, patterns, labels, operation and maintenance manuals shall be changed accordingly.
- d. Attach a permanent, visible sign to the vehicle indicating changes to the vehicle or its location, time of change, person or organization.



Failure to follow these instructions will result in loss of warranty for damage to the vehicle. This also applies to the illegal export of products by customers or third parties without the permission of the manufacturer.

2. Technical manual

2.1 Technical parameter

Type number	EH15TH	EH20TH
Rated load capacity Q (lbs)	3300	4400
Load center distance c (in)	20	20
Lifting height (in)	118	118
No load speed (mph)	3.23	3.23
Full load travel speed (mph)	2.80	2.80
Full load climbing capacity (%)	6	6
Forward distance L1 (in)	23.03	23.03
Driving wheel size (in)	9.84x2.95	9.84x2.95
Drive motor power (kw)	1.5	1.5
Increase motor power (kw)	4.5	4.5
Driver's ear noise level According to EN12053 dB(A)	69	69

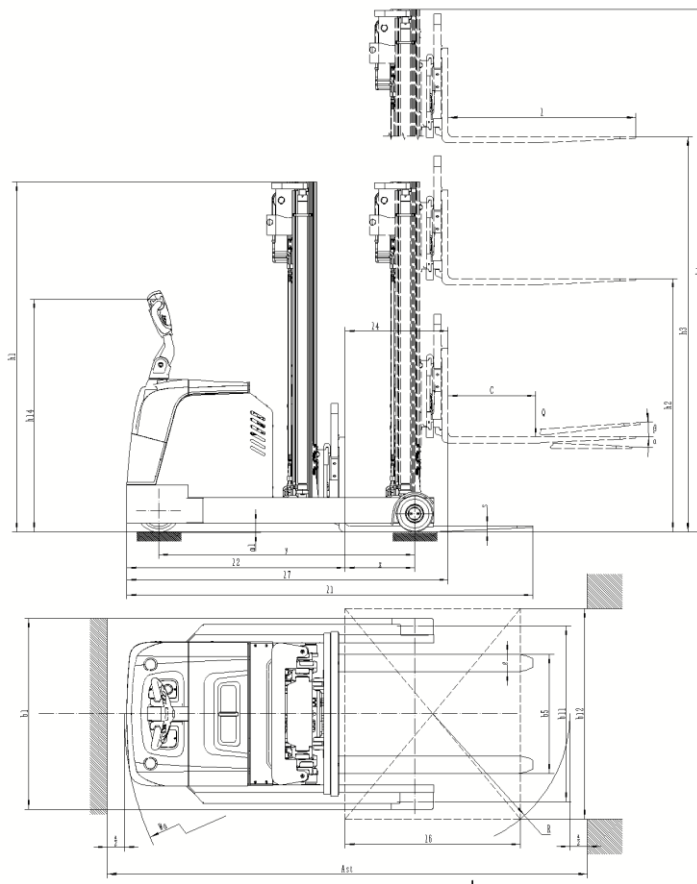

	EH15TH	EH20TH
H3	118	118
L	91.34	91.34
Wa	65.35	65.35
B1	42.91	42.91



This table provides only the technical parameters of standard vehicles. Non-standard vehicle technical parameters may not be the same as the table above. We reserve the right to update the technical parameters of this vehicle.

2.2 Technical Standards

According to ISO4871, the continuous noise level should be $< 70\text{dB(A)}$.

- The sustained noise level is measured at the operator's ear, as measured by the standard average during driving, lifting and standby.

Electromagnetic Compatibility (EMC)

The manufacturer confirms that the vehicle meets the limits for electromagnetic radiation and electromagnetic interference set by EN12895 and other relevant standards and has also carried out electrostatic discharge tests.

- Parts of the electrical system may be modified only with the written consent of the manufacturer.

2.3 Use and conditions of use

EH15TH-type forward lift truck uses battery as power source, AC motor as power, and drives the vehicle through gear transmission. The lifting of the fork relies on DC motor and hydraulic transmission to push the cylinder to lift the fork. Since the walking and lifting of the car are electric, it has the characteristics of labor saving, high efficiency, smooth operation of the goods, simple operation, safe and reliable, low noise, no pollution and so on. This series of forklifts is suitable for high strength short and medium range flat road transportation.

Use environment:

- a. The altitude does not exceed 6,562 feet.
- b. Ambient air temperature shall not exceed $+104^{\circ}\text{F}$, not lower than -13°F .
- c. When the ambient temperature is $+104^{\circ}\text{F}$, the relative humidity is not more than 50%, and some special treatment must be used at lower temperatures.
- d. Hard, flat ground.
- e. It is prohibited to use the car in flammable and explosive or acid and alkali corrosive environment.
- f. If the vehicle has quality problems or needs to order spare parts, please indicate the vehicle serial number and part number.

2.4 Test run



The vehicle can only use the battery as power, changing to AC will damage the electrical line, and the cable length connecting the battery should be less than 6 meters.

For the vehicle to work properly after delivery or transport, the following must be done:

- Before use, ensure that the plates on the vehicle are present and clearly visible. Otherwise, it should be replaced immediately.
- Check that all parts of the vehicle are complete and meet the requirements.



- Inspect the vehicle for defects and faults (especially wheels and lifting accessories).

- If necessary, install batteries without damaging battery cables.
- Charge the battery immediately.

If the customer wants to replace the battery with a new one, they should check whether the battery meter model matches the battery (or get permission from the manufacturer's after-sales service staff).

2.5 Vehicle towing without driving function

When the driving function of the vehicle does not work and the vehicle needs to be moved, the electromagnetic brake needs to be loosened before it can be moved.

- Press the SCram control switch and leave the power switch key in the "OFF" position.
- Open the cover.
- Loosen the 3 screws on the drive motor counterclockwise until the brakes do not impede vehicle movement.

Now, you can tow the vehicle.

- After towing to the destination, the vehicle should be recovered.



This operation should not be carried out on inclined roads and slopes.

3. Use and operation

3.1 Operation diagram

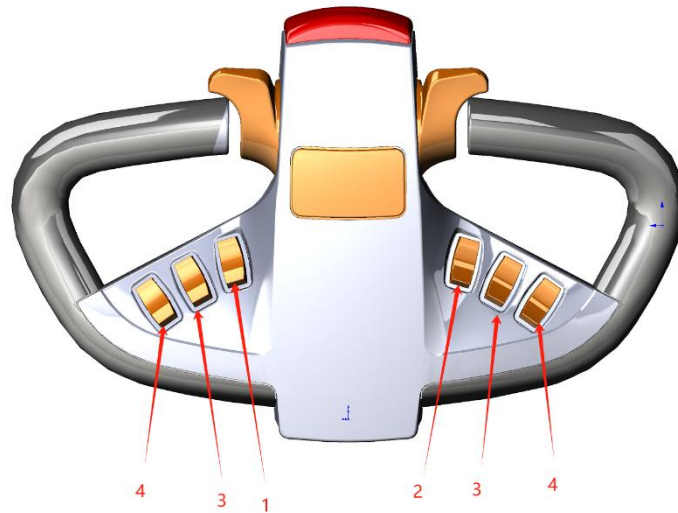

1. Lift button switch: control fork lift and fall
2. Push button switch: control the front and back movement of the door frame and fork
3. Tilt button switch: control fork forward tilt back
4. Side shift button switch: control fork left and right movement

3.2 Starting the Vehicle

The driver must verify that there are no people in the hazardous area of the vehicle before starting and operating the vehicle or lifting heavy objects.



In rain, snow, fog and windy weather, the use of vehicles will have a certain risk, if you want to use, you should evaluate its safety in advance.

Daily pre-start-up checks

Starting vehicle

- Turn on the emergency stop switch.
 - Insert the key into the electric lock switch and turn it to the right to position 1.
 - The meter displays the current power level.
 - Check whether the horn function is normal.
 - Check whether the brake function of the control handle is normal.
- Now the vehicle is ready to start.

3.3 Operation of the stacker

3.3.1 Starting, driving and stopping operations



Be very careful when starting and driving, especially when the human body part protrudes the outline of the vehicle.

No other person may be on board the vehicle while it is being driven.

Emergency stop

Hit the emergency switch which will cut off all electrical controls.

Forced braking

When the control lever is released, the vehicle brakes automatically (emergency stop). The control handle will automatically enter the above brake range (B1).

If the control handles slowly into the brake range, then be sure to find out the cause and rule out, if necessary, must replace the handle gas spring.

Start

- Only start when the battery box cover is closed and reliable.
 - Starting vehicle
- Travel speed is controlled by a controller.

- Rotate the control handle to the drive range "F", adjust the control handle to the desired direction, and the vehicle will move in the selected direction.

steer

-Swing the control lever left or right to drive.

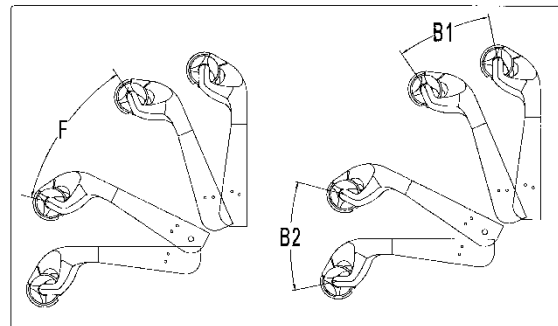

When the operator is facing the direction of travel of the vehicle and the load is behind the direction of travel of the vehicle, make the vehicle turn clockwise by simply turning the steering handle clockwise.

When the vehicle runs into obstacles, the force used to operate the rotating arm at this time should be smaller than the operating force when the vehicle is running under normal conditions. In this case, carefully turn the steering wheel/steering arm so that the vehicle carefully moves forward and backward to try to get the vehicle out of the obstacle and then proceed.

Driving on the slopes



When transporting goods on a slope, the goods always point upwards.

Take safety measures in the direction of downward rolling of the vehicle: when the control knob is set to the "0" position, quickly push down the handle backwards, and the driver releases the handle as needed to make the electromagnetic brake automatically act to control the speed of the vehicle and the direction of operation

(when the driver finds the stacker rolling downhill).

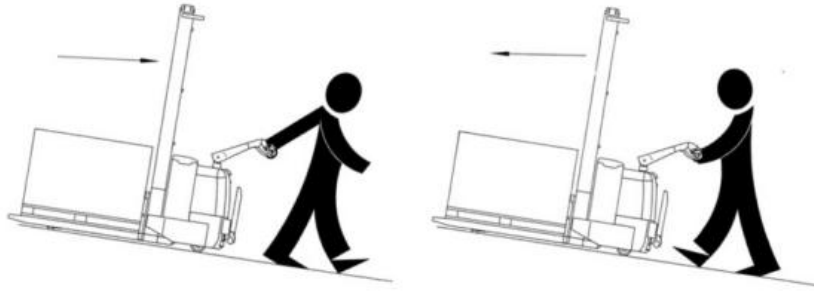

When the vehicle overturned, the operator should leave the vehicle in time.

Brake

The braking performance of the vehicle depends on the ground conditions. Drivers must be clear about this. There are three ways of braking a vehicle:

- With electromagnetic brake (control lever)
- Reverse current brake (controller)
- Brake with sensor (release brake)

Rely on electromagnetic brakes to brake

- By turning the control handle up or down to the brake range (B1) and (B2), the drive motor is mechanically braked.
- When the control handle is released, it automatically rotates to the above brake range (B1).
- When the vehicle stops, the electromagnetic brake acts as a parking brake.

Rely on the reverse current brake to brake



If the control system or drive power fails, then reverse current braking is possible.

- Turn the forward/backward knob in the opposite direction of travel until the vehicle stops.
- Release the forward/back knob.

Rely on inertia to brake

- After the forward/backward knob is released, the knob returns to the position and brakes through the inertia of the motor.



- The ratio of deceleration depends on the position of the knob.
- If the inertial brake is removed by the maintenance personnel and the forward/backward knob is set to the "0" position, it can only use electromagnetic brakes and reverse current brakes to brake.

3.3.2 Operation of lifting and lowering goods



Before lifting the goods, the driver must check that the goods are completely placed on the pallet and that the weight of the goods does not exceed the load capacity of the vehicle. It is not allowed to transport goods at full capacity for a long time.

- The fork should extend as far as possible under the cargo.
- When the "up" or "down" button is operated, it will rise or fall at a fixed rate.

Fork lift

- Press the control key "lift switch" to lift the cargo off the ground.

Fork drop

- Press the control key "drop switch" to lower the cargo to the ground.

Safe stop



Parking should pay attention to safety, must not park the vehicle on the slope or slope, after parking the fork must be completely reduced to the lowest position.

- Lower the fork.
- Turn the electric lock switch "1" to "0" and remove the key.

3.4 Adjustment of brake clearance:

- ① hollow screw
- ② connecting screw
- ③ spring
- ④ armature
- ⑤ motor shaft
- ⑥ spline sleeve
- ⑦ Friction plate
- ⑧ electromagnetic coil
- ⑨ Install cover plate
- ⑩ Install screws

The structure of the brake is shown in the figure. After the car is used for a period of time, the braking performance of the brake will decrease with the wear of the brake disc, or the brake disc cannot be released when it is locked, so the brake gap needs to be adjusted. As shown in the figure, in the braking state, first check the gap between the brake disc and the magnetic steel with a gauge, if the gap is greater than 0.5mm, it is necessary to adjust the gap, and the dirt and dust on the friction disc should be cleaned before adjustment. When adjusting, first loosen the connection screw 2, then adjust the length of the adjusting screw 1, and then tighten the fastening screw. After adjustment, the gap between the brake disc and the magnetic steel should be between 0.2-0.3mm. When adjusting, pay attention to the balanced adjustment of the three adjusting screws, so that the gap between the brake disc and the magnetic steel is uniform around the adjustment. After adjustment, switch on the brake with 24V DC power supply, you should be able to hear the crisp sound of the brake.

4. Battery maintenance, charging and replacement

4.1 Safe operating rules for lead-acid batteries

Before performing any operation on the battery, ensure that the vehicle is parked and in a safe position.

4.1.1 Maintenance Personnel

Battery charging, maintenance, and replacement must be operated by qualified professionals. Read the instructions carefully before preparing for operation, including the operation manual, supply preparation, and charging requirements.

4.1.2 Fire protection measures

Do not smoke or open flame when operating the battery. Storage batteries and charging must be away from flammable materials, at least 2 meters away, storage batteries must be well ventilated and equipped with fire facilities.

4.1.3 Battery Maintenance

1. The nut on each cell battery must be kept dry and clean, and each terminal and cable end must be tightened and coated with clean grease with a brush to prevent corrosion. The exposed terminals and terminals of the battery must be covered with a non-slip insulation cover.
2. The cables of each two cell batteries should be in good contact. Check the nuts of each pole for loose or slipping teeth, and once they appear, they must be tightened.
3. Keep the battery surface clean and dry. After charging is complete, apply cotton yarn or brush to clean up the acid stains, and use a damp towel if necessary.
4. The battery should avoid overcharging and over discharging, and fast charging and undercharging should also be prohibited. Otherwise, battery life may be affected.
5. Conductive objects are prohibited from being placed on the battery (including metal tools), otherwise it may cause the battery to short circuit or even explode.
6. Prohibit any harmful liquid or solid substances from splashing onto the surface of the battery. When using a densitometer or temperature meter, its surface should be clean, and no impurities should be allowed.
7. The discharged battery should be charged in time, delay time may damage the battery, cannot be delayed for 24 hours. In very cold weather, the battery placed outside may not be charged, at this time it should be moved indoors for charging.
8. If the battery is not used for a long time, it should be charged once every month, and it should be full every time.
9. In the process of charging or use, due to the evaporation of water, the electrolyte level is low, the application of purified water. Electrolytes with a specific gravity of 1.280 is not allowed.

10. When an individual battery unit fails, the cause of the failure and the faulty unit should be quickly identified and repaired and replaced if it cannot be repaired.
11. When charging, there should be adequate ventilation equipment, and smoking and open flames are strictly prohibited on site to avoid the danger of hydrogen explosion.
12. The electrolyte in the battery is toxic and corrosive, for this reason, regardless of the operation under any circumstances, you must wear good work clothes and protective mirrors to avoid body contact with the electrolyte in the battery.
13. If clothes, skin or eyes once stained with acid in the battery, immediately rinse with a large amount of water; When the skin or eyes are stained with acid, in addition to immediately rinse with a large amount of water, you must immediately go to the hospital for examination. The spilled acid must be neutralized immediately.
14. The weight and size of the battery have a considerable impact on the stability of the vehicle, so it is only permissible to change the model of the battery with the consent of the manufacturer.
15. It is strictly prohibited to discharge large current, such as driving and lifting at the same time.



To ensure safe operation, the vehicle must be equipped with a battery shield before use.

4.1.4 Disposal of waste batteries

Scrapped batteries must be recycled in accordance with the relevant laws and regulations of the region, stored in the specified environmental protection area or the specified waste disposal area, and this work must be carried out by qualified professional companies.

4.2 Battery Specifications

The weight and size of the battery can be found on the battery's nameplate.



The non-insulated terminals of the battery must be protected by an insulating cover. When the battery is connected and connected to the socket, the vehicle must be in the off state and the switch must be in the off position. When replacing or assembling a battery, ensure that the battery is securely secured in the battery box.

4.3 Storage, Transportation and Installation of batteries

The vehicle must be stopped on a level ground. To avoid short circuit, the exposed terminals and terminals of the battery must be covered with insulation covers. When the battery is pulled out, the connectors and cables of the removed battery must be properly placed. They must not obstruct the entry and exit of the battery.

When handling batteries with lifting equipment, ensure that the lifting equipment has sufficient load capacity (the weight of the battery is indicated on the nameplate of the battery and the vehicle). The lifting

device must be pulled in a vertical direction to avoid damaging the battery box. The hook of the lifting device must be safe and reliable, and the hook must never fall on a single battery in the battery pack.

- Press the emergency stop switch and power key switch to the OFF position so that it is in the cut off position.
- Remove the connector of the battery cable.
- Connect the lifting device to the lifting hole.
- Lift the battery from the top and remove it with a transport device.



The installation process follows the reverse steps. It is worth noting that the position of the battery should be correct, and the connection is reliable. After reinstalling batteries, check the connections of all cables and connectors for obvious damage.

4.4 Battery Power display

Battery power display meter: The discharge of the battery is represented by 10 display bars with an increase of 10% per cell on the battery display meter.

As the battery's capacity is depleted, the shiny display will descend from the top down.

When the remaining power of the battery is in the following circumstances, the pre-designed "warning" mark will appear: Standard battery 30%, "warning" mark will appear, then the battery can be charged.

A pre-designed "warning" mark and a flashing "stop" mark will appear when the battery's remaining charge is below the following conditions: With a standard 20%, the "stop" mark will appear and remain lit. When the "Stop" sign is displayed, the lift function of the vehicle is automatically cut and locked.

Sufficient charge

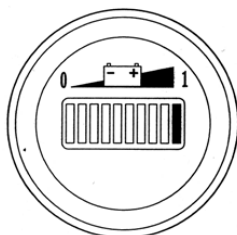

Need to charge

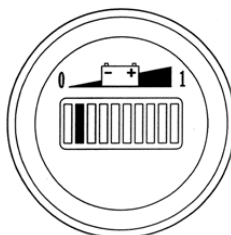

Low battery

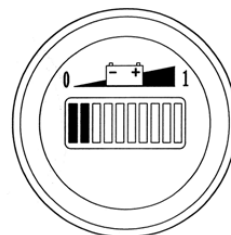

If the power display shows a lack of power shortly after lifting heavy objects, it can only be re-charged when the battery reaches at least 70%.

4.5 Charging

The QQA Series forklift truck is equipped with a dedicated charger for charging.



Please read the instructions carefully before charging.

Ensure good ventilation when charging the battery. Make sure that no metal objects are placed on the battery and check all cable and plug connections for obvious defects before starting the charging operation. All safety instructions such as battery replenishment regulations and battery charging preparations must be strictly followed.

4.5.1 Balanced charging

After the battery is used for a period, the voltage and electrolyte concentration of each battery will vary. By balancing the charge, this difference can be eliminated, thus keeping the performance of each battery consistent.

In the following cases, balanced charging is required: a single battery voltage is often lower than 1.7V; Large current occurs in the discharge process, such as running motor and lifting motor are used at the same time; Battery packs that are not charged in time after discharge: batteries that are over discharged and batteries that are not used for a long time.

Steps for balanced charging:

- a. Charge with 0.115A current.
- b. Charge until the voltage reaches 2.5V, when bubbles occur in the electrolyte, the current is halved (i.e. 0.0515A) to continue charging.
- c. Charge to the fully charged state stop for 0.5 hours and then half the current (i.e. 0.02515A) charge for one hour.
- d. Stop charging for 0.5 hours and charge with 0.02515A current for one hour.
- e. Repeat step D until there are bubbles in the battery when the charger is closed.



Normal use of the battery should be charged once a month

4.6 Specifications of batteries and chargers

Battery		Charger	
Rated voltage (V) : 24V	Rated capacity (Ah) : 210Ah	Input: AC115/230V 50/60Hz	Output: DC24V/30A
Rated voltage (V) : 24V	Rated capacity (Ah) : 280Ah	Input: AC115/230V 50/60Hz	Output: DC24V/40A

5. Maintenance and repair manual

The parts on the vehicle, especially the safety devices, shall not be modified without permission, and the speed of the vehicle shall not be allowed to change. All spare parts supplied by the original manufacturer are subject to strict quality inspection. To ensure the safety and reliability of the vehicle, please use original parts. Replacement parts, including all oil, must be collected and processed in accordance with local laws and regulations on environmental protection and health.

5.1 Safety regulations for repair and maintenance

Maintenance personnel: The repair and maintenance of this vehicle must be carried out by specialized personnel trained by the manufacturer. The manufacturer's after-sales service organization has specially appointed technicians outside, after the repair and maintenance is completed, the after-sales service engineer should sign on the maintenance record.

Vehicle lifting: When a vehicle needs to be raised for maintenance, the lifting device must be safe and reliable, and strictly tied to the position of the lifting point. When the vehicle is lifted, appropriate measures must be taken to prevent the vehicle from slipping or tipping over (wedges, wooden blocks may be used).

Cleaning operation: Do not use flammable liquid when cleaning the vehicle, before starting to clean, be sure to take safety measures to prevent the generation of electric sparks (for example: caused by short circuit). When cleaning steam cleaners or decreasing products, it is necessary to be very careful, because such cleaners will dilute the lubricated bearings, so it will lead to bearing damage and affect the service life. When operating a vehicle battery, disconnect the battery connector. Only clean electrical components or electronic devices with a weak suction or compressed air, non-conductive and anti-static brush and other tools.



If the vehicle is cleaned with water spray or a high-pressure cleaner, all electrical and electronic components must be carefully covered beforehand, as moisture can cause functional errors. Do not use steam nozzles for cleaning.

Operation of the electrical system: The operation of the electrical system of the vehicle is only allowed to be operated by personnel who have been professionally trained in this area. All measures to prevent electric shock must be in place before any electrical system operation is carried out. When operating a battery, disconnect the battery connector.

Traction motor and lifting motor are short time working system, driving motor: S2 60min, lifting motor: S3 15%.

Welding operation: To prevent damage to electrical components, these electrical components must be removed from the vehicle before any welding operation is performed.

Installation: When repairing or replacing hydraulic components, electrical and electronic components, they must be installed in the original position of the vehicle.

Wheels: The quality of wheels has a great impact on the stability and driving performance of the vehicle. Changes must be approved by the manufacturer. When replacing the wheels, you must ensure that the vehicle remains in the same horizontal state as when it left the factory (the wheels must be replaced in pairs, e.g., left and right together).

Roller: Without good lubrication, the roller will wear out quickly. It must be periodically lubricated according to the requirements of the following maintenance table, and the lubrication cycle should be shortened in harsh working environments (such as dust and high temperature).

Hydraulic tubing: If the hydraulic tubing damages, aging must be replaced.

5.2 Daily Maintenance (before each shift)

5.2.1 Check the battery electrolyte level.

- The liquid level will rise when charging.

5.2.2 Check each pole, cable, and protective cover of the battery.

5.2.3 Check whether the battery box is securely secured.

5.2.4 Check whether the vehicle has oil leakage.

5.2.5 Check the roller, fork, tubing and horn.

5.2.6 Check the brake condition.

5.2.7 Check the wear of the driving wheel and load wheel.

5.3 Professional maintenance manual



Comprehensive and professional maintenance is a very important work for the safe operation of vehicles. Failure to perform maintenance at the required intervals will result in vehicle failure and a potential threat to personnel and equipment.



The maintenance period shown in this manual refers to a single shift operation under normal working conditions. If it is used in a dusty environment, or the ambient temperature changes greatly or multi-shift operation, the maintenance period must be shortened.

Perform the operations listed in the following maintenance list and follow their respective cycles. The maintenance cycles are described as follows:

W1 = every 50 hours worked, but at least once a week.

M3 = every 500 hours worked, but at least once every 3 months.

M6 = every 1000 hours worked, but at least once every 6 months.

M12 = every 2000 hours worked, but at least once every 12 months.

During the test phase of the vehicle, the following additional operations must be completed:
(after the first 50 to 100 hours of work or 2 months:)

- Check that the nuts on the wheel are loose and tighten if necessary.
- Check hydraulic components for leakage and tighten if necessary.
- Replace the hydraulic filter.

Maintenance list

		Maintenance interval				
		Standard =●	W	M	M	M
		Cold storage = #	1	3	6	12
Chassis and frame	1.1	Check all load-bearing parts for damage		●		
	1.2	Check all bolt connections		●		
Driving part	2.1	Check drivetrain for noise and leakage		●		
	2.2	Check the fuel level of the transmission system		●		
	2.3	Oil change			#	●
Wheel part	3.1	Check for wear and damage		●		
	3.2	Check the bearings inside the wheel and make sure they fit tightly to the wheel a)		●		
Steering system	4.1	Check the steering motion		●		
Brake system	5.1	Check performance and conditioning	#	●		
	5.2	Check whether the reset function of the gas spring is appropriate, and whether there is leakage and damage		●		
	5.3	Check brake disc wear		●		
	5.4	Check brake connections and adjust if needed		●		
Lifting gear	6.1	Check performance, wear and conditioning		●		
	6.2	Visually check whether the load wheel is stuck		●		
	6.3	Check the fork tips and pallet racks for wear and damage	#	●		
Hydraulic system	7.1	Performance check	#	●		
	7.2	Check all connections for leakage and damage b)	#	●		
	7.3	Check the hydraulic cylinder for leakage and damage, and whether the accessories are safe and reliable	#	●		
	7.4	Check fuel	#	●		
	7.5	Replace hydraulic oil and filter d)			#	●
	7.6	Check that the pressure regulating valve is adjusted correctly			#	●
Electrical system	8.1	Performance check		●		
	8.2	Check that all cable connections are safe and reliable and that there is no damage		●		
	8.3	Check that the amperage of the fuse is appropriate				
	8.4	Check whether the switch and release CAM devices are safe, reliable and functional		●		
	8.5	Check connectors and replace worn parts if necessary				
	8.6	Check that the warning device is functioning correctly	#	●		
Motor	9.1	Check the wear of the carbon brush		●		
	9.2	Check the safety of motor attachments		●		
	9.3	Vacuum the motor frame and check the wear of the commutator		#	●	
Battery	10.1	Check the acid density, capacity, and battery voltage	#	●		
	10.2	Check terminal safety and grease suitability	#	●		
	10.3	Clean battery connectors and check for tightness	#	●		
	10.4	Check the battery cable for damage and replace it if necessary		●		
Lubricating oil	11.1	Grease the vehicle according to the lubricated schedule	#	●		
Comprehensive measurement	12.1	Check the grounding of the electrical system for errors				●
	12.2	Check travel speed and braking distance				●
	12.3	Check lifting and descending speed				●
	12.4	Check the safety device and closing device		●		
Demonstrate	13.1	Test run under rated load		●		
	13.2	After completing the above maintenance operations, the vehicle is proved to be reliable for personnel.	#	●		

- a. Check the tightness of the nuts on the wheel after about 100 hours of initial work and tighten them if necessary.
- b. Check the leakage at the joints of the hydraulic system after about 100 hours of initial work and tighten if necessary.
- c. After the first 500 hours of work.

5.4 Repair Manual

5.4.1 Fault Diagnosis

Old obstacle	cause	Dealing with the formula
Vehicle cannot move	<ul style="list-style-type: none"> - Battery connectors are not connected - The electric lock switch is in the 0 bit - The scam is not on - The battery is out of charge - The control handle is not in drive range F - The fuse is damaged 	<ul style="list-style-type: none"> - Check the battery connectors and connect if necessary - The electric lock switch is set to the "1" bit - Turn on the emergency stop switch - Check the charging status of the battery and recharge if necessary - Rotate control handle to drive range F - Check fuses FU01 and FU1
Goods cannot be lifted	<ul style="list-style-type: none"> - Vehicle is not running - Too little hydraulic fluid - The fuse is damaged - Battery charge is only 20/30% - Lifting microswitch contact is not good or damaged 	<ul style="list-style-type: none"> - Follow the procedures listed in the "Vehicle cannot Move" fault - Check the hydraulic fluid - Check fuses FU02 and FU2 - Battery charging. - Check the lift microswitch or replace it
Cargo cannot be lowered	<ul style="list-style-type: none"> - Oil dirty blockage control valve - Descent solenoid valve is not opened or damaged 	<ul style="list-style-type: none"> - Check the hydraulic oil and clean the control valve, and replace the hydraulic oil if necessary - Check the drop solenoid valve or replace it
You can't stop rising	<ul style="list-style-type: none"> - Lift microswitch damaged 	<ul style="list-style-type: none"> - Cut off the power supply and replace the lifting microswitch
Move in one direction	<ul style="list-style-type: none"> - The microswitch is not in good contact with the connecting cable 	<ul style="list-style-type: none"> - Check the microswitch in the control handle and the connection cable
Traffic moves slowly	<ul style="list-style-type: none"> - Battery power is insufficient, electromagnetic brakes are tight, or the corresponding cable contact is not good 	<ul style="list-style-type: none"> - Check battery indicator light, electromagnetic brake and corresponding cable
The car starts suddenly	<ul style="list-style-type: none"> - Controller damage - Control forward and backward knobs are not reset 	<ul style="list-style-type: none"> - Replace the controller. - Repair causes it to reset or replace



If the fault cannot be eliminated by some of the treatment methods listed above, please notify the manufacturer's after-sales service organization to be eliminated by specially trained maintenance personnel.

5.4.2 Preparatory work before repair

To prevent accidents that may occur during repair and maintenance operations, the following preparations must be completed:

- Park your vehicle safely.
- Press the emergency stop switch and remove the battery connector.



When the fork needs to be lifted or the vehicle lifted before maintenance operations can be carried out, measures must be taken to prevent the fork or vehicle from tipping over or slipping or falling suddenly. For the lifting of the vehicle, see the relevant section of "Transportation and Test" in the previous article.

5.4.3 Check the oil content of hydraulic oil

- Prepare the vehicle for repair and maintenance operations.
- Open the cover.
- Check the amount of hydraulic oil in the tank.
 - When checking the amount of hydraulic oil, the fork and frame must be reduced to the lowest position.

5.4.4 Preparatory work after maintenance and before use

- The vehicle can only be used again after the following operations have been completed.
- Clean the vehicle.
- Check whether the brake function is normal.
- Check whether the emergency stop switch works properly.
- Check whether the function of the horn is normal.

5.5 Storage of vehicles

If the vehicle is stored for more than 2 months, it must be parked in an antifreeze and dry place, and some necessary protective measures need to be taken before storage.

If the vehicle has been in storage for more than 6 months, discuss additional protective measures with the manufacturer's maintenance facility.



During storage, it is best to raise the vehicle overhead, ensuring that the wheels are completely off the ground to protect the wheels and the bearings within them.

5.5.1 Operations Performed Before Storage

- Clean the vehicle thoroughly.
- Check whether the brake function is normal.
- Check the oil level of the hydraulic oil and fill up if needed.
- Apply lubricating oil or grease to protect all components.
- Lubricate the vehicle against a detailed lubrication periodic table.
- Recharge the battery.
- Disconnect and clean the battery and apply electrode grease to the battery electrodes.

In addition to this, the battery must also comply with some special requirements in the battery manual to protect the battery.

5.5.2 Measures taken during storage



Battery operation

It is very important to charge the battery regularly and charge the battery every 1 month. Otherwise, due to the self-discharge of the battery, all the electricity will be lost, and the battery will be completely scrapped.

5.5.3 Retest

- Clean the vehicle thoroughly.
- Add lubricating grease to the vehicle against the lubrication periodic table.
- Clean the battery, apply electrode grease to the electrode bolts, and then connect the connector.
- Recharge the battery.
- Check whether the gearbox oil of the drive wheel contains water, if so, the gearbox oil needs to be replaced.
- Check whether the hydraulic oil contains water, if so, you need to replace the hydraulic oil.
- Start the vehicle.
 - If the switches of the electrical system fail to make poor contact, spray all exposed electrical connections with contact cleaner and remove the oxide layer from these connections by repeated operation.



Several electromagnetic brake tests are conducted immediately after the retest.

5.5.4 Oils and lubricants

Lubricate the periodic table

Filling point	Lubrication cycle			
	500 h	1000 h	2000h	
Wheel bearing	L			A
Rail post	L			B
roller	L			C
Hydraulic system	C		O	D
Slewing bearing		L		E
Gear case	C		O	F

L=oilng C=Check O=Change

Instructions for oils and greases

Type of lubricant		Lubricant name		Lubrication zone
		>-15°C	<-15°C	
A	grease	2# fat butter	2# fat butter	Bearings, bushings, joints
B	grease	2# fat butter	2# fat butter	Steel channel
C	grease	2# fat butter	2# fat butter	roller
D	Hydraulic oil	32# hydraulic oil	32# hydraulic oil	Hydraulic system
E	grease	2# fat butter	2# fat butter	Slewing support bearing
F	Gear oil	W85-90 gear oil	W85-90 gear oil	Gear case

6. Electrical and hydraulic schematics

- Hydraulic schematic diagram

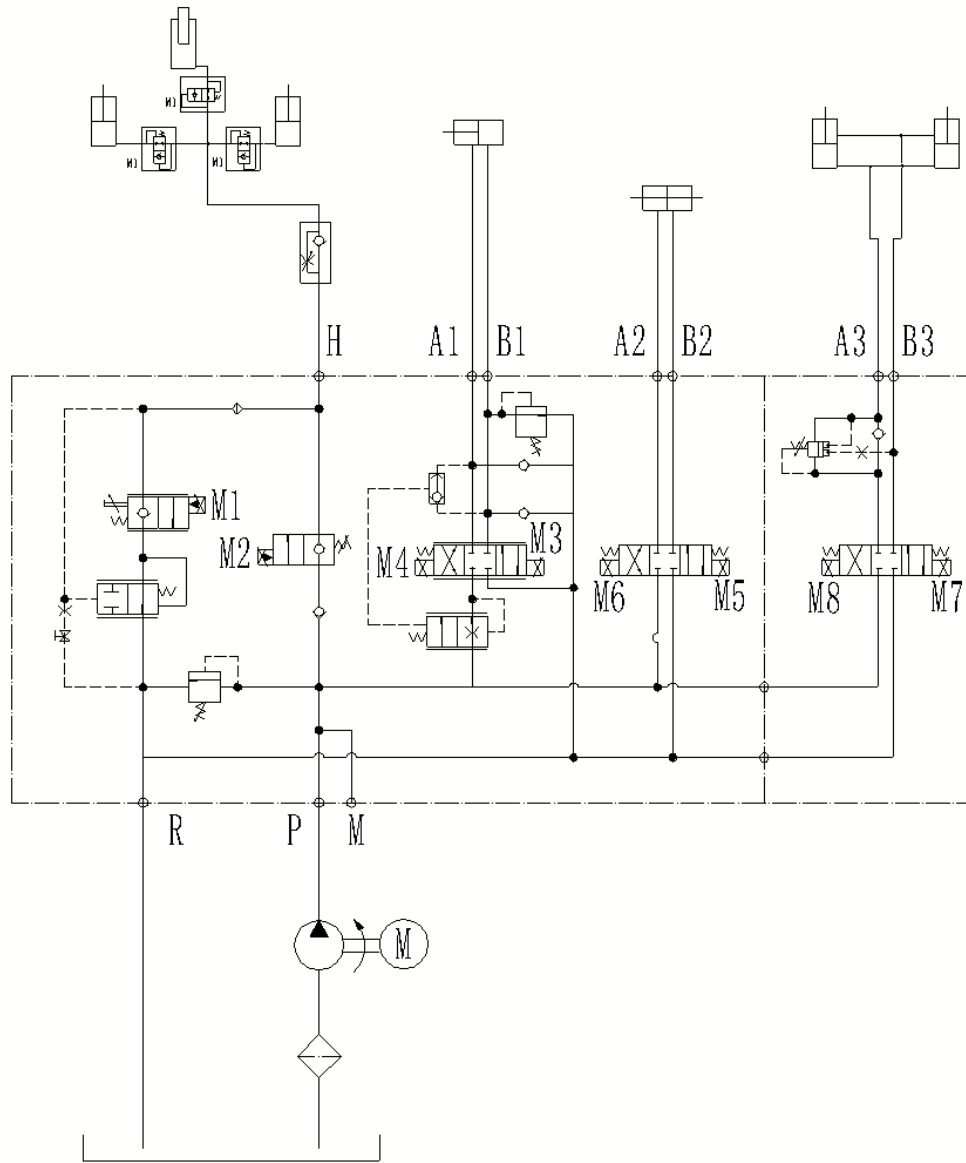

H: lifting and descending A1/B1 move forward and backward

A2/B2 move sideways A3/B3 tilt forward and backward

Electrical schematic diagram

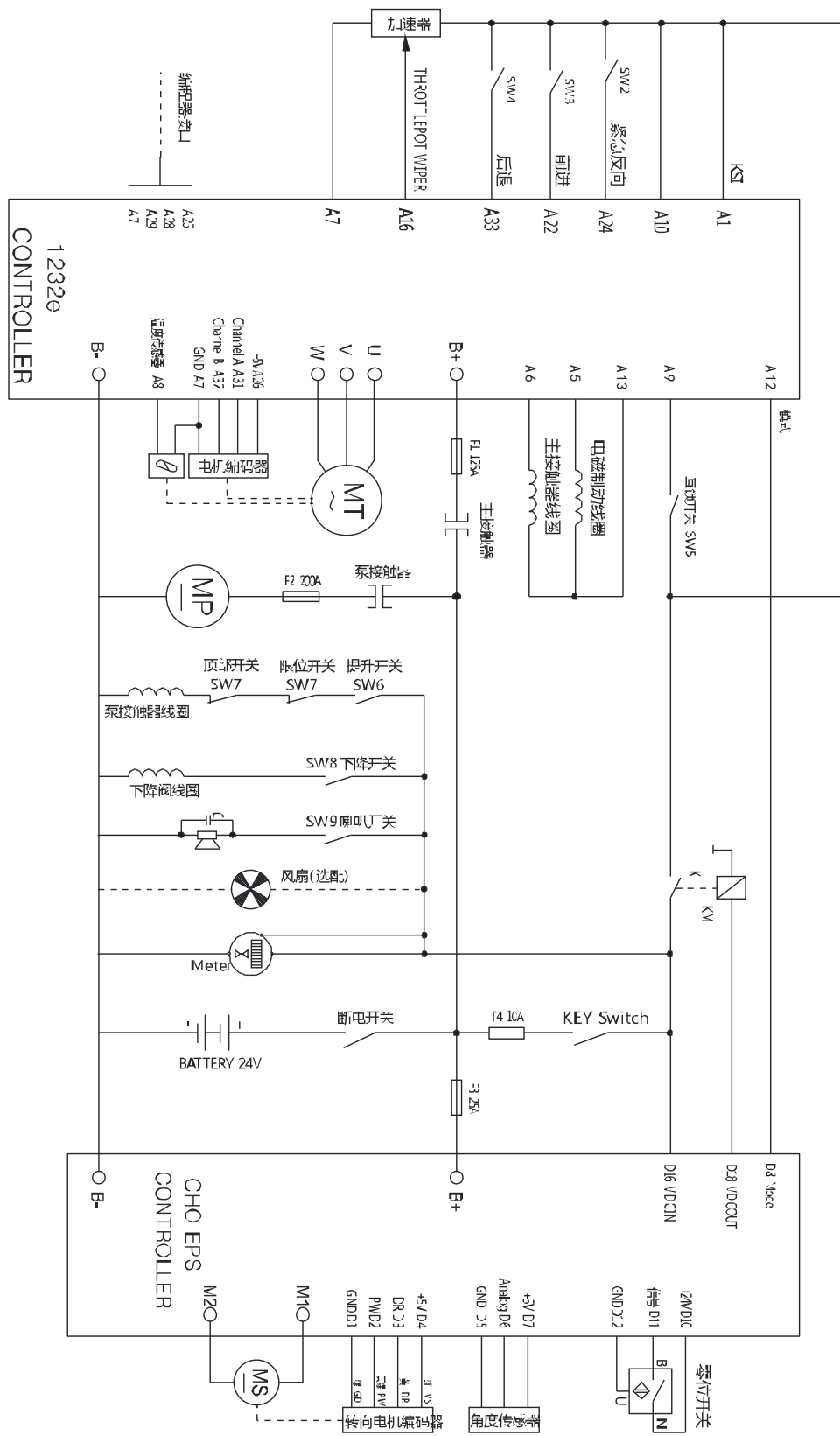

CURTIS