



Operations & Maintenance Manual

Fork Over Stacker

EB13CD



01. Instructions for use

Please read this manual carefully and operate the vehicle safety.

- Do not operate this vehicle without training.
- Please comply with ISO3691 “Safety Specification for Motor Vehicles Industry”.
- Please do not modify or change the repair parameters, including adjusting the pressure. Any loss or damage to the vehicle resulting from such actions will be your responsibility, and doing so will void our warranty commitment.

SPECIAL WARNING:

The company is committed to innovation and sustainable development. As part of this commitment, we continually improve the technology of our products. Therefore, we reserve the right to make changes and improvements to any product described in this specification without prior notice.

02. Main technical parameters

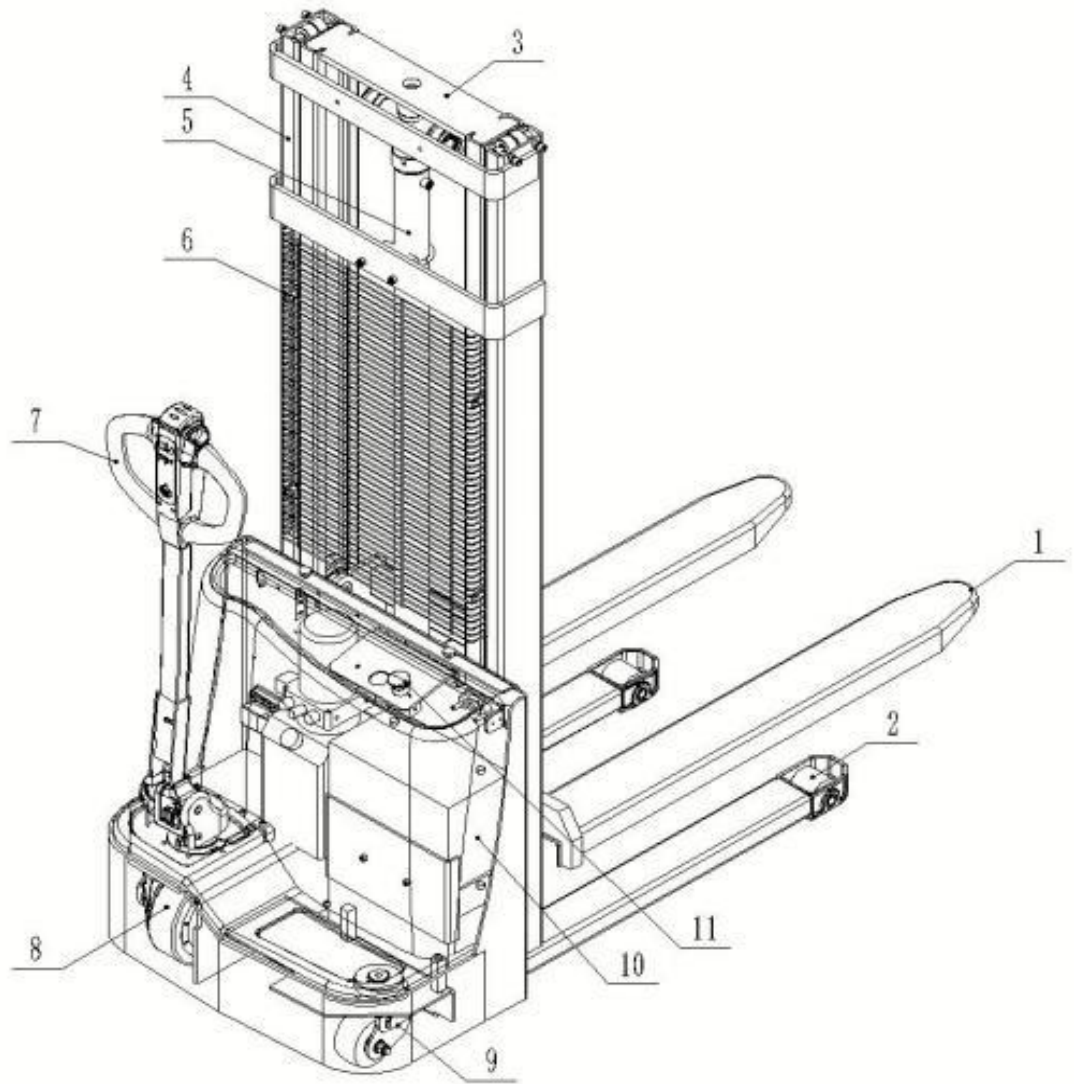

Item no.	Description	Item no.	Description
1	Fork	7	Handle
2	Loading wheel	8	Drive wheel
3	Inner mast	9	Balance wheel
4	Outer mast	10	Battery
5	Oil pump	11	Emergency button
6	Protect mesh		

03. External drawing

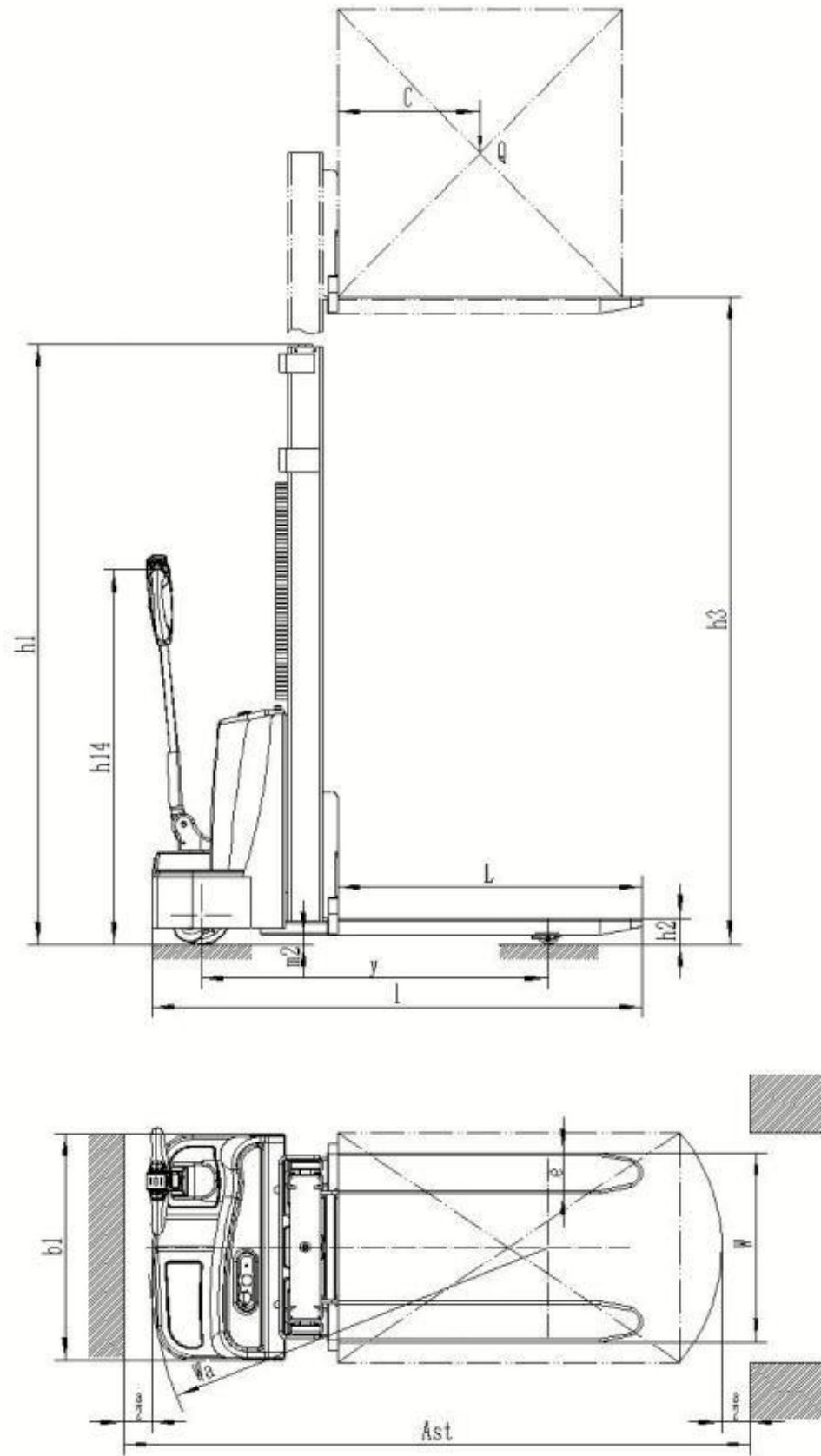

1.1	Model		EB13CD	
1.2	Drive type		Battery	
1.3	Operation type		Walkie	
1.4	Rated capacity	Q(lbs.)	2800	
1.5	Load center	c(in)	20	
2.1	Service weight	lbs.	992	
3.1	Wheels material		PU	
4.1	Max. lift height	h3(in)	118	
4.2	Lowered mast height	h1(in)	82.2	
4.3	Extended mast height	h4(in)	139.4	
4.2	Lowered fork height	h13(in)	3.54	
4.3	Overall length	l1(in)	67.7	
4.4	Overall width	b1(in)	31.1	
4.5	Fork size	S/e/l(in)	2.36/5.6/42.1	
4.6	Fork width	b5(in)	21.6/26	
4.7	Ground clearance	m2(in)	0.98	
4.8	Turning radius	Wa(in)	55.3	
5.1	Traveling speed, laden/unload	mph	2.2/2.5	
5.2	Lifting speed, laden/unload	in/s	3.34/4.33	
5.4	Max. gradient, laden/unload	%	3/10	
5.5	Brake		Electromagnetic brake	
6.1	Drive motor power	kW	0.75	
6.2	Lift motor power	kW	2.2	
6.3	Battery voltage/rated capacity	V/Ah	2×12/65	2×12/85
6.4	Battery weight	kg	17.5×2	23×2
7.1	Noise level at the driver's ear meets DIN12053	dB(A)	<70	

Table 1

04. Operation Guide

The correct use and operation of the vehicle will bring great convenience to your work. Incorrect operation or improper use of the vehicle may result in damage to the vehicle, as well as posing a risk to your personal safety and cargo.

Before use, please ensure the vehicle is in normal working condition by checking the following: whether the hydraulic pipeline is leaking oil, whether the wheels of each group can be intact and normal, and whether there is a stuck phenomenon. It is strictly prohibited to use faulty vehicles.

Handle accelerator function

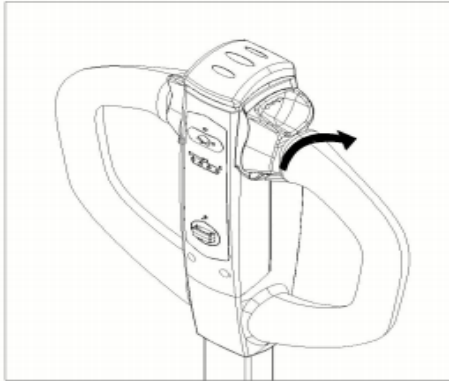

MOVE FORWARD

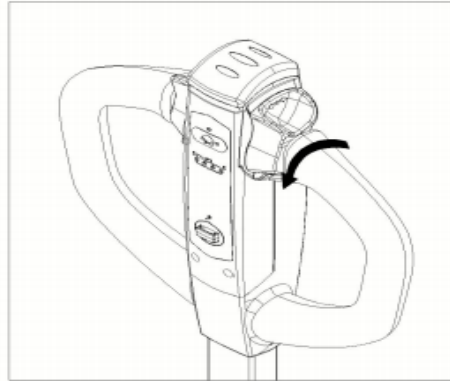

MOVE FORWARD

Forward driving and reverse driving

The flower-shaped turning button located above and left of the rudder handle is used for running speed control, which can be operated with the left hand or right-hand finger or at the same time.

Push the speed button forward, the vehicle moves forward, the speed is proportional to the Angle, release the finger, the speed button will return to 0 position, the vehicle will gently stop.

Push the speed button down and back, the vehicle moves backward, the speed is proportional to the Angle, release the finger, the speed button will return to 0 position, the vehicle will gently stop.

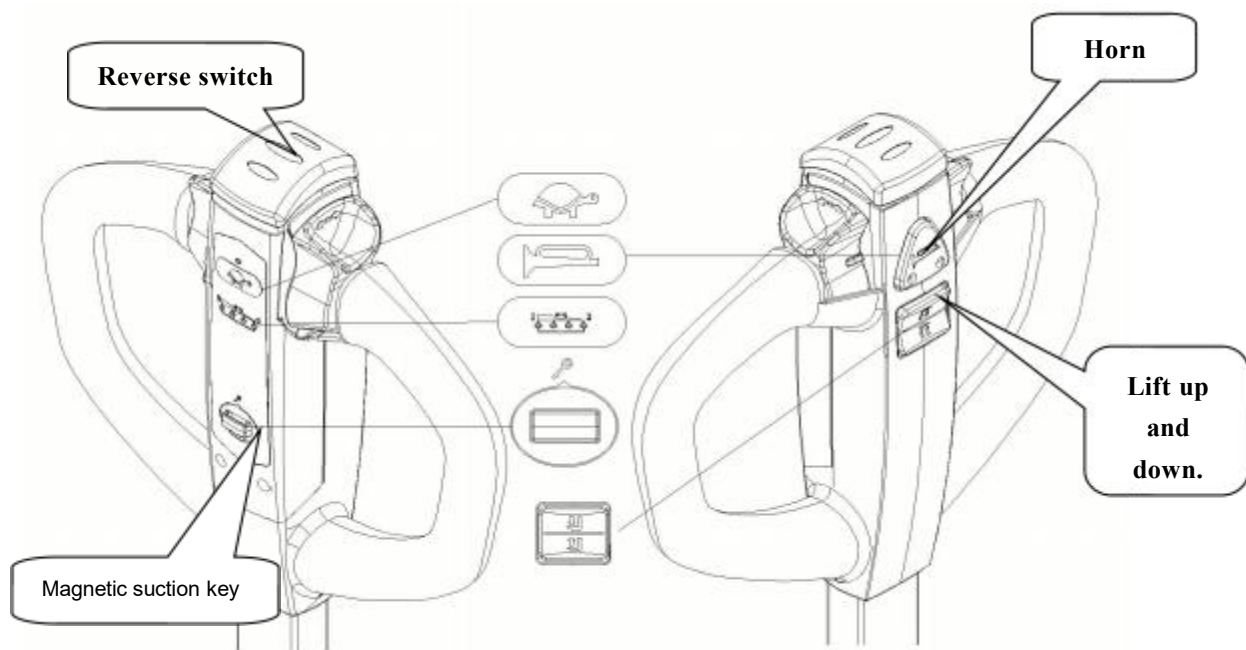

The red button at the top of the accelerator is an emergency reverse switch. When this switch is touched, the vehicle will reverse the reverse motion.

Up, down switch and horn button

The lift button is located on the right side above the rudder handle. Press this switch to make the fork move upward.

The drop button is located on the left side above the rudder handle. Press this switch to make the fork drop.

The horn button is located in the middle above the rudder handle. Press this switch to sound the horn.

Magnetic key: Put the magnetic key into the tiller hole, and the car will be connected to the general power supply of the vehicle. Pull out the magnetic key and cut off the power supply.

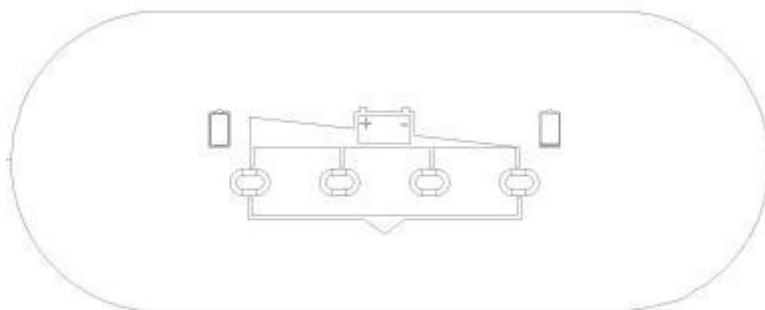

Electricity meter, only after the power switch and magnetic key are turned on, the unit will show the power storage status, it is displayed by four indicator lights.

- a. When the indicator of the meter is displayed on the left, it indicates that the power supply is sufficient for normal us.
- b. When the indicator light is displayed in the middle, it means that there is still a small amount of power, please pay attention to charging.
- c. When the indicator light shows on the right side, it means that the power supply is insufficient, please charge immediately!

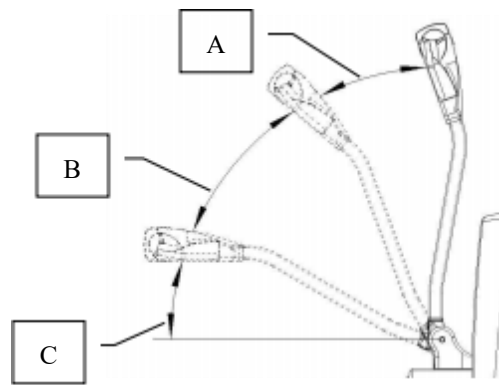

Running and braking

The rudder handle is divided into three sections A, B and C in the vertical plane, and the two zones A and C are the braking zones.

When the rudder handle is located in zone A or zone C, the vehicle is in the braking state. If the rudder handle is located in area B, the vehicle is in normal running condition.

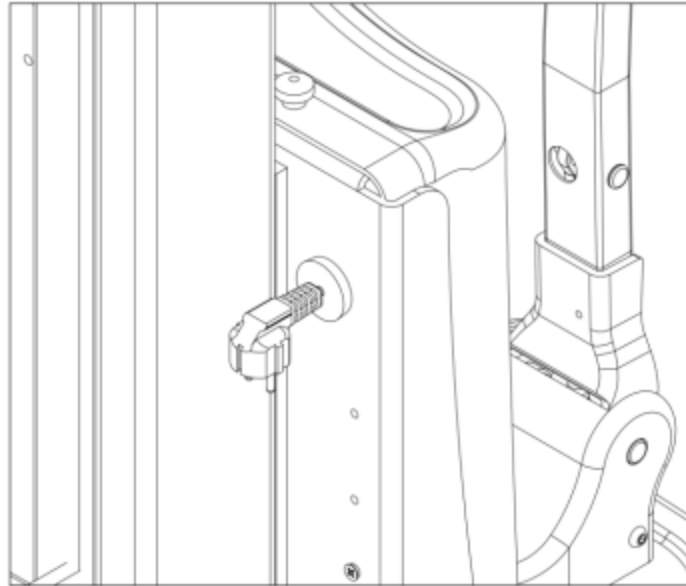

Charging jack

The charging port is located in the throat of the vehicle, as shown in Figure 2-6, and the charging port is related to the charger placed on the vehicle:

- a. Built-in charger, the vehicle comes with its own charger, the charging port is a three-core socket, and the power cord can be connected to any conventional wall outlet.
- b. External charger, there is no charger in the vehicle, the charging port is a two-core socket, and an external charger is required for charging. The charging port should be connected with the appropriate plug-in of the external charger

05. Warning logo and name plate explanation

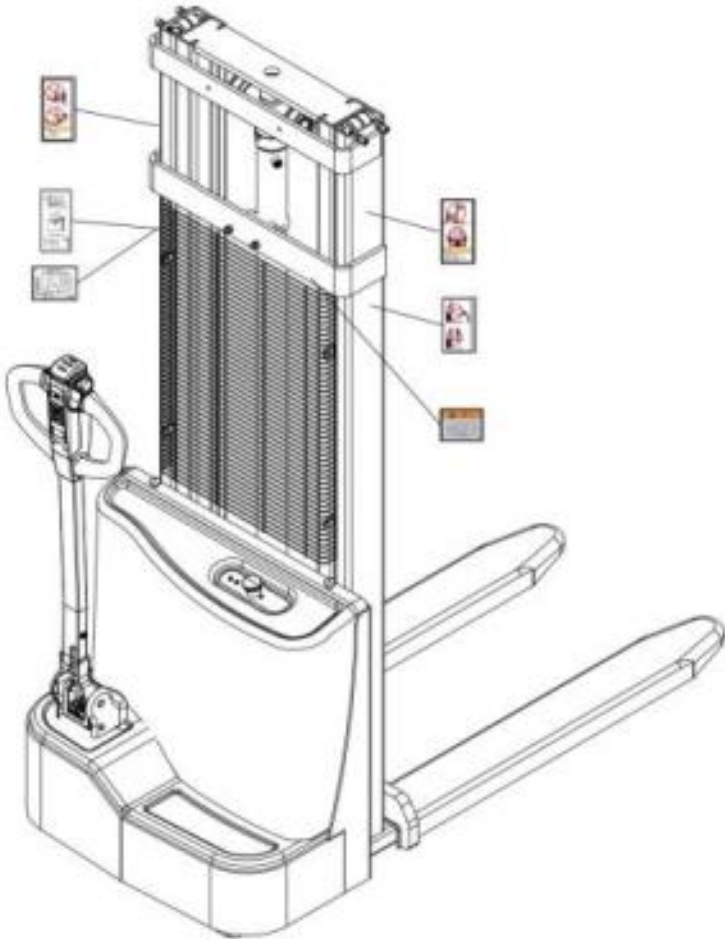

Figure 2-1

⚠ Load curve: Please strictly follow the load curve nameplate use, do not overload use.

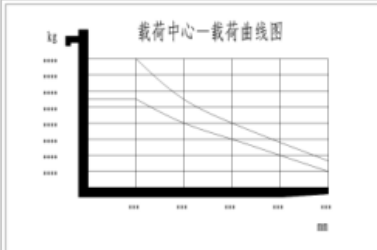

Figure 3-1

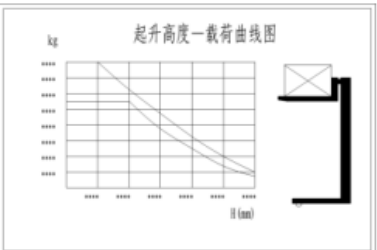

Figure 3-2

Nameplate:

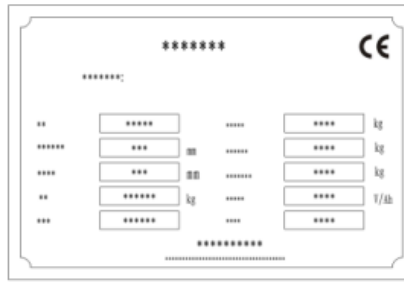

Figure 4-1

Trademark	maker	CE
Model number		Rated load weight
Maximum lifting height	mm	Battery free weight
Load center	mm	Allowable battery weight
Be self-possessed	Kg	Voltage/capacitance
Serial number		Production date

Warning sign:



Figure5-1



Figure5-2



Figure5-3



Figure5-4



Figure5-5

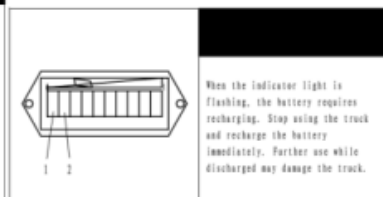

Figure5-6

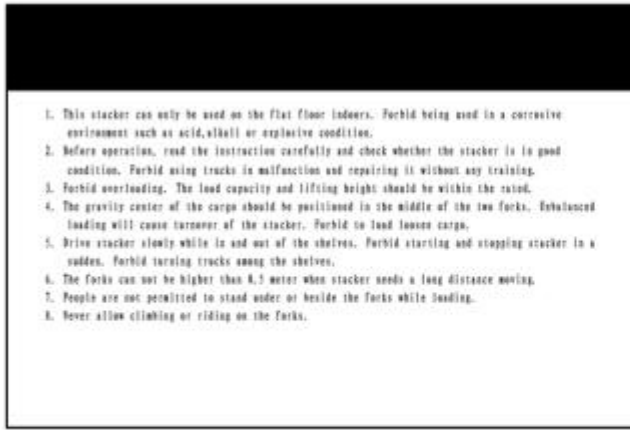

Figure5-7



Figure5-8

Figure5-1 Do not stand in dangerous areas under the forks

Figure5-2 No one is allowed to stand on the forks

Figure5-3 Hoisting holes

Figure5-4 Avoid all movable parts. Movable parts can cut or squeeze hands, feet, arms, or legs.

Figure 5-5 Charging flag

Figure5-6 Indicator of the meter

Figure5-7 Forklift operation

Figure5-8 Stacking bulk cargo is strictly prohibited

06. Battery operating environment



Please use the battery at 14°F ~ 113°F



Avoid filling, drinking and corrosive liquids



Keep batteries away from heat sources, open flames, flammable and explosive gases (liquids)



Keep metal objects away from the battery box

If the battery has odor, heat, deformation, etc., please stop using it and stay away from the battery immediately, and call the official customer service phone to make an appointment for maintenance.

Battery charging environment



Please charge the BBA battery at the ambient temperature of 32°F ~ 95°F



Charging time should not exceed 12 hours, avoid overcharging affecting the life of the battery

Tip:

1. If the battery is faulty, please call the official customer service to make an appointment for maintenance. If you remove the battery without permission, it may cause the battery to leak, heat, smoke, and seriously lead to fire or explosion.
2. When the ambient temperature is lower than 32°F, the charging system will be turned off in order to protect the battery, please charge the battery in the environment above 32°F.
3. The use of non-original charger may lead to battery leakage, heat, smoke, serious and may lead to fire and/or explosion.
4. If your battery charges for more than 12 hours and is still not full, please stop charging and call the official customer service line to make an appointment for maintenance, we will have a designated person for you to make an appointment for maintenance.
5. In order to ensure battery life and excellent performance, please recycle between 20% and 90% of the power as far as possible. When starting normally, please operate the accelerator knob slowly.
6. Do not place the battery in an environment of 104°F to avoid irreversible capacity attenuation of the battery, affecting your normal use.
7. Due to the special properties of lithium batteries, the battery capacity at low temperature will have different degrees of attenuation, specific reference: 14°F available capacity is 70%, 32°F is 80%, 77°F is 100%.
8. If you want to store your battery for a long time, please keep the battery at 50%, keep the ambient temperature at 32°F ~ 68°F, and complete the battery charging and

discharging at least once a month. If the power is less than 20% or more than 90% for a long time, it will lead to irreversible power attenuation of the battery in the future.

9. Please avoid storing the battery in places at risk of falling, so as to avoid falling resulting in battery leakage, heat, and serious fire or explosion

07. Troubleshooting

No.	Fault	Reason	Solution
1	Switch on the power, the power meter no display	The electrical box panel 10A fuse blown or damage of the power switch.	Replace fuse or power switch
2	Can not reach max. lift height	Lack of Hydraulic oil	Add hydraulic oil
3	Hydraulic pump station motor work with noise, pallet fork can not rise or fall.	Electromagnetic valve of the hydraulic pump with dirt jam or stuck.	Remove the valve core, clean with gasoline or kerosene.
4	After open the power switch, with display on power meter, but forks can not lift.	Ascension circuit 175A fuse blown or battery protection controller is damaged.	Replacing the fuse or battery protection controller. Such as broken again, should check whether the circuit is short circuit or device damage.
5	Oil leaking	Sealing / washer damage or failure, nipple joint is loose	Replace with the new seal and tighten joint

Table 2

08. Maintenance/repair

In order to make your vehicle last longer, we recommend that you check and maintain your vehicle regularly, and if your vehicle is out of use for a long time, please also complete checks on a regular basis. When not in use please charge the battery at least every 30 days to keep the life of the battery in good condition.

Periodic maintenance inspection

We recommend that you do your first maintenance for one month after purchasing your vehicle, followed by regular maintenance checks every six months.

Daily maintenance check

If you find anomalies during the inspection and maintenance process, please call the official customer service hotline to make an appointment with the authorized service center of the forklift truck for inspection.

Vehicle storage method:

1. please store the vehicle in a flat, stable, well-ventilated, dry location.
2. please avoid the vehicle sun and rain, to prevent parts damage or aging.
3. please scrub the body with tap water and neutral detergent.
4. if you store the vehicle for a long time, please refer to the "battery instructions" section, after long-term storage, please fully charge the battery before use.

Regular maintenance check items:

Maintenance item	Maintenance Purpose
Brake	Check brake performance to prevent work-related accidents during handling
Wheel	Detect wheel damage to prevent heavy lifting or excessive power consumption during use
Electric door lock, battery lock	Detect electric locks and battery locks to prevent inflexibility or occasional failure
Drive wheel, oil pump	Detect the driving wheel and oil pump lift, to prevent the vehicle can not be stacked to transport goods
Line	Detect whether the line connector is loose or the knot is broken to prevent the line failure
Screw	Check whether the screws in the key part are firm and prevent loosening and falling off
Battery	Detect battery appearance and cell performance to prevent line failure and extend service life
Recharger	Check whether the charger cable is broken, broken, disconnected, and whether the input and output connectors are intact and reliable
Oiling	Check whether the bearing needs to be lubricated
Clean	Clean the surface with dust removal

Warm reminder

1. When you receive the vehicle, please check the car on the spot.

2. If you need to repair or replace the electric vehicle and its parts in the process of using the vehicle, please keep the corresponding after-sales service card after repair or replacement.

Warranty policy

1. We will provide you with 12 months of vehicle core components warranty (core components including accelerator, controller, frame), gear box, motor, cylinder warranty for half a year, other parts warranty.
2. During the warranty period, parts will be provided for repair.
3. The warranty service period of the sold products is calculated from the date of shipment.

Non-warranty policy

The following conditions do not belong to the scope of warranty service.

1. According to the "forklift parts three guarantees standard" as the basis, exceed the specified service period and scope.
2. Failure and damage to the products caused by the correct use, handling, stacking and maintenance of the storage forklift products according to the instructions.
3. Damage or natural damage caused by rain, ice and snow soaking, smoking, drugs, chemical corrosion, etc., is not covered by the warranty, and failure or damage caused by force majeure (including but not limited to earthquake, typhoon, fire, flood, social events, group events, violent crimes, etc.).
4. Not in the storage forklift authorized service center for maintenance, modification, decomposition, maintenance of the machine damaged the overall product and parts of the normal use of the state.
5. The use of non-original parts caused by the storage forklift parts damage or unauthorized change of the circuit, line, hydraulic configuration.
6. Product failure or damage caused by human factors such as crash, fall, overload, and manned during use.
7. Improper loading of goods, heavy objects quickly loaded on the fork; The center of gravity of the goods is not in the two cargo forks, stacking bulk cargo.
8. The goods are placed on the car body for a long time, resulting in the deformation of the frame and other failures.
9. There is no valid three-package voucher, after-sales service card or purchase product invoice, voucher or card number does not match the product.
10. Unauthorized alteration, change the storage forklift products and parts of the three guarantee service date.
11. Not the quality of the product itself, such as the purchase of the product after the color, shape, appearance, etc.
12. The vehicle and the main parts of the warranty and anti-counterfeiting label damage.

9. Hydraulic schematic diagram

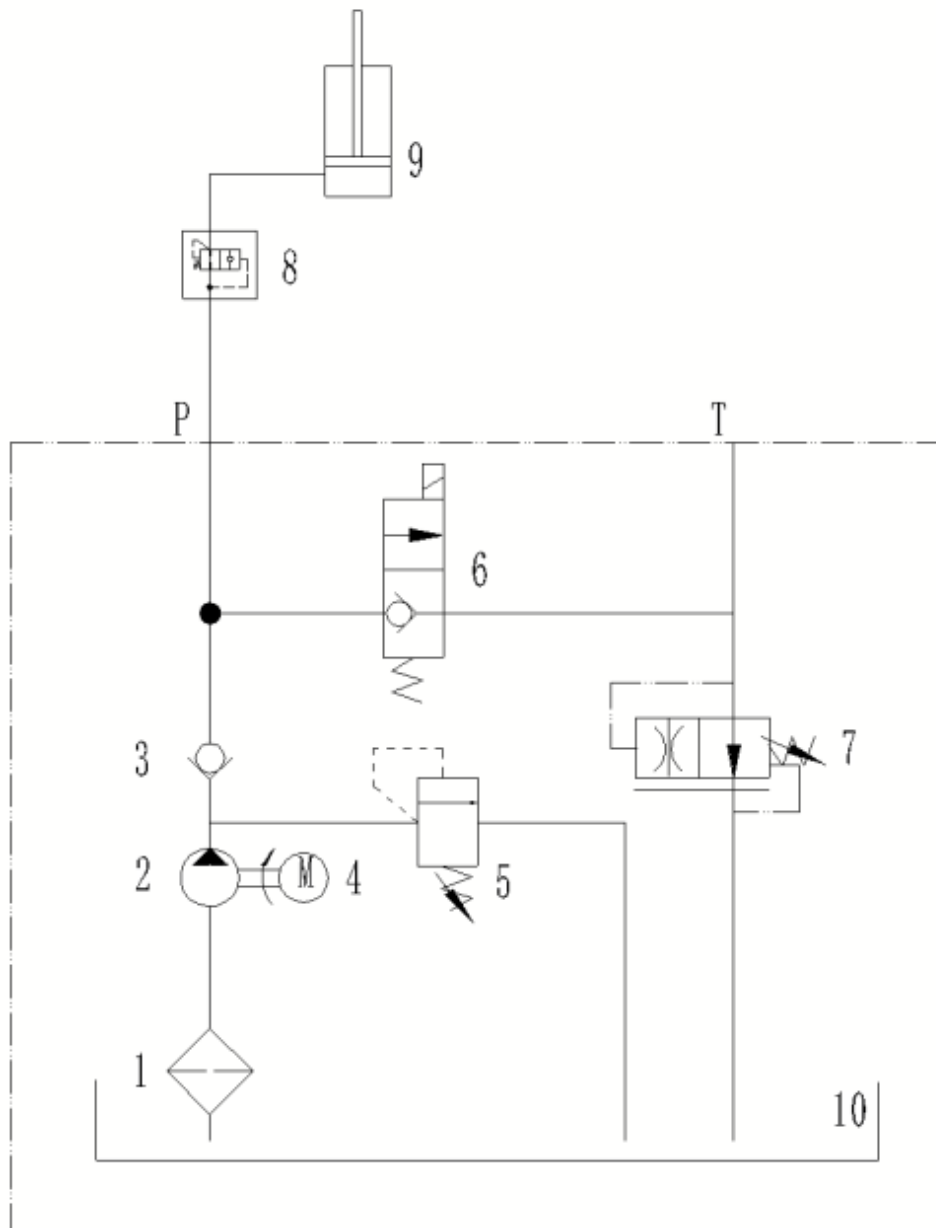

- 1 Oil filter 2 gear oil pump 3 Check valve 4 DC motor 5 relief valve
6 Electromagnetic reversing valve 7 Built-in balance valve 8 explosion-proof valve

10. Electrical schematic diagram

