

EKKO

MATERIAL HANDLING EQUIPMENT

MOVING AHEAD

4-WHEEL ELECTRIC FORKLIFT LITHIUM SERIES

**EK20G-LI / EK25G-LI / EK25G-212LI /
EK30G-LI / EK35G-LI**

- Load Capacity 4000-7000 lbs.
- Lift Height 189-212 in.
- **Side Shift**
- Free Lift
- Hydraulic Steering
- ZAPI Controller
- Tilt
- Fork Length 42"
- Li-Iron Battery
- 3-Phase 480V Charger
(Optional 220V & 110V)
- 3 Year Limited Warranty



EK20G-LI / EK25G-LI / EK25G-212LI / EK30G-LI / EK35G-LI LITHIUM POWERED FORKLIFT

Superior quality, maneuverable, compact, and durable for all your material handling applications. Ideal for small aisles and areas.

WEIGHT CAPACITY: 4000-7000 lbs. @ 20" load center

LIFT HEIGHT: 189-212"

FORKS: 42"

MAST HEIGHT: 83-94.5"

TURNING RADIUS: 84.2"-87.9"

FREE LIFT: 40.94"-54.9"

SIDE SHIFT – 3 Way Valve

BATTERY & CHARGER: 80V/150-250Ah Lithium Battery with 2 hour fast charge. 3-Phase 480V Charger, (optional 220V & 110V)

SPEED TRAVEL: Unloaded 9.3 MPH/Loaded 9MPH

LIFTING SPEED: 17.3 ips empty; 11.4-12.5 ips loaded

LOWERING SPEED: 14.1-15.7 ips empty; 15.7-18.1 ips loaded

WHEELS: Solid Pneumatic

ZAPI Controller

AC Drive Motor:

BRAKES: Drum Brakes with Electro-magnetic braking for secure stopping power; Electronic neutral braking for accurate control.

LIGHTING: LED Head lights, rear lights Brake lights, strobe light and backup alarm.

OPERATOR CONTROLS: EPS (Electric Power Steering), tilt lifting, lowering, side shifting forks, horn functions are located in the ergonomic sit down; Led lighting. Battery Discharge indicator and travel speed Odometer

CHASSIS AND MAST: Robotic Welding; Heavy duty steel chassis with I-beam mast for durability; Telescoping mast.



4-Wheel Lithium Forklift

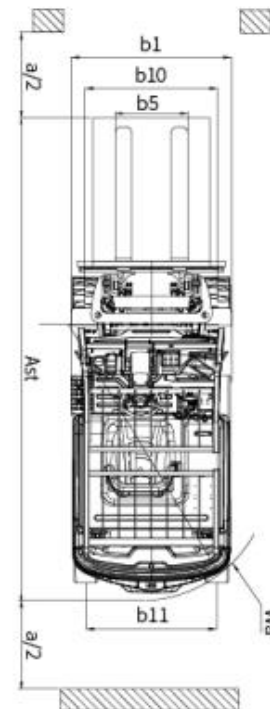
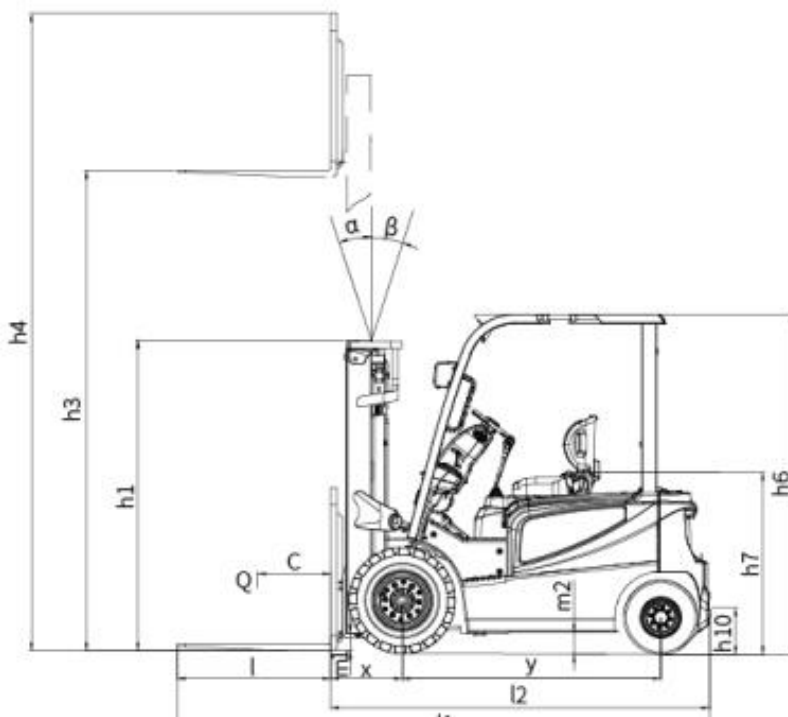
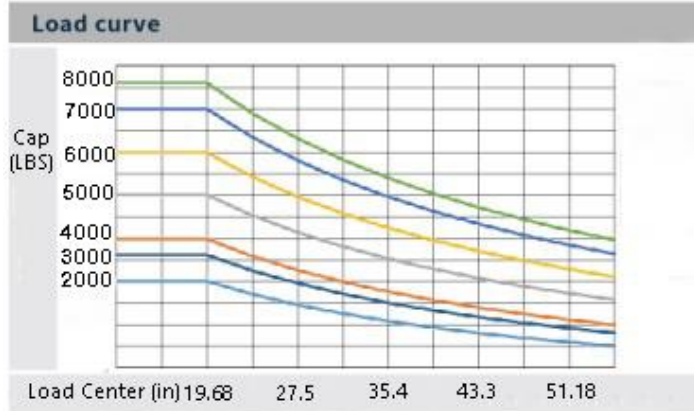

MODEL #	CAPACITY	LIFT HEIGHT	FREE LIFT	BATTERY	SERVICE WEIGHT
EK18G-LI	4000 LBS.	189"	47.8"	80V/150AH	9,200 LBS.
EK18G-212LI	4000 LBS	212"	54.9"	80V/150AH	9,330 LBS.
EK20G-LI	4500 LBS.	189"	47.48"	80V/202AH	9,032 LBS.
EK25G-LI	5000 LBS.	189"	47.48"	80V/202AH	9,782 LBS.
EK25G-212LI	5000 LBS.	212"	54.9"	80V/202AH	9,915 LBS.
EK30G-Li	6000 LBS.	189"	40.9"	80V/250AH	10,596 LBS.
EK35G-Li	7000 LBS.	189"	40.9"	80V/250AH	11,208 LBS.