

# Full Powered Fork Over Stacker EB13CD

- 2800 lbs. load capacity
- Lift height 118"
- Lowered Mast Height 82.3"
- Polyurethane Tires
- Batteries 2x12V/85Ah
- Charger Included
- DC Drive Motor
- Fixed Forks



EB13CD		
Power		Electric
Operation Type		Walk-behind
Rated Lifting Weight / Rated Load	Q (lbs.)	2800
Load Center Distance	c (in)	24
Wheelbase	y (in)	46.3
Service Weight (including battery)	lbs.	992
Tire Type, Drive Wheel / Load Wheel		Polyurethane Tires
Drive Wheel Size (Diameter x Width)	in	Φ8.27 x 2.76
Load Wheel Size (Diameter x Width)	in	Φ3.15 x 2.76
Track Width, Drive Wheel	b11 (in)	19.8
Height When Mast is Retracted	h1 (in)	82.3
Lift Height	h3 (in)	118
Maximum Height When Mast is Extended	h4 (in)	147.6
Minimum Fork Height	h13 (in)	3.54
Overall Length	l1 (in)	71.7
Fork Dimensions	s/e/l (in)	2.36x5.59x45.28
Minimum Ground Clearance at Wheelbase Center	m2 (in)	1.18
Minimum Turning Radius	Wa (in)	55.1
Operating Speed, Full Load/No Load	mph	2.5/2.5
Lifting Speed, Full Load/No Load	in/s	3.54/5.12
Maximum Gradient, Full Load/No Load	%	10-Mar
Drive Motor Power	kw	0.75
Lift Motor Power	kw	2.2
Battery, Maximum Capacity/Minimum Capacity	V/Ah	2*12V/85Ah
Drive Control Type		DC
Steering Type		Mechanical

**Skids, bins and pallets without bottom boards are all loads that can be lifted by a fork over stacker**



**Pallet without bottom boards**



**4-Way Plastic Pallet**



**Skid**

# Fork Over Stacker

EB13CD

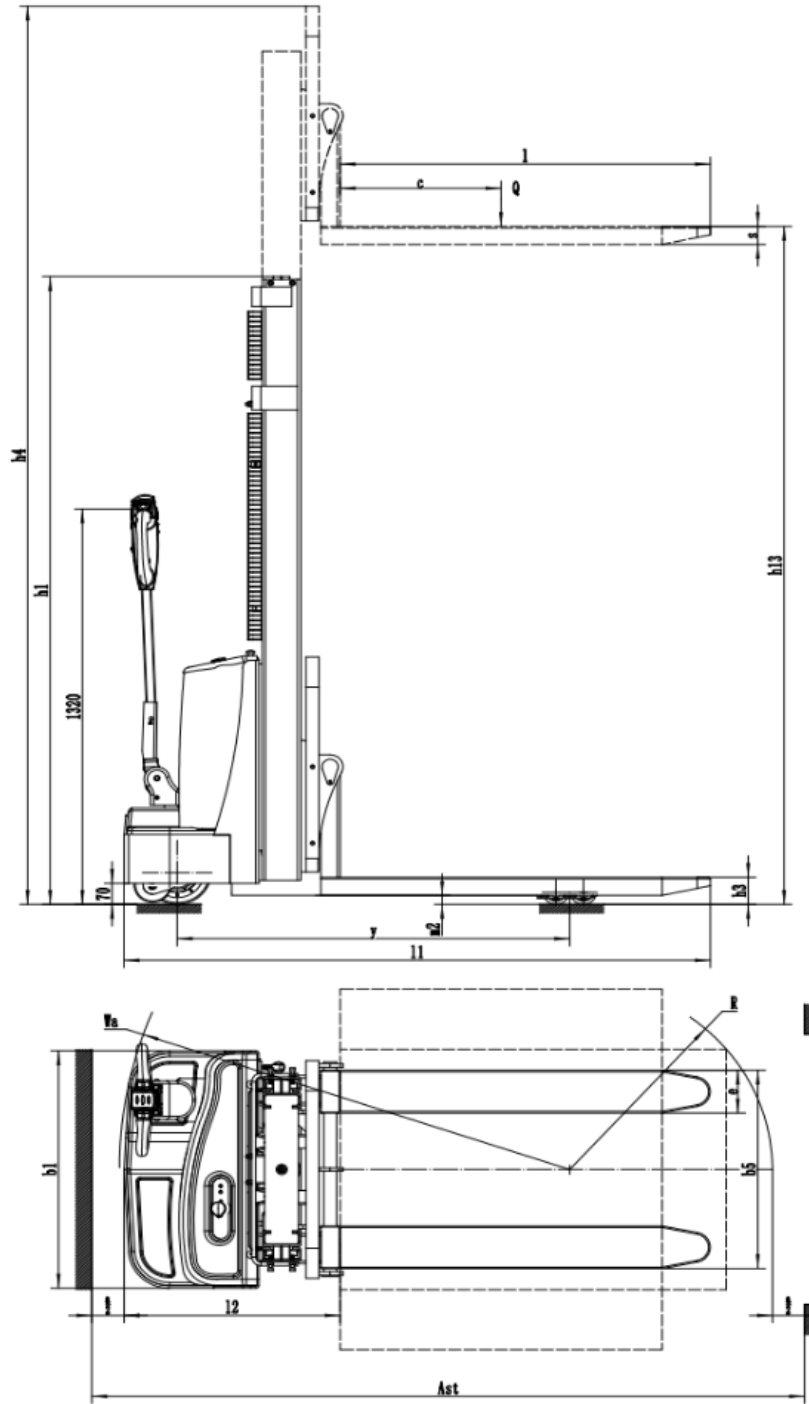

MODEL #	MAST	LIFT HEIGHT	MAX MAST HEIGHT	SERVICE WEIGHT
EB13CD	82.3"	118"	147.6"	992 Lbs.



1761 W. Holt Ave.  
Pomona, CA 91768 USA

AUTHORIZED DEALERS ONLY  
[www.ekkolifts.com](http://www.ekkolifts.com)

T: (877) 232-6517 F: (909) 222-6861